

# Index

	Page #
Introduction -----	2
Executive Summary-----	5
Kenai Peninsula Borough	
Sales - KPB Finance Department-----	13
Construction – City administrations throughout KPB -----	31
Employment St of AK, Dept of Labor -----	47
Population – U.S. Census Bureau -----	52
Homer	
Sales - KPB Finance Department-----	59
Construction – City of Homer -----	67
Homer Population -----	73
Cost of Food – University of Alaska Fairbanks Cooperative Extension -----	74
Kenai	
Sales - KPB Finance Department-----	77
Construction – City of Kenai-----	85
Kenai Population -----	91
Cost of Food – University of Alaska Fairbanks Cooperative Extension -----	92
Seldovia	
Sales - KPB Finance Department-----	95
Construction – City of Seldovia -----	103
Seldovia Population -----	107
Seward	
Sales - KPB Finance Department-----	109
Construction – City of Seward-----	117
Seward Population-----	123
Cost of Food – University of Alaska Fairbanks Cooperative Extension -----	124
Soldotna	
Sales - KPB Finance Department-----	127
Construction – City of Soldotna -----	135
Soldotna Population-- -----	141
Cost of Food – University of Alaska Fairbanks Cooperative Extension -----	142
Other	
Sales – KPB Finance Department -----	145
Directory of Local Officials-- -----	153

Data Sources are listed for each subsection.

# Introduction

Kenai Peninsula Borough (KPB) staff develops quarterly reports containing economic data from throughout the area for use by businesses, agencies, and other entities to make planning and management decisions.

The publication is divided into eight sections: Kenai Peninsula Borough, Homer, Kenai, Seldovia, Seward, Soldotna, KPB Unincorporated, and a Local Officials Directory.

To provide unity within the document, certain conventions are applied:

- In the real estate section, the following abbreviations apply:
  - RN - Residential New
  - RA - Residential Alteration/Addition
  - CN - Commercial New
  - CA - Commercial Alteration/Addition
  
- In Sales and Employment sections, the following industry abbreviations apply:
  - AFF – Agriculture, Forestry and Fisheries (Includes Fish Buyers)
  - Min – Mining (Includes Oil & Gas Extraction and Production)
  - Const – Construction
  - Manu – Manufacturing (Includes Oil & Gas Manufacturing and Fish Processing)
  - TCPU – Travel, Communications, and Public Utilities
  - Whole – Wholesale Trade
  - Retail – Retail Trade
  - FIRE – Finance, Insurance and Real Estate
  - Service – Services
  - Govt – Public Administration, Education and Service
  
- Information sources for each section are listed in the index.
  
- General information applicable to all sections is provided in the Kenai Peninsula Borough section.
  
- Percentages of parts may not total 100%, due to rounding.

Information presented will assist in decision-making by providing economic and demographic information in graphic, table and text form. Local and state government officials; local, state and federal agencies; businesses within the borough and elsewhere; and private citizens use data contained in the publication.

Data is received from various sources and is subject to change as updates, revisions and corrections are received. The KPB makes no claims to accuracy or completeness of information provided. Only summary information is published. For further detail, contact Jeanne Camp, Economic Analyst, KPB Community and Economic Development Division, 907-714-2336, or the data source listed in the index.

Quarterly reports are available electronically on the KPB website located at <http://www.borough.kenai.ak.us>.

**To correct your mailing address** or to be added to or deleted from the mailing list for this report, please email [jcamp@borough.kenai.ak.us](mailto:jcamp@borough.kenai.ak.us) or call 907-714-2336. Be certain to identify yourself and the complete mailing address to be added or deleted. For additions, an email address is appreciated, which will be used for notification of errors.

---

The Kenai Peninsula Borough wishes to thank all entities listed below for data provided for this publication.

Alaska Department of Labor and Workforce Development (AK DOL)

City of Homer

City of Kenai

City of Seldovia

City of Seward

City of Soldotna

Kenai Peninsula Borough Finance Department, Sales Tax Division

University of Alaska Fairbanks Cooperative Extension

---

The writer wishes to thank those persons who gave of their time to review this document to find errors and make suggestions that result in a more professional and accurate document. Those individuals include Jane Stein, Community Leader; Sylvia Vinson, KPB Planning Department; Betty Glick, Assembly Member; and Margaret Gilman, KPBSD Board Member.

## Functions of the CEDD and the EDD

Frequent questions regarding differences between KPB Community Economic Development Division (CEDD) and the Economic Development District (EDD) suggest the need for an explanation. The table below defines the differences.

	<b>CEDD</b>	<b>EDD</b>
<b>Funding</b>	Funded by KPB, federal and state grants	Funded by grants – federal, state, borough
<b>Powers</b>	Non area-wide economic development power, only unincorporated areas	Borough-wide economic development powers
<b>Projects</b>	Works on special projects for the mayor	Assists in KPB long-term economic planning
	Develops, monitors KPB grant funding	Sponsors community economic forums
	Publishes historical/current economic data	Assists in community strategic planning
	Oil and Gas liaison	

## What is a “Moving Average Trendline?”

Charts in the KPB economic reports frequently include “moving average trendlines.” After individuals read the documents, comments make their way back to the office. One comment that has been heard several times addresses these trendlines, noting that they are not labeled correctly. They are. A description of “trendline” is in order.

The purpose of a trendline is to demonstrate the average of data groupings and how that average relates to averages of similar groupings within the chart.

Imagine that a bar chart illustrates twelve quarters of data. The trendline begins at the fourth entry in the series and marks the point representing the average of the first through the fourth numbers in the series, in this case a 1<sup>st</sup>, 2<sup>nd</sup>, 3<sup>rd</sup> and 4<sup>th</sup> quarter value, one year. The trendline continues to the right in the chart. As the trendline reaches the next entry in the series, the line will move to the point on the scale representing the average of the second through the fifth entries in the series – still four quarters of data, but this time those values would be the 2<sup>nd</sup>, 3<sup>rd</sup> and 4<sup>th</sup> quarter of the first year plus the 1<sup>st</sup> quarter of the second year.

The process continues through the chart. As the line moves through the chart, it drops the entry marking the beginning of the trend point average, adds the entry just ahead of the previous set of four and indicates the average of the new set of four numbers in the series. The resulting “smoothing” effect allows the reader to more easily see change from one year to the next.

# Executive Summary

Property taxes, employment, sales tax revenues and disposable income are viewed as the key factors in an economy. As both volume and value of construction in the Kenai Peninsula Borough are increasing, property tax revenues increase. Employment has trended upward for the past several years, with both a larger labor force and increased employment, accompanied by decreasing unemployment rates. Both gross sales and taxable sales are at record highs, indicating that sales tax revenues are also at record highs. Per capita income continues to increase as well, which in theory, increases disposable income as long as inflation is kept under control. With those facts in mind, it is clear that the Kenai Peninsula Borough economy is a healthy economy.

Second quarter gross sales increased 12.3% from \$464,388,613 during second quarter 2004 to \$521,606,851 during 2005, a \$57,218,238 increase. Taxable sales gained 3.7% to reach \$214,690,22, up from \$207,034,918 one year ago, a \$7,655,304 increase. Construction activity gained momentum as permit values for the period increased 5.3% to \$21,767,075 and volume increased 37.7% from 106 permits a year ago to 146 for second quarter 2005.

With the exception of January, the labor force has set new highs each month for the first six months of the year. Only four years have experienced lower unemployment during June than June of 2005 and only two years (2000 and 2001) have had lower unemployment rates than June of this year. The May unemployment rate tied for the low record. Employment is at record highs for all months except January. Employment data since 1990 has recently been updated by the Alaska Department of Labor,

The oil & gas industry remains in the spotlight with recent issues and developments. Agrium has received proposals for gas supplies, which may allow them to delay the announced closure or even disregard plans for shutdown of operations. The announced closure was a factor in disputes over operation of the Cook Inlet Gas Gathering System (CIGGS), which passes through state lands or waters so must be regulated as a common carrier or gas utility pipeline. Unocal received two offers for purchase; a proposal from Chevron that has been accepted, and a controversial offer by CNOOC, a company based in China, which has been rejected. Three offers are being evaluated by the State for building a natural gas pipeline, each with it's own set of options for route, destination, and product. Concern in the Peninsula is for a natural gas supply to meet local residential needs as well as needs of area plants that use or process natural gas and employ local residents. A plan gaining area support is a bullet line, which would be a smaller diameter, lower pressure line delivering natural gas to the Peninsula from the North Slope fields. Incentives to spur exploration in the Cook Inlet are being considered, as well as means of bringing a jack-up rig for that exploration. The average daily rate of a jack-up rig at year-end 2004 was \$57,500. The cost of mobilization to Alaska waters is estimated to be between \$12 and \$20 million.

Area businesses are seeing the first of the summer tourists with initial reports indicating a strong visitor season.

Commercial fishers are set for a busy summer with projections of a strong return of sockeye salmon. Kenai Wild, the community based non-profit regional salmon brand, is set for a fourth year of operation with four processors and nearly 200 members. Markets are expanding throughout the United States and into the European Union.

# Executive Summary

A nutraceuticals plant, Denali Biotechnologies, has established a presence in the KPB, an addition to the manufacturing sector. Their headquarters are located in the KPB but they purchase wild blueberries from native and private landowners, statewide.

## SALES

Second quarter 2005 gross sales of \$521,606,851 were 12.3% more than the \$464,388,613 in sales occurring during 2004, a difference of \$57,218,238. Taxable sales increased 3.7% from \$207,034,918 during 2004 to \$214,690,222 during the most recent quarter, with six of ten sectors experiencing increasing sales. Retail sales provided 60.2% of taxable sales and produced both the greatest numerical and percentage increase, gaining \$6,908,668 and 5.6%. Quarterly sales data may be skewed in certain industries because businesses that consistently report less than \$6,000 in taxable sales annually may be allowed to report sales on an annual basis.

### Quarterly Sales

**Gross by Industry.** Reported gross sales reached \$521,606,851 during second quarter 2005, a gain of 12.3% over the \$464,388,613 reported one year earlier. Transportation, Communications and Public Utilities (TCPU) sales increased 87.2%, from \$35,418,629 during second quarter 2004 to \$66,292,744 during the most recent quarter, a gain of \$30,874,115. Construction sales experienced 52.5% growth with sales of \$64,647,351, surpassing second quarter 2004 sales of \$42,383,490 by \$22,263,861. Agriculture, Forestry and Fishing (AFF) sales increased \$1,818,983 or 46.5% from \$3,911,032 to \$5,730,015. Manufacturing sales gained 27.6%, as sales grew from \$15,540,229 to \$19,822,789 for a \$4,282,560 gain. All other gains were single digit gains as Finance, Insurance and Real Estate (FIRE) sales of \$15,613,560 were up 8.4% from the \$14,399,905 in sales reported one year ago. Mining sales of \$33,964,675 were 5.8% greater than last year's \$32,098,347. Retail sales increased 5.8% or \$10,868,745, from \$187,716,055 during second quarter 2004 to \$198,584,800 during second quarter 2005.

Three industries experienced sales declines with sale of wholesale goods showing the greatest decline, 30.2% with sales of \$35,333,081, down from \$50,630,515 during second quarter of 2004. Sales in the service sector were down 0.8% from the \$82,281,890 in sales reported one year ago to \$81,609,334 second quarter this year. Government sales of \$8,502 are inconsequential, but were down 0.2%. (See page 15 for detail.)

**Taxable by Industry.** Taxable sales continued their seemingly constant trend upward, gaining 3.7% over a year ago, with total sales of \$214,690,222, a gain of \$7,655,304 for the quarter. Sales during second quarter 2004 reached \$207,034,918. Retail sales make up 60.2% of total taxable sales, and increased 5.6% over 2004 with sales of \$129,288,137. Last year, those sales totaled \$122,379,469. The \$6,908,668 retail sales gain accounted for just over 90% of the overall taxable sales gain. Construction sales were up 3.6% from \$2,922,202 to \$3,028,610. AFF sales increased 3.3% from \$1,674,503 to \$1,730,585. TCPU sales increased 2.5% from \$19,473,926 to \$19,955,815 while sale of wholesale goods totaled \$6,694,933, increasing 1.4% over second quarter 2004 when sales reached \$6,600,388. The second largest sector, services, saw sales increase 0.6% from \$44,443,654 to \$44,693,390.

# Executive Summary

While overall taxable sales increased, four sectors did experience declining sales. Both manufacturing and FIRE saw sales decline 2.2% with sales of \$2,677,623 and \$5,585,453, respectively. The mining sector reported \$1,027,174 in taxable sales for the quarter, down 5.1% from second quarter 2004. Finally, the \$8,502 in government sales marked a 0.2% decrease. (See page 16 for detail.)

**Gross by Area.** With gross sales up 12.3%, five of six KPB reporting areas experienced gains to total \$521,606,851 in sales for the quarter. Both Kenai and Seward saw gross sales increase 33.6%. Kenai experienced strength in TCPU sales to bring total sales to \$99,203,608 while Seward sales reached \$57,117,577 as construction sales spiked. Homer followed with a 22.2% gain to reach \$84,293,052 with strength in TCPU sales as well. Seldovia sales increased 5.7% to \$2,084,625. Lastly, sales in the Other KPB region reached \$193,977,222, gaining 3.7%.

Soldotna, the only declining region, had sales of \$84,930,767, down 4.9% from the \$89,308,815 in gross sales during second quarter 2004. (See detail on page 17.)

**Taxable by Area.** As with gross sales, only one of the six regions experienced declines for the quarter as taxable sales across the KPB totaled \$214,690,222, a gain \$7,654,304 over second quarter 2004. All changes were single-digit gains or declines for a KPB gain of 3.7%. Seward sales increased 8.9% from \$22,997,045 to \$25,039,952. Soldotna's \$51,098,338 in sales marked a 4.3% increase over last year when sales reached \$49,010,429. Sales in the Other KPB region grew by 3.3% to total \$60,105,978, increasing from \$58,187,673. Kenai sales increased from \$36,252,658 to \$37,280,735, a 2.8% gain. Finally, Homer sales reached \$40,238,511, a 1.5% increase over 2004 second quarter sales of \$39,648,524.

Only Seldovia experienced a decline in taxable sales. Sales of \$926,708 were down 1.4% from the \$939,589 of one year ago. (See detail on page 18.)

## Year-to-Date 6/30 Sales

**Gross by Industry.** Year-to-date June 30 sales of \$925,080,204 increased over those of one year ago when sales reached \$825,264,770. The 12.1% gain is equivalent to \$99,815,434 in sales. TCPU sales increased \$50,292,092 to reach \$124,677,770, a 67.6% gain. Construction sales increased \$35,921,857 or 50.6% to \$106,947,858. Retail sales grew \$15,231,957 to reach \$329,788,507 for a 4.8% gain. Sales in manufacturing were \$12,017,601 greater than one year ago, reaching \$53,664,855, a 28.9% increase. AFF sales totaled \$8,704,051, gaining \$2,452,093 or 39.2%. Service sales increased \$2,060,798, reaching \$127,422,071 for a 1.6% increase. Lastly, mining sales gained \$1,896,543 or 2.6% to total \$73,796,284. Inconsequential government sales of \$23,716 were up 6.9%.

Only two industry sectors experienced declining sales. Sale of wholesale goods declined 21.5% to \$72,567,868, down \$19,845,418. FIRE sales decreased 0.8% from \$27,700,815 to \$27,487,194, a drop of \$213,621. (See detail on page 19.)

**Taxable by Industry.** Five of ten industries report sales gains during the first six months of 2005 over those of 2004 with sales of \$358,965,287 with all changes in single-digit range. The large retail sector grew by \$9,565,939 in taxable sales, 4.7%, to total \$215,105,985. TCPU

# Executive Summary

sector sales increased \$2,540,676 or 6.3%, reaching \$43,036,143. Services grew \$590,985 or 0.9% to \$64,286,395. The \$114,471 increase in AFF sales brought sales to \$2,678,251 for 4.5%. Lastly, government sales increased 7.2% to \$23,716.

The \$337,271 decrease in FIRE sales marked a 3.2% decrease, with sales dropping to \$10,263,709 for the first two quarters of the year. Manufacturing sales decreased \$227,465 or 5.4%, to \$4,022,366. Wholesale good sales were down \$174,331 or 1.4% to \$12,318,487. Construction and mining sales were down \$23,980 and \$15,168, respectively. Construction sales topped out at \$5,115,004 while mining sales totaled \$2,115,004. (See detail on page 20.)

**Gross by Area.** Year to date June 30 sales were marked by increases in four areas and declining sales in two, resulting in a 12.1% gain over all. Seward sales led the way, gaining 30.7% and reaching \$83,576,862. Kenai's gain followed closely, 29.1%, with sales of \$174,708,908. Homer also had double-digit gains for the first half of 2005 with sales increasing \$19,061,617 or 16.3%, reaching \$136,181,405. The Other KPB region saw sales increase \$30,136,992 or 8.7% to \$376,400,737.

Sales in Soldotna declined \$8,353,703 to \$150,866,600, a 5.2% drop. Seldovia sales, \$3,345,692, were down 0.9% or \$31,025 from one year ago. (See detail on page 21.)

**Taxable by Area.** As KPB taxable sales increased 3.5% overall, Seward taxable sales gained 8.1% over a year ago with sales of \$35,131,352, compared to \$32,491,809 a year ago. Soldotna sales, \$89,832,191, were 4.0% greater than the \$86,393,757 in sales reported last year. Other KPB sales also increased 4.0%, moving upwards from \$97,268,860 to \$101,153,762. Homer sales gained 1.7% to \$64,574,690 from \$63,473,444 a year ago. Finally, Kenai sales increased 1.5% to \$66,774,067 from \$67,798,649 a year ago.

Only Seldovia experienced declining sales as taxable sales for the first six months of the year dropped 0.5% to \$1,499,225. (See detail on page 22.)

## Annual Sales

KPB 2004 annual gross sales of \$2,222,411,066 were 15.7% above those of 2003 as seven sectors had improved sales while three sectors had declining sales, most with double-digit change. All reporting areas had increased sales for the year.

Taxable sales increased 6.5% from 2003 to 2004 with sales of \$780,203,973 as seven sectors reported increased sales while three had declining sales. Each of the six reporting areas had increased taxable sales for the year.

**Gross by Industry.** KPB annual gross sales increased 15.7% during 2004 over 2003 sales, with all reported sales reaching \$2,222,411,066, the first year to pass the \$2 billion mark. The largest percentage gain came in wholesale goods with an 88.8% increase and \$366,603,918 in sales. The mining sector also had a large gain, 55.2% with sales totaling \$165,354,111. AFF sales of \$27,631,235 were 25.5% greater than those of 2003 while TCPU sales increased 14.3% to \$181,051,679. Service sales increased 11.1% and FIRE sales increased 10.8% with reported sales of \$309,254,338 and \$64,300,864, respectively. Lastly, the large retail sector gained 8.6%.



# Executive Summary

While retail sales had the smallest percentage increase, the sales increased \$55,284,039 to \$699,981,425.

Three sectors had decreasing sales for the year. Manufacturing sales declined 14.4% from 2003 with sales dropping to \$170,708,461 and construction sales dropped to \$237,489,930, down 8.1%. The inconsequential \$35,105 in government sales marked a 16.4% decrease. (See detail on page 23.)

**Taxable by Industry.** KPB taxable sales increased 6.5% during 2004 to total \$780,203,973. Retail sales, first in size and in numerical increase, increased by \$32,489,307 or 7.6%, reaching \$461,757,359. The service industry, second in size and second in increase, gained \$10,155,800 or 7.0% to total \$154,901,038. Also increasing sales by millions, sale of wholesale goods increased \$2,008,455 or 8.3% to reach \$26,290,768 and TCPU sales increased to \$82,707,524 a gain of \$1,334,014 or 1.6%. Manufacturing and mining gained \$620,460 and \$617,038 in sales, respectively. Manufacturing sales increased 6.7% to reach \$9,859,946 and mining sales gained 12.6% totaling \$5,502,300. AFF sales rose 10.3% or \$514,282 to reach \$5,525,243.

Construction sales declined 0.1% to \$11,272,667, down \$10,685 while FIRE sales decreased 1.8% to \$22,352,088, a sales drop of \$399,741. Government's 16.5% sales decline is inconsequential at \$35,040. (See detail on page 24.)

**Gross by Area.** As KPB 2004 sales grew by 15.7%, all sub areas also reported increased sales. Kenai gross sales expanded 65.6%, reaching \$469,314,722 for the year, due to strength in the TCPU sector. Seldovia, with \$8,325,201 in sales, marked a 14.7% gain. Sales in the Other KPB region increased 8.5% to \$933,679,762 while Soldotna sales increased 6.9% to reach \$361,195,645. Seward and Homer sales increased 5.9% and 3.5% respectively. Seward sales totaled \$166,213,217 and Homer sales reached \$283,682,519 for the year. (See detail on page 25.)

**Taxable by Area.** As with gross sales, 2004 taxable sales rose in all areas of the KPB, increasing 6.5% to total \$780,203,973. Kenai, the only double-digit gainer, increased 14.3% to \$138,630,979. Homer taxable sales increased 6.3% to \$140,002,852 while Soldotna sales gained 5.0% to total \$200,052,811. Seward sales of \$79,945,206 marked a 4.7% increase while Seldovia sales increased 0.1% with \$3,381,682 in reported sales. (See detail on page 26.)

## CONSTRUCTION PERMITTING

Because the KPB does not require building permits, activity portrayed in this section does not show all activity. Building projects permitted within the five cities that do require permits are shown. In addition, construction projects other than buildings are also not listed. Cases in point would be road construction projects, or other public works projects, and signage permitting which is not detailed in this section.

Second quarter 2005 values and volume of permitting activity each exceeded 2004 levels and set new record highs with 146 permits being issued with a total assessed value of \$21,737,075.

# Executive Summary

## Quarterly Permitting

**By Area, Value.** KPB permits values during the first half of 2005 had a total assessed value of \$21,767,075. Homer permitting provided 51.6% of quarterly value, issuing permits totaling \$11,242,000. Soldotna's total permit value of \$6,832,235 provided 31.4% of the borough-wide total. Kenai issued \$2,557,300 in permit value while Seward issued \$669,540, adding 11.7% and 3.1% of the total, respectively. Seldovia issued building permits with a total assessed value of \$466,000. With the exception of Seward, all areas had greater permitted values during second quarter 2005 than during second quarter 2004. (See detail on page 31.)

**By Area, Volume.** There were 146 permits issued in the KPB as of June 30, 2005, forty more than the 106 permitted to date during 2004. Homer issued 46 permits, twenty more than one year ago, and 31.5% of KPB's second quarter total. Soldotna issued 40 permits, fourteen more than one year ago and 27.4% of the total. Kenai increased permitting from 30 to 33 for the quarter, 22.6% of the total while Seward was stable at 21 permits. Lastly, Seldovia doubled activity issuing 6 permits with 4.1% of Borough activity. (See detail on page 32.)

**By Type, Value.** New commercial permit values provided 53.7% of value with \$11,692,848 in assessed value permitting during second quarter 2005. New residential permits added 34.7% of the total value with \$7,560,499 in value. Commercial alteration/addition permit values of \$1,679,958 provided 7.7% of the total while residential alteration permits issued during the quarter had a total value of \$833,770. (See detail on page 33.)

**By Type, Volume.** Of the 146 permits issued during the quarter, 49 were issued for construction of new homes and 23 were issued for new commercial structures. An additional 22 permits were issued for commercial alterations and 52 for residential alteration. (See detail on page 34.)

## Year-to-Date Permitting

Year-to-date June 30 permit values dropped 24.8% from 2004 levels but produced the third highest permitted value on record, \$28,242,330 down from the second quarter 2004 level of \$37,531,727. The record setting year occurred during 1995 when the Seward SeaLife Center was permitted. Permit volume of 204 sets a new high and is 31 permits greater than the previous high of 173 permits issued YTD 2002.

**By Area, Value.** Homer issued \$14,347,900 for 50.8% of the total KPB value for the first half of 2005. Soldotna followed with \$8,253,790 and 29.2% of the total. Kenai, issuing 10.6% of the value, permitted \$2,982,800 in construction projects, while Seward issued permits with assessed values totaling \$2,176,840 for 7.7%. Seldovia has issued permits totaling \$481,000 in assessed value. (See detail on page 35.)

**By Area, Volume.** All areas increased year-to-date permitting from 2004 to 2005 as total permitting increased from 143 to 204 permits, a 42.7% increase. Homer's 64 permits surpassed the 42 permits issued during the first six months of 2004 by 52.4% and provided 31.4% of Borough permit activity. Soldotna issued 56 permits, 60.0% greater than the 35 issued a year

# Executive Summary

ago. The 43 permits issued in Kenai improved 26.5% over the 34 issued for the same period during 2004. Seward issued 34 permits, increasing from 28 and Seldovia issued seven permits, up from the four issued 2004 YTD. (See detail on page 36.)

**By Type, Value.** Assessed permit values decreased 24.8% from \$37,531,727 to \$28,242,330 as new commercial structure values decreased 49.2% from \$24,027,841 to \$12,201,848. This is reasonable due to three major projects that were permitted last year in Soldotna alone. Each of the other three categories improved in value. New residential total value was strong with permits totaling \$11,030,855, 12.2% greater than the \$9,831,284 issued during 2004. Commercial alteration added \$3,756,927 and residential alteration another \$1,252,700 to the total. (See detail on page 37.)

**By Type, Volume.** Of the 204 permits issued during the first two quarters of 2005, 65.6% were for residential projects. Sixty-seven permits each were issued for new homes and for residential alterations or additions. Commercial alterations added 41 permits and new commercial permits provided the other 29. (See detail on page 38.)

## Annual Construction - Year 2004

Construction permits are required by KPB cities, but not by the KPB, resulting in incomplete construction activity data. Permit values during 2004 totaled \$84,041,457, a 92.7% increase over 2003 and the highest total value on record. There were 312 permits issued during 2004, 7.1% fewer than the 336 issued during 2003, but third highest on record.

**By Area, Value.** Soldotna's \$37,296,926 in construction permit assessed values provided 44.4% of KPB 2004 annual value; a 369.0% increase over 2003 permit values. Homer's \$24,070,631 total value added 28.6% to the KPB total, marking a 57.0% increase over 2003. Seward permit values increased 121.9% for the year to \$17,711,150, providing 21.1% of the annual total. Kenai permit values dropped 54.2% to \$4,786,550, providing 5.7% of the KPB total. Seldovia's \$176,200 value provided the remaining 0.2%. (See detail on page 39.)

**By Area, Volume.** During 2004 Homer issued 108 of the 312 permits, providing 34.6% of the KPB total. Kenai issued 79 permits while Soldotna issued 67 permits, 25.3% and 21.5%, respectively. Seward issued 54 permits, 17.3% of the total while Seldovia's 4 permits added 1.3% of the volume. Homer and Seward increased permit volume over 2003 with Homer issuing 25.6% more permits than one year ago and Seward's count increased by 8.0%.

On the other side, areas with declining permit activity include Kenai, down 30.7%, Soldotna was down 9.5% and Seldovia issued 66.7% less than one year ago. Total Borough permitting was down 7.1% from the 2003 level. (See detail on page 40.)

**By Type, Value.** Total permit values for 2004 were 92.7% greater than those of 2003. The value of those permits was \$84,041,457. New projects provided 85.7% of permit activity with commercial and residential permits providing 66.7% and 19.0% of the total, respectively. New commercial values of \$56,079,343 led the way with new residential permit values totaling \$15,935,344. Commercial alteration/addition permit values totaled \$9,146,486 or 10.9% of the total. Finally, residential alteration/addition permits added \$2,880,284 for 3.4% of the KPB

# Executive Summary

total. New commercial permit values were 254.5% above 2003 while residential alteration/addition values were up 26.3%. New residential values increased 1.3% but commercial alteration/addition total value was down 6.4%. (See detail on page 41.)

**By Type, Volume.** Commercial alteration/addition annual activity for 2003 decreased 7.1% to 312 permits from 336 during 2003. New residential activity shows 94 permits were issued down from 104 permits each of the last two years. Ninety-six residential alteration/addition permits were issued, 2.1% more than during 2003. New commercial activity was stable at 42 permits while commercial alteration/addition activity dropped from 96 to 80 permits. (See detail on page 42.)

## EMPLOYMENT

Employment data has been revised and a change in the way labor force statistics are calculated for boroughs and census areas make data prior to 2000 not comparable with data from 2000 forward.

KPB's labor force continues to increase, with seasonal peaks during the busy summer months. The reported 27,751 workers during June 2005 marks an all time high, even as population statistics indicate a decline in population. This is 634 persons greater than June one year ago. The May labor force of 25,830 was 528 workers more than one year ago. Available workers during April numbered 24,749, this was 619 greater than April of 2004. The labor force during February and March was 220 and 165 greater than last year, respectively. Lastly, the January 2005 labor force was 23,873, one person less than a year ago.

There were 1,983 persons were listed as unemployed in the KPB during June 2005, down 436 persons from June 2004. May unemployment was reported at 1,891, that is 381 less than during 2004. April data indicated 2,227 persons were unemployed, 281 less than April 2004. All three months were near record lows.

KPB's 2005 unemployment rates have trended downward, beginning at 11.3% during January, moving step by step, month by month to 11.4%, 10.0%, 9.0%, 7.3% and finally to 7.1% during June. The June 2005 rate is nearly two percentage points below the June 2004 rate of 8.9%.

As unemployment decreased, employment increased month-by-month. Employment during January 2005 was reported at 21,183 persons. Each month moved higher with February at 21,457, to 21,864, 22,522, 23,939 and on up to 25,768 during June. There were 1,070 more persons working during June 2005 than during June 2004. (See detail on pages 47-51.)

## POPULATION

Population estimates for 2004 show the Kenai Peninsula population at 50,980 persons, a 0.8% decrease for the year. Each of the incorporated cities also marked decreases. Homer dropped 9.1% to 5,332 while Kachemak City lost 0.6% to a total of 475 persons. Kenai also decreased, losing 4.4% to 6,809 residents. Seldovia decreased 5.7% to 263 and Seward lost 7.5%, down to 2,540 persons. Soldotna's population is down 5.6% to 3,767. Alaska's population, estimated at 655,435 for 2004, marked a 1.1% increase for the year. (See page 54 for detail.)

# KPB Sales

Sales tax records provide data useful for predicting economic trends and provide a basis for administrative decisions. Data collected are specific to the area collecting and reporting sales; but, by combining data from reporting communities, KPB trends can be determined. Routinely, three years or twelve quarters of information are revised each quarter. Sales data is provided by the KPB Finance Department, Sales Tax Division and include detail from Homer, Kenai, Seldovia, Seward, Soldotna and “Other KPB” areas. “Other KPB” indicates areas within the KPB but outside the boundaries of five incorporated cities. It also includes Kachemak City, which does not impose a sales tax. The 2% KPB sales tax is included in the city rates listed below, with revenues dedicated to funding the KPB school district. The balance is the tax imposed by each city with revenues being managed by that city.

The KPB does not provide an incentive for reporting non-taxable sales, resulting in incomplete Gross Sales data.

6.5%	5.5%	5.0%	4.0%	2.0%
Seldovia	Homer	Kenai	Seldovia	Other KPB
(April - September)		Seward	(October - March)	
		Soldotna		

Gross and Taxable Sales data are generally received quarterly through Sales Tax Returns from businesses within the KPB. Some businesses are required to report monthly while others with very low taxable sales may report on an annual basis. Sales that are exempt from sales tax include:

- Sales outside the borough;
- Sales for resale;
- Sales to government agencies;
- Sales to tax exempt organizations; and
- Sales in excess of \$500.

Industry abbreviations used in sales data include the following:

- AFF - Agriculture, Forestry and Fisheries - includes fish buyers;
- Min - Mining - includes Oil & Gas extraction and production;
- Const - Construction;
- Manu - Manufacturing - includes Oil & Gas Manufacturing and Fish Processing;
- TCPU - Travel, Communications and Public Utilities;
- Whole - Wholesale Trade;
- Retail - Retail Trade;
- FIRE - Finance, Insurance and Real Estate;
- Service - Services;
- Govt - Public Administration, Education and Services.

# KPB Sales

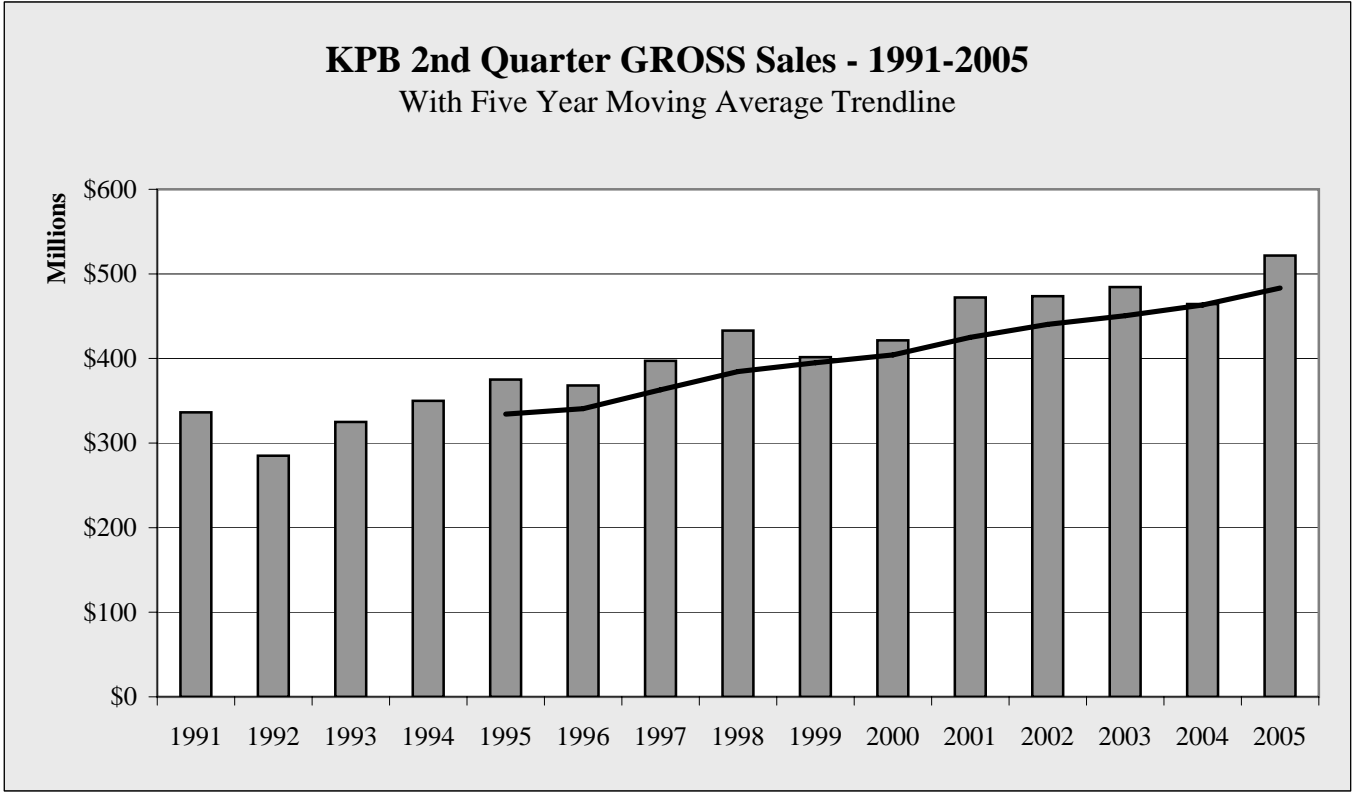

Chart 1.1

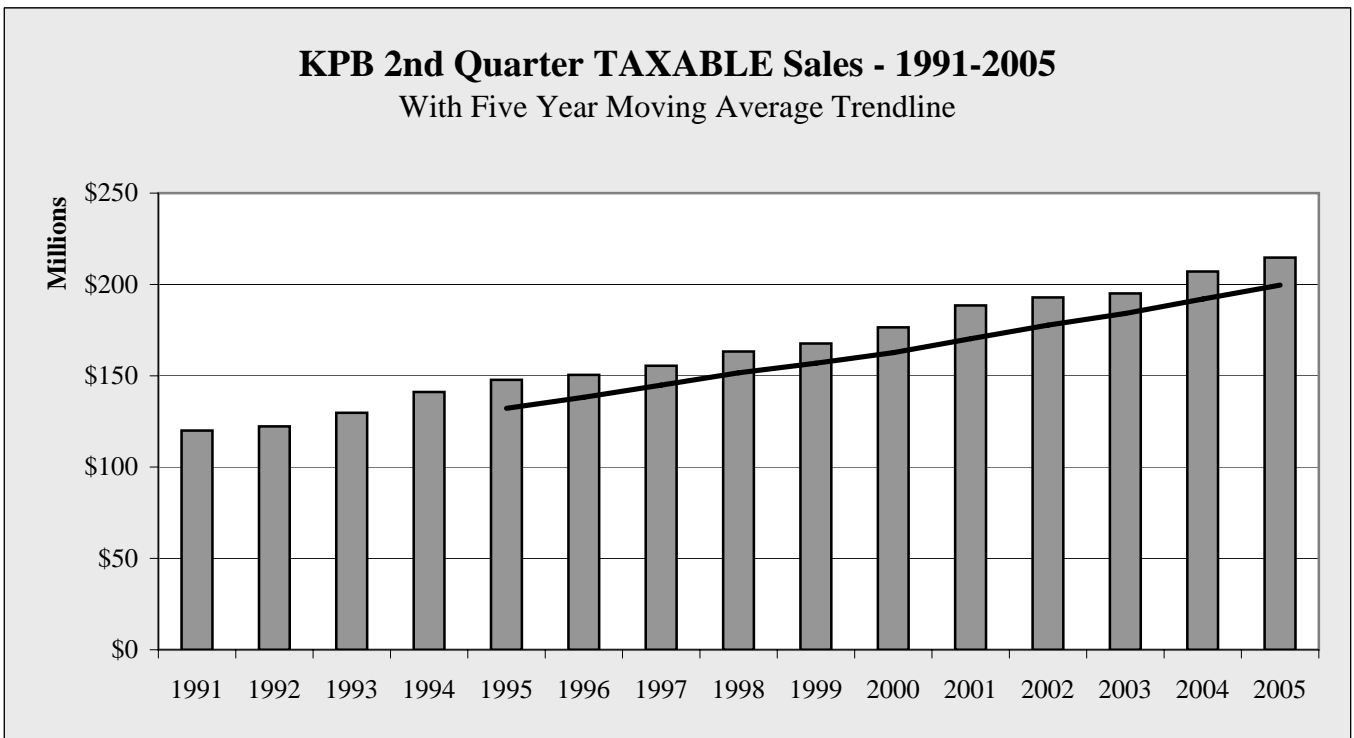

Chart 1.2

# KPB Sales

KPB 2nd Quarter GROSS Sales by INDUSTRY - 1999-2005 - in \$								
	1999	2000	2001	2002	2003	2004	2005	Annual Change
AFF	3,016,519	5,319,721	2,803,392	2,856,503	4,045,723	3,911,032	5,730,015	46.5%
Min	25,470,340	26,743,730	26,110,361	29,861,507	25,083,685	32,098,347	33,964,675	5.8%
Const	36,768,351	43,050,334	51,568,925	49,852,546	67,758,953	42,383,490	64,647,351	52.5%
Manu	38,595,274	33,981,714	56,672,953	44,663,448	34,259,747	15,540,229	19,822,789	27.6%
TCPU	40,730,993	37,904,376	40,127,980	42,378,179	38,841,966	35,418,629	66,292,744	87.2%
Whole	38,520,176	44,471,620	44,103,011	46,538,996	50,841,751	50,630,515	35,333,081	-30.2%
Retail	145,098,963	150,169,853	166,794,245	165,285,986	170,711,911	187,716,055	198,584,800	5.8%
FIRE	13,250,405	13,361,306	13,531,404	14,756,677	15,275,186	14,399,905	15,613,560	8.4%
Service	60,032,451	66,471,325	70,429,963	77,421,202	77,645,713	82,281,890	81,609,334	-0.8%
Govt	6,881	5,835	5,238	7,859	8,680	8,521	8,502	-0.2%
Total	401,490,353	421,479,814	472,147,472	473,622,903	484,473,315	464,388,613	521,606,851	12.3%
Annual Change		5.0%	12.0%	0.3%	2.3%	-4.1%	12.3%	

Table 1.1

KPB 2nd Quarter GROSS Sales Ten Year Change by INDUSTRY - 1995-2005 - in \$				
			10 Year Change	
	1995	2005	Percentage	Numerical
AFF	19,655,012	5,730,015	-70.8%	-13,924,997
Min	21,440,297	33,964,675	58.4%	12,524,378
Const	33,210,334	64,647,351	94.7%	31,437,017
Manu	37,246,429	19,822,789	-46.8%	-17,423,640
TCPU	55,822,677	66,292,744	18.8%	10,470,067
Whole	32,707,887	35,333,081	8.0%	2,625,194
Retail	116,003,856	198,584,800	71.2%	82,580,944
FIRE	9,734,115	15,613,560	60.4%	5,879,445
Service	49,317,186	81,609,334	65.5%	32,292,148
Govt	3,094	8,502	174.8%	5,408
Total	375,140,887	521,606,851	39.0%	146,465,964

Table 1.2

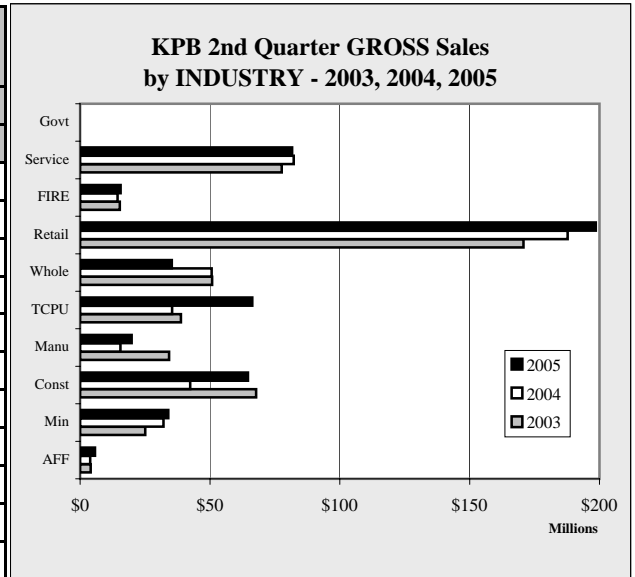

Chart 1.3

KPB 2nd Quarter GROSS Sales One Year Change by INDUSTRY - 2004-2005 - in \$				
			1 Year Change	
	2004	2005	Percentage	Numerical
AFF	3,911,032	5,730,015	46.5%	1,818,983
Min	32,098,347	33,964,675	5.8%	1,866,328
Const	42,383,490	64,647,351	52.5%	22,263,861
Manu	15,540,229	19,822,789	27.6%	4,282,560
TCPU	35,418,629	66,292,744	87.2%	30,874,115
Whole	50,630,515	35,333,081	-30.2%	-15,297,434
Retail	187,716,055	198,584,800	5.8%	10,868,745
FIRE	14,399,905	15,613,560	8.4%	1,213,655
Service	82,281,890	81,609,334	-0.8%	-672,556
Govt	8,521	8,502	-0.2%	-19
Total	464,388,613	521,606,851	12.3%	57,218,238

Table 1.3

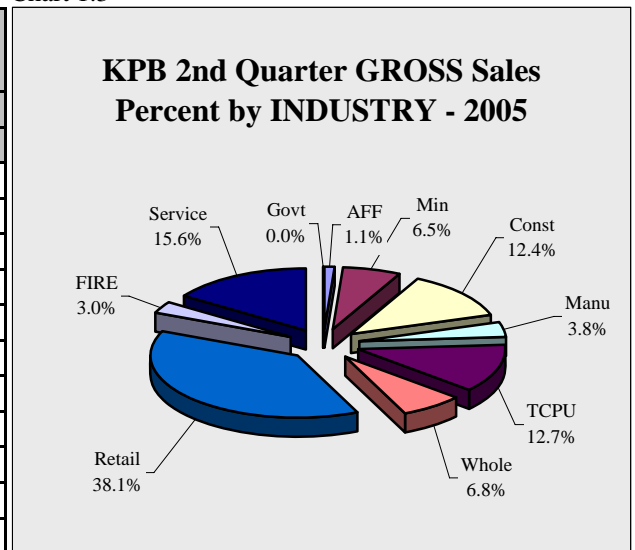

Chart 1.4

# KPB Sales

KPB 2nd Quarter TAXABLE Sales by INDUSTRY - 1999-2005 - in \$								
	1999	2000	2001	2002	2003	2004	2005	Annual Change
AFF	1,087,418	1,259,115	1,401,861	1,423,988	1,577,278	1,674,503	1,730,585	3.3%
Min	936,119	1,086,368	1,349,445	1,484,251	1,170,493	1,082,504	1,027,174	-5.1%
Const	2,452,936	2,476,890	2,526,383	2,677,823	3,128,868	2,922,202	3,028,610	3.6%
Manu	2,644,412	2,809,920	2,885,132	2,791,765	2,607,213	2,737,701	2,677,623	-2.2%
TCPU	18,580,759	19,151,919	19,064,716	21,477,202	20,321,138	19,473,926	19,955,815	2.5%
Whole	4,704,744	5,579,186	5,794,250	5,679,123	6,337,983	6,600,388	6,694,933	1.4%
Retail	95,045,828	99,715,539	108,655,727	109,883,510	112,417,564	122,379,469	129,288,137	5.6%
FIRE	4,899,070	5,115,328	5,949,812	6,078,006	5,975,269	5,712,050	5,585,453	-2.2%
Service	37,260,491	39,296,503	40,842,035	41,353,274	41,519,812	44,443,654	44,693,390	0.6%
Govt	6,881	5,835	5,238	7,859	8,680	8,521	8,502	-0.2%
Total	167,618,658	176,496,603	188,474,599	192,856,801	195,064,298	207,034,918	214,690,222	3.7%
Annual Change		5.3%	6.8%	2.3%	1.1%	6.1%	3.7%	

Table 1.4

KPB 2nd Quarter TAXABLE Sales Ten Year Change by INDUSTRY - 1995-2005 - in \$				
			10 Year Change	
	1995	2005	Percentage	Numerical
AFF	1,040,829	1,730,585	66.3%	689,756
Min	1,107,810	1,027,174	-7.3%	-80,636
Const	2,150,526	3,028,610	40.8%	878,084
Manu	2,342,028	2,677,623	14.3%	335,595
TCPU	16,150,625	19,955,815	23.6%	3,805,190
Whole	5,229,717	6,694,933	28.0%	1,465,216
Retail	83,080,137	129,288,137	55.6%	46,208,000
FIRE	4,792,222	5,585,453	16.6%	793,231
Service	31,858,642	44,693,390	40.3%	12,834,748
Govt	3,094	8,502	174.8%	5,408
Total	147,755,630	214,690,222	45.3%	66,934,592

Table 1.5

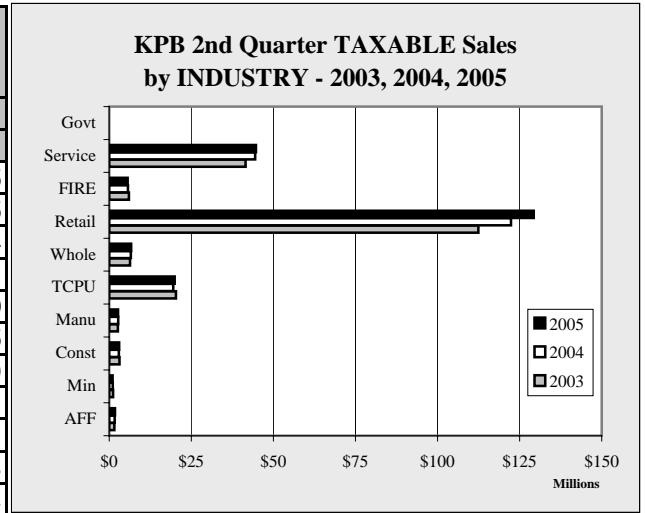

Chart 1.5

KPB 2nd Quarter TAXABLE Sales One Year Change by INDUSTRY - 2004-2005 - in \$				
			1 Year Change	
	2004	2005	Percentage	Numerical
AFF	1,674,503	1,730,585	3.3%	56,082
Min	1,082,504	1,027,174	-5.1%	-55,330
Const	2,922,202	3,028,610	3.6%	106,408
Manu	2,737,701	2,677,623	-2.2%	-60,078
TCPU	19,473,926	19,955,815	2.5%	481,889
Whole	6,600,388	6,694,933	1.4%	94,545
Retail	122,379,469	129,288,137	5.6%	6,908,668
FIRE	5,712,050	5,585,453	-2.2%	-126,597
Service	44,443,654	44,693,390	0.6%	249,736
Govt	8,521	8,502	-0.2%	-19
Total	207,034,918	214,690,222	3.7%	7,655,304

Table 1.6

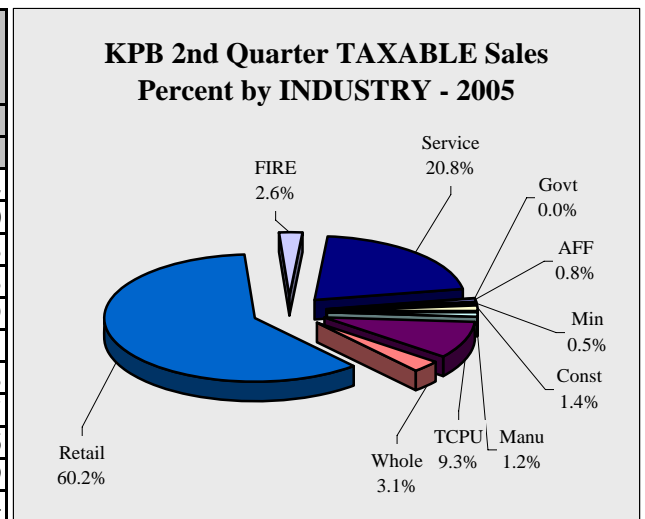

Chart 1.6



# KPB Sales

KPB 2nd Quarter GROSS Sales by AREA - 1999-2005 - in \$								
	1999	2000	2001	2002	2003	2004	2005	Annual Change
Homer	53,871,188	59,287,582	56,857,475	68,671,745	75,287,944	68,978,475	84,293,052	22.2%
Kenai	61,605,164	66,158,563	76,673,936	67,929,291	67,424,299	74,275,624	99,203,608	33.6%
Seldovia	1,388,188	1,526,900	1,473,305	1,155,055	1,629,455	1,971,670	2,084,625	5.7%
Seward	36,041,325	38,014,037	44,452,278	40,385,376	46,984,153	42,760,800	57,117,577	33.6%
Soldotna	67,874,942	72,515,215	75,042,511	79,761,648	85,179,197	89,308,815	84,930,767	-4.9%
Other KPB	180,709,546	183,977,517	217,647,967	215,719,788	207,968,267	187,093,229	193,977,222	3.7%
Total	401,490,353	421,479,814	472,147,472	473,622,903	484,473,315	464,388,613	521,606,851	12.3%
Annual Change		5.0%	12.0%	0.3%	2.3%	-4.1%	12.3%	

Table 1.7

KPB 2nd Quarter GROSS Sales Ten Year Change by AREA - 1995-2005 - in \$				
			10 Year Change	
	1995	2005	Percentage	Numerical
Homer	48,092,891	84,293,052	75.3%	36,200,161
Kenai	63,194,041	99,203,608	57.0%	36,009,567
Seldovia	1,802,578	2,084,625	15.6%	282,047
Seward	31,743,226	57,117,577	79.9%	25,374,351
Soldotna	53,363,505	84,930,767	59.2%	31,567,262
Other KPB	176,944,646	193,977,222	9.6%	17,032,576
Total	375,140,887	521,606,851	39.0%	146,465,964

Table 1.8

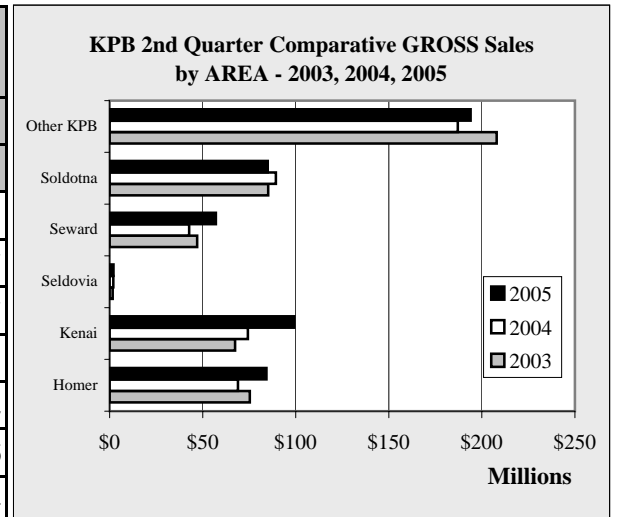

Chart 1.7

KPB 2nd Quarter GROSS Sales One Year Change by AREA - 2004-2005 - in \$				
			1 Year Change	
	2004	2005	Percentage	Numerical
Homer	68,978,475	84,293,052	22.2%	15,314,577
Kenai	74,275,624	99,203,608	33.6%	24,927,984
Seldovia	1,971,670	2,084,625	5.7%	112,955
Seward	42,760,800	57,117,577	33.6%	14,356,777
Soldotna	89,308,815	84,930,767	-4.9%	-4,378,048
Other KPB	187,093,229	193,977,222	3.7%	6,883,993
Total	464,388,613	521,606,851	12.3%	57,218,238

Table 1.9

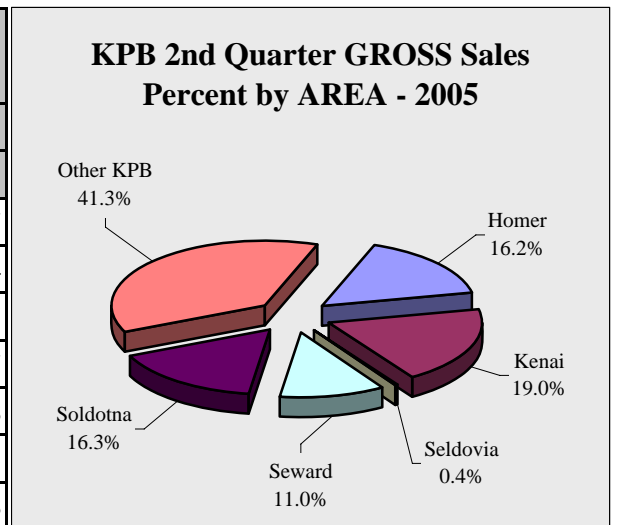

Chart 1.8

# KPB Sales

KPB 2nd Quarter TAXABLE Sales by AREA - 1999-2005 - in \$								
	1999	2000	2001	2002	2003	2004	2005	Annual Change
Homer	26,938,559	28,797,872	30,191,477	34,267,489	37,038,468	39,648,524	40,238,511	1.5%
Kenai	30,905,185	31,547,905	34,988,669	34,649,565	29,801,554	36,252,658	37,280,735	2.8%
Seldovia	915,962	1,018,255	956,033	898,830	962,966	939,589	926,708	-1.4%
Seward	19,907,186	21,160,898	21,553,264	22,176,474	22,072,081	22,997,045	25,039,952	8.9%
Soldotna	38,205,240	38,766,616	42,914,074	43,503,934	47,018,649	49,010,429	51,098,338	4.3%
Other KPB	50,746,526	55,205,057	57,871,082	57,360,509	58,170,580	58,187,673	60,105,978	3.3%
Total	167,618,658	176,496,603	188,474,599	192,856,801	195,064,298	207,035,918	214,690,222	3.7%
Annual Change		5.3%	6.8%	2.3%	1.1%	6.1%	3.7%	

Table 1.10

KPB 2nd Quarter TAXABLE Sales Ten Year Change by AREA - 1995-2005 - in \$				
			10 Year Change	
	1995	2005	Percentage	Numerical
Homer	24,901,076	40,238,511	61.6%	15,337,435
Kenai	28,333,677	37,280,735	31.6%	8,947,058
Seldovia	981,822	926,708	-5.6%	-55,114
Seward	16,721,903	25,039,952	49.7%	8,318,049
Soldotna	32,168,958	51,098,338	58.8%	18,929,380
Other KPB	44,648,194	60,105,978	34.6%	15,457,784
Total	147,755,630	214,690,222	45.3%	66,934,592

Table 1.11

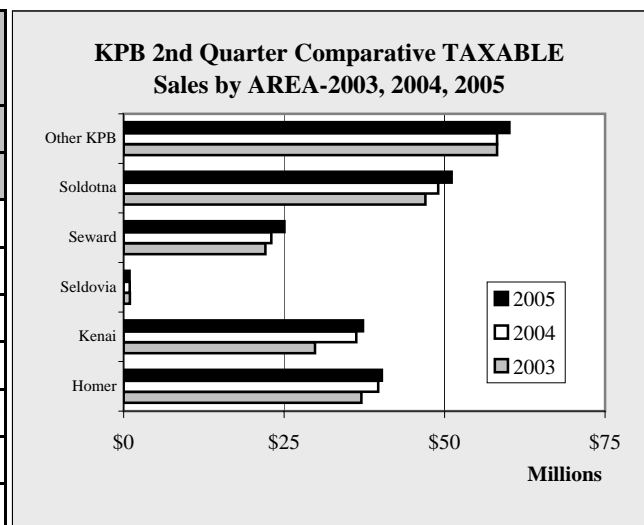

Chart 1.9

KPB 2nd Quarter TAXABLE Sales One Year Change by AREA - 2004-2005 - in \$				
			1 Year Change	
	2004	2005	Percentage	Numerical
Homer	39,648,524	40,238,511	1.5%	589,987
Kenai	36,252,658	37,280,735	2.8%	1,028,077
Seldovia	939,589	926,708	-1.4%	-12,881
Seward	22,997,045	25,039,952	8.9%	2,042,907
Soldotna	49,010,429	51,098,338	4.3%	2,087,909
Other KPB	58,187,673	60,105,978	3.3%	1,918,305
Total	207,035,918	214,690,222	3.7%	7,654,304

Table 1.12

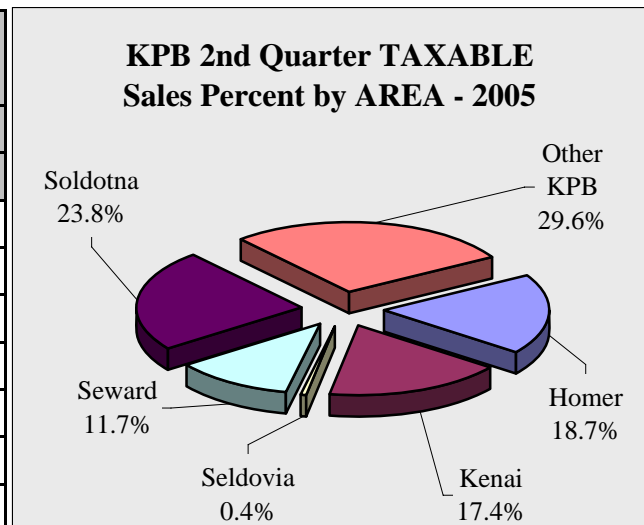

Chart 1.10

# KPB Sales

**KPB YTD 6/30 GROSS Sales by INDUSTRY - 1999-2005 - in \$**

	1999	2000	2001	2002	2003	2004	2005
Ag. Forestry, Fish	4,232,629	7,324,230	4,385,438	4,861,344	6,065,662	6,251,958	8,704,051
Mining	60,073,571	46,735,102	54,334,306	64,523,892	44,343,827	71,899,741	73,796,284
Construction	62,530,398	71,406,342	91,223,587	93,001,679	111,121,384	71,026,001	106,947,858
Manufacturing	64,380,550	59,515,301	105,149,536	66,005,209	72,836,195	41,647,284	53,664,885
Trans, Comm, Pub Util	79,777,691	73,792,185	78,569,430	83,101,571	77,059,039	74,385,678	124,677,770
Wholesale	69,463,920	77,663,421	80,077,933	83,667,742	86,760,176	92,413,286	72,567,868
Retail	243,879,541	256,797,055	283,285,514	281,185,083	293,832,344	314,556,550	329,788,507
Finance, Ins, Real Est	25,048,139	24,323,533	24,447,401	27,145,915	26,979,772	27,700,815	27,487,194
Services	94,089,544	100,079,432	106,708,416	120,655,660	119,202,254	125,361,273	127,422,071
Government	19,812	13,322	11,745	14,559	20,999	22,184	23,716
Total	703,495,795	717,649,923	828,193,306	824,162,654	838,221,652	825,264,770	925,080,204
Annual Change		2.0%	15.4%	-0.5%	1.7%	-1.5%	12.1%

Table 1.13

**KPB YTD 6/30 GROSS Sales Ten Year Change  
by INDUSTRY - 1995-2005 - in \$**

			10 Year Change	
	1995	2005	Percentage	Numerical
Ag. Forestry, Fish	28,398,555	8,704,051	-69.4%	-19,694,504
Mining	43,366,688	73,796,284	70.2%	30,429,596
Construction	55,679,743	106,947,858	92.1%	51,268,115
Manufacturing	70,268,931	53,664,885	-23.6%	-16,604,046
Trans, Comm, Pub Util	101,996,357	124,677,770	22.2%	22,681,413
Wholesale	54,698,925	72,567,868	32.7%	17,868,943
Retail	192,790,723	329,788,507	71.1%	136,997,784
Finance, Ins, Real Est	20,023,514	27,487,194	37.3%	7,463,680
Services	75,351,139	127,422,071	69.1%	52,070,932
Government	6,033	23,716	293.1%	17,683
Total	642,580,608	925,080,204	44.0%	282,499,596

Table 1.14

**KPB YTD 6/30 GROSS Sales by  
INDUSTRY - 2003, 2004, 2005**

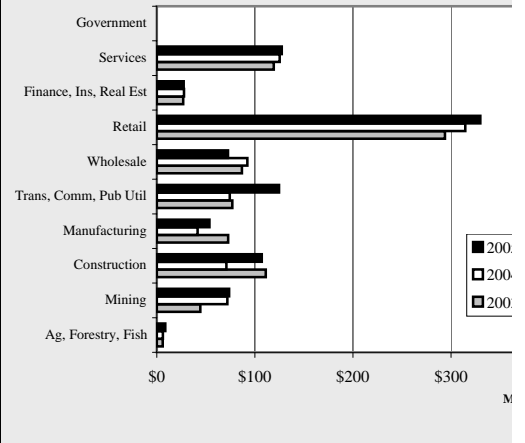

Chart 1.11

**KPB YTD 6/30 GROSS Sales One Year Change  
by INDUSTRY - 2004-2005 - in \$**

			1 Year Change	
	2004	2005	Percentage	Numerical
Ag. Forestry, Fish	6,251,958	8,704,051	39.2%	2,452,093
Mining	71,899,741	73,796,284	2.6%	1,896,543
Construction	71,026,001	106,947,858	50.6%	35,921,857
Manufacturing	41,647,284	53,664,885	28.9%	12,017,601
Trans, Comm, Pub Util	74,385,678	124,677,770	67.6%	50,292,092
Wholesale	92,413,286	72,567,868	-21.5%	-19,845,418
Retail	314,556,550	329,788,507	4.8%	15,231,957
Finance, Ins, Real Est	27,700,815	27,487,194	-0.8%	-213,621
Services	125,361,273	127,422,071	1.6%	2,060,798
Government	22,184	23,716	6.9%	1,532
Total	825,264,770	925,080,204	12.1%	99,815,434

Table 1.15

**KPB YTD 6/30 GROSS Sales  
Percent by INDUSTRY - 2005**

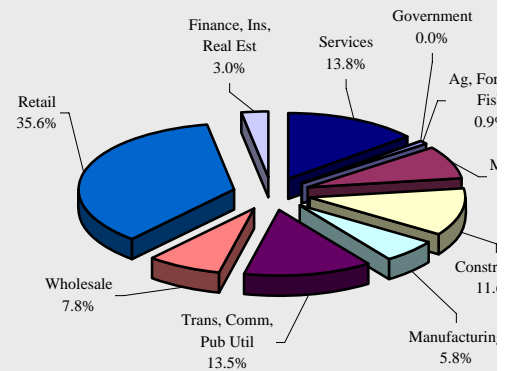
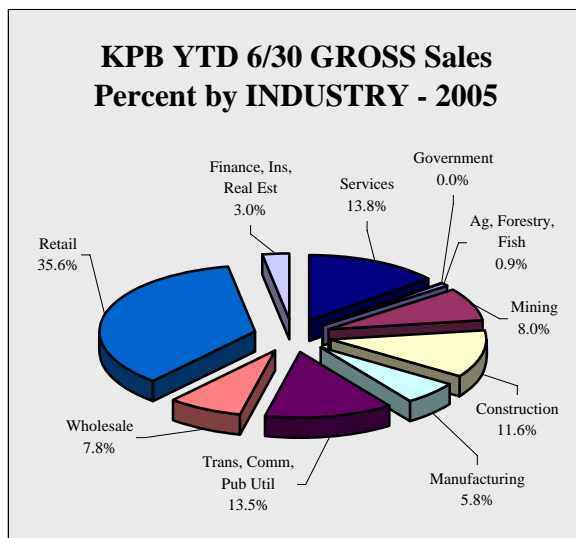
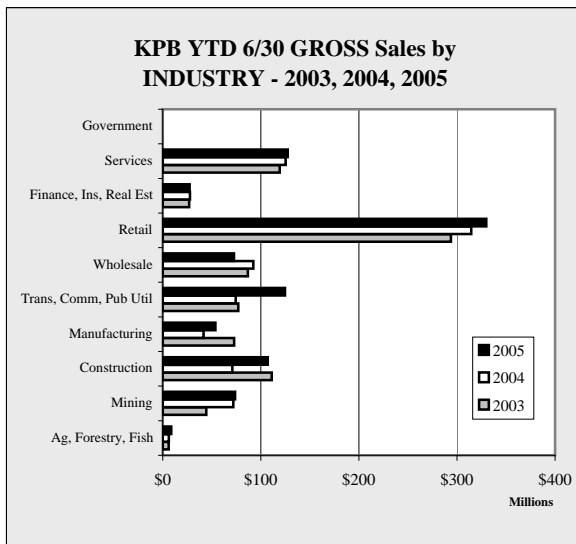

Chart 1.12

# KPB Sales

Annual Change
39.2%
2.6%
50.6%
28.9%
67.6%
-21.5%
4.8%
-0.8%
1.6%
6.9%
12.1%



# KPB Sales

KPB YTD 6/30 TAXABLE Sales by INDUSTRY - 1999-2005 - in \$								
	1999	2000	2001	2002	2003	2004	2005	Annual Change
Ag, Forest, Fishing	1,618,223	1,903,084	2,130,092	2,220,368	2,340,323	2,563,780	2,678,251	4.5%
Mining	1,701,296	1,987,867	2,577,296	2,966,852	2,404,111	2,130,172	2,115,004	-0.7%
Construction	4,372,902	4,353,592	4,393,270	4,714,971	5,188,611	5,139,211	5,115,231	-0.5%
Manufacturing	4,087,599	4,284,876	4,382,690	4,099,509	4,046,100	4,249,831	4,022,366	-5.4%
Trans, Comm, Pub Ut	38,030,469	38,357,947	38,384,906	43,051,137	41,971,663	40,495,467	43,036,143	6.3%
Wholesale	8,746,060	10,022,041	10,400,395	10,462,384	11,390,544	12,492,818	12,318,487	-1.4%
Retail	160,203,329	167,703,226	182,360,553	186,304,973	192,401,051	205,540,046	215,105,985	4.7%
Finance, Ins, Real Est	9,293,864	9,458,632	10,939,740	11,531,092	11,284,963	10,600,980	10,263,709	-3.2%
Services	53,943,980	56,565,623	58,753,041	60,292,562	60,298,460	63,695,410	64,286,395	0.9%
Government	19,812	13,322	11,745	14,559	20,999	22,119	23,716	7.2%
Total	282,017,534	294,650,210	314,333,728	325,658,407	331,346,825	346,929,834	358,965,287	3.5%
Annual Change		4.5%	6.7%	3.6%	1.7%	4.7%	3.5%	

Table 1.16

KPB YTD 6/30 TAXABLE Sales Ten Year Change by INDUSTRY - 1995-2005 - in \$				
			10 Year Change	
	1995	2005	Percentage	Numerical
Ag, Forest, Fishing	1,540,220	2,678,251	73.9%	1,138,031
Mining	2,058,119	2,115,004	2.8%	56,885
Construction	3,701,319	5,115,231	38.2%	1,413,912
Manufacturing	3,677,718	4,022,366	9.4%	344,648
Trans, Comm, Pub Ut	32,199,659	43,036,143	33.7%	10,836,484
Wholesale	9,724,367	12,318,487	26.7%	2,594,120
Retail	138,489,301	215,105,985	55.3%	76,616,684
Finance, Ins, Real Est	9,093,252	10,263,709	12.9%	1,170,457
Services	46,365,687	64,286,395	38.7%	17,920,708
Government	6,033	23,716	293.1%	17,683
Total	246,855,675	358,965,287	45.4%	112,109,612

Table 1.17

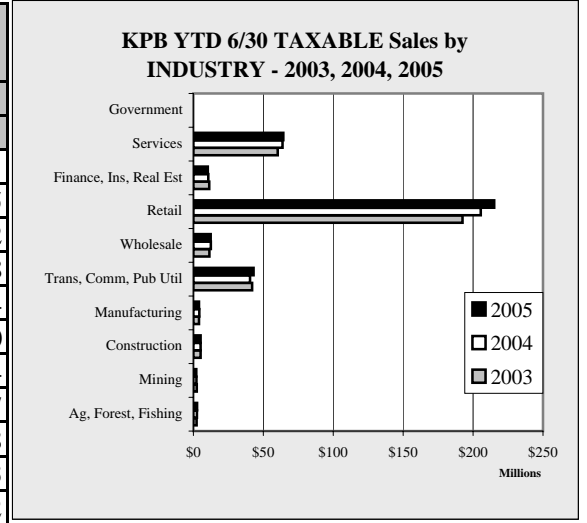

Chart 1.13

KPB YTD 6/30 TAXABLE Sales One Year Change by INDUSTRY - 2004-2005 - in \$				
			1 Year Change	
	2004	2005	Percentage	Numerical
Ag, Forest, Fishing	2,563,780	2,678,251	4.5%	114,471
Mining	2,130,172	2,115,004	-0.7%	-15,168
Construction	5,139,211	5,115,231	-0.5%	-23,980
Manufacturing	4,249,831	4,022,366	-5.4%	-227,465
Trans, Comm, Pub Ut	40,495,467	43,036,143	6.3%	2,540,676
Wholesale	12,492,818	12,318,487	-1.4%	-174,331
Retail	205,540,046	215,105,985	4.7%	9,565,939
Finance, Ins, Real Est	10,600,980	10,263,709	-3.2%	-337,271
Services	63,695,410	64,286,395	0.9%	590,985
Government	22,119	23,716	7.2%	1,597
Total	346,929,834	358,965,287	3.5%	12,035,453

Table 1.18

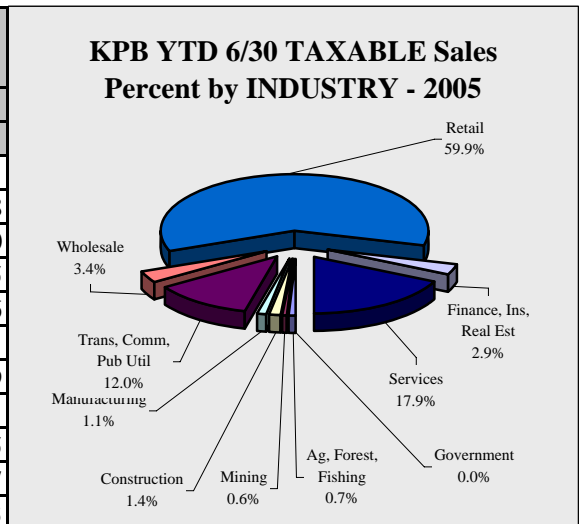

Chart 1.14

# KPB Sales

KPB YTD 6/30 GROSS Sales by AREA - 1999-2005 - in \$								
	1999	2000	2001	2002	2003	2004	2005	Annual Change
Homer	93,424,836	97,742,749	97,702,453	112,936,691	126,516,220	117,119,788	136,181,405	16.3%
Kenai	110,915,061	121,768,139	139,092,222	128,525,660	129,564,656	135,348,128	174,708,908	29.1%
Seldovia	2,296,246	2,677,592	2,372,116	2,166,767	2,476,460	3,376,717	3,345,692	-0.9%
Seward	59,398,212	57,101,834	64,983,550	63,339,389	67,919,337	63,936,089	83,576,862	30.7%
Soldotna	119,304,922	127,717,111	135,844,788	142,093,398	149,412,915	159,220,303	150,866,600	-5.2%
Other KPB	318,156,518	310,642,498	388,198,177	375,100,749	362,332,064	346,263,745	376,400,737	8.7%
Total	703,495,795	717,649,923	828,193,306	824,162,654	838,221,652	825,264,770	925,080,204	12.1%
Annual Change		2.0%	15.4%	-0.5%	1.7%	-1.5%	12.1%	

Table 1.19

KPB YTD 6/30 GROSS Sales Ten Year Change by AREA - 1995-2005 - in \$				
			10 Year Change	
	1995	2005	Percentage	Numerical
Homer	80,286,452	136,181,405	69.6%	55,894,953
Kenai	110,225,023	174,708,908	58.5%	64,483,885
Seldovia	2,765,473	3,345,692	21.0%	580,219
Seward	49,048,950	83,576,862	70.4%	34,527,912
Soldotna	93,990,552	150,866,600	60.5%	56,876,048
Other KPB	306,264,158	376,400,737	22.9%	70,136,579
Total	642,580,608	925,080,204	44.0%	282,499,596

Table 1.20

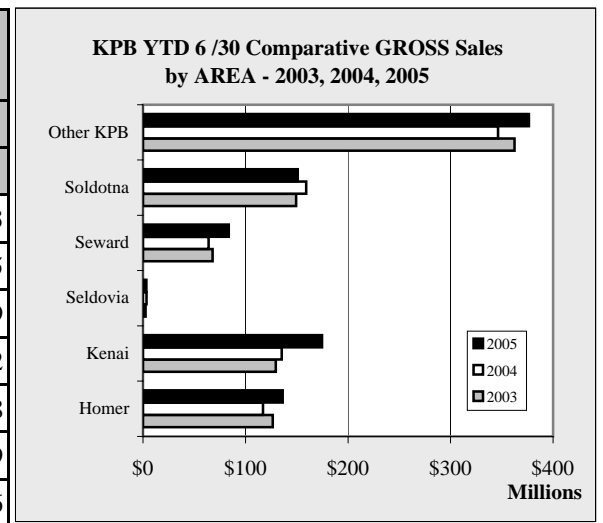

Chart 1.15

KPB YTD 6/30 GROSS Sales One Year Change by AREA - 2004-2005 - in \$				
			1 Year Change	
	2004	2005	Percentage	Numerical
Homer	117,119,788	136,181,405	16.3%	19,061,617
Kenai	135,348,128	174,708,908	29.1%	39,360,780
Seldovia	3,376,717	3,345,692	-0.9%	-31,025
Seward	63,936,089	83,576,862	30.7%	19,640,773
Soldotna	159,220,303	150,866,600	-5.2%	-8,353,703
Other KPB	346,263,745	376,400,737	8.7%	30,136,992
Total	825,264,770	925,080,204	12.1%	99,815,434

Table 1.21

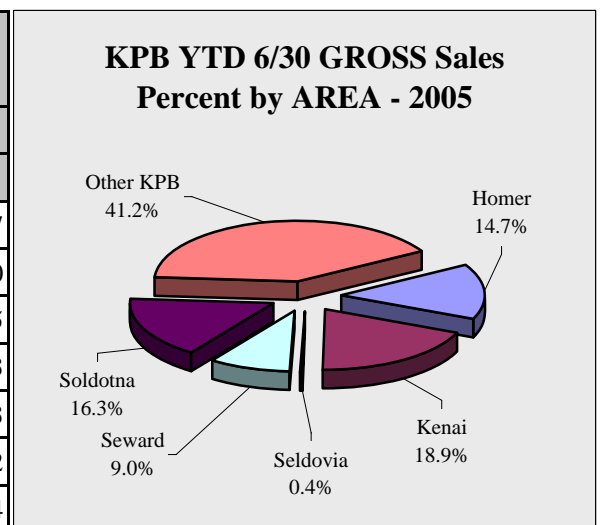

Chart 1.16

# KPB Sales

KPB YTD 6/30 TAXABLE Sales by AREA - 1999-2005 - in \$								
	1999	2000	2001	2002	2003	2004	2005	Annual Change
Homer	43,577,026	46,125,732	47,956,681	52,964,593	59,494,750	63,473,444	64,574,690	1.7%
Kenai	56,089,082	57,069,418	62,877,910	63,587,907	60,895,030	65,798,649	66,774,067	1.5%
Seldovia	1,485,400	1,587,348	1,539,588	1,472,454	1,561,936	1,506,315	1,499,225	-0.5%
Seward	29,125,864	30,535,258	30,626,757	31,227,518	31,356,585	32,491,809	35,131,352	8.1%
Soldotna	66,645,168	68,431,036	75,406,451	77,240,542	81,482,271	86,393,757	89,832,191	4.0%
Other KPB	85,094,994	90,901,418	95,926,341	99,165,393	96,556,253	97,268,860	101,153,762	4.0%
Total	282,017,534	294,650,210	314,333,728	325,658,407	331,346,825	346,932,834	358,965,287	3.5%
Annual Change		4.5%	6.7%	3.6%	1.7%	4.7%	3.5%	

Table 1.22

KPB YTD 6/30 TAXABLE Sales Ten Year Change by AREA - 1995-2005 - in \$				
			10 Year Change	
	1995	2005	Percentage	Numerical
Homer	39,698,606	64,574,690	62.7%	24,876,084
Kenai	51,145,431	66,774,067	30.6%	15,628,636
Seldovia	1,584,627	1,499,225	-5.4%	-85,402
Seward	24,395,915	35,131,352	44.0%	10,735,437
Soldotna	55,738,478	89,832,191	61.2%	34,093,713
Other KPB	74,292,618	101,153,762	36.2%	26,861,144
Total	246,855,675	358,965,287	45.4%	112,109,612

Table 1.23

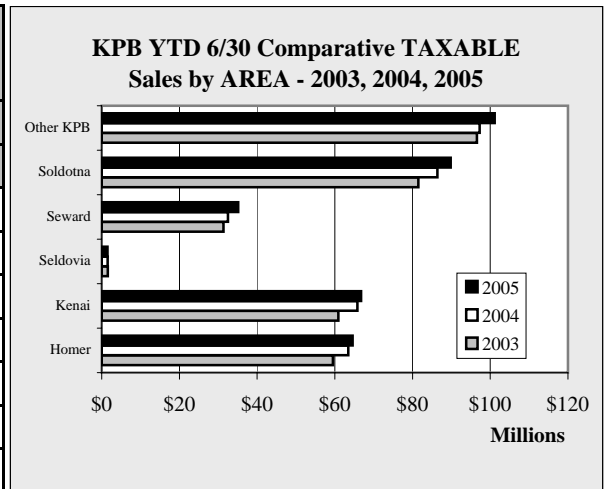

Chart 1.17

KPB YTD 6/30 TAXABLE Sales One Year Change by AREA - 2004-2005 - in \$				
			1 Year Change	
	2004	2005	Percentage	Numerical
Homer	63,473,444	64,574,690	1.7%	1,101,246
Kenai	65,798,649	66,774,067	1.5%	975,418
Seldovia	1,506,315	1,499,225	-0.5%	-7,090
Seward	32,491,809	35,131,352	8.1%	2,639,543
Soldotna	86,393,757	89,832,191	4.0%	3,438,434
Other KPB	97,268,860	101,153,762	4.0%	3,884,902
Total	346,932,834	358,965,287	3.5%	12,032,453

Table 1.24

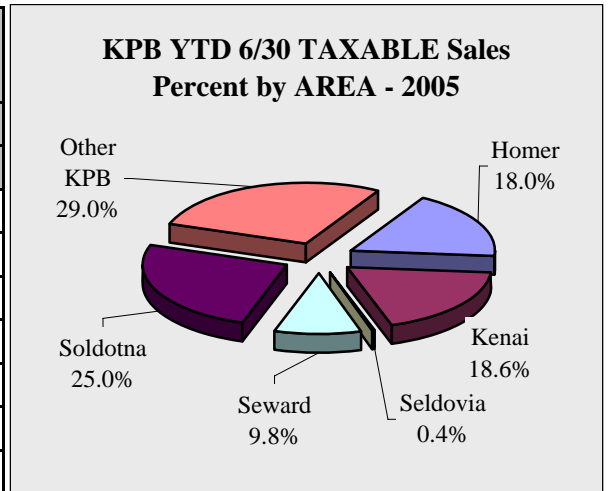

Chart 1.18

# KPB Sales

KPB Annual GROSS Sales by INDUSTRY - 1998-2004 - in \$								
	1998	1999	2000	2001	2002	2003	2004	Annual Change
Ag, Forest, Fish	30,373,442	32,347,943	24,816,872	17,584,763	16,750,059	22,009,310	27,631,235	25.5%
Mining	190,689,442	115,241,075	121,868,065	126,250,792	113,521,181	106,561,739	165,354,111	55.2%
Construction	187,102,648	166,008,223	185,994,582	241,706,588	229,399,098	258,447,580	237,489,930	-8.1%
Manufacturing	147,360,433	165,066,528	117,856,947	287,725,053	201,047,383	199,442,339	170,708,461	-14.4%
Trans, Comm, Pub Util	159,766,641	169,321,042	156,272,089	173,246,581	172,554,610	158,372,166	181,051,679	14.3%
Wholesale	149,117,372	155,121,630	171,235,874	177,036,125	188,223,387	194,212,922	366,603,918	88.8%
Retail	547,202,550	545,752,691	580,370,933	633,597,773	625,008,358	644,697,386	699,981,425	8.6%
Finance, Ins, Real Est	50,782,517	51,186,806	50,390,903	54,153,772	54,924,793	58,011,247	64,300,864	10.8%
Services	211,144,805	220,251,298	235,820,173	256,185,223	276,510,185	278,240,792	309,254,338	11.1%
Government	26,751	28,814	17,350	20,316	22,579	41,980	35,105	-16.4%
Total	1,673,566,601	1,620,326,050	1,644,643,788	1,967,506,986	1,877,961,633	1,920,037,461	2,222,411,066	15.7%
Annual Change		-3.2%	1.5%	19.6%	-4.6%	2.2%	15.7%	

Table 1.25

KPB Annual GROSS Sales Ten Year Change by INDUSTRY - 1994-2004 - in \$				
			10 Year Change	
	1994	2004	Percentage	Numerical
Ag, Forest, Fish	68,690,735	27,631,235	-59.8%	-41,059,500
Mining	122,926,355	165,354,111	34.5%	42,427,756
Construction	126,432,113	237,489,930	87.8%	111,057,817
Manufacturing	119,602,870	170,708,461	42.7%	51,105,591
Trans, Comm, Pub Util	215,875,618	181,051,679	-16.1%	-34,823,939
Wholesale	65,326,820	366,603,918	461.2%	301,277,098
Retail	375,876,957	699,981,425	86.2%	324,104,468
Finance, Ins, Real Est	47,089,458	64,300,864	36.6%	17,211,406
Services	149,140,054	309,254,338	107.4%	160,114,284
Government	8,126	35,105	332.0%	26,979
Total	1,290,969,106	2,222,411,066	72.2%	931,441,960

Table 1.26

KPB Annual GROSS Sales One Year Change by INDUSTRY - 2003-2004 - in \$				
			1 Year Change	
	2003	2004	Percentage	Numerical
Ag, Forest, Fish	22,009,310	27,631,235	25.5%	5,621,925
Mining	106,561,739	165,354,111	55.2%	58,792,372
Construction	258,447,580	237,489,930	-8.1%	-20,957,650
Manufacturing	199,442,339	170,708,461	-14.4%	-28,733,878
Trans, Comm, Pub Util	158,372,166	181,051,679	14.3%	22,679,513
Wholesale	194,212,922	366,603,918	88.8%	172,390,996
Retail	644,697,386	699,981,425	8.6%	55,284,039
Finance, Ins, Real Est	58,011,247	64,300,864	10.8%	6,289,617
Services	278,240,792	309,254,338	11.1%	31,013,546
Government	41,980	35,105	-16.4%	-6,875
Total	1,920,037,461	2,222,411,066	15.7%	302,373,605

Table 1.27

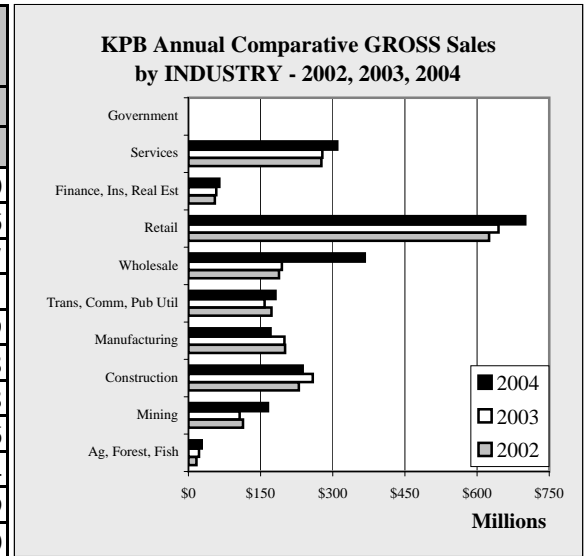

Chart 1.19

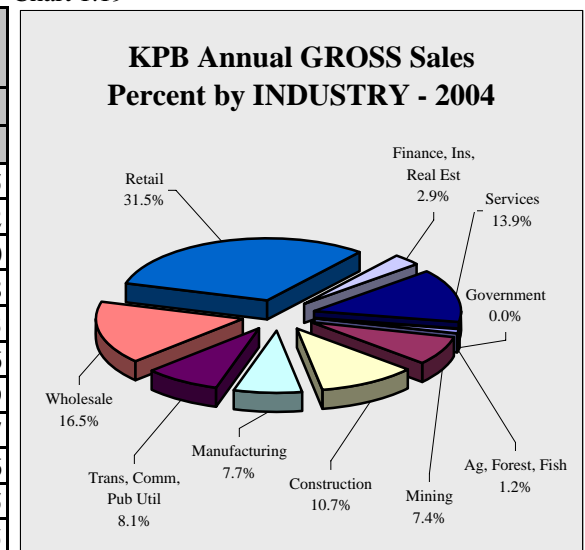

Chart 1.20



# KPB Sales

KPB Annual TAXABLE Sales by INDUSTRY - 1998-2004 - in \$								
	1998	1999	2000	2001	2002	2003	2004	Annual Change
AG, Forest, Fish	3,458,989	3,539,802	4,148,862	4,391,790	4,461,252	5,010,961	5,525,243	10.3%
Mining	5,202,698	3,828,650	4,613,878	5,863,223	5,848,904	4,885,262	5,502,300	12.6%
Construction	9,821,330	9,921,434	9,658,671	10,002,648	10,709,485	11,283,352	11,272,667	-0.1%
Manufacturing	9,578,020	9,251,298	9,792,611	9,654,663	9,616,559	9,239,486	9,859,946	6.7%
Trans, Comm, Pub Util	72,108,745	79,282,344	77,420,153	79,415,747	83,947,088	81,373,510	82,707,524	1.6%
Wholesale	18,357,305	19,290,256	21,493,691	22,282,063	21,690,782	24,282,313	26,290,768	8.3%
Retail	353,131,302	367,123,730	383,777,809	411,721,005	419,549,532	429,268,052	461,757,359	7.6%
Finance, Ins, Real Est	18,576,711	18,862,816	20,702,551	23,486,072	24,084,827	22,751,829	22,352,088	-1.8%
Services	122,225,757	129,434,976	135,510,623	139,066,219	144,301,953	144,745,238	154,901,038	7.0%
Government	26,744	28,814	17,350	20,316	22,579	41,980	35,040	-16.5%
Total	612,487,601	640,564,120	667,136,199	705,903,746	724,232,961	732,881,983	780,203,973	6.5%
Annual Change		4.6%	4.1%	5.8%	2.6%	1.2%	6.5%	

Table 1.28

KPB Annual TAXABLE Sales Ten Year Change by INDUSTRY - 1994-2004 - in \$				
			10 Year Change	
	1994	2004	Percentage	Numerical
AG, Forest, Fish	3,454,687	5,525,243	59.9%	2,070,556
Mining	6,132,287	5,502,300	-10.3%	-629,987
Construction	8,077,694	11,272,667	39.6%	3,194,973
Manufacturing	7,808,695	9,859,946	26.3%	2,051,251
Trans, Comm, Pub Util	64,017,267	82,707,524	29.2%	18,690,257
Wholesale	19,542,465	26,290,768	34.5%	6,748,303
Retail	299,416,591	461,757,359	54.2%	162,340,768
Finance, Ins, Real Est	18,378,264	22,352,088	21.6%	3,973,824
Services	100,262,803	154,901,038	54.5%	54,638,235
Government	10,251	35,040	241.8%	24,789
Total	527,101,004	780,203,973	48.0%	253,102,969

Table 1.29

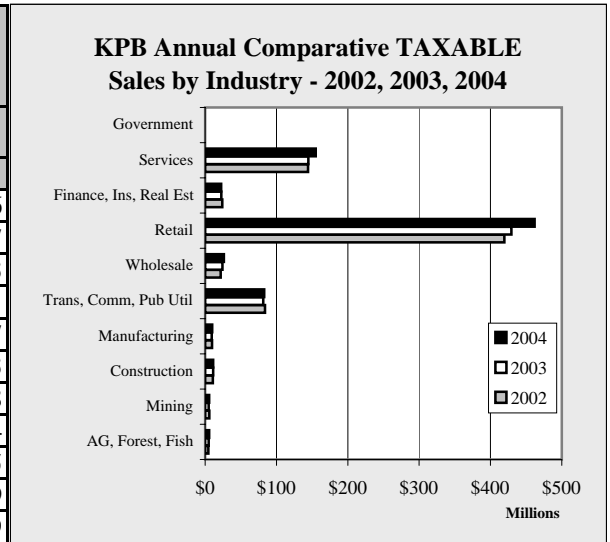

Chart 1.21

KPB Annual TAXABLE Sales One Year Change by INDUSTRY - 2003-2004 - in \$				
			1 Year Change	
	2003	2004	Percentage	Numerical
AG, Forest, Fish	5,010,961	5,525,243	10.3%	514,282
Mining	4,885,262	5,502,300	12.6%	617,038
Construction	11,283,352	11,272,667	-0.1%	-10,685
Manufacturing	9,239,486	9,859,946	6.7%	620,460
Trans, Comm, Pub Util	81,373,510	82,707,524	1.6%	1,334,014
Wholesale	24,282,313	26,290,768	8.3%	2,008,455
Retail	429,268,052	461,757,359	7.6%	32,489,307
Finance, Ins, Real Est	22,751,829	22,352,088	-1.8%	-399,741
Services	144,745,238	154,901,038	7.0%	10,155,800
Government	41,980	35,040	-16.5%	-6,940
Total	732,881,983	780,203,973	6.5%	47,321,990

Table 1.30

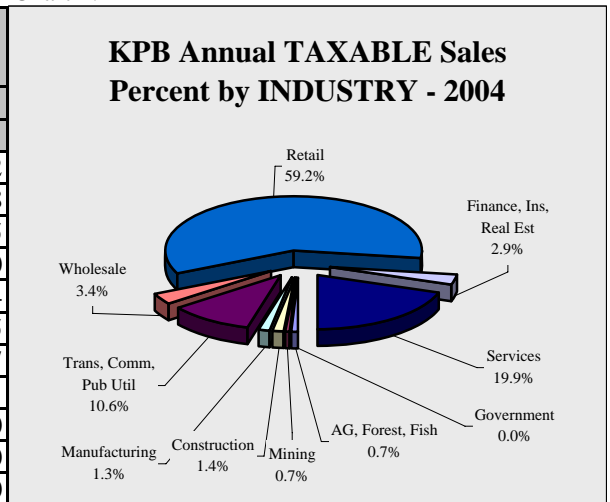

Chart 1.22

# KPB Sales

KPB Annual GROSS Sales by AREA - 1998-2004 - in \$								
	1998	1999	2000	2001	2002	2003	2004	Annual Change
Homer	212,442,617	203,842,475	215,981,724	229,703,507	263,195,800	274,030,866	283,682,519	3.5%
Kenai	280,079,940	270,746,118	283,682,464	310,426,425	279,745,403	283,340,242	469,314,722	65.6%
Seldovia	4,723,739	4,844,770	5,267,325	5,249,471	4,817,877	7,259,554	8,325,201	14.7%
Seward	132,506,248	130,155,521	142,152,279	148,360,553	142,367,126	156,961,522	166,213,217	5.9%
Soldotna	250,793,664	277,588,737	289,255,311	309,118,231	325,899,019	337,772,973	361,195,645	6.9%
KPB Other	793,020,393	733,148,429	708,304,685	964,648,799	861,936,408	860,672,304	933,679,762	8.5%
Total	1,673,566,601	1,620,326,050	1,644,643,788	1,967,506,986	1,877,961,633	1,920,037,461	2,222,411,066	15.7%
Annual Change		-3.2%	1.5%	19.6%	-4.6%	2.2%	15.7%	

Table 1.31

KPB Annual GROSS Sales Ten Year Change by AREA - 1994-2004 - in \$				
			10 Year Change	
	1994	2004	Percentage	Numerical
Homer	171,092,369	283,682,519	65.8%	112,590,150
Kenai	249,216,590	469,314,722	88.3%	220,098,132
Seldovia	5,275,307	8,325,201	57.8%	3,049,894
Seward	99,875,014	166,213,217	66.4%	66,338,203
Soldotna	194,609,544	361,195,645	85.6%	166,586,101
KPB Other	664,152,882	933,679,762	40.6%	269,526,880
Total	1,384,221,706	2,222,411,066	60.6%	838,189,360

Table 1.32

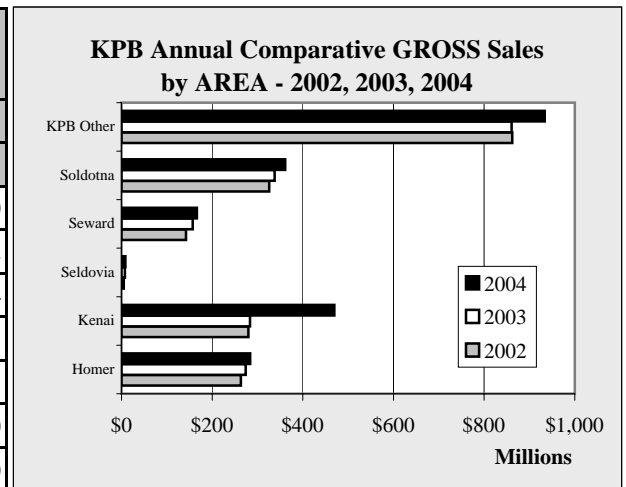

Chart 1.23

KPB Annual GROSS Sales One Year Change by AREA - 2003-2004 - in \$				
			1 Year Change	
	2003	2004	Percentage	Numerical
Homer	274,030,866	283,682,519	3.5%	9,651,653
Kenai	283,340,242	469,314,722	65.6%	185,974,480
Seldovia	7,259,554	8,325,201	14.7%	1,065,647
Seward	156,961,522	166,213,217	5.9%	9,251,695
Soldotna	337,772,973	361,195,645	6.9%	23,422,672
KPB Other	860,672,304	933,679,762	8.5%	73,007,458
Total	1,920,037,461	2,222,411,066	15.7%	302,373,605

Table 1.33

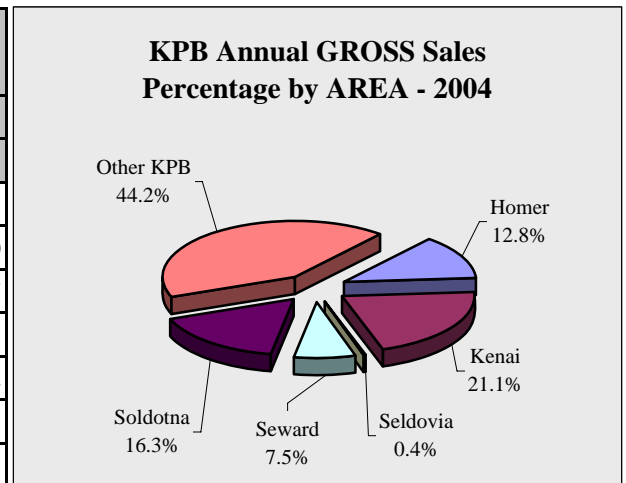

Chart 1.24

# KPB Sales

KPB Annual TAXABLE Sales by AREA - 1998-2004 - in \$								
	1998	1999	2000	2001	2002	2003	2004	Annual Change
Homer	94,441,342	98,148,738	103,190,116	107,311,539	121,268,118	131,688,838	140,002,852	6.3%
Kenai	120,030,707	124,367,091	127,766,126	137,043,924	136,769,610	121,312,219	138,630,979	14.3%
Seldovia	3,398,293	3,229,249	3,418,123	3,359,279	3,272,389	3,376,944	3,381,682	0.1%
Seward	67,278,264	71,472,199	73,983,426	74,225,591	75,598,696	76,348,269	79,945,206	4.7%
Soldotna	147,789,661	155,952,764	159,436,128	172,418,438	176,977,868	190,616,882	200,052,811	5.0%
KPB Other	179,549,334	187,394,079	199,342,280	211,544,975	210,346,280	209,538,831	218,190,443	4.1%
Total	612,487,601	640,564,120	667,136,199	705,903,746	724,232,961	732,881,983	780,203,973	6.5%
Annual Change		4.6%	4.1%	5.8%	2.6%	1.2%	6.5%	

Table 1.34

KPB Annual TAXABLE Sales Ten Year Change by AREA - 1994-2004 - in \$				
			10 Year Change	
	1994	2004	Percentage	Numerical
Homer	84,045,458	140,002,852	66.6%	55,957,394
Kenai	114,402,035	138,630,979	21.2%	24,228,944
Seldovia	3,117,185	3,381,682	8.5%	264,497
Seward	53,259,177	79,945,206	50.1%	26,686,029
Soldotna	119,702,481	200,052,811	67.1%	80,350,330
KPB Other	152,574,668	218,190,443	43.0%	65,615,775
Total	527,101,004	780,203,973	48.0%	253,102,969

Table 1.35

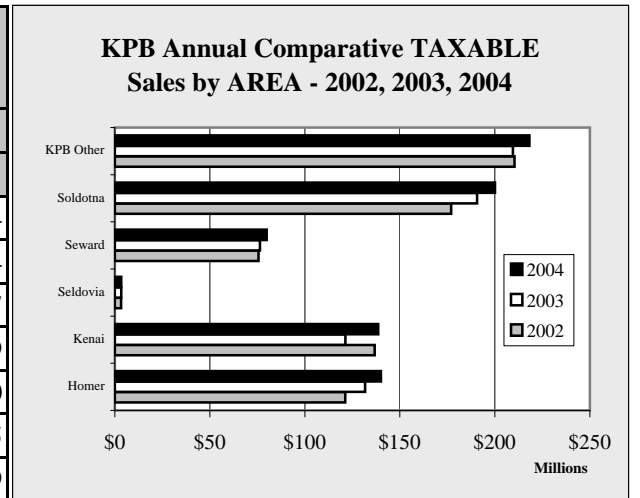

Chart 1.25

KPB Annual TAXABLE Sales One Year Change by AREA - 2003-2004 - in \$				
			1 Year Change	
	2003	2004	Percentage	Numerical
Homer	131,688,838	140,002,852	6.3%	8,314,014
Kenai	121,312,219	138,630,979	14.3%	17,318,760
Seldovia	3,376,944	3,381,682	0.1%	4,738
Seward	76,348,269	79,945,206	4.7%	3,596,937
Soldotna	190,616,882	200,052,811	5.0%	9,435,929
KPB Other	209,538,831	218,190,443	4.1%	8,651,612
Total	732,881,983	780,203,973	6.5%	47,321,990

Table 1.36

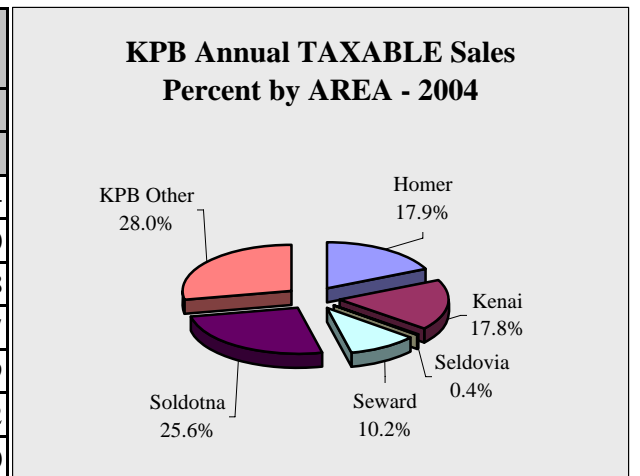

Chart 1.26

# KPB Sales

<b>KPB Annual GROSS Sales by INDUSTRY by Quarter - 2002-2005 - in \$</b>					
	1st Quarter	2nd Quarter	3rd Quarter	4th Quarter	Total
<b>2002</b>					
AG, Forestry, Fishing	2,004,841	2,856,503	9,835,705	2,053,010	16,750,059
Mining	34,662,385	29,861,507	26,316,221	22,681,068	113,521,181
Construction	43,149,133	49,852,546	72,113,003	64,284,416	229,399,098
Manufacturing	21,341,761	44,663,448	56,768,859	78,273,315	201,047,383
Trans, Comm, Pub Util	40,723,392	42,378,179	51,457,523	37,995,516	172,554,610
Wholesale	37,128,746	46,538,996	57,145,760	47,409,885	188,223,387
Retail	115,899,097	165,285,986	198,420,434	145,402,841	625,008,358
Finance, Ins, Real Est	12,389,238	14,756,677	15,233,449	12,545,429	54,924,793
Services	43,234,458	77,421,202	109,778,499	46,076,026	276,510,185
Government	6,700	7,859	4,290	3,730	22,579
<b>Total</b>	<b>350,539,751</b>	<b>473,622,903</b>	<b>597,073,743</b>	<b>456,725,236</b>	<b>1,877,961,633</b>
<b>2003</b>					
AG, Forestry, Fishing	2,019,939	4,045,723	13,491,140	2,452,508	22,009,310
Mining	19,260,142	25,083,685	30,366,980	31,850,932	106,561,739
Construction	43,362,431	67,758,953	81,935,651	65,390,545	258,447,580
Manufacturing	38,576,448	34,259,747	66,216,357	60,389,787	199,442,339
Trans, Comm, Pub Util	38,217,073	38,841,966	43,819,198	37,493,929	158,372,166
Wholesale	35,918,425	50,841,751	60,869,241	46,583,505	194,212,922
Retail	123,120,433	170,711,911	201,816,813	149,048,229	644,697,386
Finance, Ins, Real Est	11,704,586	15,275,186	16,074,854	14,956,621	58,011,247
Services	41,556,541	77,645,713	108,482,303	50,556,235	278,240,792
Government	12,319	8,680	12,192	8,789	41,980
<b>Total</b>	<b>353,748,337</b>	<b>484,473,315</b>	<b>623,084,729</b>	<b>458,731,080</b>	<b>1,920,037,461</b>
<b>2004</b>					
AG, Forestry, Fishing	2,340,926	3,911,032	15,695,017	5,684,260	27,631,235
Mining	39,801,394	32,098,347	39,000,757	54,453,613	165,354,111
Construction	28,642,511	42,383,490	67,076,779	99,387,150	237,489,930
Manufacturing	26,107,055	15,540,229	97,207,179	31,853,998	170,708,461
Trans, Comm, Pub Util	38,967,049	35,418,629	55,432,460	51,233,541	181,051,679
Wholesale	41,782,771	50,630,515	55,365,704	218,824,928	366,603,918
Retail	126,840,495	187,716,055	224,549,230	160,875,645	699,981,425
Finance, Ins, Real Est	13,300,910	14,399,905	16,956,561	19,643,488	64,300,864
Services	43,079,383	82,281,890	120,011,966	63,881,099	309,254,338
Government	13,663	8,521	9,184	3,737	35,105
<b>Total</b>	<b>360,876,157</b>	<b>464,388,613</b>	<b>691,304,837</b>	<b>705,841,459</b>	<b>2,222,411,066</b>
<b>2005</b>					
					<b>Year to Date</b>
AG, Forestry, Fishing	2,974,036	5,730,015			8,704,051
Mining	39,831,609	33,964,675			73,796,284
Construction	42,300,507	64,647,351			106,947,858
Manufacturing	33,842,096	19,822,789			53,664,885
Trans, Comm, Pub Util	58,385,026	66,292,744			124,677,770
Wholesale	37,234,787	35,333,081			72,567,868
Retail	131,203,707	198,584,800			329,788,507
Finance, Ins, Real Est	11,873,634	15,613,560			27,487,194
Services	45,812,737	81,609,334			127,422,071
Government	15,214	8,502			23,716
<b>Total</b>	<b>403,473,353</b>	<b>521,606,851</b>	<b>0</b>	<b>0</b>	<b>925,080,204</b>

Table 1.37

# KPB Sales

<b>KPB Annual TAXABLE Sales by INDUSTRY by Quarter - 2002-2005 - in \$</b>					
	1st Quarter	2nd Quarter	3rd Quarter	4th Quarter	Total
<b>2002</b>					
AG, Forestry, Fishing	796,380	1,423,988	1,400,008	840,876	4,461,252
Mining	1,482,601	1,484,251	1,550,583	1,331,469	5,848,904
Construction	2,037,148	2,677,823	3,288,688	2,705,826	10,709,485
Manufacturing	1,307,744	2,791,765	3,717,020	1,800,030	9,616,559
Trans, Comm, Pub Util	21,573,935	21,477,202	21,106,028	19,789,923	83,947,088
Wholesale	4,783,261	5,679,123	6,316,722	4,911,676	21,690,782
Retail	76,421,463	109,883,510	136,536,484	96,708,075	419,549,532
Finance, Ins, Real Est	5,453,086	6,078,006	6,917,181	5,636,554	24,084,827
Services	18,939,288	41,353,274	62,644,991	21,364,400	144,301,953
Government	6,700	7,859	4,290	3,730	22,579
<b>Total</b>	<b>132,801,606</b>	<b>192,856,801</b>	<b>243,481,995</b>	<b>155,092,559</b>	<b>724,232,961</b>
<b>2003</b>					
AG, Forestry, Fishing	763,045	1,577,278	1,697,754	972,884	5,010,961
Mining	1,233,618	1,170,493	1,313,871	1,167,280	4,885,262
Construction	2,059,743	3,128,868	3,321,173	2,773,568	11,283,352
Manufacturing	1,438,887	2,607,213	3,333,206	1,860,180	9,239,486
Trans, Comm, Pub Util	21,650,525	20,321,138	19,718,329	19,683,518	81,373,510
Wholesale	5,052,561	6,337,983	7,103,240	5,788,529	24,282,313
Retail	79,983,487	112,417,564	139,063,076	97,803,925	429,268,052
Finance, Ins, Real Est	5,309,694	5,975,269	6,458,624	5,008,242	22,751,829
Services	18,778,648	41,519,812	62,826,465	21,620,313	144,745,238
Government	12,319	8,680	12,192	8,789	41,980
<b>Total</b>	<b>136,282,527</b>	<b>195,064,298</b>	<b>244,847,930</b>	<b>156,687,228</b>	<b>732,881,983</b>
<b>2004</b>					
AG, Forestry, Fishing	889,277	1,674,503	1,979,566	981,897	5,525,243
Mining	1,047,668	1,082,504	1,908,215	1,463,913	5,502,300
Construction	2,217,009	2,922,202	3,280,174	2,853,282	11,272,667
Manufacturing	1,512,130	2,737,701	3,843,780	1,766,335	9,859,946
Trans, Comm, Pub Util	21,021,541	19,473,926	21,221,357	20,990,700	82,707,524
Wholesale	5,892,430	6,600,388	7,644,161	6,153,789	26,290,768
Retail	83,160,577	122,379,469	153,420,901	102,796,412	461,757,359
Finance, Ins, Real Est	4,888,930	5,712,050	6,620,451	5,130,657	22,352,088
Services	19,251,756	44,443,654	69,141,627	22,064,001	154,901,038
Government	13,598	8,521	9,184	3,737	35,040
<b>Total</b>	<b>139,894,916</b>	<b>207,034,918</b>	<b>269,069,416</b>	<b>164,204,723</b>	<b>780,203,973</b>
<b>2005</b>					
					<b>Year to Date</b>
AG, Forestry, Fishing	947,666	1,730,585			2,678,251
Mining	1,087,830	1,027,174			2,115,004
Construction	2,086,621	3,028,610			5,115,231
Manufacturing	1,344,743	2,677,623			4,022,366
Trans, Comm, Pub Util	23,080,328	19,955,815			43,036,143
Wholesale	5,623,554	6,694,933			12,318,487
Retail	85,817,848	129,288,137			215,105,985
Finance, Ins, Real Est	4,678,256	5,585,453			10,263,709
Services	19,593,005	44,693,390			64,286,395
Government	15,214	8,502			23,716
<b>Total</b>	<b>144,275,065</b>	<b>214,690,222</b>	<b>0</b>	<b>0</b>	<b>358,965,287</b>

Table 1.38

# KPB Sales

<b>KPB Annual GROSS Sales by AREA by Quarter - 2000-2005 - in \$</b>					
	1st Qtr	2nd Qtr	3rd Qtr	4th Qtr	Total
<b>2000</b>					
Homer	38,455,167	59,287,582	70,009,668	48,229,307	215,981,724
Kenai	55,609,576	66,158,563	89,505,566	72,408,759	283,682,464
Seldovia	1,150,692	1,526,900	1,693,636	896,097	5,267,325
Seward	19,087,797	38,014,037	57,260,079	27,790,366	142,152,279
Soldotna	55,201,896	72,515,215	89,530,301	72,007,899	289,255,311
Other KPB	126,664,981	183,977,517	225,474,396	172,187,791	708,304,685
<b>Total</b>	<b>296,170,109</b>	<b>421,479,814</b>	<b>533,473,646</b>	<b>393,520,219</b>	<b>1,644,643,788</b>
<b>2001</b>					
Homer	40,844,978	56,857,475	77,453,956	54,547,098	229,703,507
Kenai	62,418,286	76,673,936	94,911,501	76,422,702	310,426,425
Seldovia	898,811	1,473,305	1,957,554	919,801	5,249,471
Seward	20,531,272	44,452,278	62,873,649	20,503,354	148,360,553
Soldotna	60,802,277	75,042,511	95,670,432	77,603,011	309,118,231
Other KPB	170,550,210	217,647,967	286,388,798	290,061,824	964,648,799
<b>Total</b>	<b>356,045,834</b>	<b>472,147,472</b>	<b>619,255,890</b>	<b>520,057,790</b>	<b>1,967,506,986</b>
<b>2002</b>					
Homer	44,264,946	68,671,745	89,690,601	60,568,508	263,195,800
Kenai	60,596,369	67,929,291	82,601,639	68,618,104	279,745,403
Soldotna	1,011,712	1,155,055	1,694,174	956,936	4,817,877
Seward	22,954,013	40,385,376	56,721,649	22,306,088	142,367,126
Soldotna	62,331,750	79,761,648	103,624,839	80,180,782	325,899,019
Other KPB	159,380,961	215,719,788	262,740,841	224,094,818	861,936,408
<b>Total</b>	<b>350,539,751</b>	<b>473,622,903</b>	<b>597,073,743</b>	<b>456,725,236</b>	<b>1,877,961,633</b>
<b>2003</b>					
Homer	51,228,276	75,287,944	87,188,300	60,326,346	274,030,866
Kenai	62,140,357	67,424,299	81,229,776	72,545,810	283,340,242
Seldovia	847,005	1,629,455	2,833,785	1,949,309	7,259,554
Seward	20,935,184	46,984,153	61,707,771	27,334,414	156,961,522
Soldotna	64,233,718	85,179,197	106,204,940	82,155,118	337,772,973
Other KPB	154,363,797	207,968,267	283,920,157	214,420,083	860,672,304
<b>Total</b>	<b>353,748,337</b>	<b>484,473,315</b>	<b>623,084,729</b>	<b>458,731,080</b>	<b>1,920,037,461</b>
<b>2004</b>					
Homer	48,141,313	68,978,475	93,936,080	72,626,651	283,682,519
Kenai	61,072,504	74,275,624	97,847,270	236,119,324	469,314,722
Seldovia	1,405,047	1,971,670	1,809,067	3,139,417	8,325,201
Seward	21,175,289	42,760,800	63,926,605	38,350,523	166,213,217
Soldotna	69,911,488	89,308,815	107,188,196	94,787,146	361,195,645
Other KPB	159,170,516	187,093,229	326,597,619	260,818,398	933,679,762
<b>Total</b>	<b>360,876,157</b>	<b>464,388,613</b>	<b>691,304,837</b>	<b>705,841,459</b>	<b>2,222,411,066</b>
<b>2005</b>					
					<b>Year to Date</b>
Homer	51,888,353	84,293,052			136,181,405
Kenai	75,505,300	99,203,608			174,708,908
Seldovia	1,261,067	2,084,625			3,345,692
Seward	26,459,285	57,117,577			83,576,862
Soldotna	65,935,833	84,930,767			150,866,600
Other KPB	182,423,515	193,977,222			376,400,737
<b>Total</b>	<b>403,473,353</b>	<b>521,606,851</b>	<b>0</b>	<b>0</b>	<b>925,080,204</b>

Table 1.39

# KPB Sales

<b>KPB Annual TAXABLE Sales by AREA by Quarter - 2000-2005 - in \$</b>					
	1st Qtr	2nd Qtr	3rd Qtr	4th Qtr	Total
<b>2000</b>					
Homer	17,327,860	28,797,872	35,677,211	21,387,173	103,190,116
Kenai	25,521,513	31,547,905	36,634,363	34,062,345	127,766,126
Seldovia	569,093	1,018,255	1,241,108	589,667	3,418,123
Seward	9,374,360	21,160,898	32,903,473	10,544,695	73,983,426
Soldotna	29,664,420	38,766,616	50,523,183	40,481,909	159,436,128
Other KPB	35,696,361	55,205,057	66,472,925	41,967,937	199,342,280
<b>Total</b>	<b>118,153,607</b>	<b>176,496,603</b>	<b>223,452,263</b>	<b>149,033,726</b>	<b>667,136,199</b>
<b>2001</b>					
Homer	17,765,204	30,191,477	37,574,702	21,780,156	107,311,539
Kenai	27,889,241	34,988,669	38,162,815	36,003,199	137,043,924
Seldovia	583,555	956,033	1,207,525	612,166	3,359,279
Seward	9,073,493	21,553,264	33,591,333	10,007,501	74,225,591
Soldotna	32,492,377	42,914,074	54,143,248	42,868,739	172,418,438
Other KPB	38,055,259	57,871,082	68,857,364	46,761,270	211,544,975
<b>Total</b>	<b>125,859,129</b>	<b>188,474,599</b>	<b>233,536,987</b>	<b>158,033,031</b>	<b>705,903,746</b>
<b>2002</b>					
Homer	18,697,104	34,267,489	43,251,111	25,052,414	121,268,118
Kenai	28,938,342	34,649,565	38,192,980	34,988,723	136,769,610
Soldotna	573,624	898,830	1,191,989	607,946	3,272,389
Seward	9,051,044	22,176,474	34,338,060	10,033,118	75,598,696
Soldotna	33,736,608	43,503,934	57,488,623	42,248,703	176,977,868
Other KPB	41,804,884	57,360,509	69,019,232	42,161,655	210,346,280
<b>Total</b>	<b>132,801,606</b>	<b>192,856,801</b>	<b>243,481,995</b>	<b>155,092,559</b>	<b>724,232,961</b>
<b>2003</b>					
Homer	22,456,282	37,038,468	45,088,541	27,105,547	131,688,838
Kenai	31,093,476	29,801,554	31,351,738	29,065,451	121,312,219
Seldovia	598,970	962,966	1,140,319	674,689	3,376,944
Seward	9,284,504	22,072,081	34,702,382	10,289,302	76,348,269
Soldotna	34,463,622	47,018,649	62,576,271	46,558,340	190,616,882
Other KPB	38,385,673	58,170,580	69,988,679	42,993,899	209,538,831
<b>Total</b>	<b>136,282,527</b>	<b>195,064,298</b>	<b>244,847,930</b>	<b>156,687,228</b>	<b>732,881,983</b>
<b>2004</b>					
Homer	23,824,920	39,648,524	49,028,169	27,501,239	140,002,852
Kenai	29,545,991	36,252,658	40,030,825	32,801,505	138,630,979
Seldovia	566,726	939,589	1,182,138	693,229	3,381,682
Seward	9,494,764	22,997,045	37,077,424	10,375,973	79,945,206
Soldotna	37,383,328	49,010,429	66,182,951	47,476,103	200,052,811
Other KPB	39,081,187	58,187,673	75,567,409	45,354,174	218,190,443
<b>Total</b>	<b>139,896,916</b>	<b>207,035,918</b>	<b>269,068,916</b>	<b>164,202,223</b>	<b>780,203,973</b>
<b>2005</b>					
Homer	24,336,179	40,238,511			64,574,690
Kenai	29,493,332	37,280,735			66,774,067
Seldovia	572,517	926,708			1,499,225
Seward	10,091,400	25,039,952			35,131,352
Soldotna	38,733,853	51,098,338			89,832,191
Other KPB	41,047,784	60,105,978			101,153,762
<b>Total</b>	<b>144,275,065</b>	<b>214,690,222</b>	<b>0</b>	<b>0</b>	<b>358,965,287</b>

Table 1.40

# KPB Construction

<b>KPB 2nd Quarter Permit VALUES by AREA - 1999-2005 - in \$</b>								
	1999	2000	2001	2002	2003	2004	2005	Annual Change
Homer	2,691,000	2,265,920	4,102,040	2,528,209	7,929,500	7,433,711	11,242,000	51.2%
Kenai	2,022,600	3,163,000	7,597,900	4,569,400	2,728,350	1,897,400	2,557,300	34.8%
Seldovia	365,500	22,300	25,000	8,000	0	156,200	466,000	198.3%
Seward	1,082,114	1,765,400	666,239	3,888,887	3,672,010	7,443,900	669,540	-91.0%
Soldotna	4,785,052	4,009,356	3,231,190	7,003,458	4,233,924	3,748,573	6,832,235	82.3%
<b>Total</b>	<b>10,946,266</b>	<b>11,225,976</b>	<b>15,622,369</b>	<b>17,997,954</b>	<b>18,563,784</b>	<b>20,679,784</b>	<b>21,767,075</b>	<b>5.3%</b>
<b>Annual Change</b>		<b>2.6%</b>	<b>39.2%</b>	<b>15.2%</b>	<b>3.1%</b>	<b>11.4%</b>	<b>5.3%</b>	

Table 1.41

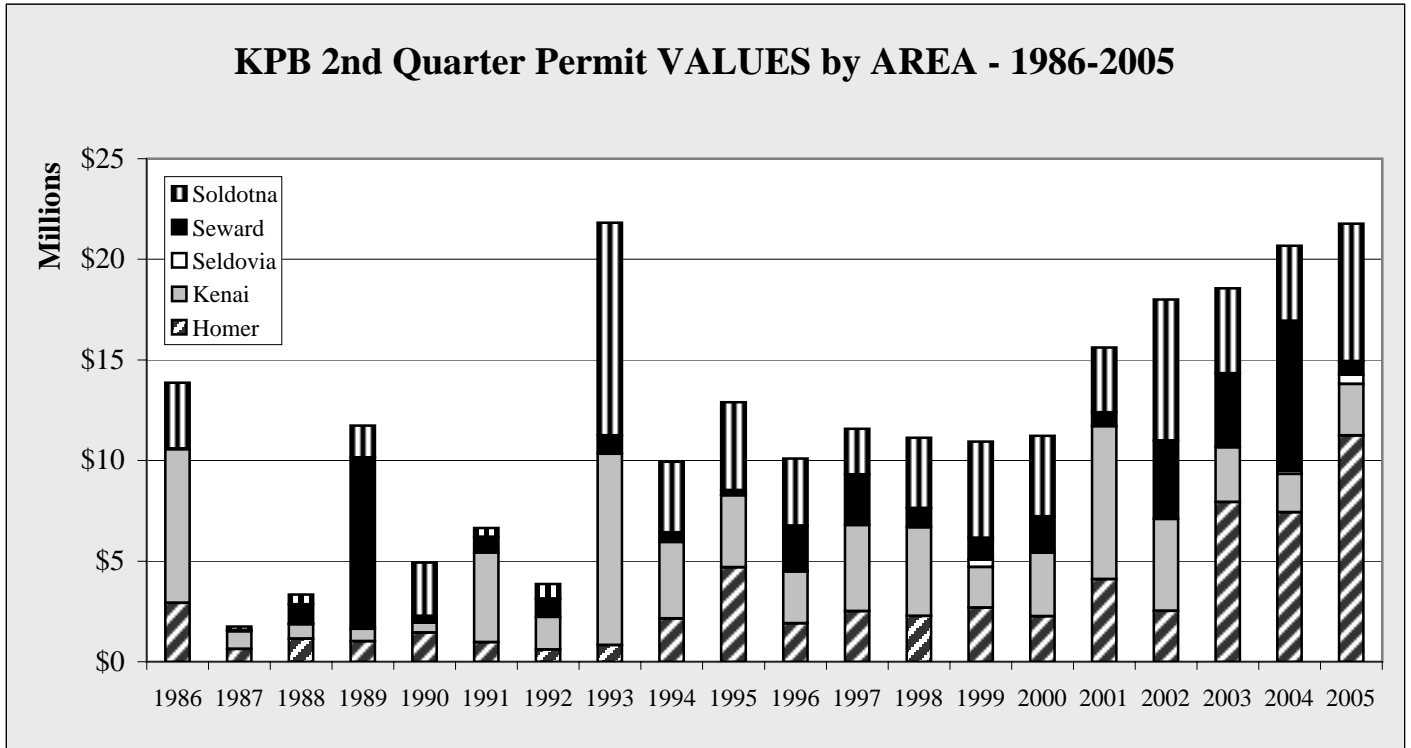

Chart 1.27

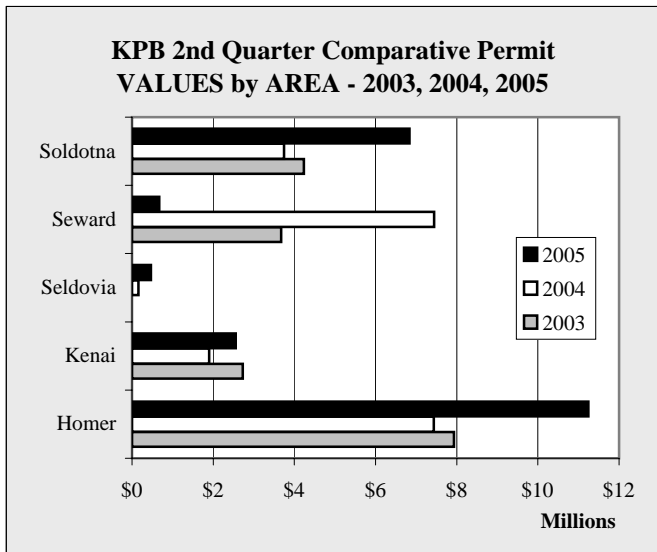

Chart 1.28

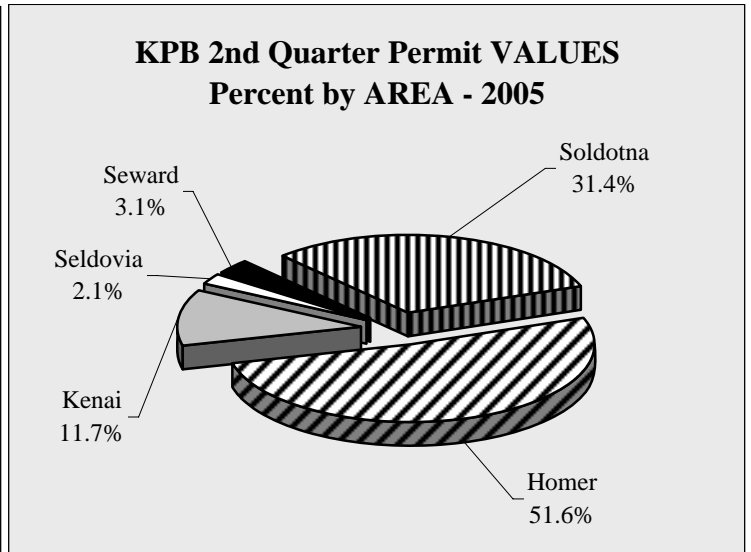

Chart 1.29



# KPB Construction

**KPB 2nd Quarter Permit VOLUME by AREA - 1999-2005**

	1999	2000	2001	2002	2003	2004	2005	Annual Change
Homer	21	20	34	17	34	26	46	76.9%
Kenai	33	36	42	37	40	30	33	10.0%
Seldovia	9	3	1	2	0	3	6	100.0%
Seward	18	20	14	29	13	21	21	0.0%
Soldotna	35	34	37	51	36	26	40	53.8%
<b>Total</b>	<b>116</b>	<b>113</b>	<b>128</b>	<b>136</b>	<b>123</b>	<b>106</b>	<b>146</b>	<b>37.7%</b>
Annual Change		-2.6%	13.3%	6.3%	-9.6%	-13.8%	37.7%	

Table 1.42

**KPB 2nd Quarter Permit VOLUME by AREA - 1986-2005**

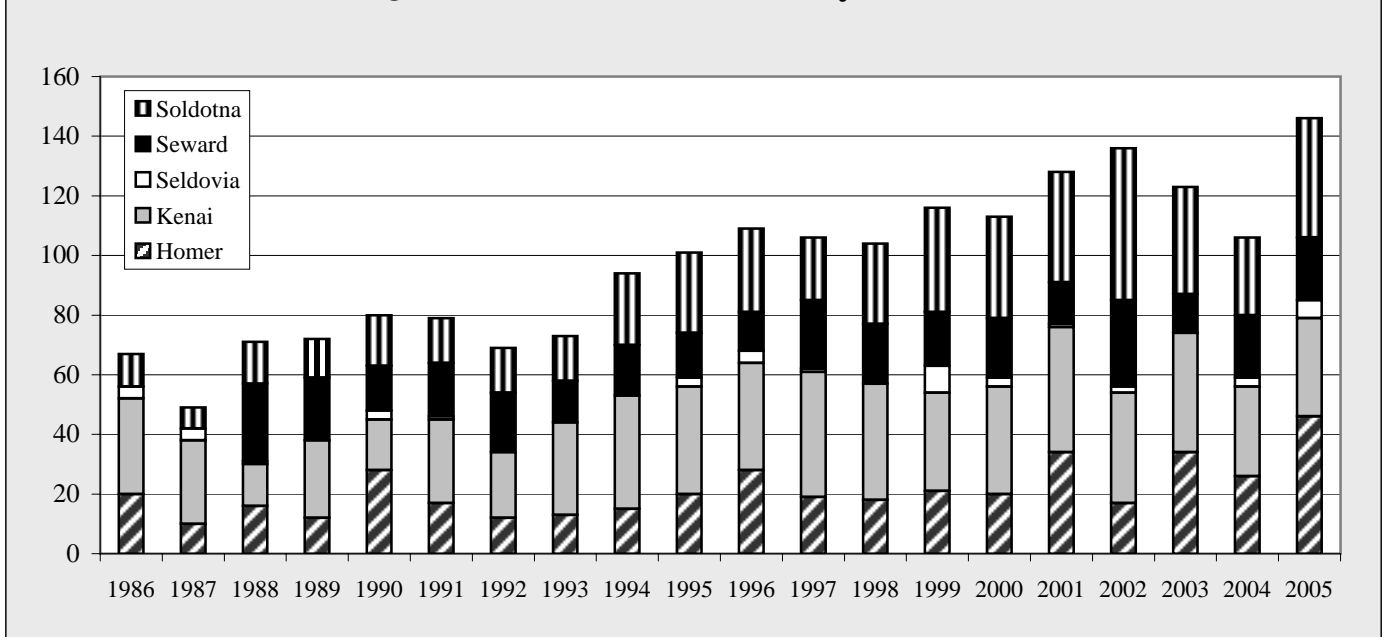

Chart 1.30

**KPB 2nd Quarter Comparative VOLUME by AREA - 2003, 2004, 2005**

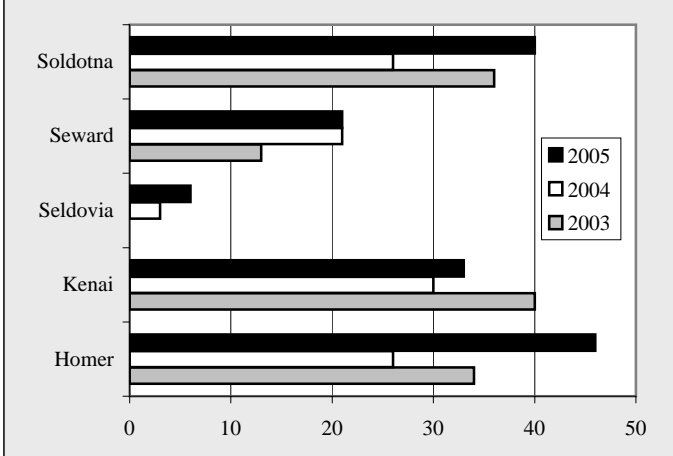

Chart 1.31

**KPB 2nd Quarter Permit VOLUME Percent by AREA - 2005**

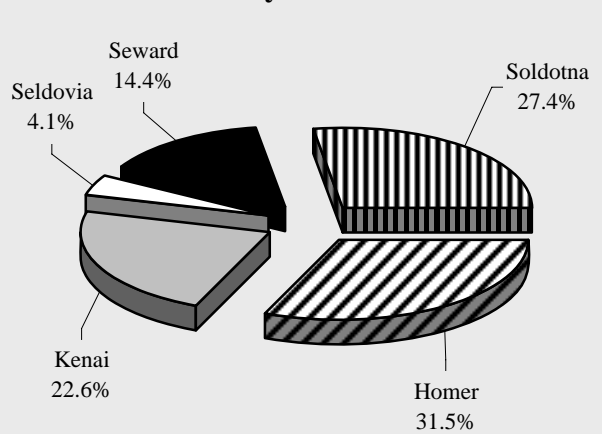

Chart 1.32

# KPB Construction

<b>KPB 2nd Quarter Permit VALUES by TYPE - 1999-2005 - in \$</b>								
	1999	2000	2001	2002	2003	2004	2005	Annual Change
New Residential	4,754,674	4,531,931	7,367,801	6,145,753	7,868,834	6,374,487	7,560,499	18.6%
Residential Alter/Add	667,961	860,574	758,779	1,044,943	984,340	483,839	833,770	72.3%
New Commercial	4,798,818	3,564,122	5,384,800	8,376,305	8,965,210	11,147,815	11,692,848	4.9%
Commercial Alter/Add	724,813	2,269,349	2,110,989	2,430,953	745,400	2,673,643	1,679,958	-37.2%
<b>Total</b>	<b>10,946,266</b>	<b>11,225,976</b>	<b>15,622,369</b>	<b>17,997,954</b>	<b>18,563,784</b>	<b>20,679,784</b>	<b>21,767,075</b>	<b>5.3%</b>
Annual Change		2.6%	39.2%	15.2%	3.1%	11.4%	5.3%	

Table 1.43

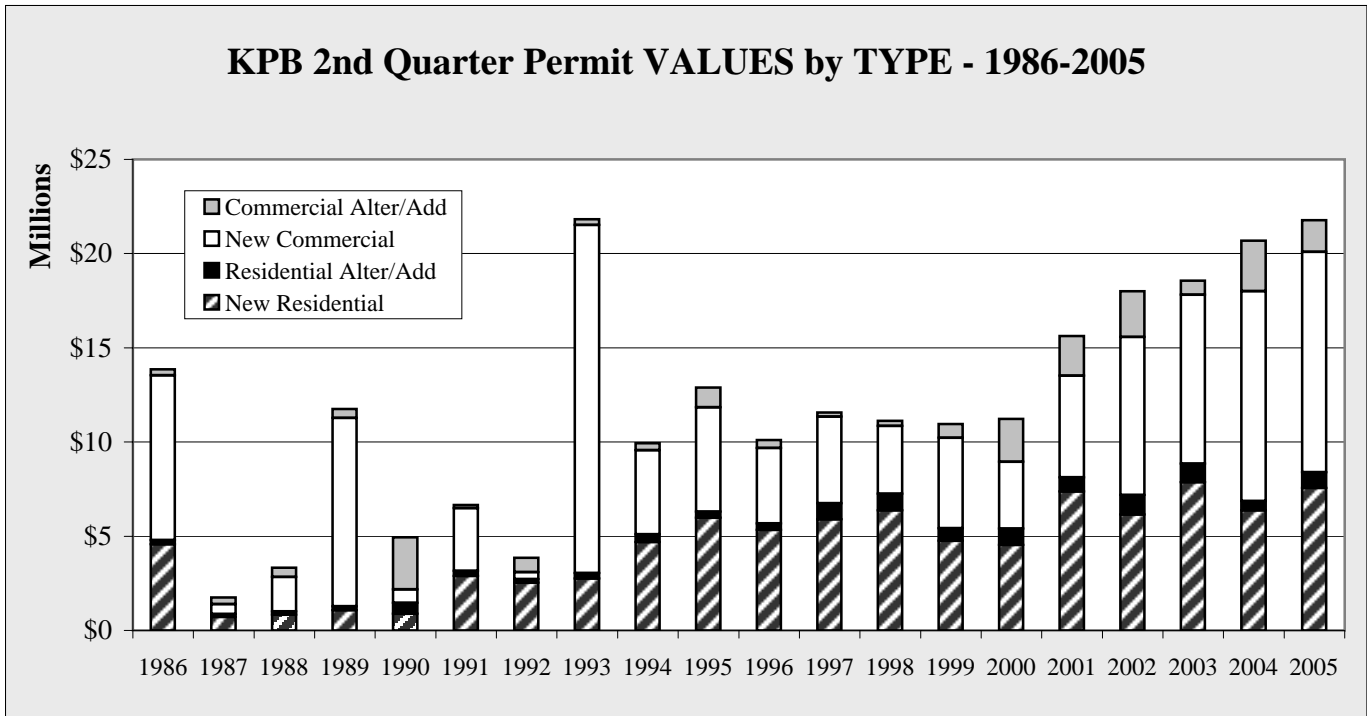

Chart 1.33

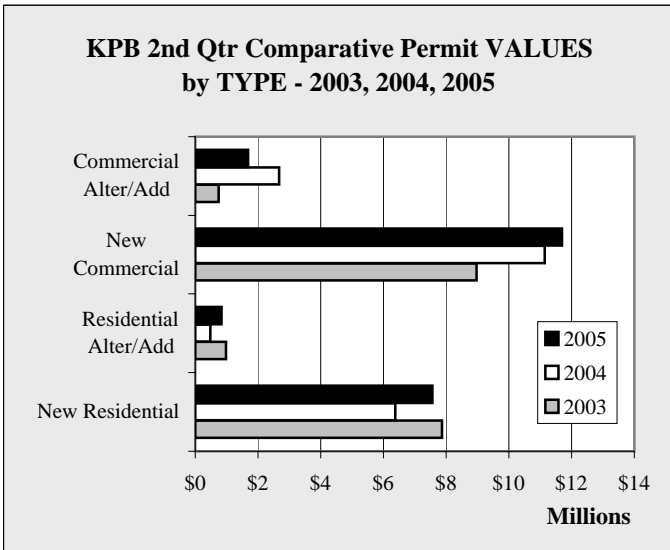

Chart 1.34

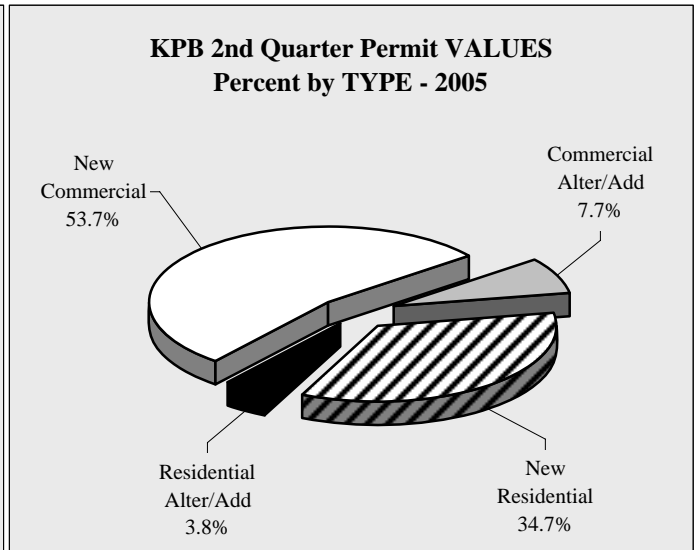

Chart 1.35

# KPB Construction

## KPB 2nd Quarter Permit VOLUME by TYPE - 1999-2005

	1999	2000	2001	2002	2003	2004	2005	Annual Change
New Residential	38	32	45	45	47	34	49	44.1%
Residential Alter/Add	36	38	38	42	33	30	52	73.3%
New Commercial	20	13	9	17	17	11	23	109.1%
Commercial Alter/Add	22	30	36	32	26	31	22	-29.0%
<b>Total</b>	<b>116</b>	<b>113</b>	<b>128</b>	<b>136</b>	<b>123</b>	<b>106</b>	<b>146</b>	<b>37.7%</b>
<b>Annual Change</b>		<b>-2.6%</b>	<b>13.3%</b>	<b>6.3%</b>	<b>-9.6%</b>	<b>-13.8%</b>	<b>37.7%</b>	

Table 1.44

## KPB 2nd Quarter Permit VOLUME by TYPE - 1986-2005

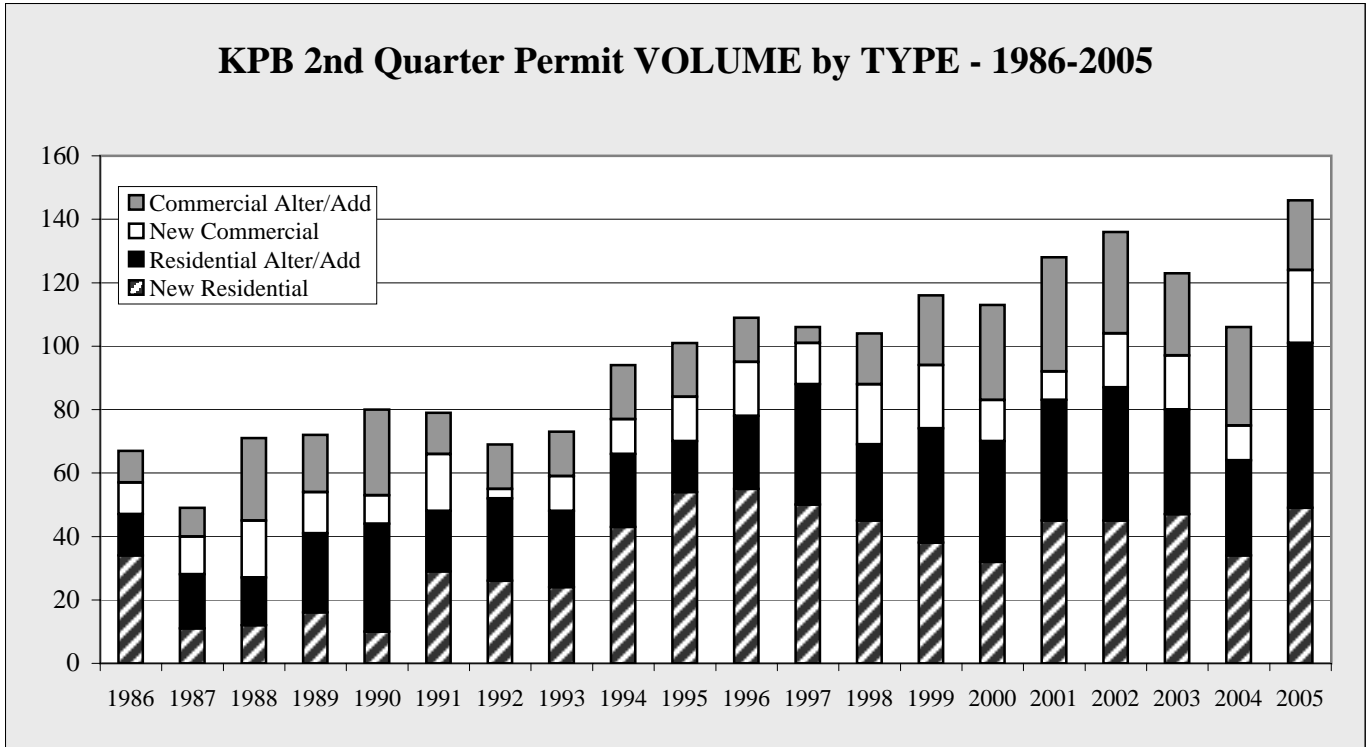

Chart 1.36

### KPB 2nd Qtr Comparative VOLUME by TYPE 2003, 2004, 2005

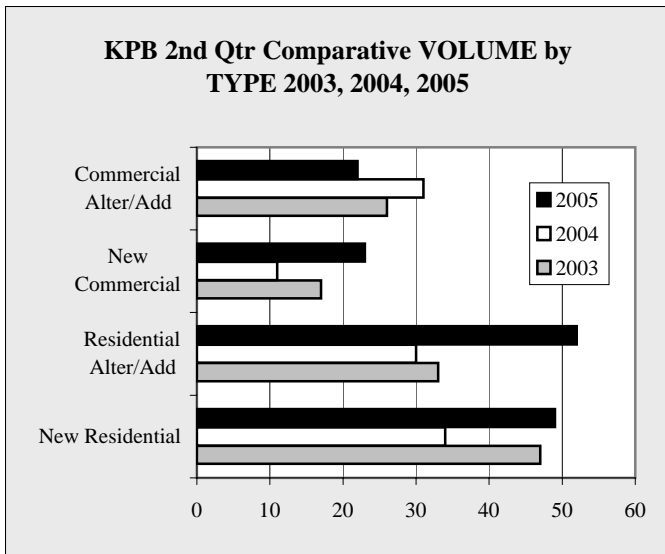

Chart 1.37

### KPB 2nd Quarter Permit VOLUME Percent by TYPE - 2005

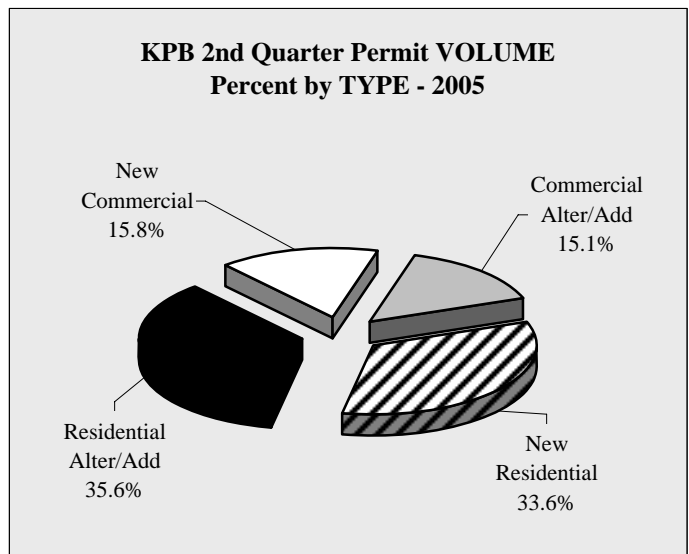

Chart 1.38

# KPB Construction

<b>KPB YTD 6/30 Permit VALUES by AREA - 1999-2005 - in \$</b>								
	1999	2000	2001	2002	2003	2004	2005	Annual Change
Homer	4,634,000	4,064,020	4,792,040	3,456,929	9,263,840	11,147,731	14,347,900	28.7%
Kenai	2,262,100	3,625,900	8,417,400	8,457,600	4,285,950	2,209,400	2,982,800	35.0%
Seldovia	373,500	46,300	35,000	18,000	31,000	176,200	481,000	173.0%
Seward	2,122,664	2,120,700	1,082,939	4,370,327	5,577,365	15,185,500	2,176,840	-85.7%
Soldotna	4,868,748	5,087,558	6,282,408	8,209,048	4,660,942	8,812,896	8,253,790	-6.3%
<b>Total</b>	<b>14,261,012</b>	<b>14,944,478</b>	<b>20,609,787</b>	<b>24,511,904</b>	<b>23,819,097</b>	<b>37,531,727</b>	<b>28,242,330</b>	<b>-24.8%</b>
Annual Change		4.8%	37.9%	18.9%	-2.8%	57.6%	-24.8%	

Table 1.45

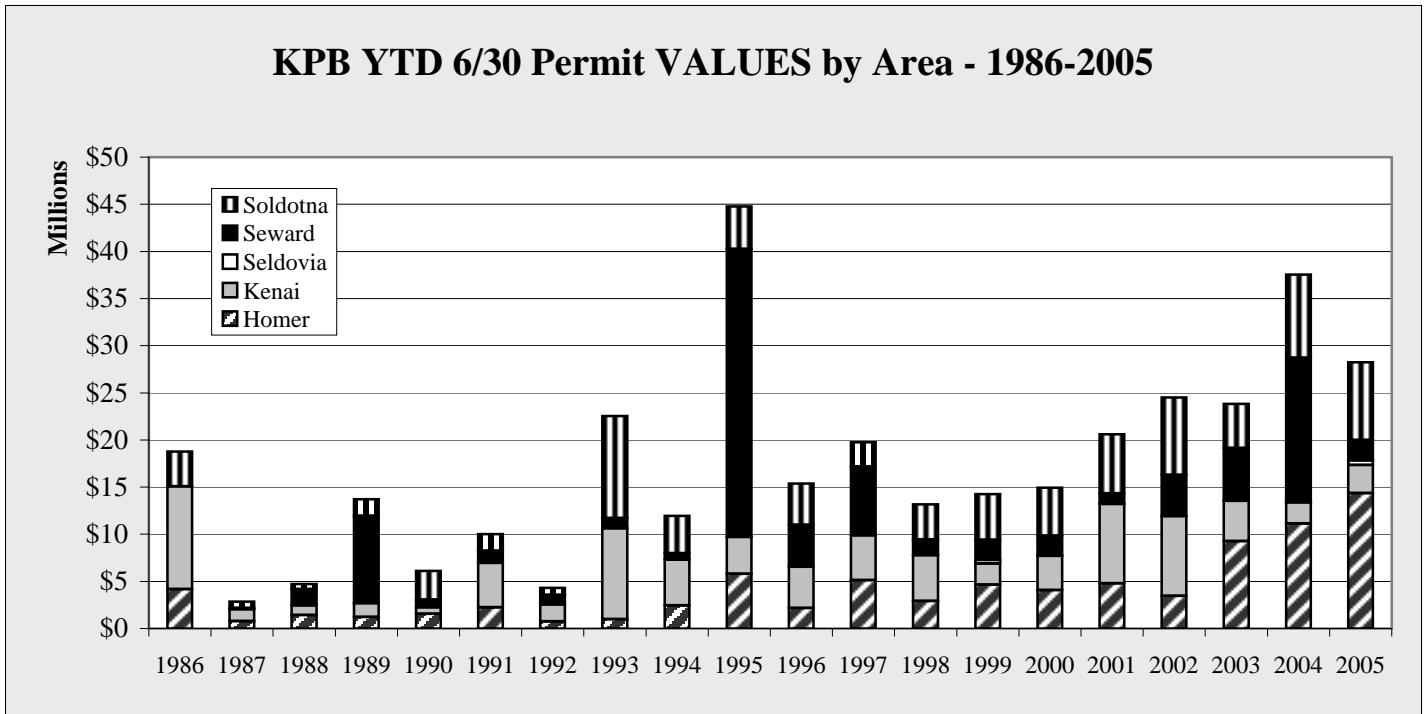

Chart 1.39

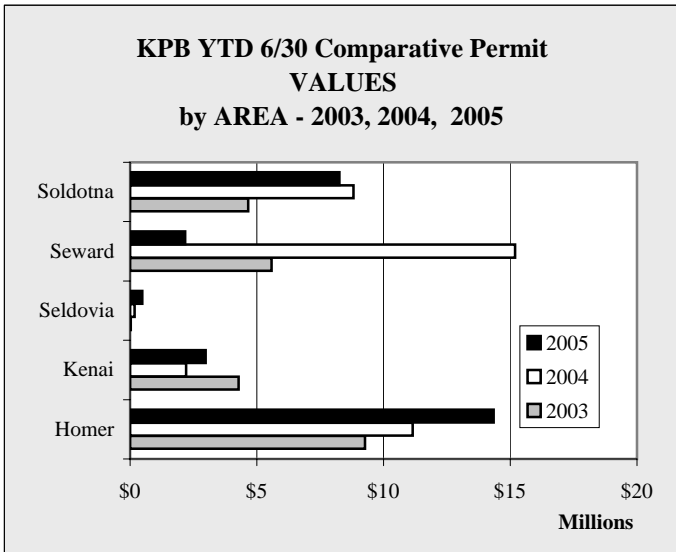

Chart 1.40

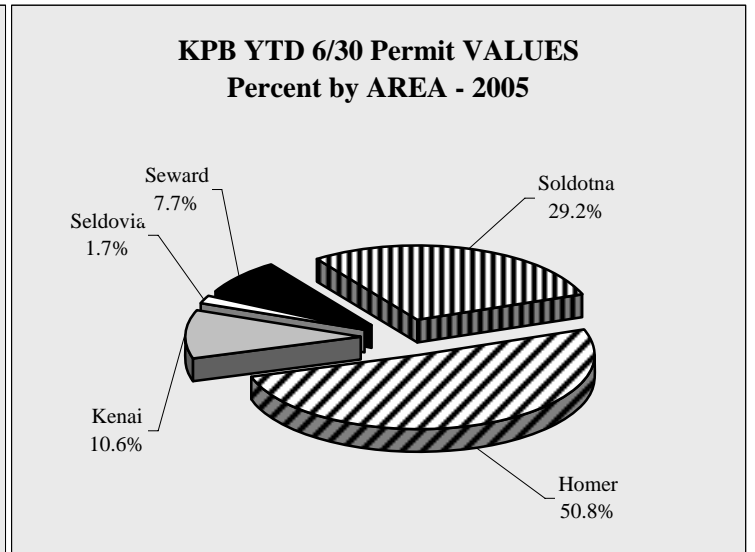

Chart 1.41

# KPB Construction

KPB YTD 6/30 Permit VOLUME by AREA - 1999-2005 - in \$								
	1999	2000	2001	2002	2003	2004	2005	Annual Change
Homer	26	29	41	27	52	42	64	52.4%
Kenai	40	44	53	42	48	34	43	26.5%
Seldovia	10	6	2	3	3	4	7	75.0%
Seward	23	25	25	39	24	28	34	21.4%
Soldotna	45	42	47	62	42	35	56	60.0%
Total	144	146	168	173	169	143	204	42.7%
Annual Change		1.4%	15.1%	3.0%	-2.3%	-15.4%	42.7%	

Table 1.46

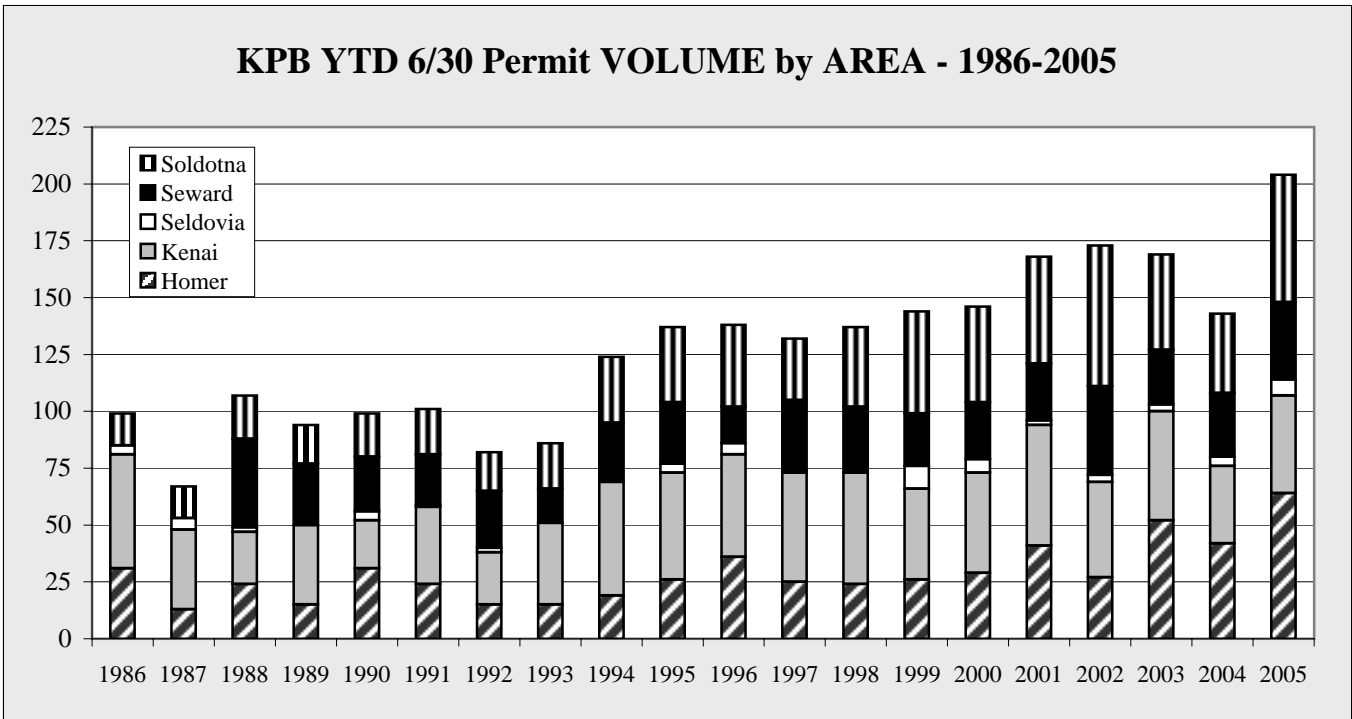

Chart 1.42

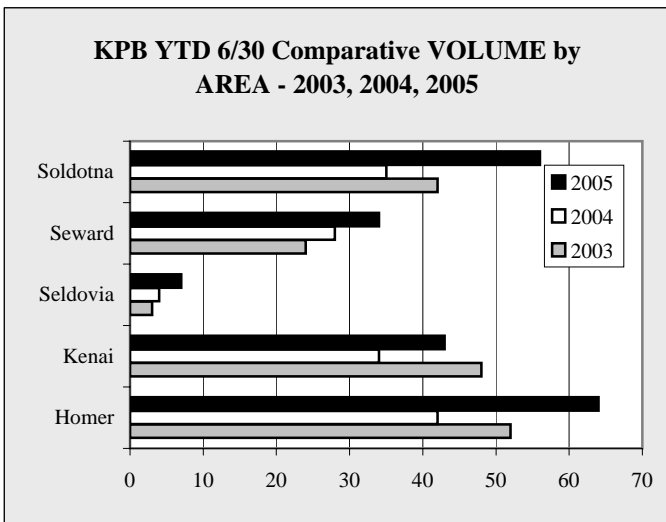

Chart 1.43

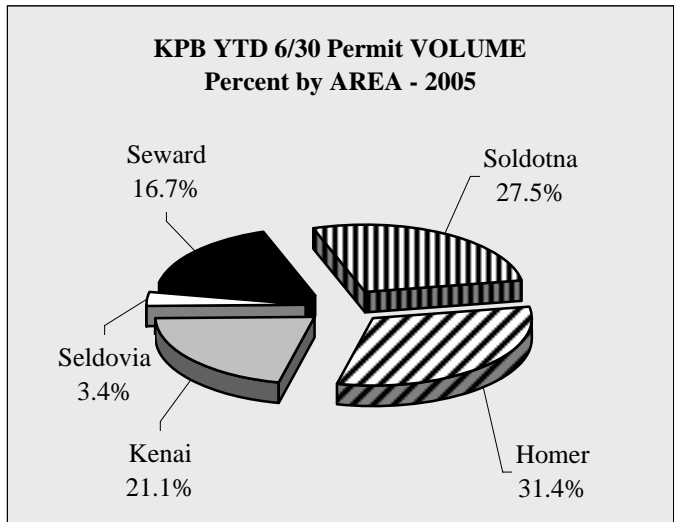

Chart 1.44

# KPB Construction

KPB YTD 6/30 Permit VALUES by TYPE - 1999-2005 - in \$								
	1999	2000	2001	2002	2003	2004	2005	Annual Change
Residential New	6,427,674	5,774,460	8,290,801	7,677,362	8,966,634	9,831,284	11,030,855	12.2%
Residential Alter/Add	849,161	879,074	1,115,639	1,204,334	1,378,207	745,359	1,252,700	68.1%
Commercial New	5,091,318	4,233,395	8,343,378	12,670,311	9,037,210	24,027,841	12,201,848	-49.2%
Commercial Alter/Add	1,892,859	4,057,549	2,859,969	2,959,897	4,437,046	2,927,243	3,756,927	28.3%
<b>Total</b>	<b>14,261,012</b>	<b>14,944,478</b>	<b>20,609,787</b>	<b>24,511,904</b>	<b>23,819,097</b>	<b>37,531,727</b>	<b>28,242,330</b>	<b>-24.8%</b>
Annual Change		4.8%	37.9%	18.9%	-2.8%	57.6%	-24.8%	

Table 1.47

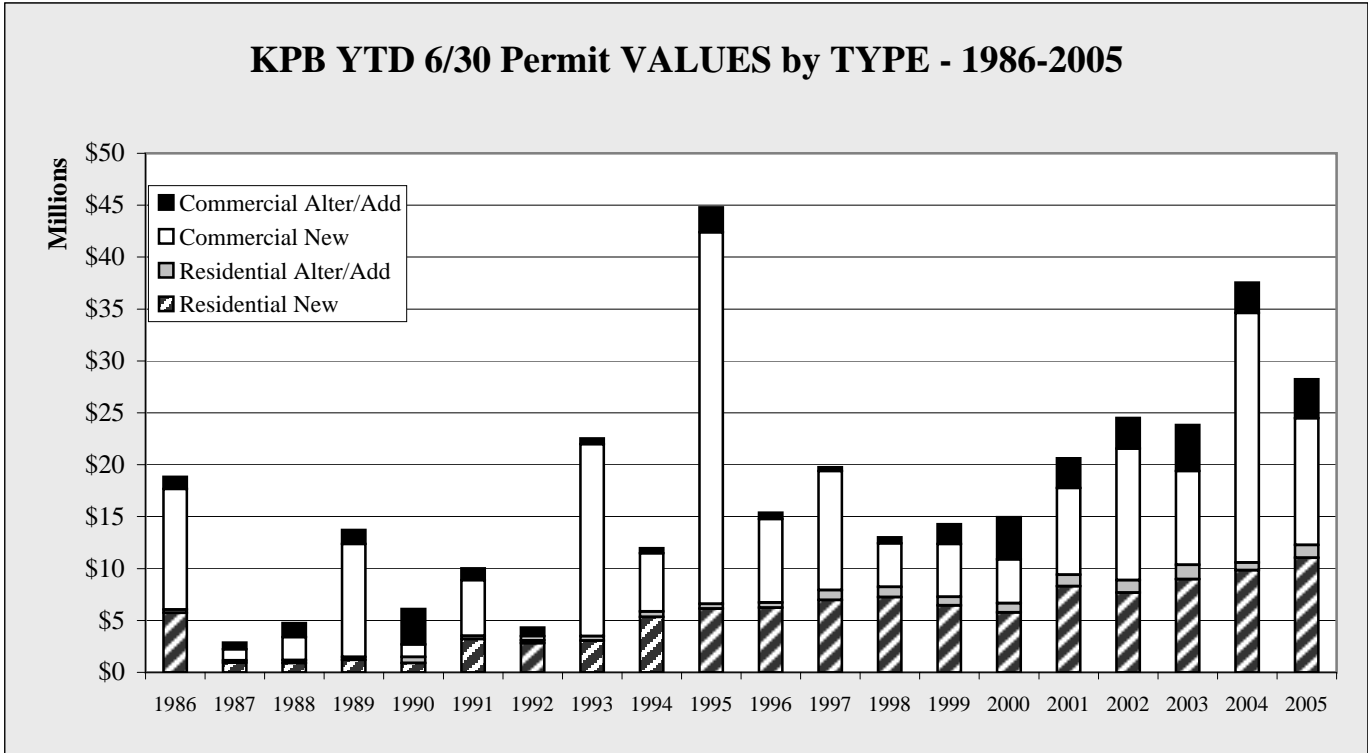

Chart 1.45

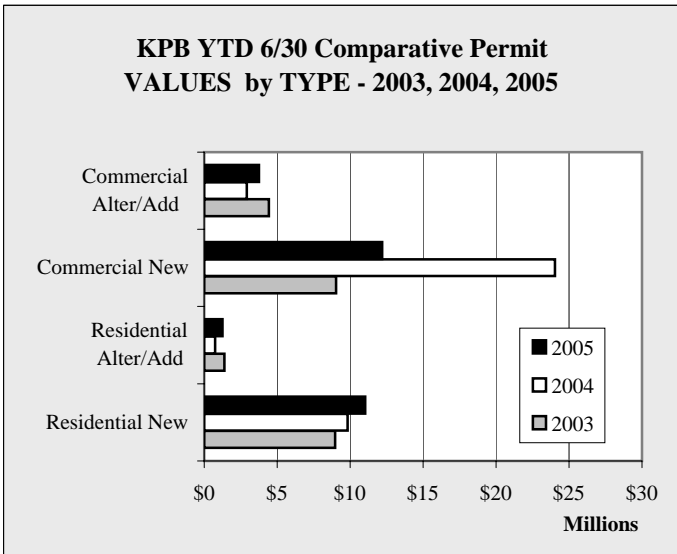

Chart 1.46

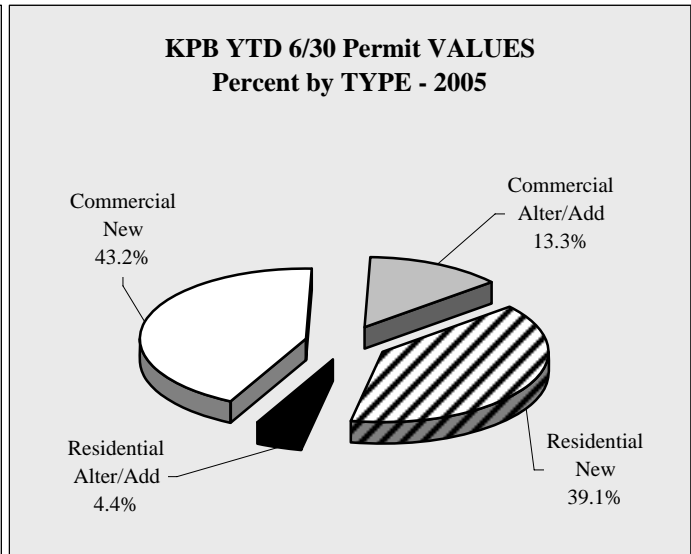

Chart 1.47

# KPB Construction

KPB YTD 6/30 Permit VOLUME by TYPE - 1999-2005								
	1999	2000	2001	2002	2003	2004	2005	Annual Change
Residential New	41	42	52	57	54	51	67	31.4%
Residential Alter/Add	44	42	51	50	50	35	67	91.4%
Commercial New	24	17	15	22	18	18	29	61.1%
Commercial Alter/Add	35	45	50	44	47	39	41	5.1%
<b>Total</b>	<b>144</b>	<b>146</b>	<b>168</b>	<b>173</b>	<b>169</b>	<b>143</b>	<b>204</b>	<b>42.7%</b>
Annual Change		1.4%	15.1%	3.0%	-2.3%	-15.4%	42.7%	

Table 1.48

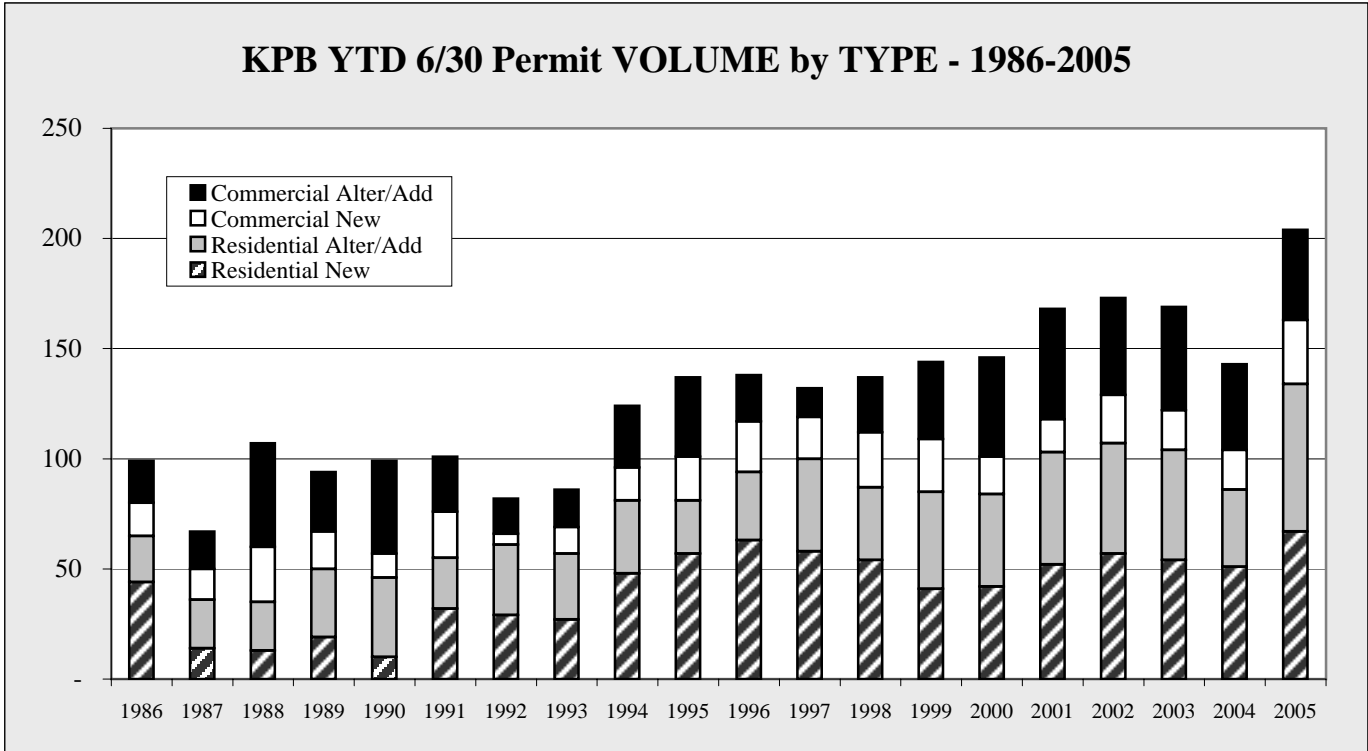

Chart 1.48

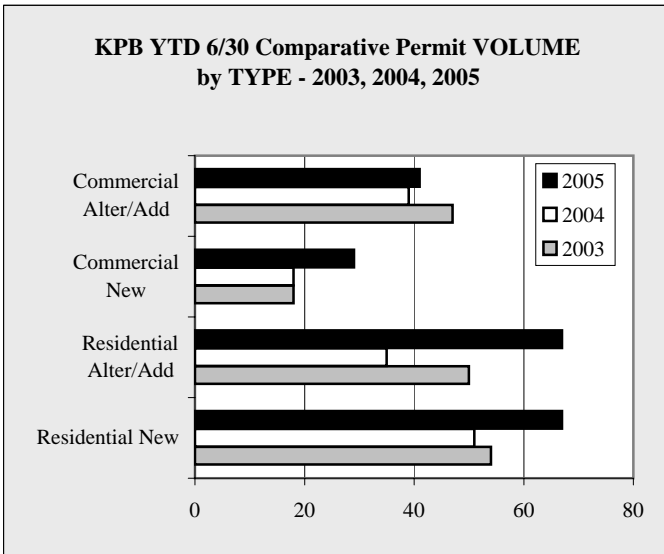

Chart 1.49

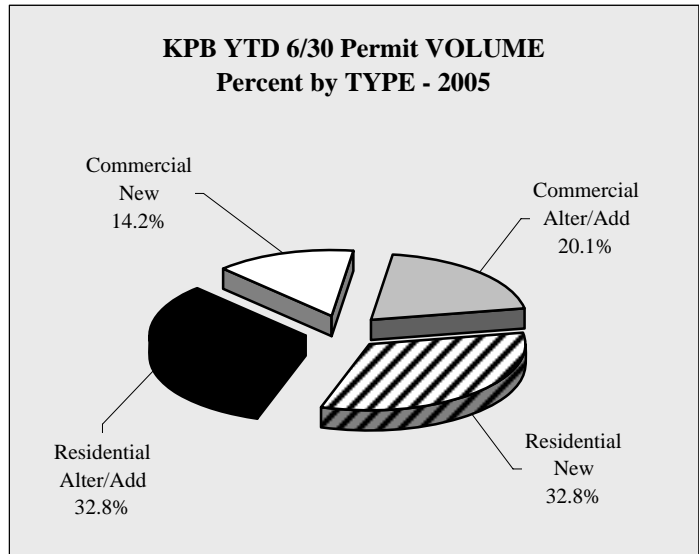

Chart 1.50

# KPB Construction

**KPB Annual Permit VALUES by AREA- 1998-2004 - in \$**

	1998	1999	2000	2001	2002	2003	2004	Annual Change
Homer	6,199,875	10,940,000	7,128,972	19,800,690	10,048,779	15,326,815	24,070,631	57.0%
Kenai	7,642,200	9,441,750	9,398,100	13,578,900	16,799,400	10,441,800	4,786,550	-54.2%
Seldovia	0	479,000	109,200	65,525	356,500	1,902,500	176,200	-90.7%
Seward	6,747,861	4,241,413	3,451,565	2,716,981	7,910,703	7,982,765	17,711,150	121.9%
Soldotna	9,621,817	9,505,120	8,167,420	8,954,972	11,163,894	7,952,297	37,296,926	369.0%
Total	30,211,753	34,607,283	28,255,257	45,117,068	46,279,276	43,606,177	84,041,457	92.7%
Annual Change		14.5%	-18.4%	59.7%	2.6%	-5.8%	92.7%	

Table 1.49

**KPB Annual Permit VALUES by AREA - 1986-2004**

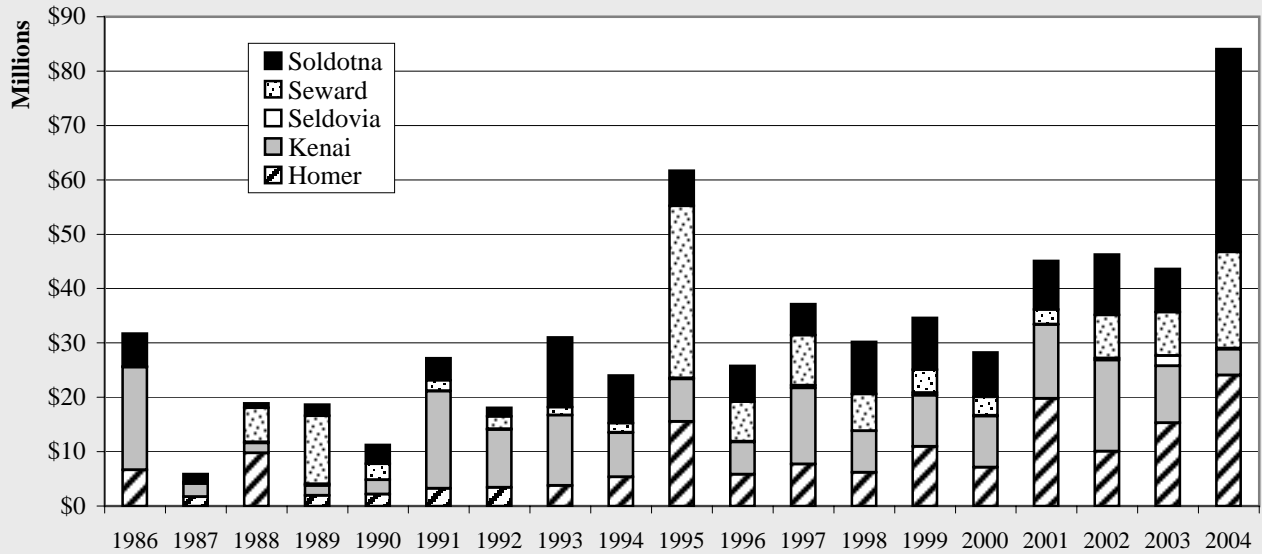

Chart 1.51

**KPB Comparative Permit VALUES by AREA - 2002, 2003, 2004**

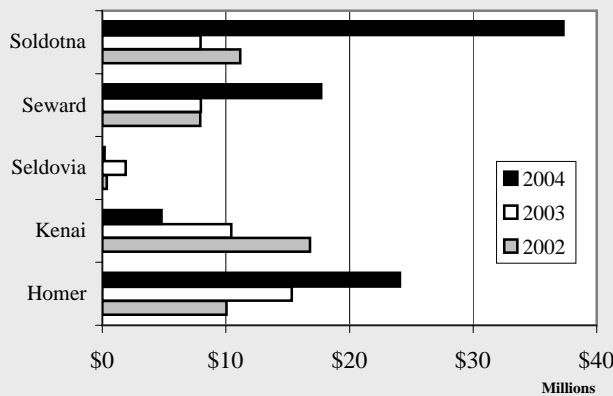

Chart 1.52

**KPB Annual Permit VALUES Percent by AREA - 2004**

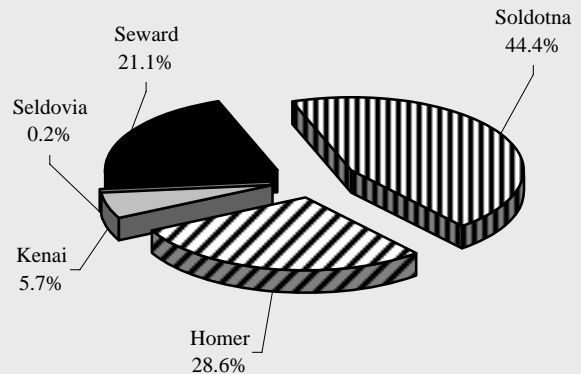

Chart 1.53



# KPB Construction

<b>KPB Annual Permit VOLUME by AREA- 1998-2004</b>								
	1998	1999	2000	2001	2002	2003	2004	Annual Change
Homer	48	52	58	72	67	86	108	25.6%
Kenai	97	102	93	87	121	114	79	-30.7%
Seldovia	0	20	13	9	8	12	4	-66.7%
Seward	49	56	51	48	64	50	54	8.0%
Soldotna	77	77	88	93	91	74	67	-9.5%
<b>Total</b>	<b>271</b>	<b>307</b>	<b>303</b>	<b>309</b>	<b>351</b>	<b>336</b>	<b>312</b>	<b>-7.1%</b>
Annual Change		13.3%	-1.3%	2.0%	13.6%	-4.3%	-7.1%	

Table 1.50

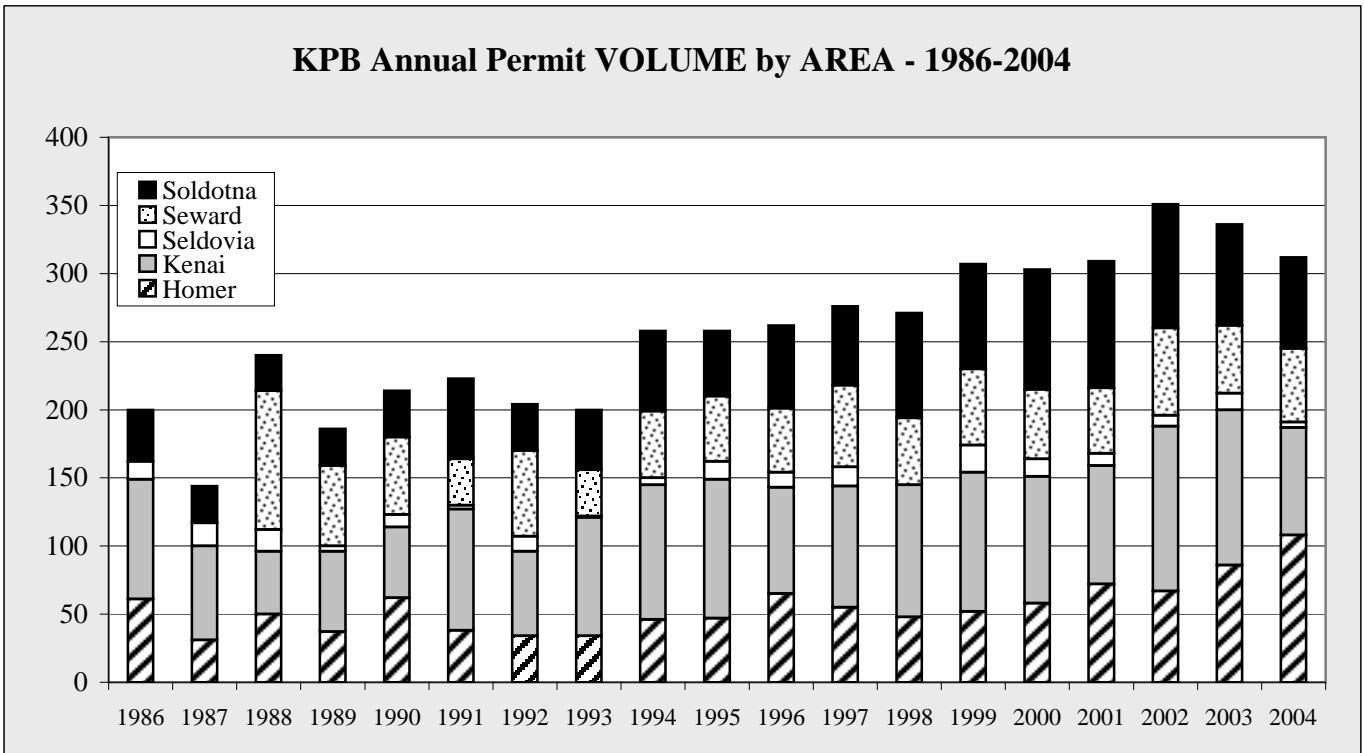

Chart 1.54

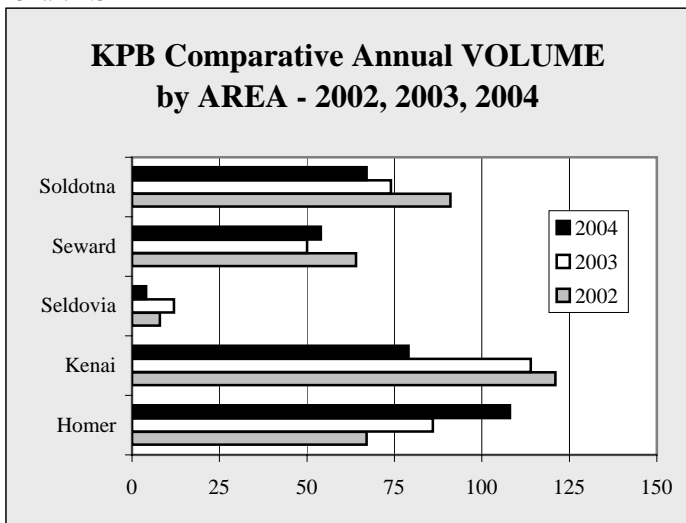

Chart 1.55

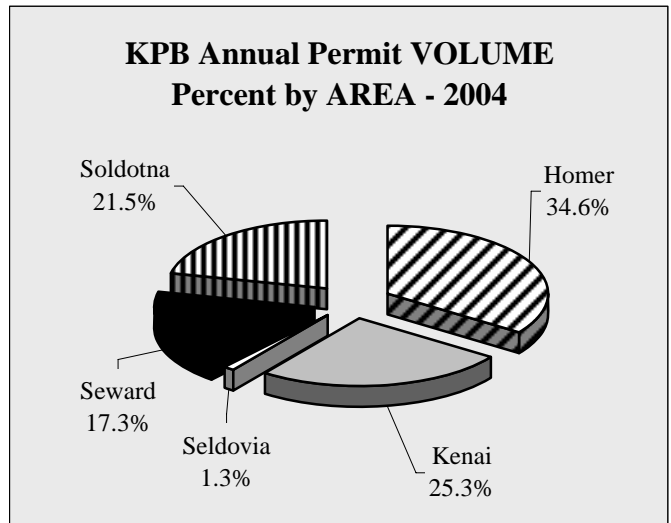

Chart 1.56

# KPB Construction

**KPB Annual Permit VALUES by TYPE - 1998-2004 - in \$**

	1998	1999	2000	2001	2002	2003	2004	Annual Change
Residential New	12,376,250	11,395,862	9,885,058	13,391,633	14,358,064	15,729,888	15,935,344	1.3%
Residential Alter/Add	1,747,903	1,834,828	1,990,399	1,996,494	2,305,815	2,280,779	2,880,284	26.3%
Commercial New	13,494,922	18,862,564	10,662,544	11,565,350	21,793,729	15,820,201	56,079,343	254.5%
Commercial Alter/Add	2,592,678	2,514,029	5,717,256	18,163,591	7,821,668	9,775,309	9,146,486	-6.4%
Total	30,211,753	34,607,283	28,255,257	45,117,068	46,279,276	43,606,177	84,041,457	92.7%
Annual Change		14.5%	-18.4%	59.7%	2.6%	-5.8%	92.7%	

Table 1.51

**KPB Annual Permit VALUES by TYPE - 1986-2004**

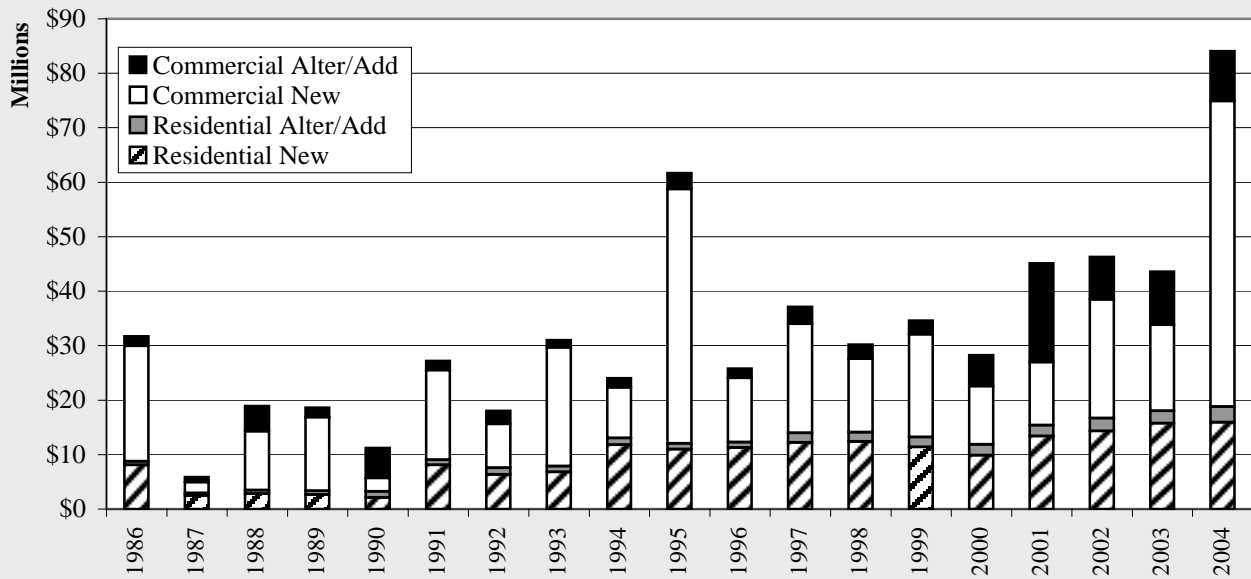

Chart 1.57

**KPB Comparative Annual VALUES by TYPE - 2002, 2003, 2004**

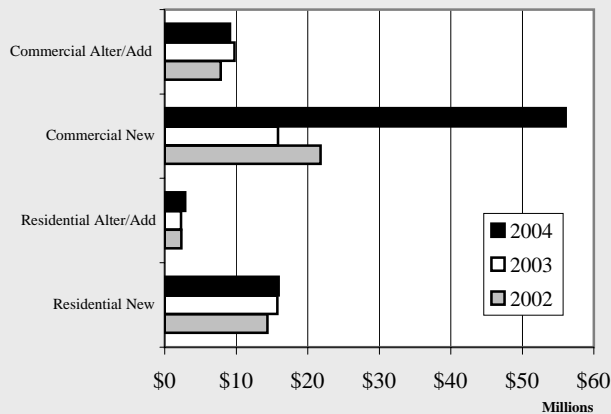

Chart 1.58

**KPB Annual Permit VALUES Percent by TYPE - 2004**

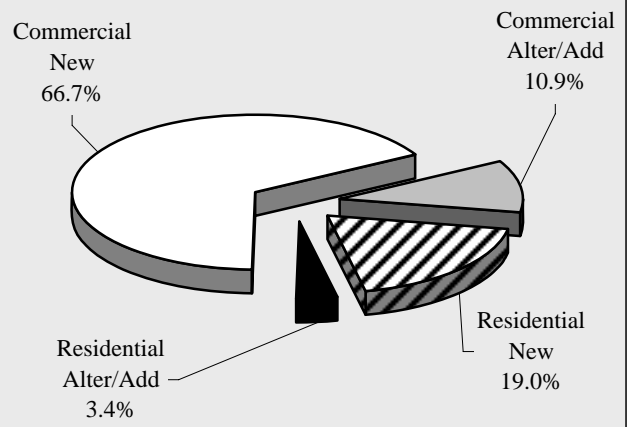

Chart 1.59

# KPB Construction

**KPB Annual Permit VOLUME by TYPE - 1998-2004**

	1998	1999	2000	2001	2002	2003	2004	Annual Change
Residential New	92	79	79	89	104	104	94	-9.6%
Residential Alter/Add	78	98	97	96	116	94	96	2.1%
Commercial New	48	57	45	32	43	42	42	0.0%
Commercial Alter/Add	53	73	82	92	88	96	80	-16.7%
<b>Total</b>	<b>271</b>	<b>307</b>	<b>303</b>	<b>309</b>	<b>351</b>	<b>336</b>	<b>312</b>	<b>-7.1%</b>
Annual Change		13.3%	-1.3%	2.0%	13.6%	-4.3%	-7.1%	

Table 1.52

**KPB Annual Permit VOLUME by TYPE - 1986-2004**

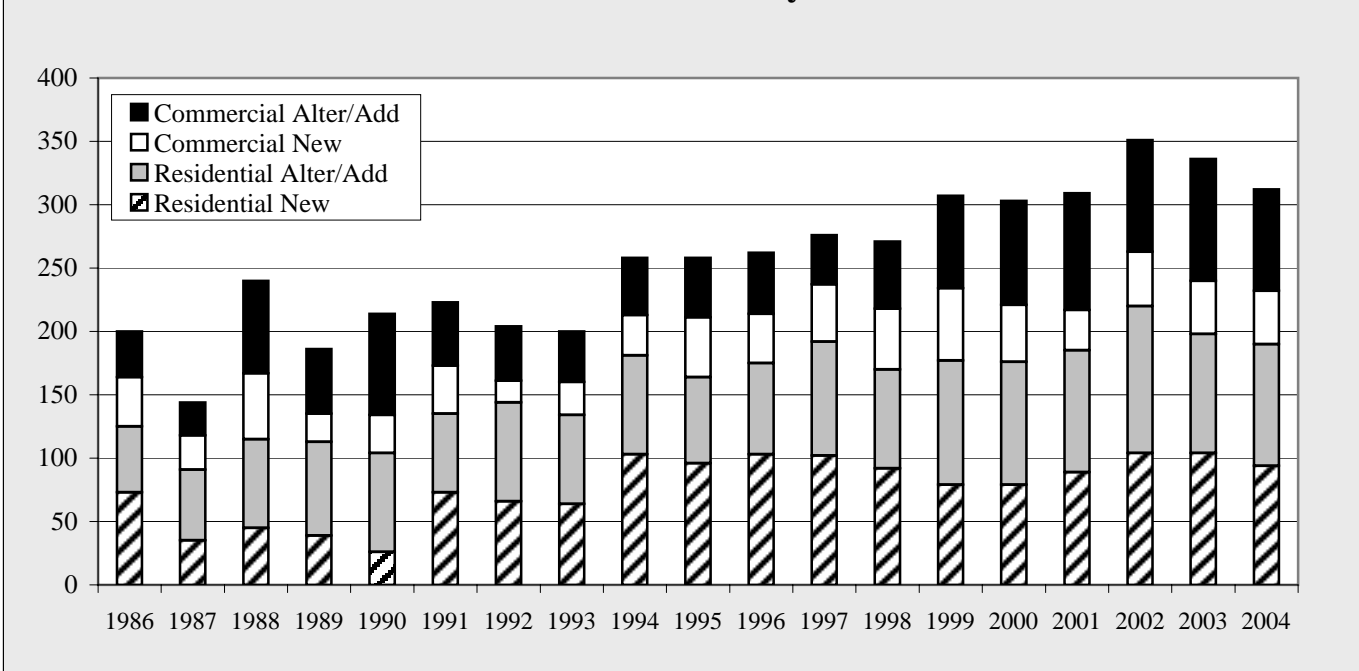

Chart 1.60

**KPB Comparative Annual Permit VOLUME by TYPE - 2002, 2003, 2004**

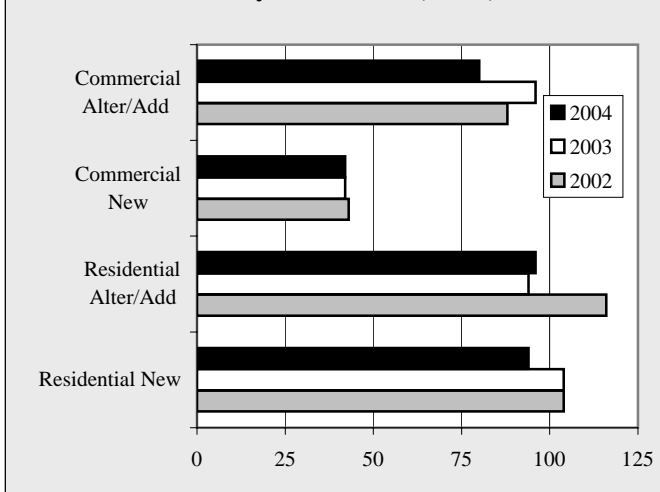

Chart 1.61

**KPB Annual Permit VOLUME Percent by TYPE - 2004**

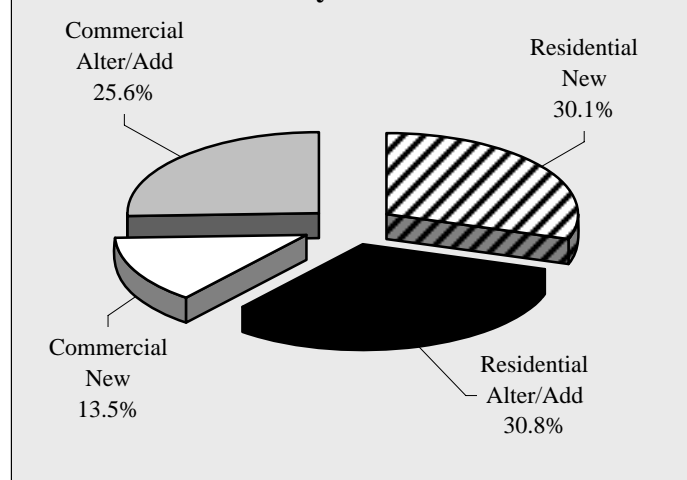

Chart 1.62

# KPB Construction

<b>KPB Annual Permit VALUES by AREA by Quarter - 1999-2005 - in \$</b>					
	1st Quarter	2nd Quarter	3rd Quarter	4th Quarter	Total
<b>1999</b>					
Homer	1,943,000	2,691,000	5,745,000	561,000	10,940,000
Kenai	239,500	2,022,600	6,122,650	1,057,000	9,441,750
Seldovia	8,000	365,500	87,500	18,000	479,000
Seward	1,040,550	1,082,114	1,615,749	503,000	4,241,413
Soldotna	83,696	4,785,052	4,126,579	509,793	9,505,120
<b>TOTAL</b>	<b>3,314,746</b>	<b>10,946,266</b>	<b>17,697,478</b>	<b>2,648,793</b>	<b>34,607,283</b>
<b>2000</b>					
Homer	1,798,100	2,265,920	2,146,970	917,982	7,128,972
Kenai	462,900	3,163,000	5,094,000	678,200	9,398,100
Seldovia	24,000	22,300	57,900	5,000	109,200
Seward	355,300	1,765,400	711,465	619,400	3,451,565
Soldotna	1,078,202	4,009,356	1,676,910	1,402,952	8,167,420
<b>TOTAL</b>	<b>3,718,502</b>	<b>11,225,976</b>	<b>9,687,245</b>	<b>3,623,534</b>	<b>28,255,257</b>
<b>2001</b>					
Homer	690,000	4,102,040	2,996,350	12,012,300	19,800,690
Kenai	819,500	7,597,900	4,506,200	655,300	13,578,900
Seldovia	10,000	25,000	15,525	15,000	65,525
Seward	416,700	666,239	642,042	992,000	2,716,981
Soldotna	3,051,218	3,231,190	2,509,916	162,648	8,954,972
<b>TOTAL</b>	<b>4,987,418</b>	<b>15,622,369</b>	<b>10,670,033</b>	<b>13,837,248</b>	<b>45,117,068</b>
<b>2002</b>					
Homer	928,720	2,528,209	5,777,330	814,520	10,048,779
Kenai	3,888,200	4,569,400	6,814,000	1,527,800	16,799,400
Seldovia	10,000	8,000	318,500	20,000	356,500
Seward	481,440	3,888,887	1,307,576	2,232,800	7,910,703
Soldotna	1,205,590	7,003,458	2,697,346	257,500	11,163,894
<b>TOTAL</b>	<b>6,513,950</b>	<b>17,997,954</b>	<b>16,914,752</b>	<b>4,852,620</b>	<b>46,279,276</b>
<b>2003</b>					
Homer	1,334,340	7,929,500	3,020,075	3,042,900	15,326,815
Kenai	1,557,600	2,728,350	3,700,350	2,455,500	10,441,800
Seldovia	31,000	0	1,835,000	36,500	1,902,500
Seward	1,905,355	3,672,010	1,832,900	572,500	7,982,765
Soldotna	427,018	4,233,924	2,418,310	873,045	7,952,297
<b>TOTAL</b>	<b>5,255,313</b>	<b>18,563,784</b>	<b>12,806,635</b>	<b>6,980,445</b>	<b>43,606,177</b>
<b>2004</b>					
Homer	3,714,020	7,433,711	9,531,900	3,391,000	24,070,631
Kenai	312,000	1,897,400	1,991,750	585,400	4,786,550
Seldovia	20,000	156,200	0	0	176,200
Seward	7,741,600	7,443,900	2,266,300	259,350	17,711,150
Soldotna	5,064,323	3,748,573	23,780,115	4,703,915	37,296,926
<b>TOTAL</b>	<b>16,851,943</b>	<b>20,679,784</b>	<b>37,570,065</b>	<b>8,939,665</b>	<b>84,041,457</b>
<b>2005</b>					
					<b>Year to Date</b>
Homer	3,105,900	11,242,000			14,347,900
Kenai	425,500	2,557,300			2,982,800
Seldovia	15,000	466,000			481,000
Seward	1,507,300	669,540			2,176,840
Soldotna	1,421,555	6,832,235			8,253,790
<b>TOTAL</b>	<b>6,475,255</b>	<b>21,767,075</b>	<b>0</b>	<b>0</b>	<b>28,242,330</b>

Table 1.53

# KPB Construction

<b>KPB Annual Permit VOLUME by AREA by Quarter - 1999-2005</b>					
	1st Quarter	2nd Quarter	3rd Quarter	4th Quarter	Total
<b>1999</b>					
Homer	5	21	20	6	52
Kenai	7	33	40	22	102
Seldovia	1	9	7	3	20
Seward	5	18	23	10	56
Soldotna	10	35	23	9	77
<b>TOTAL</b>	<b>28</b>	<b>116</b>	<b>113</b>	<b>50</b>	<b>307</b>
<b>2000</b>					
Homer	9	20	21	8	58
Kenai	8	36	36	13	93
Seldovia	3	3	6	1	13
Seward	5	20	17	9	51
Soldotna	8	34	26	20	88
<b>TOTAL</b>	<b>33</b>	<b>113</b>	<b>106</b>	<b>51</b>	<b>303</b>
<b>2001</b>					
Homer	7	34	22	9	72
Kenai	11	42	23	11	87
Seldovia	1	1	5	2	9
Seward	11	14	14	9	48
Soldotna	10	37	35	11	93
<b>TOTAL</b>	<b>40</b>	<b>128</b>	<b>99</b>	<b>42</b>	<b>309</b>
<b>2002</b>					
Homer	10	17	27	13	67
Kenai	5	37	59	20	121
Seldovia	1	2	4	1	8
Seward	10	29	14	11	64
Soldotna	11	51	25	4	91
<b>TOTAL</b>	<b>37</b>	<b>136</b>	<b>129</b>	<b>49</b>	<b>351</b>
<b>2003</b>					
Homer	18	34	21	13	86
Kenai	8	40	45	21	114
Seldovia	3	0	5	4	12
Seward	11	13	15	11	50
Soldotna	6	36	19	13	74
<b>TOTAL</b>	<b>46</b>	<b>123</b>	<b>105</b>	<b>62</b>	<b>336</b>
<b>2004</b>					
Homer	16	26	42	24	108
Kenai	4	30	31	14	79
Seldovia	1	3	0	0	4
Seward	7	21	19	7	54
Soldotna	9	26	24	8	67
<b>TOTAL</b>	<b>37</b>	<b>106</b>	<b>116</b>	<b>53</b>	<b>312</b>
<b>2005</b>					
				<b>Year to Date</b>	
Homer	18	46			64
Kenai	10	33			43
Seldovia	1	6			7
Seward	13	21			34
Soldotna	16	40			56
<b>TOTAL</b>	<b>58</b>	<b>146</b>	<b>0</b>	<b>0</b>	<b>204</b>

Table 1.54

# KPB Construction

<b>KPB Annual Permit VALUES by TYPE by Quarter - 1999-2005 - in \$</b>					
	1st Quarter	2nd Quarter	3rd Quarter	4th Quarter	Total
<b>1999</b>					
Residential - New	1,673,000	4,754,674	3,722,300	1,245,888	11,395,862
Residential - Add/Alter	181,200	667,961	694,267	291,400	1,834,828
Commercial - New	292,500	4,798,818	12,808,341	962,905	18,862,564
Commercial - Add/Alter	1,168,046	724,813	472,570	148,600	2,514,029
<b>TOTAL</b>	<b>3,314,746</b>	<b>10,946,266</b>	<b>17,697,478</b>	<b>2,648,793</b>	<b>34,607,283</b>
<b>2000</b>					
Residential - New	1,242,529	4,531,931	3,137,930	972,668	9,885,058
Residential - Add/Alter	18,500	860,574	672,025	439,300	1,990,399
Commercial - New	669,273	3,564,122	4,966,665	1,462,484	10,662,544
Commercial - Add/Alter	1,788,200	2,269,349	910,625	749,082	5,717,256
<b>TOTAL</b>	<b>3,718,502</b>	<b>11,225,976</b>	<b>9,687,245</b>	<b>3,623,534</b>	<b>28,255,257</b>
<b>2001</b>					
Residential - New	923,000	7,367,801	3,984,532	1,116,300	13,391,633
Residential - Add/Alter	356,860	758,779	531,907	348,948	1,996,494
Commercial - New	2,958,578	5,384,800	2,707,972	514,000	11,565,350
Commercial - Add/Alter	748,980	2,110,989	3,445,622	11,858,000	18,163,591
<b>TOTAL</b>	<b>4,987,418</b>	<b>15,622,369</b>	<b>10,670,033</b>	<b>13,837,248</b>	<b>45,117,068</b>
<b>2002</b>					
Residential - New	1,531,609	6,145,753	5,567,502	1,113,200	14,358,064
Residential - Add/Alter	159,391	1,044,943	875,861	225,620	2,305,815
Commercial - New	4,294,006	8,376,305	5,955,418	3,168,000	21,793,729
Commercial - Add/Alter	528,944	2,430,953	4,515,971	345,800	7,821,668
<b>TOTAL</b>	<b>6,513,950</b>	<b>17,997,954</b>	<b>16,914,752</b>	<b>4,852,620</b>	<b>46,279,276</b>
<b>2003</b>					
Residential - New	1,097,800	7,868,834	4,209,163	2,554,091	15,729,888
Residential - Add/Alter	393,867	984,340	611,572	291,000	2,280,779
Commercial - New	72,000	8,965,210	4,636,000	2,146,991	15,820,201
Commercial - Add/Alter	3,691,646	745,400	3,349,900	1,988,363	9,775,309
<b>TOTAL</b>	<b>5,255,313</b>	<b>18,563,784</b>	<b>12,806,635</b>	<b>6,980,445</b>	<b>43,606,177</b>
<b>2004</b>					
Residential - New	3,456,797	6,374,487	4,950,200	1,153,860	15,935,344
Residential - Add/Alter	261,520	483,839	1,605,471	529,454	2,880,284
Commercial - New	12,880,026	11,147,815	28,989,901	3,061,601	56,079,343
Commercial - Add/Alter	253,600	2,673,643	2,024,493	4,194,750	9,146,486
<b>TOTAL</b>	<b>16,851,943</b>	<b>20,679,784</b>	<b>37,570,065</b>	<b>8,939,665</b>	<b>84,041,457</b>
<b>2005</b>					
					<b>Year to Date</b>
Residential - New	3,470,356	7,560,499			11,030,855
Residential - Add/Alter	418,930	833,770			1,252,700
Commercial - New	509,000	11,692,848			12,201,848
Commercial - Add/Alter	2,076,969	1,679,958			3,756,927
<b>TOTAL</b>	<b>6,475,255</b>	<b>21,767,075</b>	<b>0</b>	<b>0</b>	<b>28,242,330</b>

Table 1.55

# KPB Construction

<b>KPB Annual Permit VOLUME by TYPE by Quarter - 1999-2005</b>					
	1st Quarter	2nd Quarter	3rd Quarter	4th Quarter	Total
<b>1999</b>					
Residential - New	3	38	25	13	79
Residential - Add/Alter	8	36	36	18	98
Commercial - New	4	20	24	9	57
Commercial - Add/Alter	13	22	28	10	73
<b>TOTAL</b>	<b>28</b>	<b>116</b>	<b>113</b>	<b>50</b>	<b>307</b>
<b>2000</b>					
Residential - New	10	32	28	9	79
Residential - Add/Alter	4	38	40	15	97
Commercial - New	4	13	16	12	45
Commercial - Add/Alter	15	30	22	15	82
<b>TOTAL</b>	<b>33</b>	<b>113</b>	<b>106</b>	<b>51</b>	<b>303</b>
<b>2001</b>					
Residential - New	7	45	29	8	89
Residential - Add/Alter	13	38	31	14	96
Commercial - New	6	9	15	2	32
Commercial - Add/Alter	14	36	24	18	92
<b>TOTAL</b>	<b>40</b>	<b>128</b>	<b>99</b>	<b>42</b>	<b>309</b>
<b>2002</b>					
Residential - New	12	45	38	9	104
Residential - Add/Alter	8	42	49	17	116
Commercial - New	5	17	14	7	43
Commercial - Add/Alter	12	32	28	16	88
<b>TOTAL</b>	<b>37</b>	<b>136</b>	<b>129</b>	<b>49</b>	<b>351</b>
<b>2003</b>					
Residential - New	7	47	28	22	104
Residential - Add/Alter	17	33	34	10	94
Commercial - New	1	17	17	7	42
Commercial - Add/Alter	21	26	26	23	96
<b>TOTAL</b>	<b>46</b>	<b>123</b>	<b>105</b>	<b>62</b>	<b>336</b>
<b>2004</b>					
Residential - New	17	34	32	11	94
Residential - Add/Alter	5	30	44	17	96
Commercial - New	7	11	15	9	42
Commercial - Add/Alter	8	31	25	16	80
<b>TOTAL</b>	<b>37</b>	<b>106</b>	<b>116</b>	<b>53</b>	<b>312</b>
<b>2005</b>					<b>Year to Date</b>
Residential - New	18	49			67
Residential - Add/Alter	15	52			67
Commercial - New	6	23			29
Commercial - Add/Alter	19	22			41
<b>TOTAL</b>	<b>58</b>	<b>146</b>	<b>0</b>	<b>0</b>	<b>204</b>

Table 1.56

# KPB Employment

Employment data are acquired from the Alaska Department of Labor and Workforce Development (AK DOLWD) as reported by each business.

Government employees include federal, state, borough and local government as well as public school and state university employees. Employees of both Central Peninsula General Hospital in Soldotna and South Peninsula General Hospital in Homer are included in government data rather than service data because they are owned by and receive funds from the KPB.

The AK DOLWD updates employment data regularly. Self-employed workers, fishers, domestics, unpaid family help, most individuals engaged in agriculture and some other smaller worker groups are excluded from these figures due to exemption from certain reporting requirements.

**A change in the way the labor force statistics are calculated for boroughs and census areas makes data prior to 2000 not comparable with data from 2000 forward. Please contact the Alaska Department of Labor for any questions.**

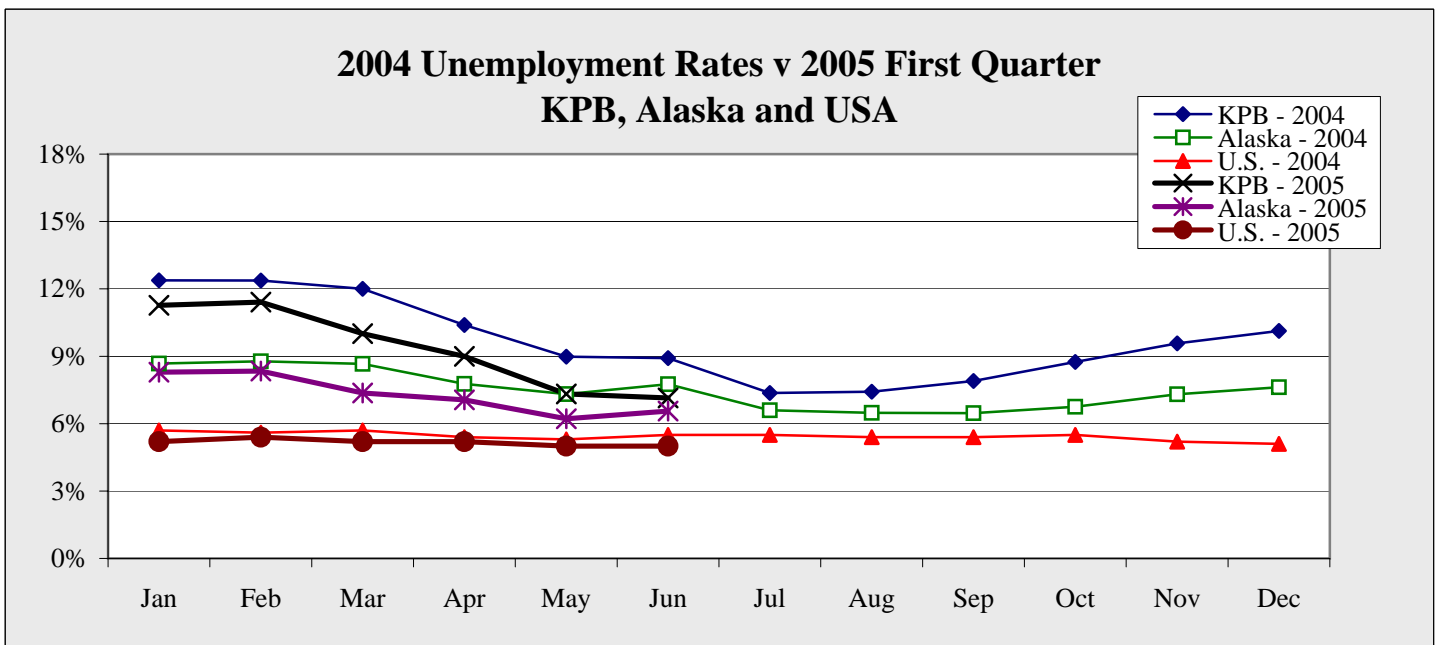

Chart 1.63

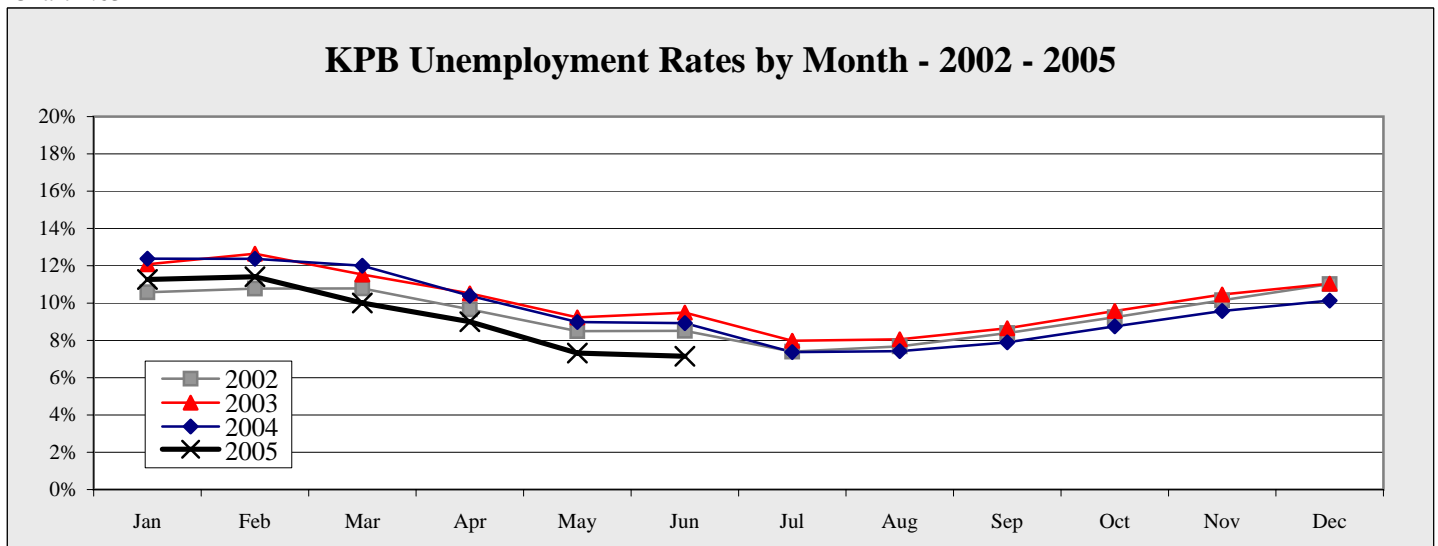

Chart 1.64



# KPB Employment

<b>KPB Labor Force by Month - 1990-2005</b>													
	Jan	Feb	Mar	Apr	May	Jun	Jul	Aug	Sep	Oct	Nov	Dec	Avg
1990	17,564	17,961	17,955	18,541	19,221	20,270	21,443	20,938	18,577	18,540	17,994	17,794	18,900
1991	18,381	18,683	18,701	19,243	19,674	20,785	22,469	21,530	19,892	19,111	18,966	18,699	19,678
1992	18,890	19,623	19,381	19,559	20,145	22,134	22,742	21,332	20,508	20,292	19,350	19,145	20,258
1993	18,480	19,492	19,749	19,900	20,254	22,689	24,023	22,948	20,520	20,560	19,705	19,339	20,638
1994	19,567	21,120	21,186	20,476	20,925	23,088	24,503	23,230	20,969	20,793	19,887	19,262	21,251
1995	20,592	21,194	20,910	20,449	20,994	22,646	24,230	23,407	21,538	21,337	20,292	19,807	21,450
1996	20,912	21,826	21,731	21,498	22,549	23,867	25,493	24,772	23,126	21,813	21,211	20,474	22,439
1997	21,692	22,407	21,900	21,940	21,929	24,014	25,338	24,296	22,369	21,180	20,448	19,878	22,283
1998	20,924	21,090	20,751	20,663	21,492	23,562	24,276	23,694	22,385	21,085	20,105	19,805	21,653
1999	20,653	21,359	21,279	21,368	21,936	23,579	24,619	23,921	22,572	21,575	20,663	20,119	21,970
2000	23,011	23,329	23,290	23,365	24,542	26,598	26,448	26,243	25,160	24,101	24,071	24,174	24,528
2001	23,056	23,003	23,055	23,139	24,195	26,114	26,836	25,619	24,496	23,717	23,656	23,801	24,224
2002	23,659	23,374	23,569	24,173	24,925	25,919	26,796	26,125	24,942	24,317	24,294	24,409	24,709
2003	24,298	24,108	24,243	24,379	25,394	26,781	27,170	26,352	24,571	24,028	23,988	23,875	24,932
2004	23,874	24,000	24,130	24,130	25,302	27,117	27,599	26,342	24,958	24,334	24,116	23,981	24,990
2005	23,873	24,220	24,295	24,749	25,830	27,751							

Table 1.57

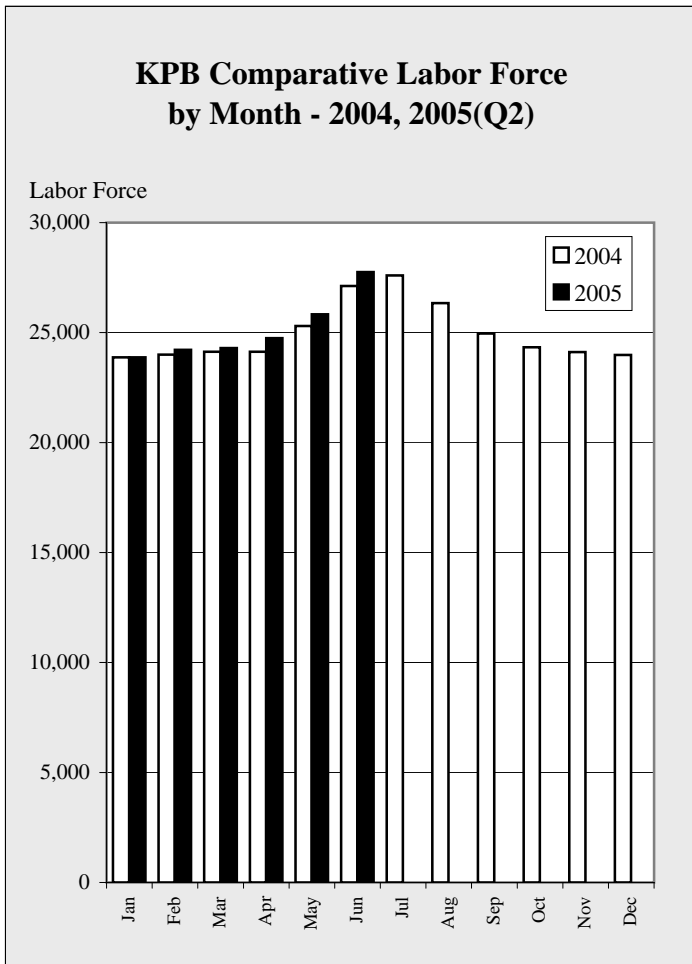

Chart 1.65

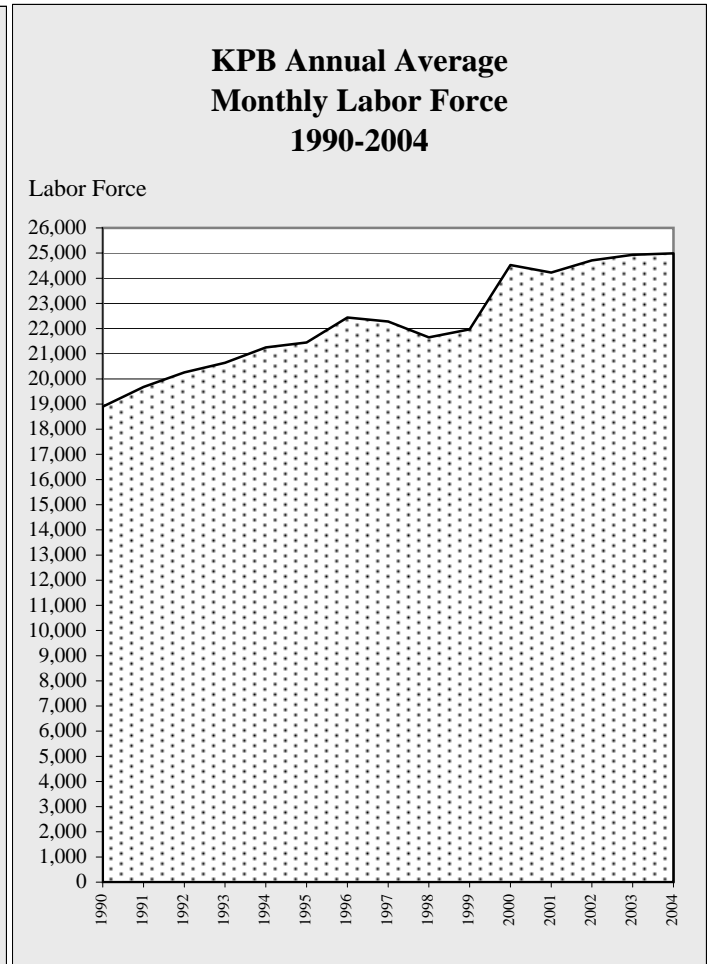

Chart 1.66

# KPB Employment

**KPB Unemployment by Month - 1990-2005**

	Jan	Feb	Mar	Apr	May	Jun	Jul	Aug	Sep	Oct	Nov	Dec	Avg
1990	2,680	2,704	2,484	2,300	2,072	1,938	1,671	1,768	1,929	2,374	2,325	2,317	2,214
1991	2,929	3,023	2,818	2,611	2,323	2,345	2,201	2,078	2,200	2,874	3,348	3,490	2,687
1992	4,153	4,426	3,807	3,385	3,008	3,016	2,564	2,064	2,259	2,960	2,944	3,025	3,134
1993	3,596	3,823	3,357	3,014	2,494	2,439	2,004	1,769	1,752	2,503	2,603	2,660	2,668
1994	3,386	3,668	3,333	2,923	2,533	2,425	2,402	1,988	1,844	2,638	2,481	2,716	2,695
1995	3,616	3,651	3,146	2,638	2,196	2,196	2,154	1,933	1,897	2,654	2,717	2,931	2,644
1996	3,791	4,034	3,447	3,164	2,872	2,680	2,544	2,207	2,676	3,214	3,484	3,512	3,135
1997	4,509	4,549	3,911	3,394	2,709	2,710	2,379	2,054	2,118	2,619	2,675	2,647	3,023
1998	3,051	3,014	2,567	2,147	1,788	1,981	1,644	1,441	1,666	2,002	1,941	2,120	2,114
1999	2,779	3,247	2,779	2,420	2,097	2,119	2,026	1,942	2,076	2,317	2,430	2,549	2,398
2000	2,530	2,575	2,445	2,138	1,943	1,843	1,546	1,556	1,496	1,671	1,871	2,019	1,969
2001	2,327	2,379	2,276	2,045	1,767	1,813	1,543	1,560	1,560	1,754	1,965	2,181	1,931
2002	2,503	2,518	2,542	2,335	2,117	2,207	1,981	2,007	2,092	2,247	2,466	2,690	2,309
2003	2,935	3,048	2,795	2,564	2,345	2,542	2,169	2,122	2,126	2,301	2,508	2,636	2,508
2004	2,956	2,969	2,897	2,508	2,272	2,419	2,033	1,956	1,971	2,129	2,309	2,429	2,404
2005	2,690	2,763	2,431	2,227	1,891	1,983							

Table 1.58

**KPB Comparative Unemployment  
by Month - 2004, 2005 (Q2)**

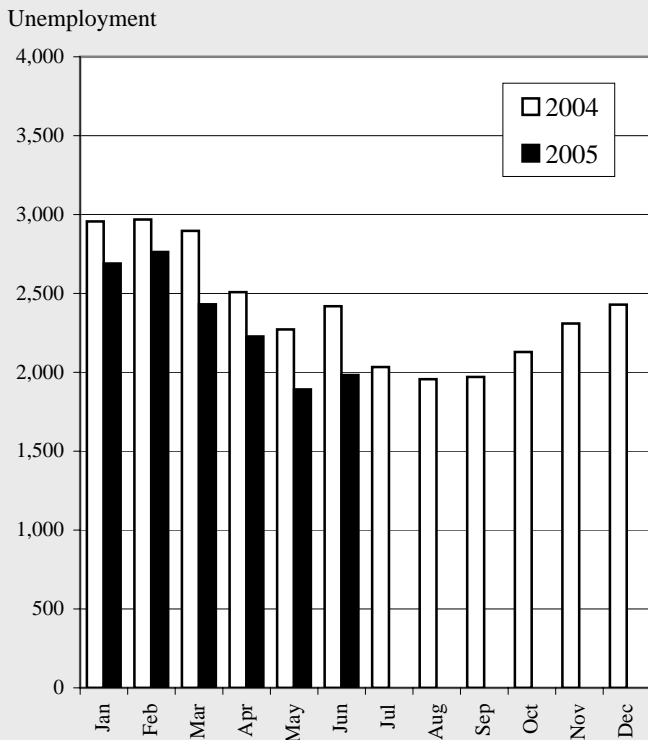

Chart 1.67

**KPB Annual Average  
Monthly Unemployment  
1990-2004**

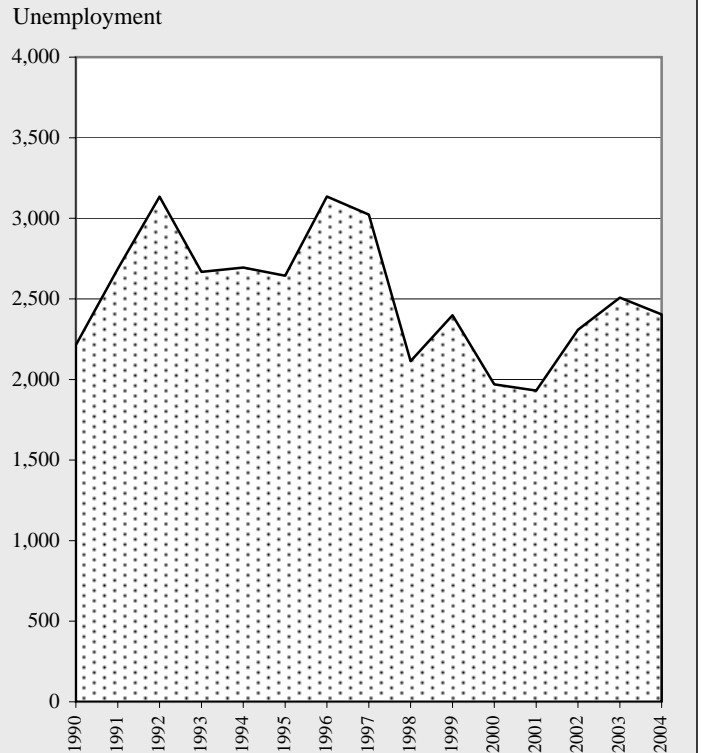

Chart 1.68

# KPB Employment

<b>KPB Unemployment Rates by Month - 1990-2005</b>													
	<u>Jan</u>	<u>Feb</u>	<u>Mar</u>	<u>Apr</u>	<u>May</u>	<u>Jun</u>	<u>Jul</u>	<u>Aug</u>	<u>Sep</u>	<u>Oct</u>	<u>Nov</u>	<u>Dec</u>	<u>Avg</u>
1990	15.3%	15.1%	13.8%	12.4%	10.8%	9.6%	7.8%	8.4%	10.4%	12.8%	12.9%	13.0%	11.9%
1991	15.9%	16.2%	15.1%	13.6%	11.8%	11.3%	9.8%	9.7%	11.1%	15.0%	17.7%	18.7%	13.8%
1992	22.0%	22.6%	19.6%	17.3%	14.9%	13.6%	11.3%	9.7%	11.0%	14.6%	15.2%	15.8%	15.6%
1993	19.5%	19.6%	17.0%	15.1%	12.3%	10.7%	8.3%	7.7%	8.5%	12.2%	13.2%	13.8%	13.2%
1994	17.3%	17.4%	15.7%	14.3%	12.1%	10.5%	9.8%	8.6%	8.8%	12.7%	12.5%	14.1%	12.8%
1995	17.6%	17.2%	15.0%	12.9%	10.5%	9.7%	8.9%	8.3%	8.8%	12.4%	13.4%	14.8%	12.5%
1996	18.1%	18.5%	15.9%	14.7%	12.7%	11.2%	10.0%	8.9%	11.6%	14.7%	16.4%	17.2%	14.2%
1997	20.8%	20.3%	17.9%	15.5%	12.4%	11.3%	9.4%	8.5%	9.5%	12.4%	13.1%	13.3%	13.7%
1998	14.6%	14.3%	12.4%	10.4%	8.3%	8.4%	6.8%	6.1%	7.4%	9.5%	9.7%	10.7%	9.9%
1999	13.5%	15.2%	13.1%	11.3%	9.6%	9.0%	8.2%	8.1%	9.2%	10.7%	11.8%	12.7%	11.0%
2000	11.0%	11.0%	10.5%	9.2%	7.9%	6.9%	5.8%	5.9%	5.9%	6.9%	7.8%	8.4%	8.1%
2001	10.1%	10.3%	9.9%	8.8%	7.3%	6.9%	5.7%	6.1%	6.4%	7.4%	8.3%	9.2%	8.0%
2002	10.6%	10.8%	10.8%	9.7%	8.5%	8.5%	7.4%	7.7%	8.4%	9.2%	10.2%	11.0%	9.4%
2003	12.1%	12.6%	11.5%	10.5%	9.2%	9.5%	8.0%	8.1%	8.7%	9.6%	10.5%	11.0%	10.1%
2004	12.4%	12.4%	12.0%	10.4%	9.0%	8.9%	7.4%	7.4%	7.9%	8.7%	9.6%	10.1%	9.7%
2005	11.3%	11.4%	10.0%	9.0%	7.3%	7.1%							

Table 1.59

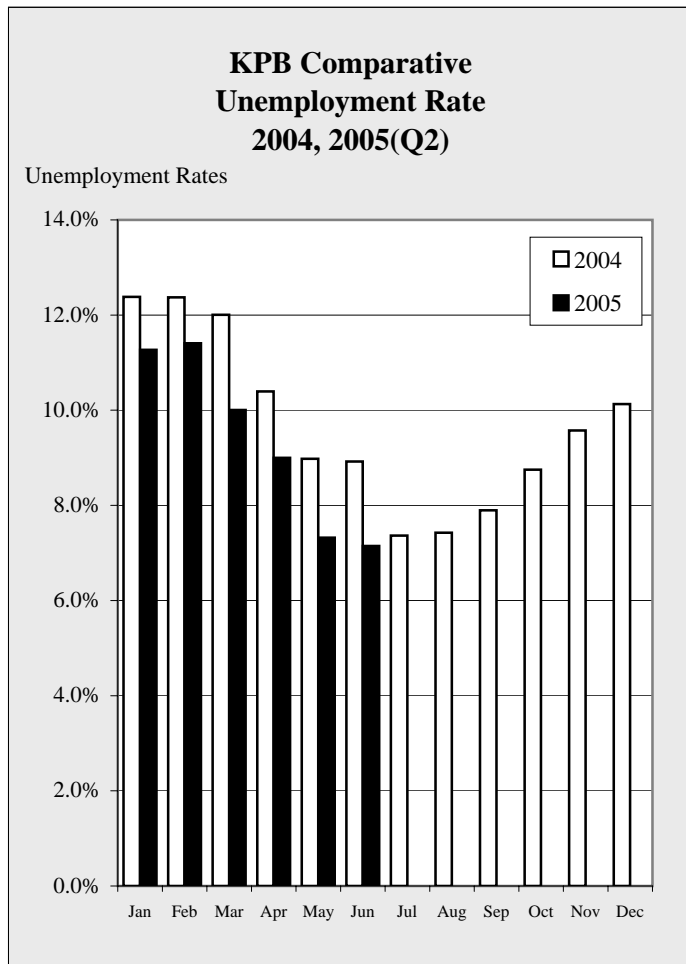

Chart 1.69

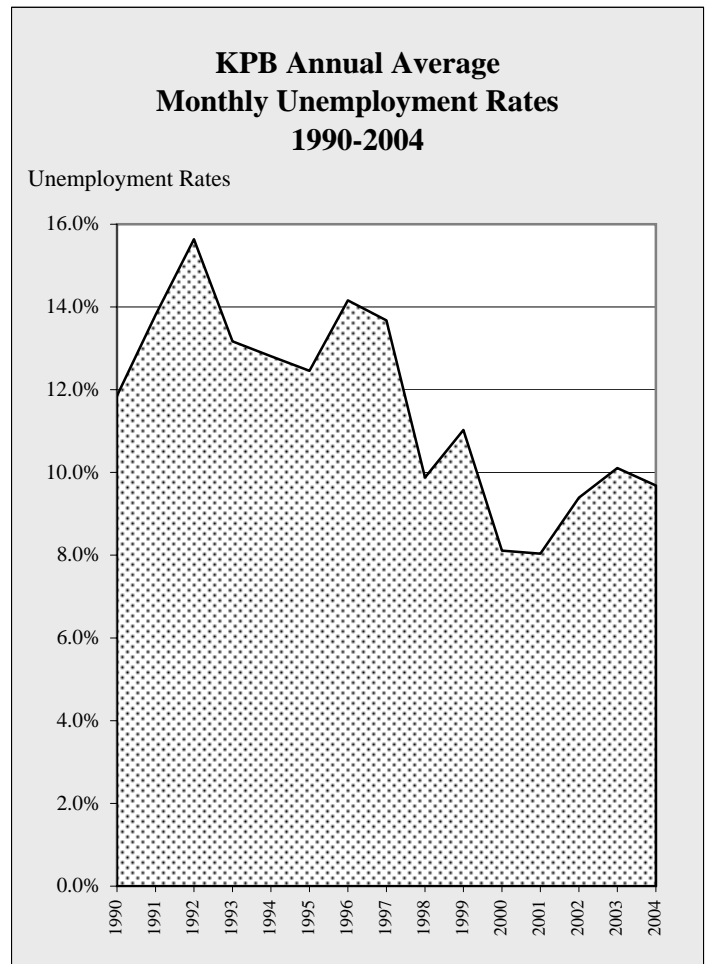

Chart 1.70

# KPB Employment

<b>KPB Employment by Month - 1990-2005</b>													
	<u>Jan</u>	<u>Feb</u>	<u>Mar</u>	<u>Apr</u>	<u>May</u>	<u>Jun</u>	<u>Jul</u>	<u>Aug</u>	<u>Sep</u>	<u>Oct</u>	<u>Nov</u>	<u>Dec</u>	<u>Avg</u>
1990	14,800	15,163	15,456	16,241	17,046	18,312	19,846	19,262	16,707	16,208	15,756	15,496	16,691
1991	15,420	15,652	15,969	16,834	17,423	18,471	20,346	19,563	17,778	16,145	15,521	15,051	17,014
1992	14,576	15,080	15,590	16,299	17,137	19,156	20,256	19,405	18,381	17,329	16,426	16,082	17,143
1993	14,882	15,693	16,486	17,091	17,863	20,352	22,136	21,336	18,902	18,043	17,151	16,607	18,045
1994	16,205	17,470	17,911	17,624	18,429	20,747	22,221	21,452	19,259	18,234	17,511	16,639	18,642
1995	17,014	17,556	17,828	17,855	18,862	20,502	22,203	21,635	19,695	28,715	17,634	16,949	19,704
1996	17,153	17,792	18,284	18,334	19,677	21,187	22,949	22,565	20,450	18,599	17,727	16,962	19,307
1997	17,286	17,858	17,989	18,546	19,220	21,304	22,959	22,242	20,251	18,561	17,773	17,231	19,268
1998	17,668	18,076	18,184	18,516	19,704	21,581	22,632	22,253	20,719	19,083	18,164	17,685	19,522
1999	17,508	18,112	18,500	18,948	19,839	21,460	22,593	21,979	20,496	19,258	18,233	17,570	19,541
2000	20,481	20,754	20,845	21,227	22,599	24,755	24,902	24,687	23,664	22,430	22,200	22,155	22,558
2001	20,729	20,624	20,779	21,094	22,428	24,301	25,293	24,059	22,936	21,963	21,691	21,620	22,293
2002	21,156	20,856	21,027	21,838	22,808	23,712	24,815	24,118	22,850	22,070	21,828	21,719	22,400
2003	21,363	21,060	21,448	21,815	23,049	24,239	25,001	24,230	22,445	21,727	21,480	21,239	22,425
2004	20,918	21,031	21,233	21,622	23,030	24,698	25,566	24,386	22,987	22,205	21,807	21,552	22,586
2005	21,183	21,457	21,864	22,522	23,939	25,768							

Table 1.60

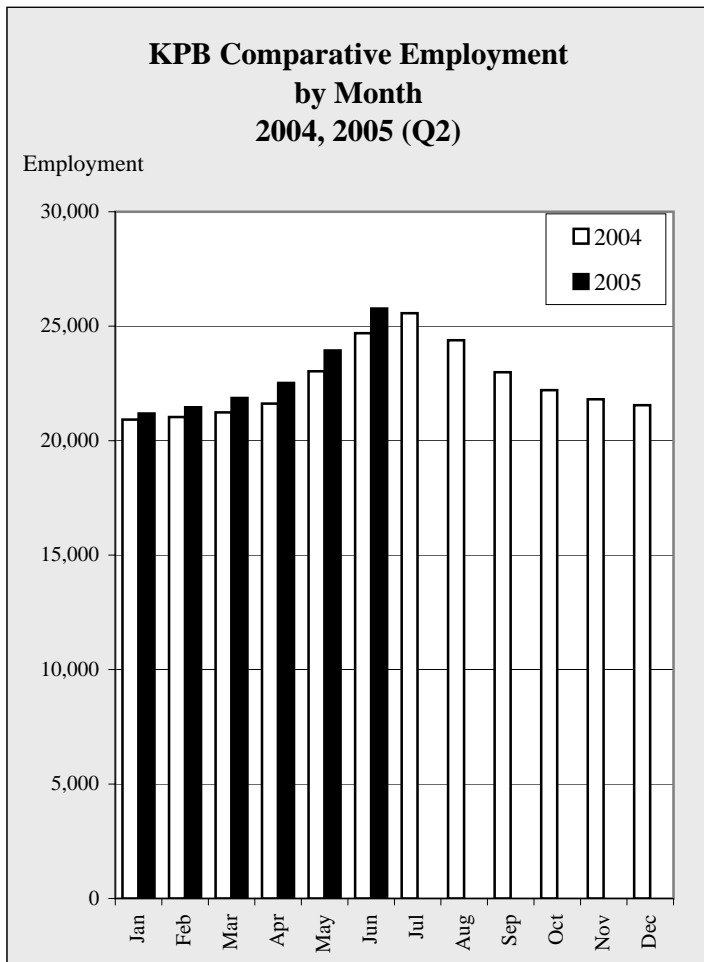

Chart 1.71

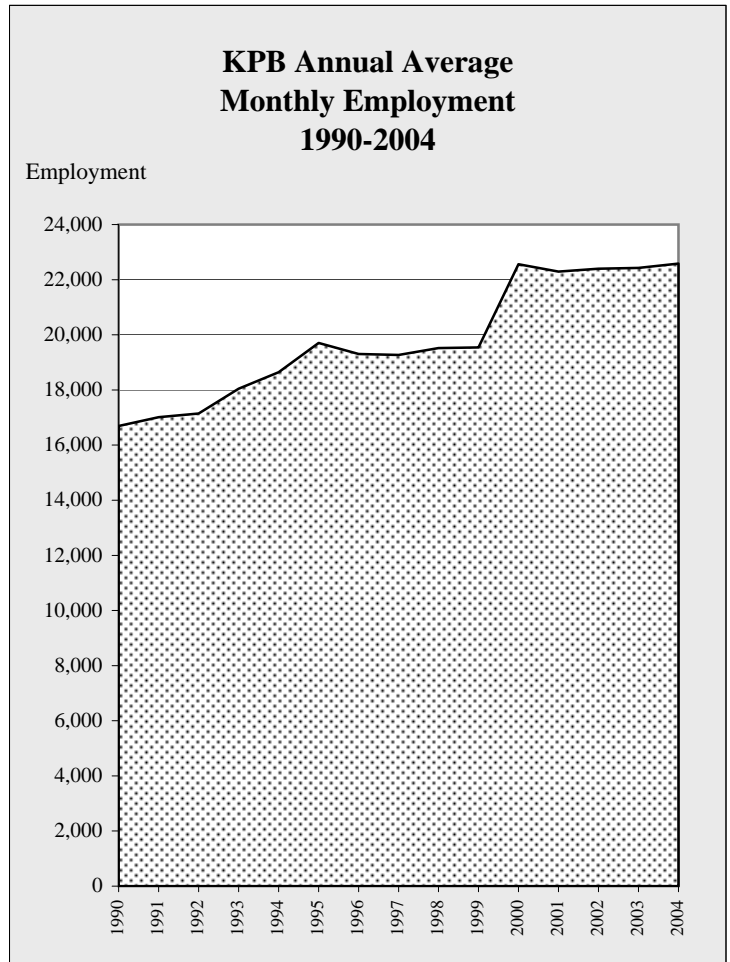

Chart 1.72

# KPB Population

## Census 2000

KPB population trends are determined through the decennial census conducted by the United States Census Bureau. A portion of Census 2000 data is presented in this section. Additional data is available through the U.S. Census Bureau or through the KPB CEDD office. Check out the U.S. Census Bureau website (<http://www.census.gov/>), which has two fantastic options, QuickFacts and AmericanFactFinder.

Census data is collected for two types of area, incorporated cities and Census Designated Places (CDP). Incorporated cities within the KPB include Homer, Kachemak City, Kenai, Seldovia, Seward and Soldotna. To be classified as a CDP, there are no specific boundaries but rather geographic features such as rivers, roads, or ridges. Certain characteristics must be present, including:

- \* A sense of community;
- \* A population of 25 or more; and
- \* It must have been recognized as possibly fitting the criteria four years prior to the census as planning began.

The Census Bureau considers an incorporated city with a population greater than 2,500 to be urban, of which there are four in the KPB: Homer, Kenai, Seward and Soldotna. As of Census 2000 Kenai is ranked 6th largest in Alaska, Homer ranks 14th, and Soldotna is the 15th largest Alaskan city.

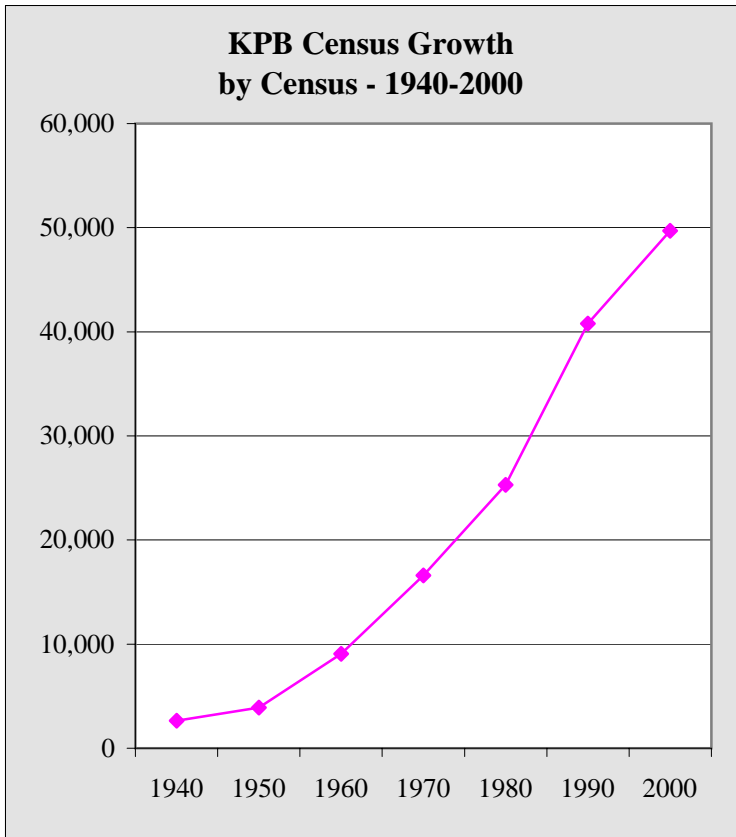

Chart 1.73

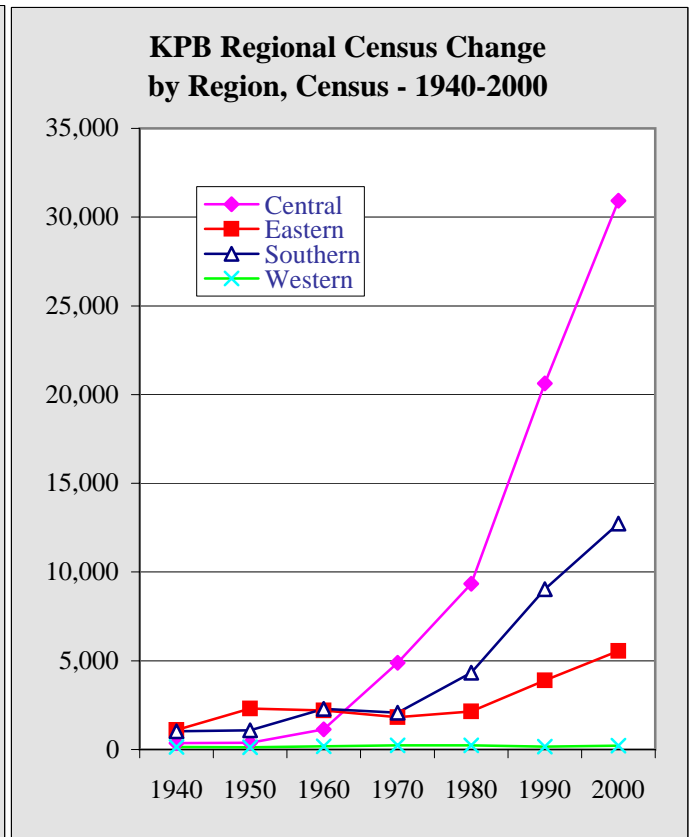

Chart 1.74

# KPB Population

<b>KPB Census by Community/CDP - 1940-2000</b>									
KPB Community	Region	1940	1950	1960	1970	1980	1990	2000	
Anchor Point	S	20	65	171	102	226	866	1,845	
Bear Creek	E	0	0	0	0	0	580	1,748	
Beluga	W	New CDP - Census 2000							32
Clam Gulch	C	0	0	0	47	50	79	173	
Cohoe	C	0	0	122	0	0	508	1,168	
Cooper Landing	E	0	60	88	31	116	243	369	
Crown Point	E	0	0	0	0	0	62	75	
Diamond Ridge	S	New						1,802	
Fox River	S	0	0	0	0	0	382	616	
Fritz Creek	S	0	0	0	27	302	1,426	1,603	
Funny River	C	New CDP - Census 2000							636
Halibut Cove	S	0	0	25	44	47	78	35	
Happy Valley	S	0	0	0	0	0	309	489	
Homer	S	325	307	1,247	1,083	2,209	3,660	3,946	
Hope	E	71	63	44	51	103	161	137	
Jakolof Bay	S	Deleted - Census 2000					36	28	Deleted
Kachemak	S	0	0	0	76	403	365	431	
Kalifornsky	C	0	0	0	0	92	285	5,846	
Kasilof	C	62	62	89	71	201	383	471	
Kenai	C	303	321	778	3,533	4,324	6,327	6,942	
Lowell Point	E	New CDP - Census 2000							92
Miller Landing	S	New CDP - Census 2000							74
Moose Pass	E	84	70	136	53	76	81	206	
Nanwalek	S	48	75	78	58	124	158	177	
Nikiski	C		0	0	0	1,109	2,743	4,327	
Nikolaevsk	S	0	0	0	0	0	371	345	
Nililchik	S	132	97	169	134	341	456	772	
Port Graham	S	93	92	139	107	161	166	171	
Primrose	E	0	0	0	0	0	63	93	
Ridgeway	C	0	0	0	0	0	2,018	1,932	
Salamatof	C	0	0	0	0	334	999	954	
Seldovia Village	S						143	144	
Seldovia City	S	410	437	460	437	479	316	286	
Seward	E	949	2,114	1,891	1,587	1,843	2,699	2,830	
Soldotna	C	0	0	32	1,202	2,320	3,482	3,759	
Sterling	C	0	0	115	30	919	3,802	4,705	
Sunrise	C	New CDP - Census 2000							18
Tyonek	W	136	132	187	232	239	154	193	
Remainder of census area	E		946	3,282	7,681	16,116	7,409	249	
Kenai Peninsula Borough		2,633	4,831	9,053	16,586	25,282	40,486	49,691	

Table 1.61

# KPB Population

<b>KPB CDP's Population Estimates - 2000 - 2004</b>						
KPB Community	2000 Census	June 1 Estimate (Subject to Annual Revision)				Annual Change
		2001	2002	2003	2004	
Anchor Point	1,845	1,809	1,784	1,812	1,792	-1.1%
Bear Creek	1,748	1,836	1,832	1,835	1,897	3.4%
Beluga	32	24	25	27	26	-3.7%
Clam Gulch	173	168	173	176	164	-6.8%
Cohoe	1,168	1,175	1,209	1,206	1,312	8.8%
Cooper Landing	369	391	372	358	351	-2.0%
Crown Point	75	89	88	78	89	14.1%
Diamond Ridge*	1,802	1,812	404	306	761	148.7%
Fox River	616	594	574	572	587	2.6%
Fritz Creek	1,603	1,662	1,735	1,744	1,732	-0.7%
Funny River	636	624	688	707	727	2.8%
Halibut Cove	35	29	28	27	26	-3.7%
Happy Valley	489	505	521	505	525	4.0%
Homer*	3,946	4,065	5,527	5,865	5,332	-9.1%
Hope	137	145	152	161	165	2.5%
Kachemak	431	426	433	478	475	-0.6%
Kalifornsky	5,846	6,011	6,153	6,249	6,617	5.9%
Kasilof	471	451	504	568	473	-16.7%
Kenai	6,942	6,870	7,071	7,123	6,809	-4.4%
Lowell Point	92	96	108	89	74	-16.9%
Miller Landing*	74	70				
Moose Pass	206	206	217	221	220	-0.5%
Nanwalek	177	184	219	214	203	-5.1%
Nikiski	4,327	4,362	4,360	4,356	4,279	-1.8%
Nikolaevsk	345	345	331	312	306	-1.9%
Ninilchik	772	758	760	774	783	1.2%
Port Graham	171	178	174	165	153	-7.3%
Primrose	93	98	92	86	90	4.7%
Ridgeway	1,932	1,961	1,963	2,022	2,047	1.2%
Salamatof	954	894	897	904	900	-0.4%
Seldovia**	430	435	450	431	426	-1.2%
Seldovia City**	286	285	288	279	263	-5.7%
Seldovia Village**	144	150	166	155	170	9.7%
Seward	2,830	2,759	2,754	2,745	2,540	-7.5%
Soldotna	3,759	3,791	3,856	3,992	3,767	-5.6%
Sterling	4,705	4,753	4,771	4,880	4,940	1.2%
Sunrise	18	16	14	15	19	26.7%
Tyonek	193	161	181	192	184	-4.2%
Remainder Kenai/Cook Inlet		229	188	190	181	-4.7%
Remainder Seward census sub area		23	13	13	8	-38.5%
Remainder of KPB	249					
Kenai Peninsula	49,691	50,005	50,621	51,398	50,980	-0.8%

Table 1.62

\* - Homer annexation included all of Miller Landing CDP and part of Diamond Ridge CDP. Annexation was effective March 20, 2002.

\*\* - Seldovia City plus Seldovia Village is not equal to the Seldovia CDP.

Note - All Estimates since 2000 have been revised by the State of Alaska Department of Labor and Workforce Development.

# KPB Population

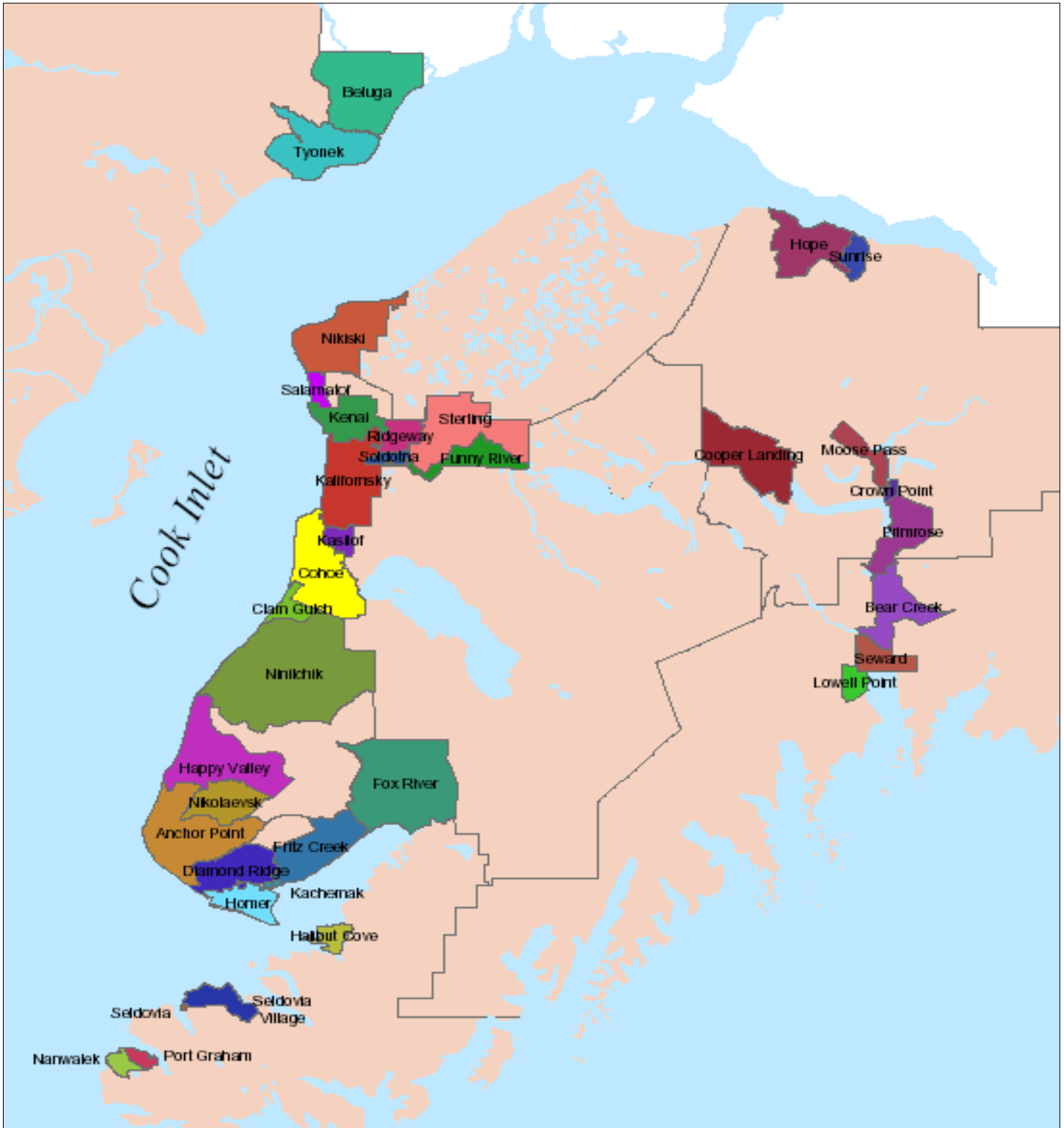

## KENAI PENINSULA BOROUGH CENSUS DESIGNATED PLACES

Chart 1.75



# KPB Population

## KPB Population by Age Group - 1990 v 2000

	1990	2000	Percent Change	Percent of Total Population
Total Population	40,802	49,691	21.8%	
Under 5 years	3,862	3,288	-14.9%	6.6%
5 to 9 years	4,059	4,024	-0.9%	8.1%
10 to 14 years	3,516	4,698	33.6%	9.5%
15 to 19 years	2,970	4,140	39.4%	8.3%
20 to 24 years	2,081	2,132	2.5%	4.3%
25 to 34 years	7,348	5,648	-23.1%	11.4%
35 to 44 years	8,234	9,074	10.2%	18.3%
45 to 54 years	4,205	8,739	107.8%	17.6%
55 to 59 years	1,376	2,632	91.3%	5.3%
60 to 64 years	1,164	1,667	43.2%	3.4%
65 to 74 years	1,489	2,361	58.6%	4.8%
75 to 84 years	419	1,077	157.0%	2.2%
85 years and over	79	211	167.1%	0.4%

Table 1.63

KPB's median age increased from 31.1 years during the 1990 census to 36.3 as of Census 2000. Alaska's median age is 32.4 years while the United States median age is 35.3 years.

KPB's 2004 population, estimated by the AK DOL&WD is estimated at 50,980, a 0.8% decrease from 2003. Estimates are based primarily on births, deaths and Permanent Fund Dividend applications.

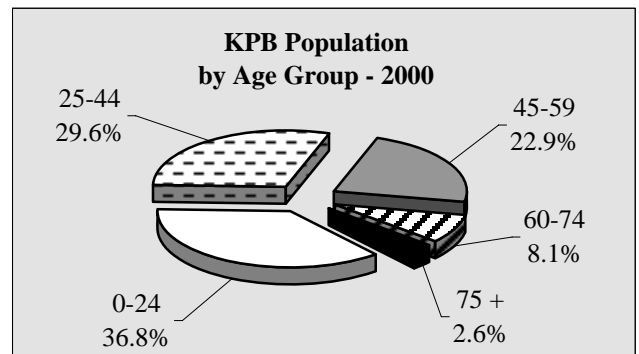

Chart 1.76

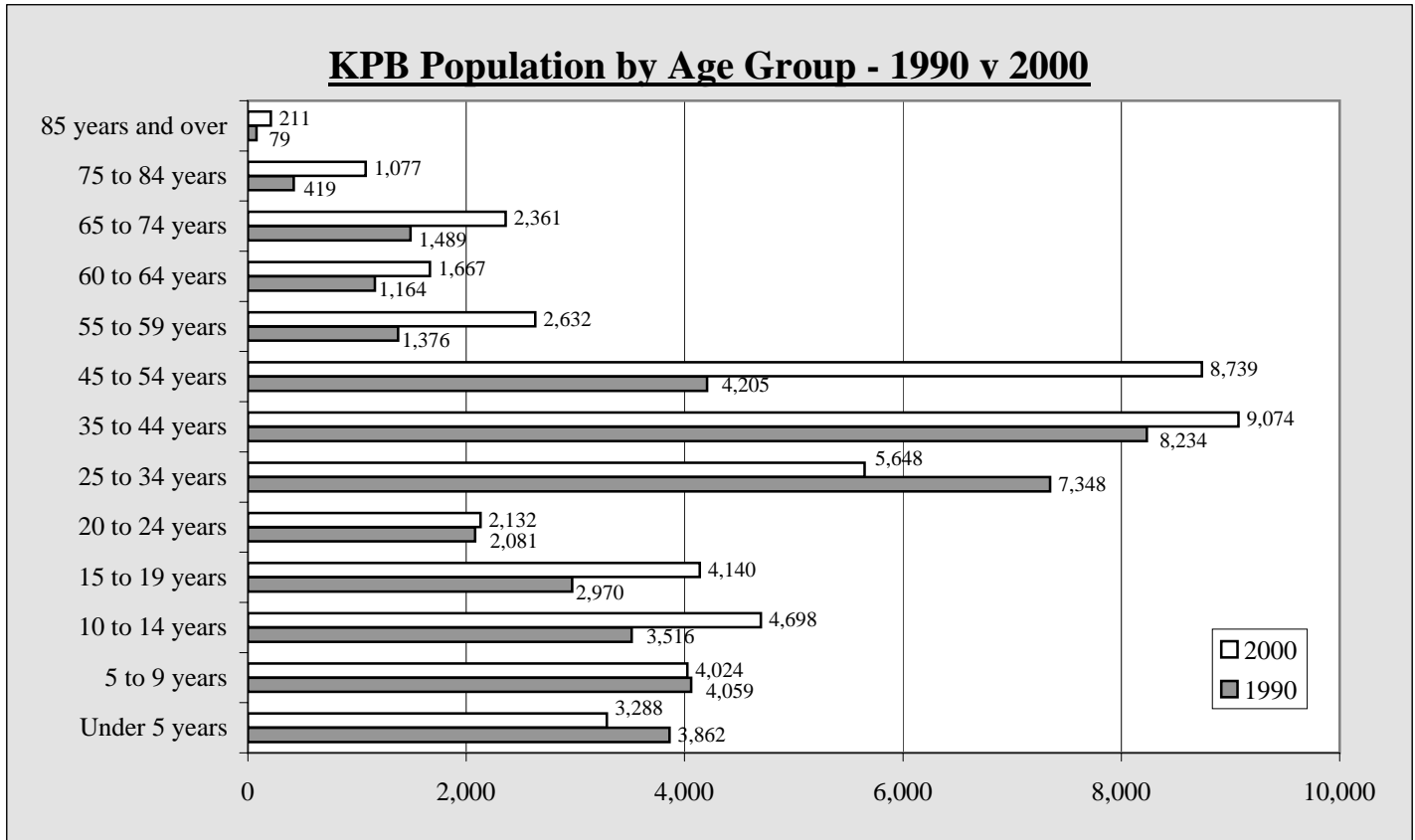

Chart 1.77

# Homer Sales

<b>Homer 2nd Quarter GROSS Sales by Industry - 1999-2005 - in \$</b>								
	1999	2000	2001	2002	2003	2004	2005	Annual Change
Ag, Forest, Fish	297,282	615,776	221,357	250,389	420,146	430,095	518,297	20.5%
Mining	0	0	1,844	3,836	0	104	15,410	14717.3%
Construction	5,877,294	11,808,767	6,727,125	7,437,731	11,071,038	5,685,550	11,383,064	100.2%
Manufacturing	4,737,214	1,939,037	1,455,193	1,790,421	1,899,935	1,807,647	1,542,572	-14.7%
Trans, Comm, Pub Util	8,239,713	8,584,067	8,926,617	10,982,097	9,778,534	5,034,111	12,073,884	139.8%
Wholesale	4,606,377	4,452,048	5,204,028	5,360,132	6,092,813	6,421,737	6,881,765	7.2%
Retail	18,330,887	19,883,252	20,975,149	24,997,009	27,557,784	30,021,416	32,195,201	7.2%
Finance, Ins, RE	1,917,870	1,686,154	1,982,111	2,046,589	2,547,744	2,619,310	2,737,927	4.5%
Services	9,864,551	10,318,481	11,364,051	15,803,541	15,919,950	16,958,505	16,944,932	-0.1%
Government	53,871,188	59,287,582	56,857,475	68,671,745	75,287,944	68,978,475	84,293,052	22.2%
Annual Change		10.1%	-4.1%	20.8%	9.6%	-8.4%	22.2%	

Table 2.1

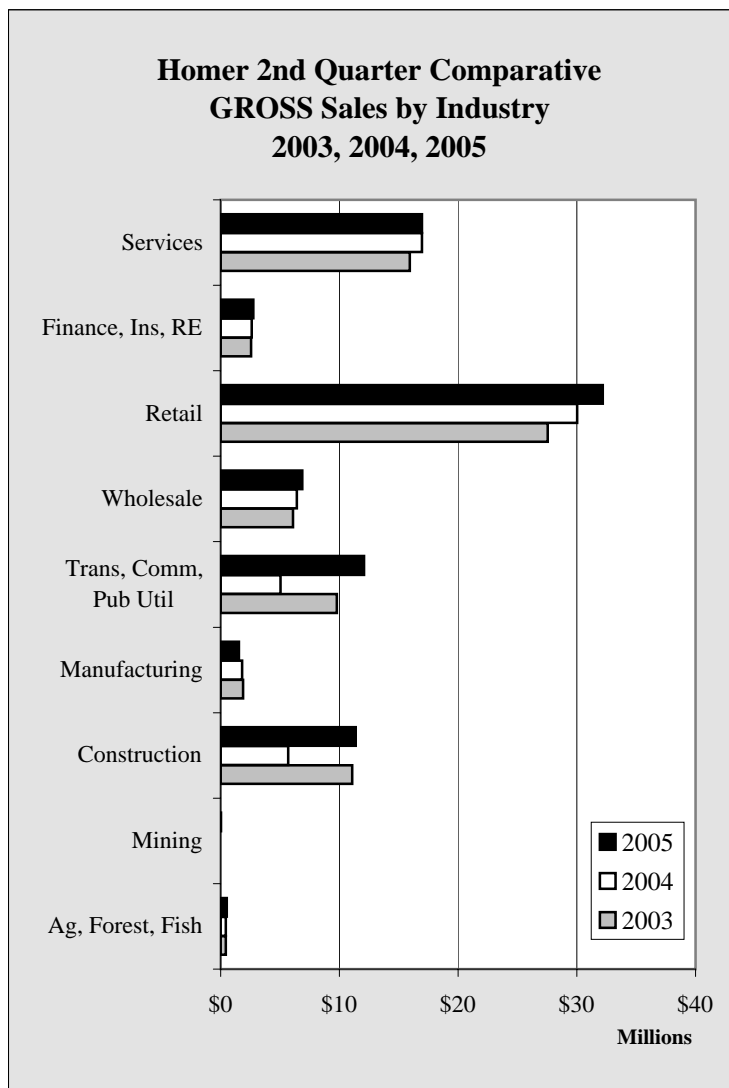

Chart 2.1

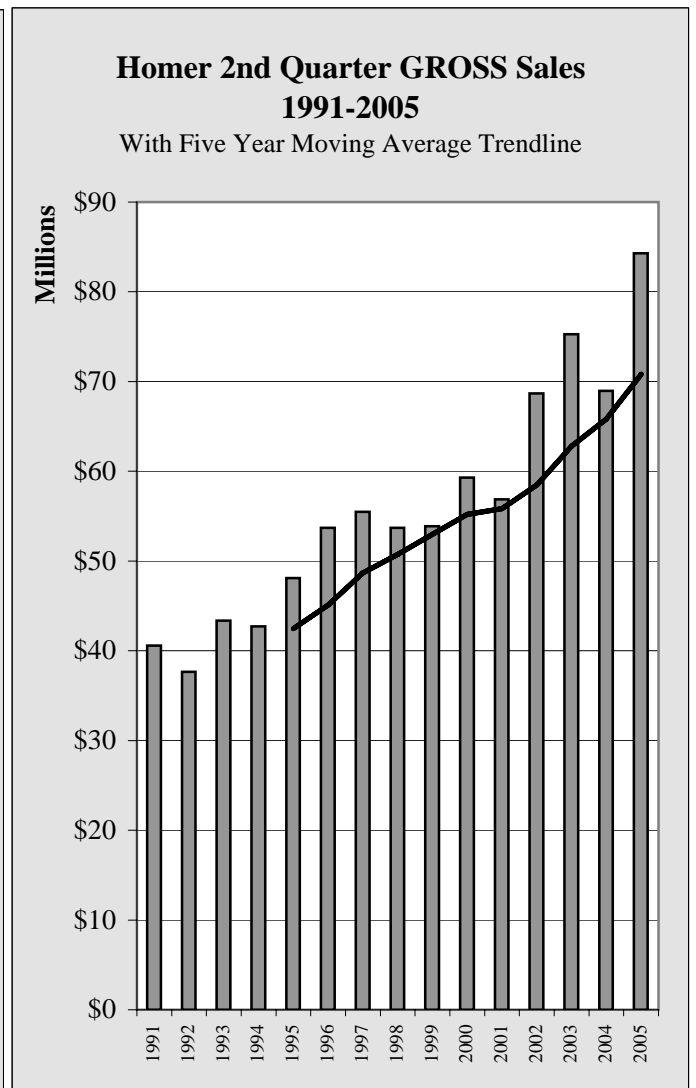

Chart 2.2

Annexation of an area increasing the size of Homer by approximately 28% was effective April 1, 2002.

# Homer Sales

<b>Homer 2nd Quarter TAXABLE Sales by Industry - 1999-2005 - in \$</b>								
	1999	2000	2001	2002	2003	2004	2005	Annual Change
Ag, Forest, Fish	119,513	134,398	146,035	166,982	212,539	247,630	236,684	-4.4%
Mining	0	0	1,549	1,955	0	104	0	NA
Construction	243,633	223,397	217,384	266,994	312,650	319,319	269,560	-15.6%
Manufacturing	629,296	605,159	528,377	557,095	532,466	608,034	513,370	-15.6%
Trans, Comm, Pub Util	2,572,659	2,607,929	2,581,062	2,873,043	3,212,975	3,248,197	2,884,374	-11.2%
Wholesale	2,136,082	2,427,493	2,538,512	2,518,226	2,966,252	3,320,836	3,363,267	1.3%
Retail	13,815,206	14,899,354	15,861,254	18,247,283	19,762,887	21,267,878	22,507,854	5.8%
Finance, Ins, RE	751,660	814,036	923,819	1,005,737	1,062,609	1,153,322	1,069,762	-7.2%
Services	6,670,510	7,086,106	7,393,485	8,630,174	8,976,090	9,483,204	9,393,640	-0.9%
Government	26,938,559	28,797,872	30,191,477	34,267,489	37,038,468	39,648,524	40,238,511	1.5%
Annual Change		6.9%	4.8%	13.5%	8.1%	7.0%	1.5%	

Table 2.2

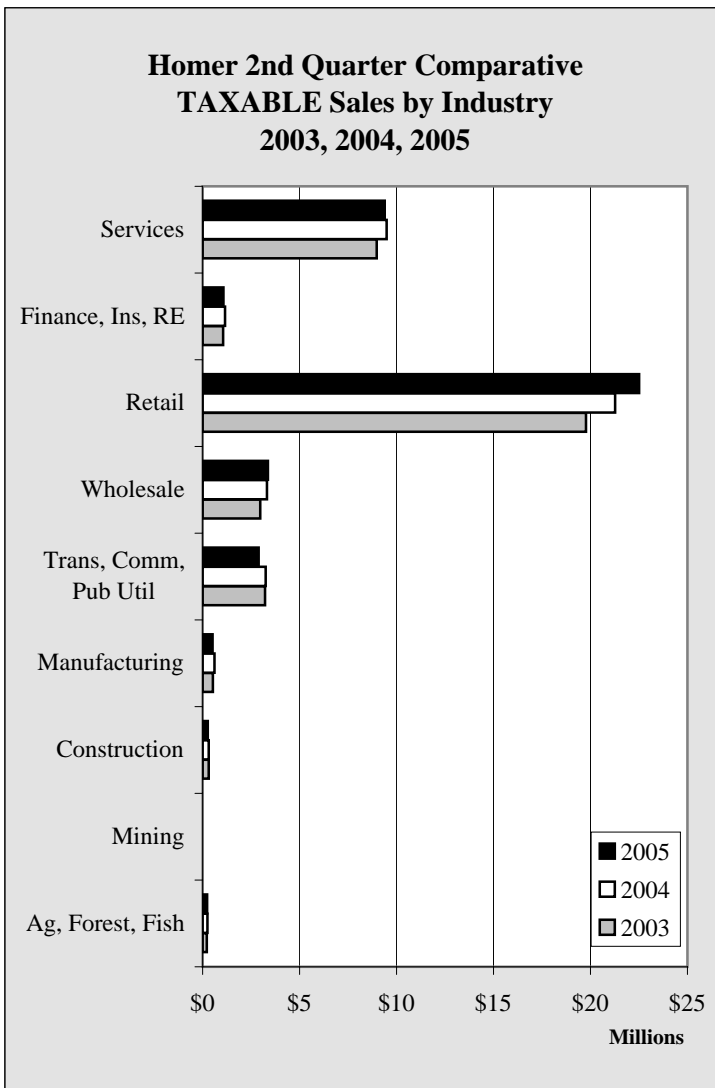

Chart 2.3

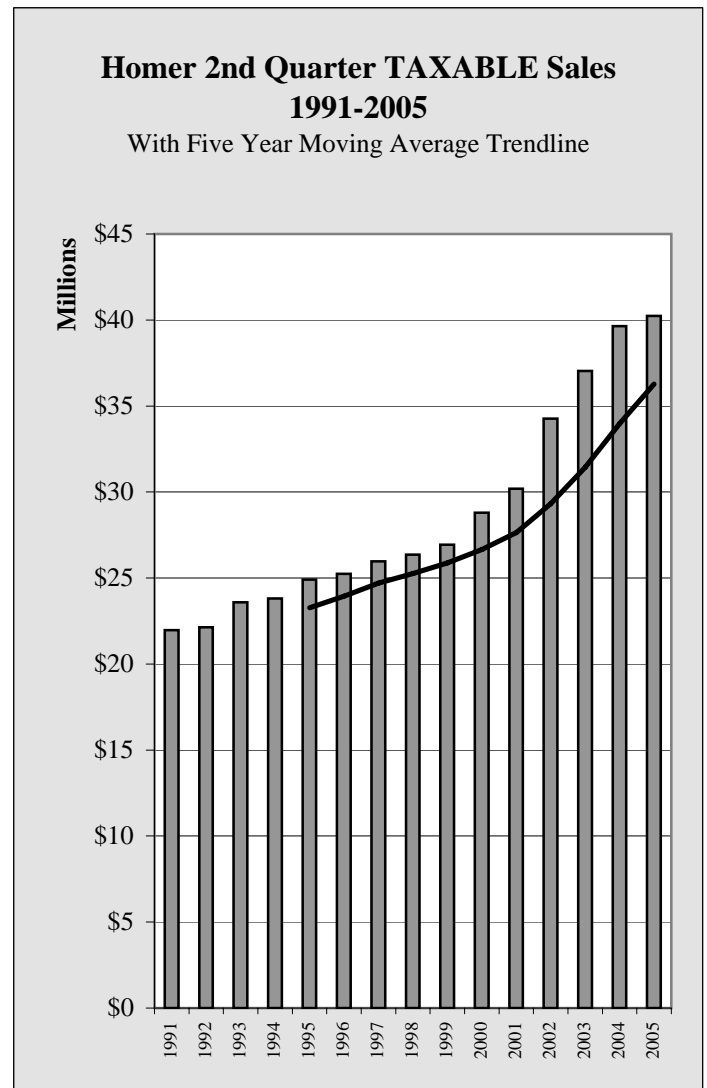

Chart 2.4

Annexation of an area increasing the size of Homer by approximately 28% was effective April 1, 2002.

# Homer Sales

<b>Homer YTD 6/30 GROSS Sales by Industry - 1999-2005 - in \$</b>								
	1999	2000	2001	2002	2003	2004	2005	Annual Change
Ag, Forest, Fish	391,347	790,276	381,823	385,101	669,479	659,447	790,574	19.9%
Mining	195	0	10,981	5,199	0	360	15,410	NA
Construction	11,889,063	19,103,934	14,850,565	15,868,655	20,866,561	10,011,515	16,637,769	66.2%
Manufacturing	8,247,806	3,692,870	2,780,586	3,044,255	3,217,571	2,923,790	2,317,787	-20.7%
Trans, Comm, Pub Util	16,553,120	16,347,045	17,319,824	20,766,385	19,239,191	15,011,559	22,934,848	52.8%
Wholesale	8,743,545	7,629,651	8,704,682	8,718,142	10,137,408	10,543,909	11,362,217	7.8%
Retail	29,615,149	32,088,649	33,901,273	38,764,881	44,666,489	48,248,833	51,994,338	7.8%
Finance, Ins, RE	3,874,889	3,133,715	3,387,314	3,574,314	4,537,669	4,866,668	4,811,448	-1.1%
Services	14,109,722	14,956,609	16,365,405	21,809,759	23,181,852	24,853,313	25,317,014	1.9%
Government	93,424,836	97,742,749	97,702,453	112,936,691	126,516,220	117,119,394	136,181,405	16.3%
Annual Change		4.6%	0.0%	15.6%	12.0%	-7.4%	16.3%	

Table 2.3

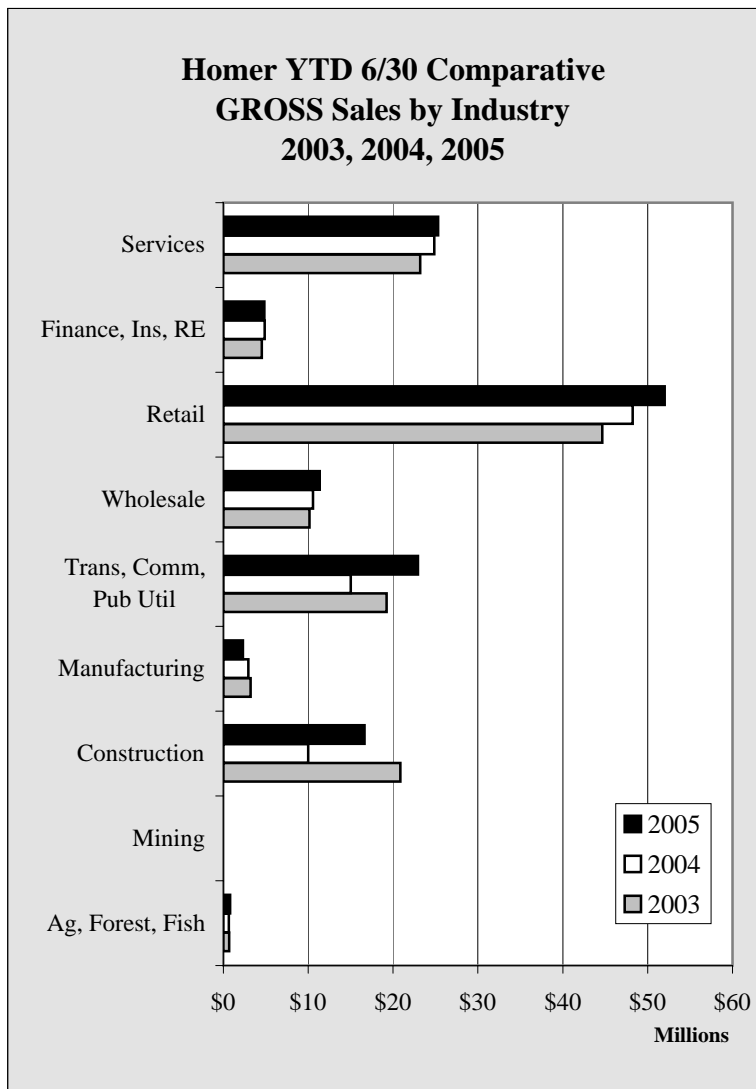

Chart 2.5

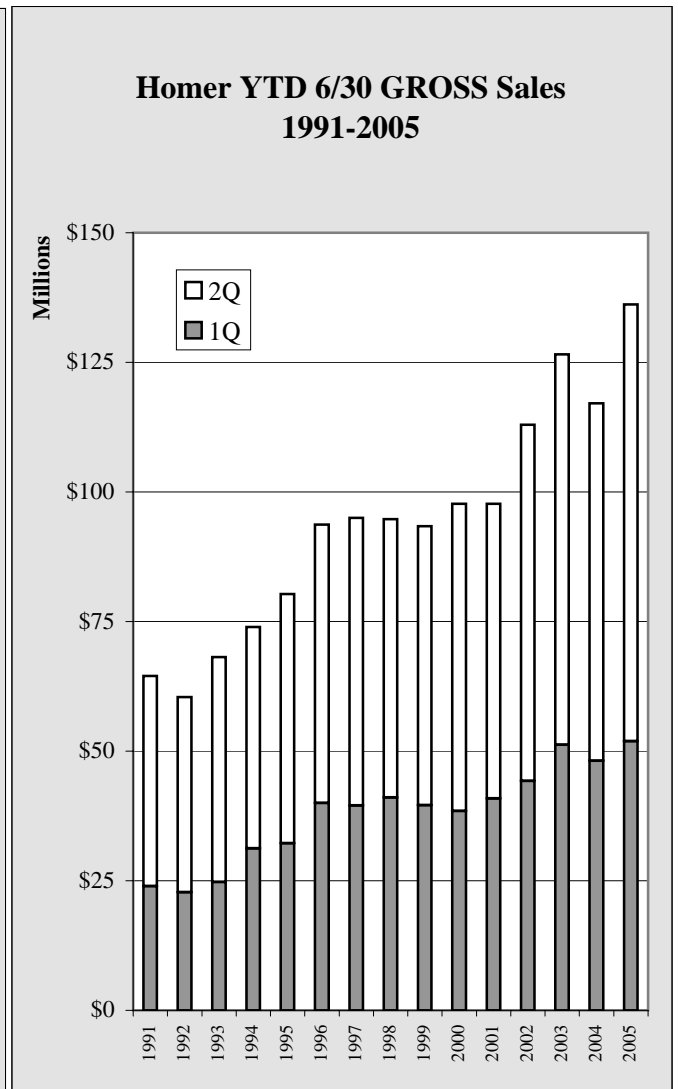

Chart 2.6

Annexation of an area increasing the size of Homer by approximately 28% was effective April 1, 2002.

# Homer Sales

Homer YTD 6/30 TAXABLE Sales by Industry - 1999-2005 - in \$								
	1999	2000	2001	2002	2003	2004	2005	Annual Change
Ag, Forest, Fish	199,378	242,979	254,324	284,255	348,273	405,587	425,966	5.0%
Mining	195	0	3,189	2,665	0	104	0	NA
Construction	425,666	438,319	396,176	504,628	555,996	596,204	507,202	-14.9%
Manufacturing	974,329	957,392	854,252	820,347	809,992	913,385	746,149	-18.3%
Trans, Comm, Pub Util	4,873,456	4,789,944	4,710,712	5,098,165	6,103,590	6,054,703	5,704,488	-5.8%
Wholesale	3,646,992	4,077,191	4,230,347	4,180,681	4,977,060	5,555,215	5,549,183	-0.1%
Retail	22,630,880	24,087,192	25,410,773	28,347,971	31,761,592	34,246,636	35,996,898	5.1%
Finance, Ins, RE	1,412,900	1,489,607	1,615,853	1,774,305	1,962,755	2,043,875	1,922,847	-5.9%
Services	9,413,230	10,043,108	10,481,055	11,951,576	12,975,492	13,657,341	13,721,957	0.5%
Government	0	0	0	0	0	394	0	-100.0%
Total	43,577,026	46,125,732	47,956,681	52,964,593	59,494,750	63,473,050	64,574,690	1.7%
Annual Change		5.8%	4.0%	10.4%	12.3%	6.7%	1.7%	

Table 2.4

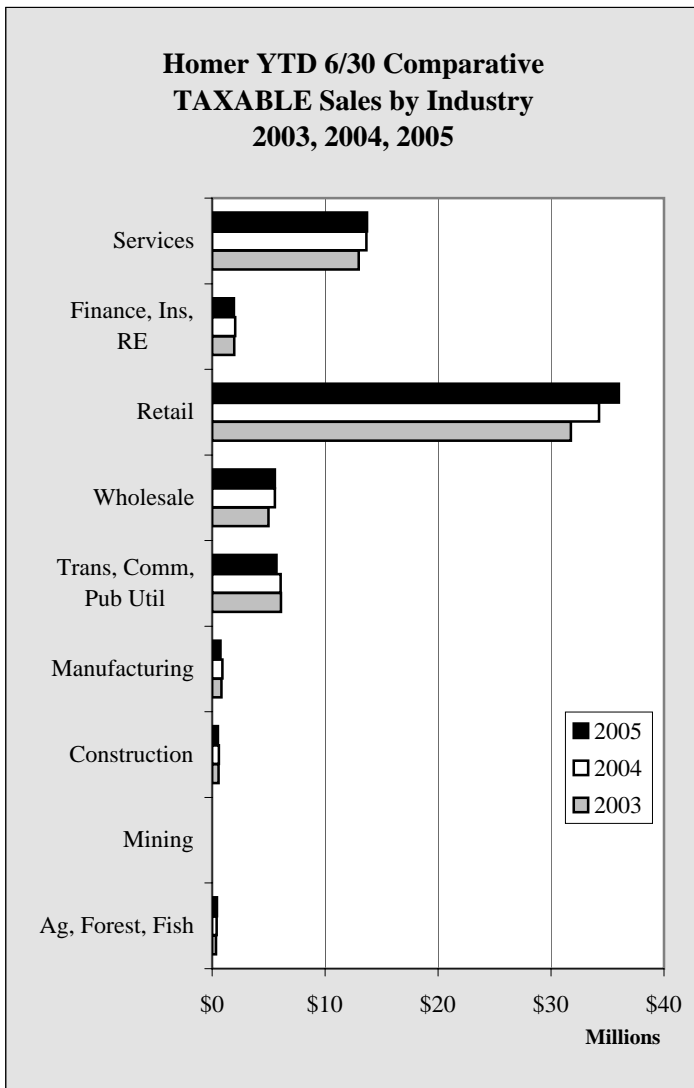

Chart 2.7

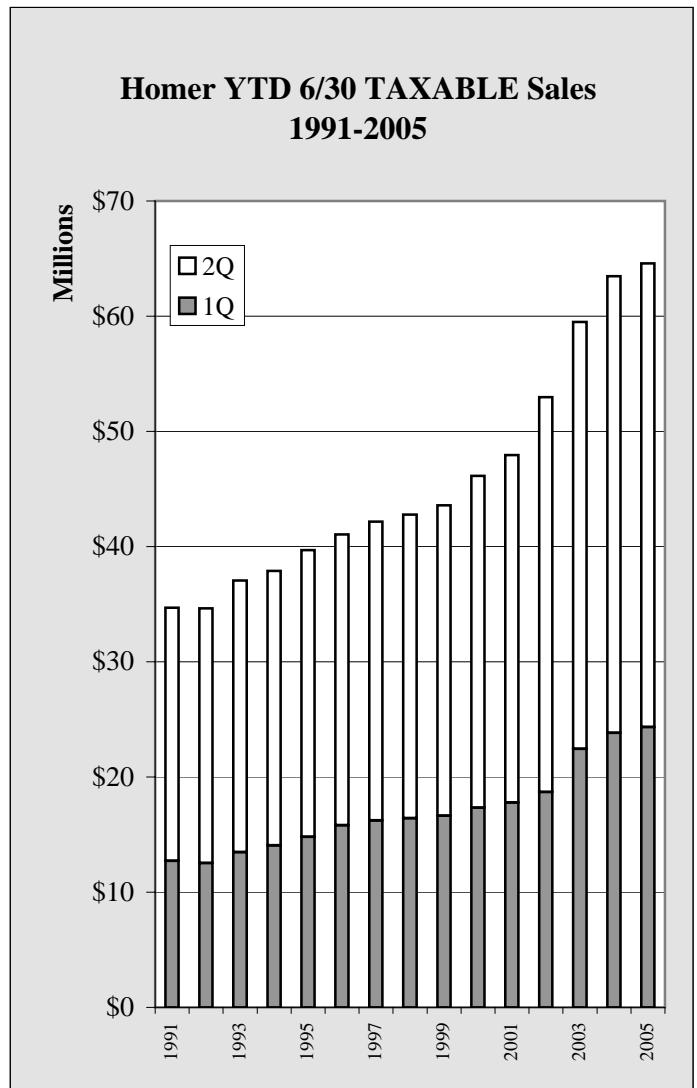

Chart 2.8

Annexation of an area increasing the size of Homer by approximately 28% was effective April 1, 2002.

# Homer Sales

**Homer Annual GROSS Sales by Industry - 1998-2004 - in \$**

	1998	1999	2000	2001	2002	2003	2004	Annual Change
Ag, Forest, Fish	1,231,758	1,132,289	1,763,891	931,926	1,013,352	1,592,413	1,520,013	-4.5%
Mining	130	13,595	24,864	15,819	8,582	1,283	151,171	11682.6%
Construction	37,787,332	27,642,104	42,378,954	40,149,696	45,829,436	41,984,440	32,449,476	-22.7%
Manufacturing	19,649,701	16,450,883	6,761,789	6,482,895	6,590,594	6,755,907	5,657,729	-16.3%
Trans, Comm, Pub Util	34,491,856	33,675,536	34,493,682	40,495,596	42,137,752	39,996,686	40,511,899	1.3%
Wholesale	14,672,913	17,513,809	16,999,389	18,602,483	19,915,750	22,075,685	27,077,381	22.7%
Retail	64,712,270	66,221,369	71,465,479	75,795,576	88,239,711	97,820,663	105,673,533	8.0%
Finance, Ins, RE	8,574,588	7,448,936	6,682,678	7,544,432	8,453,334	9,936,484	11,521,431	16.0%
Services	31,322,069	33,743,954	35,410,998	39,685,084	51,007,289	53,867,042	59,119,492	9.8%
Government	0	0	0	0	0	263	394	49.8%
Total	212,442,617	203,842,475	215,981,724	229,703,507	263,195,800	274,030,866	283,682,519	3.5%
Annual Change		-4.0%	6.0%	6.4%	14.6%	4.1%	3.5%	

Table 2.5

**Homer Annual Comparative  
GROSS Sales by Industry  
2002, 2003, 2004**

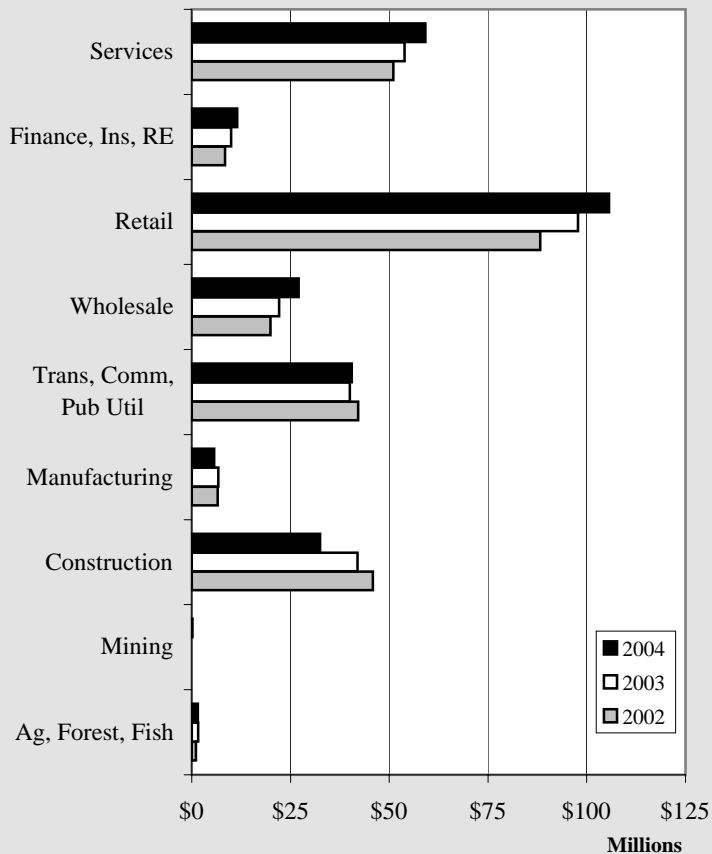

Chart 2.9

Annexation of an area increasing the size of Homer by approximately 28% was effective April 1, 2002.

**Homer Annual GROSS Sales  
1991-2004**

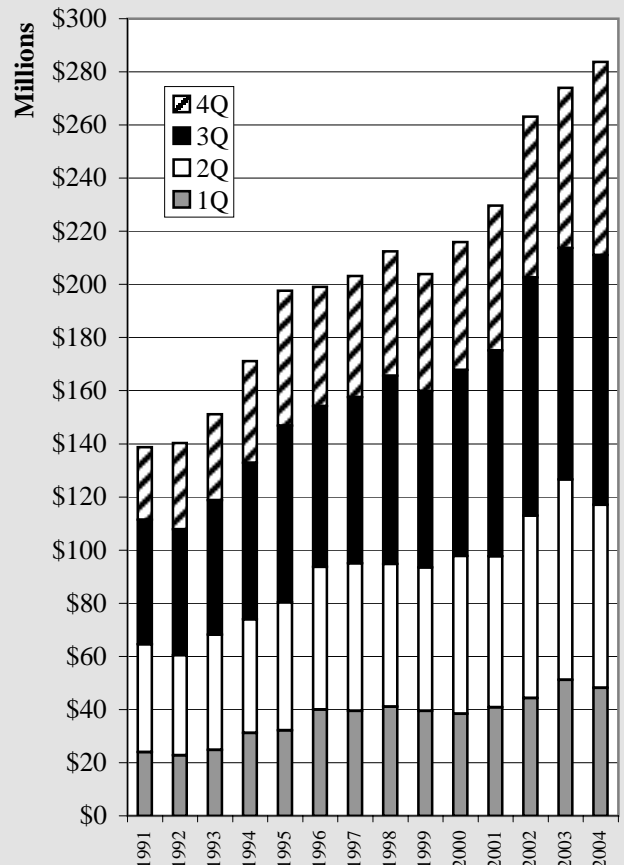

Chart 2.10

# Homer Sales

<b>Homer Annual TAXABLE Sales by Industry - 1998-2004 - in \$</b>								
	1998	1999	2000	2001	2002	2003	2004	Annual Change
Ag, Forest, Fish	626,058	461,892	519,595	577,360	641,294	773,421	912,356	18.0%
Mining	130	195	1,104	5,993	2,665	347	104	-70.0%
Construction	820,655	891,101	891,188	940,211	1,125,715	1,208,909	1,182,169	-2.2%
Manufacturing	2,087,103	2,084,079	2,045,894	1,769,534	1,822,345	1,848,166	1,857,314	0.5%
Trans, Comm, Pub Util	9,578,082	10,137,988	10,110,454	10,200,922	11,698,087	12,717,059	12,827,427	0.9%
Wholesale	7,485,103	8,034,552	8,633,107	8,953,325	8,876,648	10,611,085	11,951,881	12.6%
Retail	48,994,370	50,357,048	53,206,860	56,027,806	63,864,887	69,823,667	74,188,687	6.3%
Finance, Ins, RE	2,814,367	2,949,461	3,147,793	3,460,712	3,890,685	4,074,657	4,455,978	9.4%
Services	22,035,474	23,232,422	24,634,121	25,375,676	29,345,792	30,631,264	32,626,542	6.5%
Government	0	0	0	0	0	263	394	49.8%
<b>Total</b>	<b>94,441,342</b>	<b>98,148,738</b>	<b>103,190,116</b>	<b>107,311,539</b>	<b>121,268,118</b>	<b>131,688,838</b>	<b>140,002,852</b>	<b>6.3%</b>
Annual Change		3.9%	5.1%	4.0%	13.0%	8.6%	6.3%	

Table 2.6

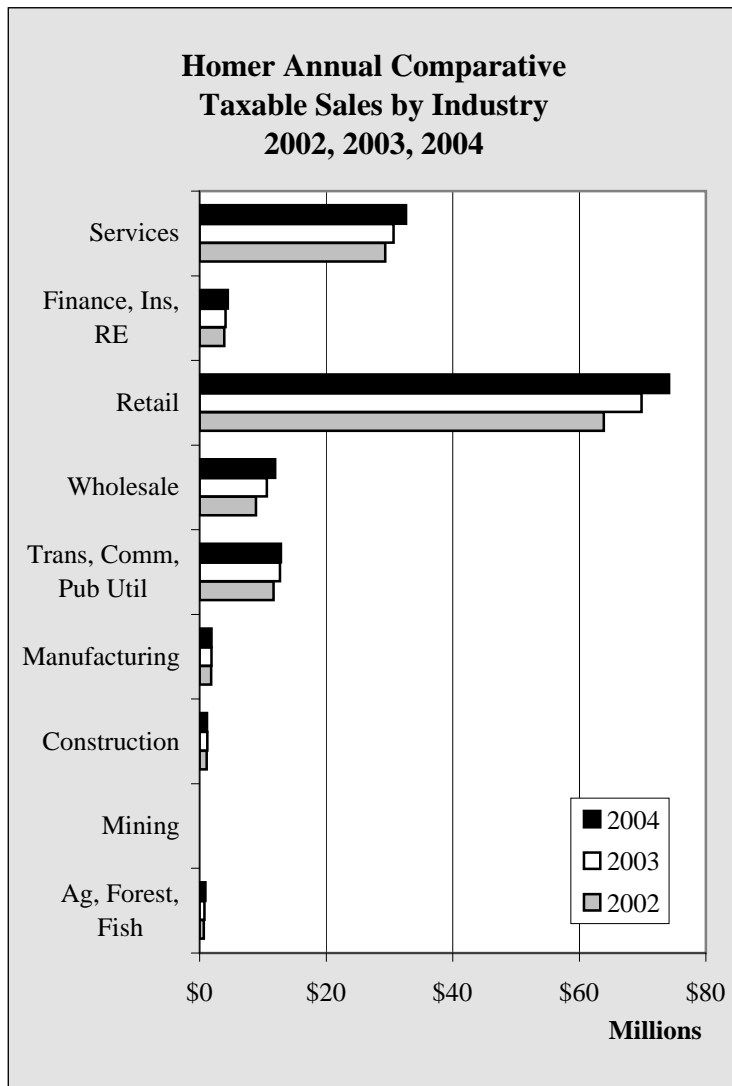

Chart 2.11

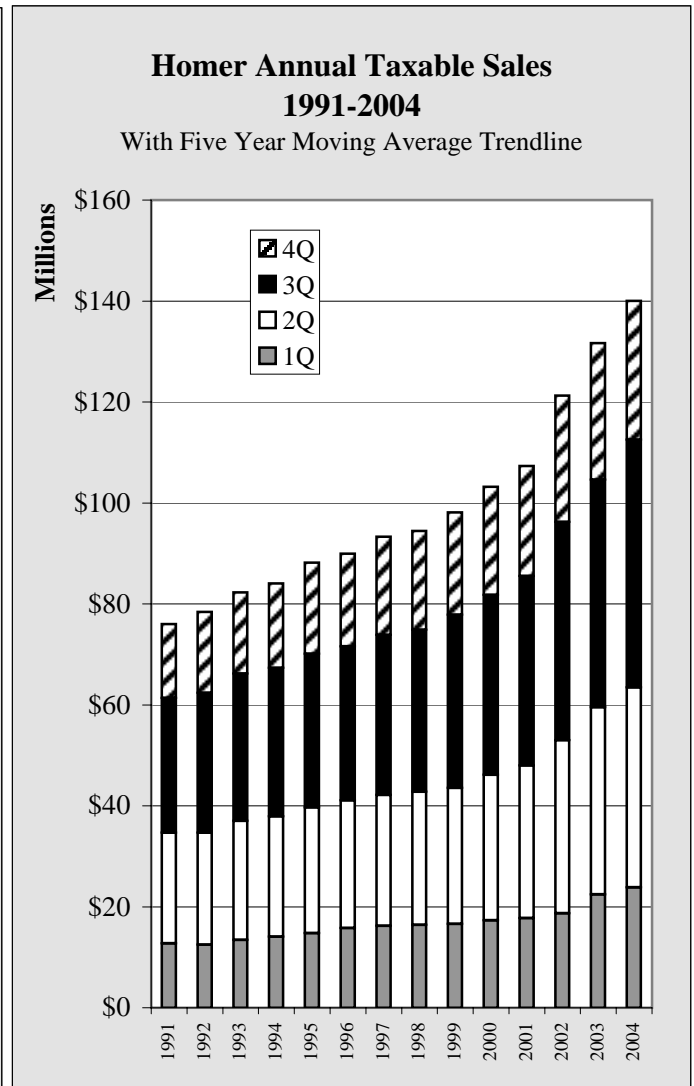

Chart 2.12

Annexation of an area increasing the size of Homer by approximately 28% was effective April 1, 2002.

# Homer Sales

<b>Homer GROSS Sales by Industry by Quarter - 2002-2005 - in \$</b>					
	1st Quarter	2nd Quarter	3rd Quarter	4th Quarter	Total
<b>2002</b>					
Ag, Forestry, Fishing	134,712	250,389	358,911	269,340	1,013,352
Mining	1,363	3,836	3,383	0	8,582
Construction	8,430,924	7,437,731	15,972,357	13,988,424	45,829,436
Manufacturing	1,253,834	1,790,421	2,153,455	1,392,884	6,590,594
Trans, Comm, Pub Util	9,784,288	10,982,097	11,525,181	9,846,186	42,137,752
Wholesale	3,358,010	5,360,132	6,595,619	4,601,989	19,915,750
Retail	13,767,872	24,997,009	28,967,558	20,507,272	88,239,711
Finance, Ins, RE	1,527,725	2,046,589	2,696,231	2,182,789	8,453,334
Services	6,006,218	15,803,541	21,417,906	7,779,624	51,007,289
Government	0	0	0	0	0
<b>Total</b>	<b>44,264,946</b>	<b>68,671,745</b>	<b>89,690,601</b>	<b>60,568,508</b>	<b>263,195,800</b>
<b>2003</b>					
Ag, Forestry, Fishing	249,333	420,146	485,712	437,222	1,592,413
Mining	0	0	448	835	1,283
Construction	9,795,523	11,071,038	11,629,038	9,488,841	41,984,440
Manufacturing	1,317,636	1,899,935	2,019,280	1,519,056	6,755,907
Trans, Comm, Pub Util	9,460,657	9,778,534	11,335,988	9,421,507	39,996,686
Wholesale	4,044,595	6,092,813	6,629,440	5,308,837	22,075,685
Retail	17,108,705	27,557,784	31,205,896	21,948,278	97,820,663
Finance, Ins, RE	1,989,925	2,547,744	2,825,493	2,573,322	9,936,484
Services	7,261,902	15,919,950	21,057,005	9,628,185	53,867,042
Government	0	0	0	263	263
<b>Total</b>	<b>51,228,276</b>	<b>75,287,944</b>	<b>87,188,300</b>	<b>60,326,346</b>	<b>274,030,866</b>
<b>2004</b>					
Ag, Forestry, Fishing	229,352	430,095	512,372	348,194	1,520,013
Mining	256	104	695	150,116	151,171
Construction	4,325,965	5,685,550	9,736,168	12,701,793	32,449,476
Manufacturing	1,116,143	1,807,647	1,752,124	981,815	5,657,729
Trans, Comm, Pub Util	9,977,448	5,034,111	13,967,425	11,532,915	40,511,899
Wholesale	4,122,172	6,421,737	7,325,763	9,207,709	27,077,381
Retail	18,227,417	30,021,416	34,477,697	22,947,003	105,673,533
Finance, Ins, RE	2,247,358	2,619,310	3,341,741	3,313,022	11,521,431
Services	7,894,808	16,958,505	22,822,095	11,444,084	59,119,492
Government	394	0	0	0	394
<b>Total</b>	<b>48,141,313</b>	<b>68,978,475</b>	<b>93,936,080</b>	<b>72,626,651</b>	<b>283,682,519</b>
<b>2005</b>					
					<b>Year to Date</b>
Ag, Forestry, Fishing	272,277	518,297			790,574
Mining	0	15,410			15,410
Construction	5,254,705	11,383,064			16,637,769
Manufacturing	775,215	1,542,572			2,317,787
Trans, Comm, Pub Util	10,860,964	12,073,884			22,934,848
Wholesale	4,480,452	6,881,765			11,362,217
Retail	19,799,137	32,195,201			51,994,338
Finance, Ins, RE	2,073,521	2,737,927			4,811,448
Services	8,372,082	16,944,932			25,317,014
Government	0	0			0
<b>Total</b>	<b>51,888,353</b>	<b>84,293,052</b>	<b>0</b>	<b>0</b>	<b>136,181,405</b>

Table 2.7



# Homer Sales

<b>Homer TAXABLE Sales by Industry by Quarter - 2002-2005 - in \$</b>					
	1st Quarter	2nd Quarter	3rd Quarter	4th Quarter	Total
<b>2002</b>					
Ag, Forestry, Fishing	117,273	166,982	195,905	161,134	641,294
Mining	710	1,955	0	0	2,665
Construction	237,634	266,994	324,412	296,675	1,125,715
Manufacturing	263,252	557,095	597,126	404,872	1,822,345
Trans, Comm, Pub Util	2,225,122	2,873,043	3,752,729	2,847,193	11,698,087
Wholesale	1,662,455	2,518,226	2,928,198	1,767,769	8,876,648
Retail	10,100,688	18,247,283	21,308,629	14,208,287	63,864,887
Finance, Ins, RE	768,568	1,005,737	1,165,651	950,729	3,890,685
Services	3,321,402	8,630,174	12,978,461	4,415,755	29,345,792
Government	0	0	0	0	0
<b>Total</b>	<b>18,697,104</b>	<b>34,267,489</b>	<b>43,251,111</b>	<b>25,052,414</b>	<b>121,268,118</b>
<b>2003</b>					
Ag, Forestry, Fishing	135,734	212,539	250,473	174,675	773,421
Mining	0	0	0	347	347
Construction	243,346	312,650	335,295	317,618	1,208,909
Manufacturing	277,526	532,466	618,081	420,093	1,848,166
Trans, Comm, Pub Util	2,890,615	3,212,975	3,752,532	2,860,937	12,717,059
Wholesale	2,010,808	2,966,252	3,370,701	2,263,324	10,611,085
Retail	11,998,705	19,762,887	22,642,061	15,420,014	69,823,667
Finance, Ins, RE	900,146	1,062,609	1,146,791	965,111	4,074,657
Services	3,999,402	8,976,090	12,972,607	4,683,165	30,631,264
Government	0	0	0	263	263
<b>Total</b>	<b>22,456,282</b>	<b>37,038,468</b>	<b>45,088,541</b>	<b>27,105,547</b>	<b>131,688,838</b>
<b>2004</b>					
Ag, Forestry, Fishing	157,957	247,630	305,982	200,787	912,356
Mining	0	104	0	0	104
Construction	276,885	319,319	300,979	284,986	1,182,169
Manufacturing	305,351	608,034	632,048	311,881	1,857,314
Trans, Comm, Pub Util	2,806,506	3,248,197	3,909,932	2,862,792	12,827,427
Wholesale	2,234,379	3,320,836	3,998,096	2,398,570	11,951,881
Retail	12,978,758	21,267,878	24,233,534	15,708,517	74,188,687
Finance, Ins, RE	890,553	1,153,322	1,453,205	958,898	4,455,978
Services	4,174,137	9,483,204	14,194,393	4,774,808	32,626,542
Government	394	0	0	0	394
<b>Total</b>	<b>23,824,920</b>	<b>39,648,524</b>	<b>49,028,169</b>	<b>27,501,239</b>	<b>140,002,852</b>
<b>2005</b>					
					<b>Year to Date</b>
Ag, Forestry, Fishing	189,282	236,684			425,966
Mining	0	0			0
Construction	237,642	269,560			507,202
Manufacturing	232,779	513,370			746,149
Trans, Comm, Pub Util	2,820,114	2,884,374			5,704,488
Wholesale	2,185,916	3,363,267			5,549,183
Retail	13,489,044	22,507,854			35,996,898
Finance, Ins, RE	853,085	1,069,762			1,922,847
Services	4,328,317	9,393,640			13,721,957
Government	0	0			0
<b>Total</b>	<b>24,336,179</b>	<b>40,238,511</b>	<b>0</b>	<b>0</b>	<b>64,574,690</b>

Table 2.8

# Homer Construction

Homer 2nd Quarter Permit VALUES by Type - 1999-2005 - in \$								
	1999	2000	2001	2002	2003	2004	2005	Annual Change
Residential New	1,038,000	867,440	2,093,800	1,308,460	3,811,480	2,495,400	3,072,000	23.1%
Residential Alter/Add	118,000	115,000	306,440	205,400	239,060	205,730	451,000	119.2%
Commercial New	1,520,000	725,480	1,485,800	1,000,000	3,535,720	4,700,518	7,469,000	58.9%
Commercial Alter/Add	15,000	558,000	216,000	14,349	343,240	32,063	250,000	679.7%
Total	2,691,000	2,265,920	4,102,040	2,528,209	7,929,500	7,433,711	11,242,000	51.2%
Annual Change		-15.8%	81.0%	-38.4%	213.6%	-6.3%	51.2%	

Table 2.9

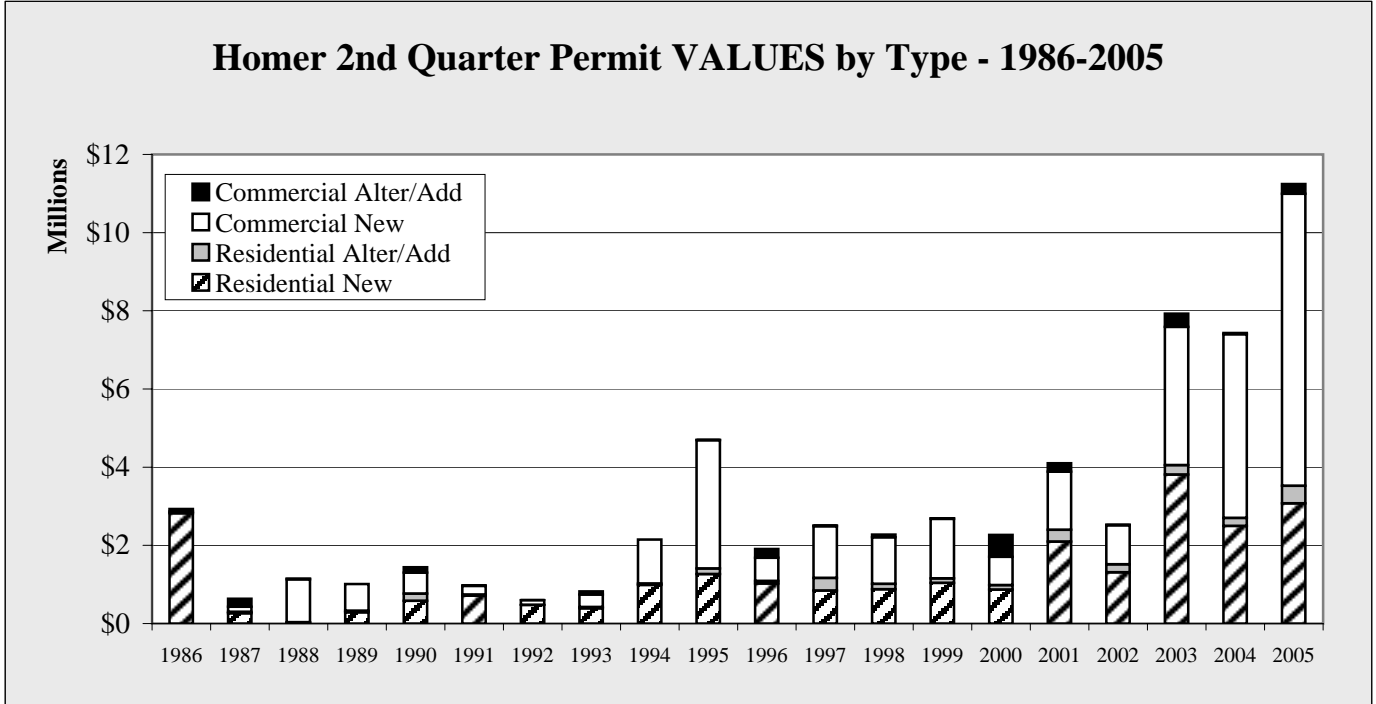

Chart 2.13

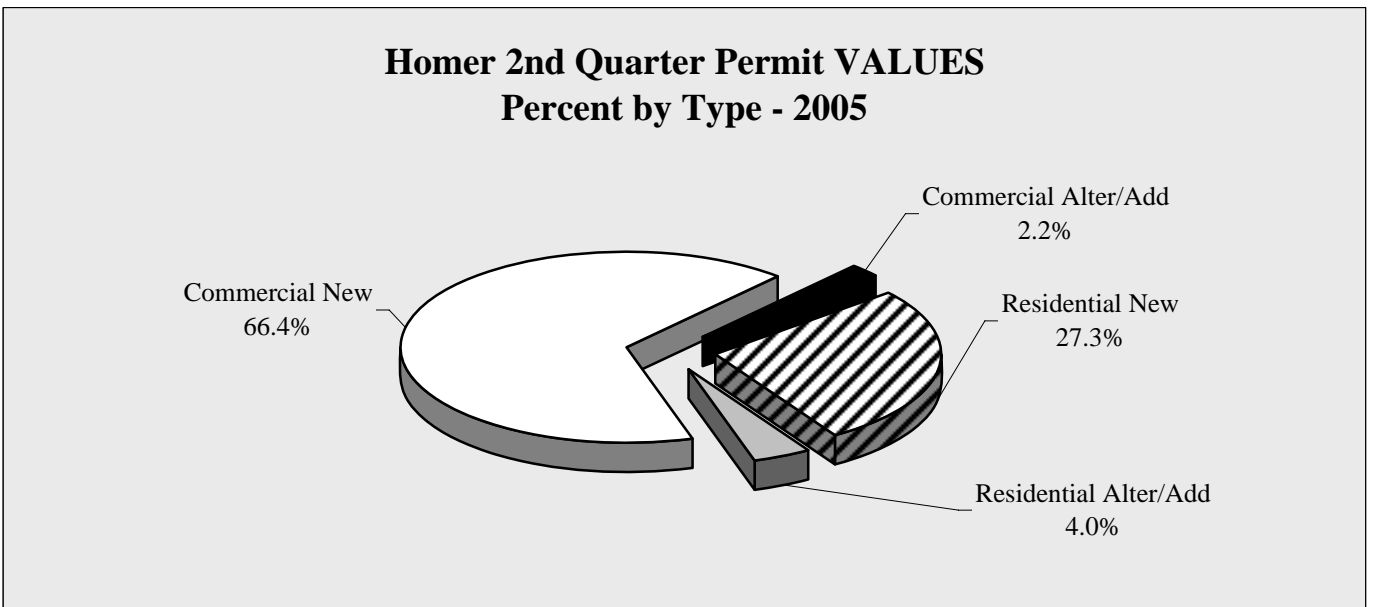

Chart 2.14

# Homer Construction

<b>Homer 2nd Quarter Permit VOLUME by Type - 1999-2005</b>								
	1999	2000	2001	2002	2003	2004	2005	Annual Change
Residential New	9	7	14	9	17	15	22	46.7%
Residential Alter/Add	4	2	12	5	6	5	13	160.0%
Commercial New	7	3	3	1	7	5	9	80.0%
Commercial Alter/Add	1	8	5	2	4	1	2	100.0%
<b>Total</b>	<b>21</b>	<b>20</b>	<b>34</b>	<b>17</b>	<b>34</b>	<b>26</b>	<b>46</b>	<b>76.9%</b>
Annual Change		-4.8%	70.0%	-50.0%	100.0%	-23.5%	76.9%	

Table 2.10

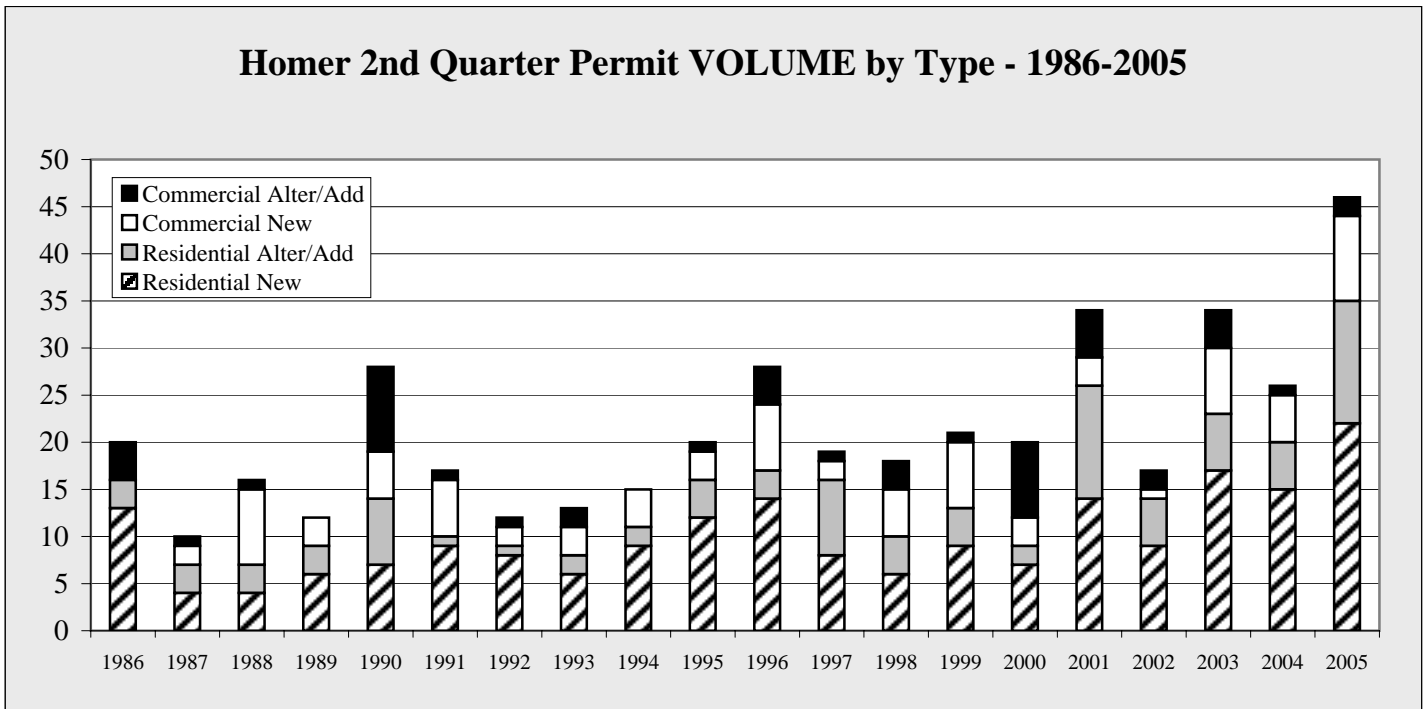

Chart 2.15

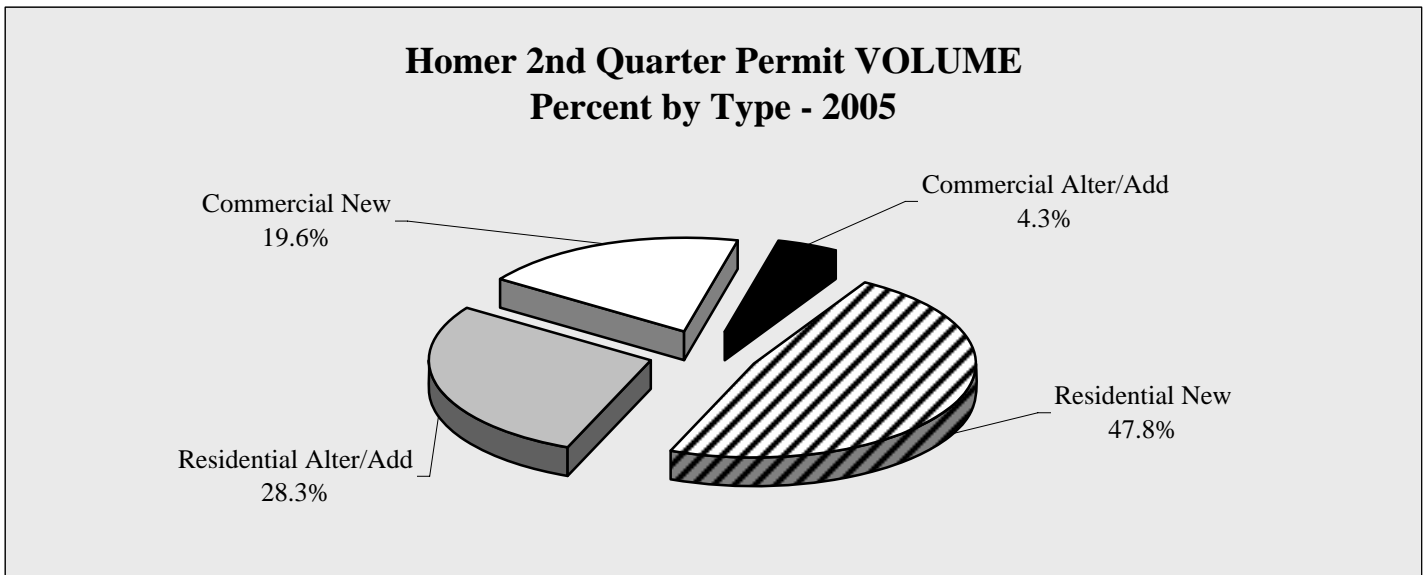

Chart 2.16

# Homer Construction

Homer YTD 6/30 Permit VALUES by Type - 1999-2005 - in \$								
	1999	2000	2001	2002	2003	2004	2005	Annual Change
Residential New	2,711,000	1,260,040	2,393,800	2,200,220	4,791,280	5,092,900	4,766,400	-6.4%
Residential Alter/Add	118,000	120,500	366,440	214,360	471,600	407,250	452,500	11.1%
Commercial New	1,790,000	810,480	1,770,800	1,000,000	3,535,720	5,615,518	7,577,000	34.9%
Commercial Alter/Add	15,000	1,873,000	261,000	42,349	465,240	32,063	1,552,000	4740.5%
Total	4,634,000	4,064,020	4,792,040	3,456,929	9,263,840	11,147,731	14,347,900	28.7%
Annual Change		-12.3%	17.9%	-27.9%	168.0%	20.3%	28.7%	

Table 2.11

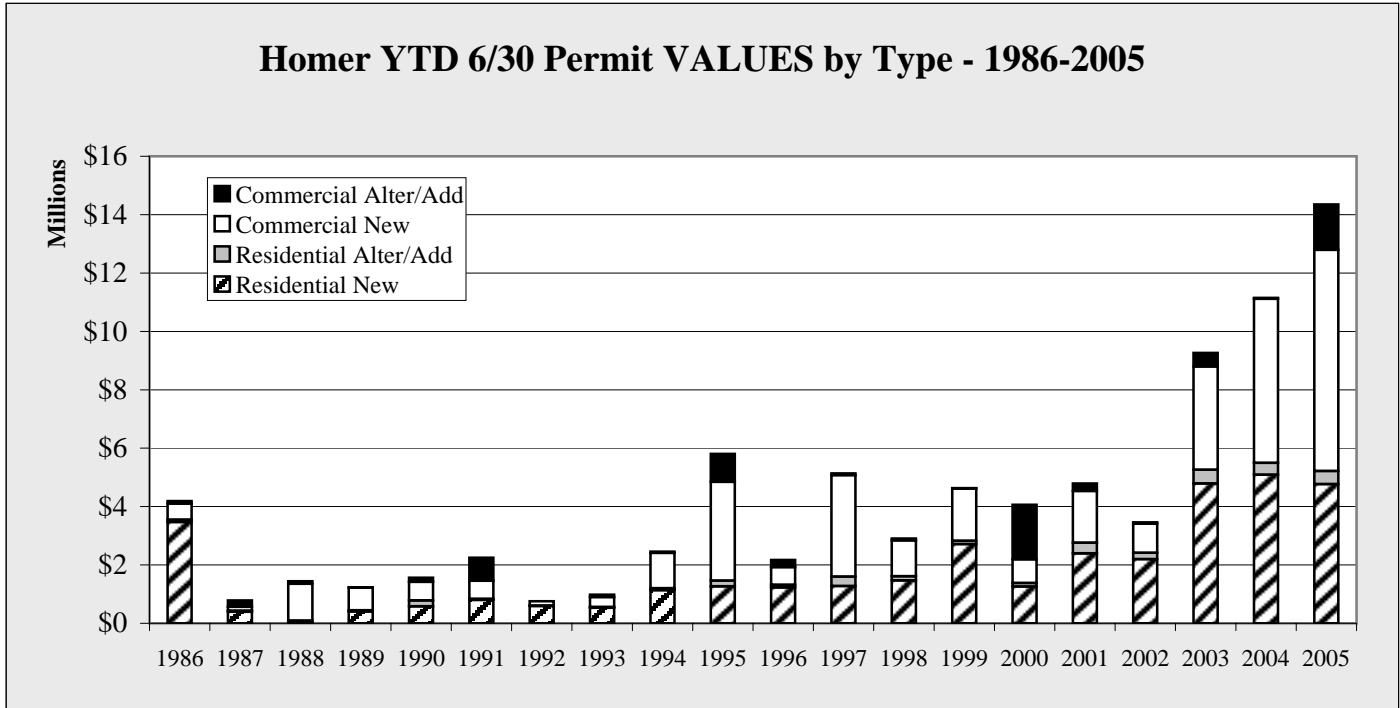

Chart 2.17

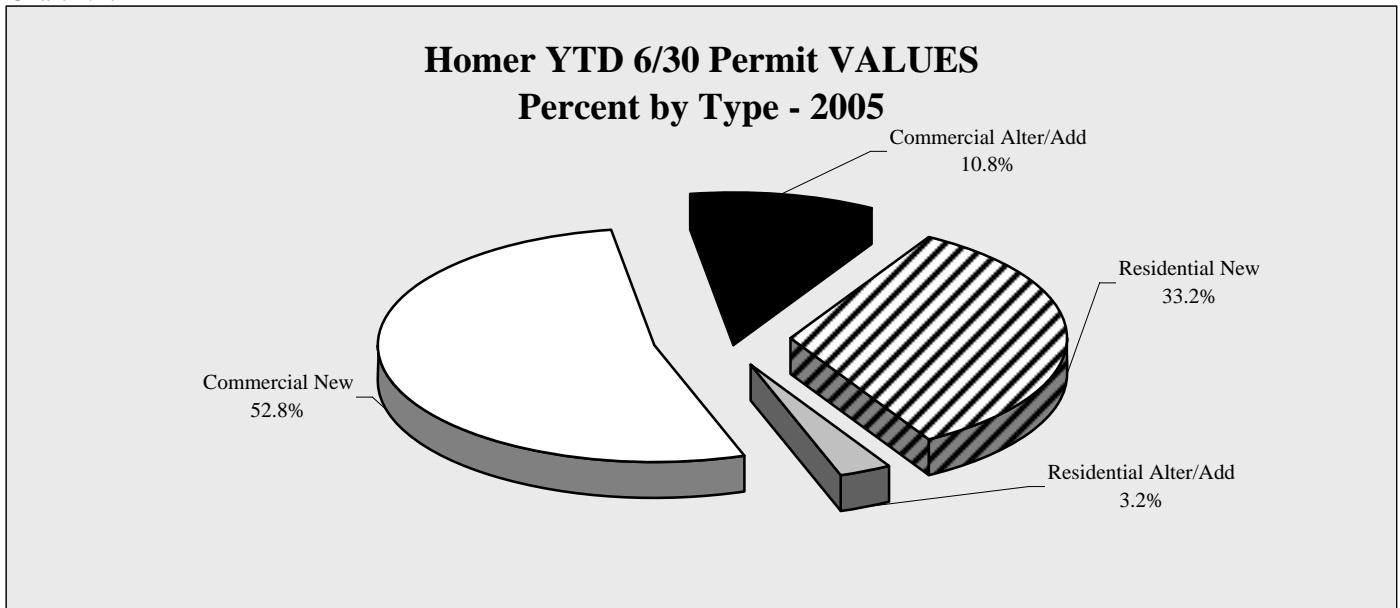

Chart 2.18

# Homer Construction

Homer YTD 6/30 Permit VOLUME by Type - 1999-2005								
	1999	2000	2001	2002	2003	2004	2005	Annual Change
Residential New	12	11	17	17	23	26	32	23.1%
Residential Alter/Add	4	3	13	6	14	7	14	100.0%
Commercial New	9	4	5	1	7	7	11	57.1%
Commercial Alter/Add	1	11	6	3	8	2	7	250.0%
<b>Total</b>	<b>26</b>	<b>29</b>	<b>41</b>	<b>27</b>	<b>52</b>	<b>42</b>	<b>64</b>	<b>52.4%</b>
Annual Change		11.5%	41.4%	-34.1%	92.6%	-19.2%	52.4%	

Table 2.12

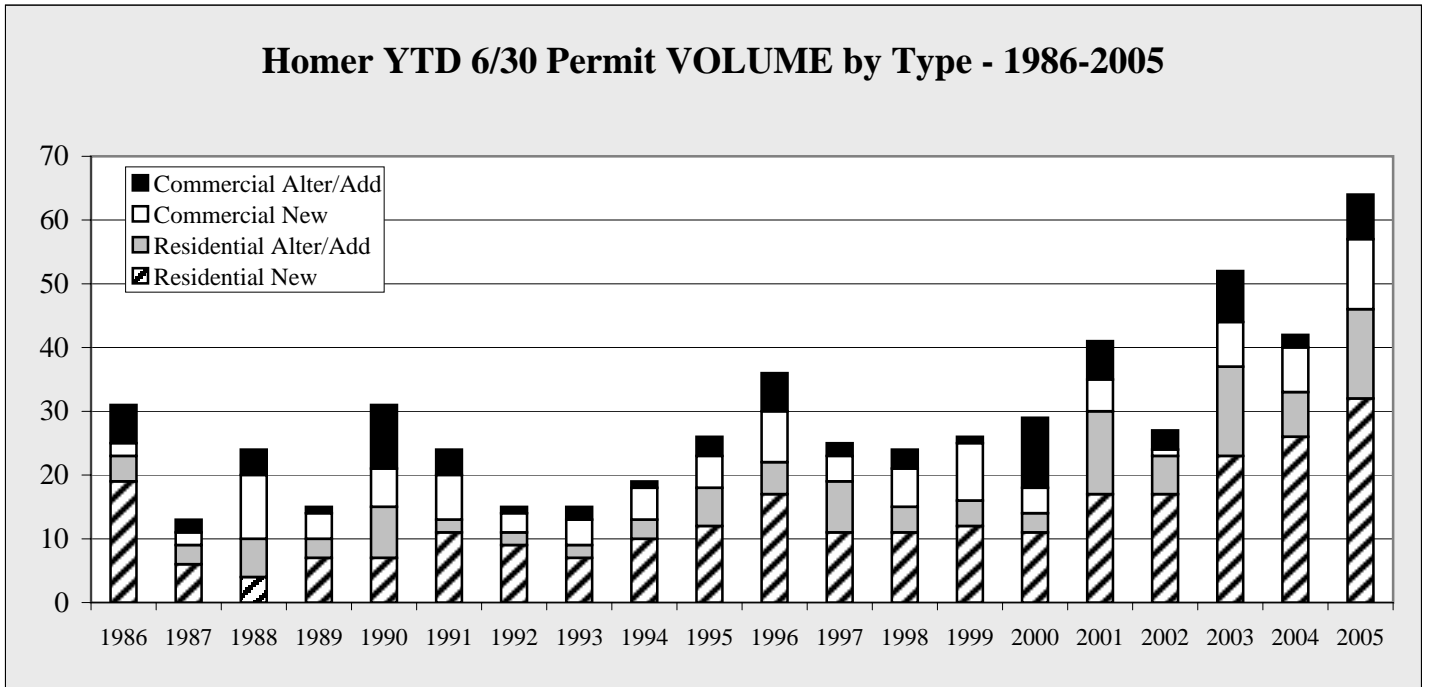

Chart 2.19

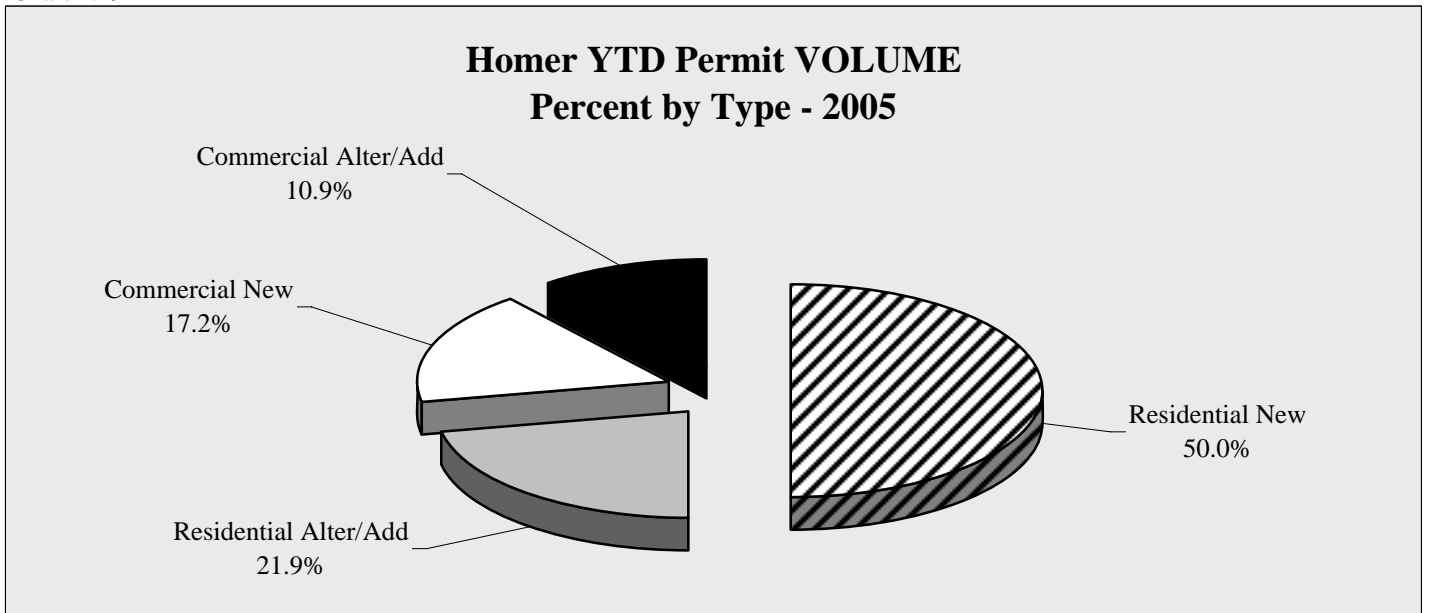

Chart 2.20

# Homer Construction

<b>Homer Annual Permit VALUES by Type by Quarter - 1998-2005 - in \$</b>					
	1st Quarter	2nd Quarter	3rd Quarter	4th Quarter	Total
<b>1998</b>					
Residential - New	594,000	875,000	620,000	761,750	2,850,750
Residential - Add/Alter	0	140,400	254,200	145,000	539,600
Commercial - New	35,970	1,192,036	41,019	1,259,000	2,528,025
Commercial - Add/Alter	0	66,500	175,000	40,000	281,500
<b>TOTAL</b>	<b>629,970</b>	<b>2,273,936</b>	<b>1,090,219</b>	<b>2,205,750</b>	<b>6,199,875</b>
<b>1999</b>					
Residential - New	1,673,000	1,038,000	740,000	195,000	3,646,000
Residential - Add/Alter	0	118,000	199,000	50,000	367,000
Commercial - New	270,000	1,520,000	4,800,000	316,000	6,906,000
Commercial - Add/Alter	0	15,000	6,000	0	21,000
<b>TOTAL</b>	<b>1,943,000</b>	<b>2,691,000</b>	<b>5,745,000</b>	<b>561,000</b>	<b>10,940,000</b>
<b>2000</b>					
Residential - New	392,600	867,440	1,025,000	326,000	2,611,040
Residential - Add/Alter	5,500	115,000	109,560	0	230,060
Commercial - New	85,000	725,480	805,000	48,000	1,663,480
Commercial - Add/Alter	1,315,000	558,000	207,410	543,982	2,624,392
<b>TOTAL</b>	<b>1,798,100</b>	<b>2,265,920</b>	<b>2,146,970</b>	<b>917,982</b>	<b>7,128,972</b>
<b>2001</b>					
Residential - New	300,000	2,093,800	1,161,680	492,300	4,047,780
Residential - Add/Alter	60,000	306,440	122,720	120,000	609,160
Commercial - New	285,000	1,485,800	340,000	300,000	2,410,800
Commercial - Add/Alter	45,000	216,000	1,371,950	11,100,000	12,732,950
<b>TOTAL</b>	<b>690,000</b>	<b>4,102,040</b>	<b>2,996,350</b>	<b>12,012,300</b>	<b>19,800,690</b>
<b>2002</b>					
Residential - New	891,760	1,308,460	1,466,300	560,200	4,226,720
Residential - Add/Alter	8,960	205,400	217,940	104,320	536,620
Commercial - New	0	1,000,000	3,912,740	78,000	4,990,740
Commercial - Add/Alter	28,000	14,349	180,350	72,000	294,699
<b>TOTAL</b>	<b>928,720</b>	<b>2,528,209</b>	<b>5,777,330</b>	<b>814,520</b>	<b>10,048,779</b>
<b>2003</b>					
Residential - New	979,800	3,811,480	2,106,275	1,222,900	8,120,455
Residential - Add/Alter	232,540	239,060	285,000	50,000	806,600
Commercial - New	0	3,535,720	628,800	1,600,000	5,764,520
Commercial - Add/Alter	122,000	343,240	0	170,000	635,240
<b>TOTAL</b>	<b>1,334,340</b>	<b>7,929,500</b>	<b>3,020,075</b>	<b>3,042,900</b>	<b>15,326,815</b>
<b>2004</b>					
Residential - New	2,597,500	2,495,400	1,225,600	377,000	6,695,500
Residential - Add/Alter	201,520	205,730	851,300	437,000	1,695,550
Commercial - New	915,000	4,700,518	6,225,000	2,560,000	14,400,518
Commercial - Add/Alter	0	32,063	1,230,000	17,000	1,279,063
<b>TOTAL</b>	<b>3,714,020</b>	<b>7,433,711</b>	<b>9,531,900</b>	<b>3,391,000</b>	<b>24,070,631</b>
<b>2005</b>					
Residential - New	1,694,400	3,072,000			4,766,400
Residential - Add/Alter	1,500	451,000			452,500
Commercial - New	108,000	7,469,000			7,577,000
Commercial - Add/Alter	1,302,000	250,000			1,552,000
<b>TOTAL</b>	<b>3,105,900</b>	<b>11,242,000</b>			<b>14,347,900</b>

Table 2.13

# Homer Construction

<b>Homer Annual Permit VOLUME by Type by Quarter - 1998-2005</b>					
	1st Quarter	2nd Quarter	3rd Quarter	4th Quarter	Total
<b>1998</b>					
Residential - New	5	6	6	6	23
Residential - Add/Alter	0	4	5	2	11
Commercial - New	1	5	2	1	9
Commercial - Add/Alter	0	3	1	1	5
<b>TOTAL</b>	<b>6</b>	<b>18</b>	<b>14</b>	<b>10</b>	<b>48</b>
<b>1999</b>					
Residential - New	3	9	6	3	21
Residential - Add/Alter	0	4	11	2	17
Commercial - New	2	7	2	1	12
Commercial - Add/Alter	0	1	1	0	2
<b>TOTAL</b>	<b>5</b>	<b>21</b>	<b>20</b>	<b>6</b>	<b>52</b>
<b>2000</b>					
Residential - New	4	7	8	4	23
Residential - Add/Alter	1	2	5	0	8
Commercial - New	1	3	2	2	8
Commercial - Add/Alter	3	8	6	2	19
<b>TOTAL</b>	<b>9</b>	<b>20</b>	<b>21</b>	<b>8</b>	<b>58</b>
<b>2001</b>					
Residential - New	3	14	9	4	30
Residential - Add/Alter	1	12	4	2	19
Commercial - New	2	3	2	1	8
Commercial - Add/Alter	1	5	7	2	15
<b>TOTAL</b>	<b>7</b>	<b>34</b>	<b>22</b>	<b>9</b>	<b>72</b>
<b>2002</b>					
Residential - New	8	9	10	5	32
Residential - Add/Alter	1	5	8	6	20
Commercial - New	0	1	6	1	8
Commercial - Add/Alter	1	2	3	1	7
<b>TOTAL</b>	<b>10</b>	<b>17</b>	<b>27</b>	<b>13</b>	<b>67</b>
<b>2003</b>					
Residential - New	6	17	15	9	47
Residential - Add/Alter	8	6	3	2	19
Commercial - New	0	7	3	1	11
Commercial - Add/Alter	4	4	0	1	9
<b>TOTAL</b>	<b>18</b>	<b>34</b>	<b>21</b>	<b>13</b>	<b>86</b>
<b>2004</b>					
Residential - New	11	15	9	6	41
Residential - Add/Alter	2	5	21	9	37
Commercial - New	2	5	8	7	22
Commercial - Add/Alter	1	1	4	2	8
<b>TOTAL</b>	<b>16</b>	<b>26</b>	<b>42</b>	<b>24</b>	<b>108</b>
<b>2005</b>					<b>Year to Date</b>
Residential - New	10	22			32
Residential - Add/Alter	1	13			14
Commercial - New	2	9			11
Commercial - Add/Alter	5	2			7
<b>TOTAL</b>	<b>18</b>	<b>46</b>			<b>64</b>

Table 2.14

# Homer Cost of Food

Cost of food data is collected by the University of Alaska, Fairbanks Cooperative Extension. Each quarter the Cooperative Extension surveys up to three grocers in communities throughout the state to determine the cost of food for one week. Specific guidelines are presented to the surveyors regarding item size and sale price for 104 items.

<b>HOMER</b>							
	June 2000	June 2001	June 2002	June 2003	June 2004	June 2005	Annual Change
Sales Tax (in percent)	5.5	5.5	5.5	5.5	5.5	5.5	
Percent of Food Unavailable	0.0	0.0	0.0	0.0	0.0	5.5	
<b>Children</b>							
Child 1 year	19.47	21.20	20.80	19.23	22.29	5.5	15.9%
Child 2 years			20.80	19.14	21.86	5.5	14.2%
Children 3-5 years	21.40	21.20	22.87	22.11	24.00	5.5	8.5%
Children 6-8 years	28.50	30.91	30.42	29.66	32.09	5.5	8.2%
Children 9-11 years	32.25	35.02	34.45	34.60	36.15	5.5	4.5%
<b>Males</b>							
Males 12-14 years	36.51	39.64	39.01	37.82	40.95	5.5	8.3%
Males 15-19 years	37.73	40.91	40.25	39.31	42.04	5.5	6.9%
Males 20-50 years	37.42	40.59	40.04	39.23	41.82	5.5	6.6%
Males 51 years & over	35.70	38.60	37.96	36.94	39.81	5.5	7.8%
<b>Females</b>							
Females 12-19 years	31.44	34.17	33.62	31.94	35.28	5.5	10.5%
Females 20-50 years	32.76	35.43	34.86	33.49	36.43	5.5	8.8%
Females 51 years and over	31.84	34.58	33.93	33.19	35.44	5.5	6.8%
<b>Families</b>							
Family of 2 (20-50 years)	77.18	83.62	82.40	80.00	86.07	5.5	7.6%
Family of 2 (51 & older)	74.34	80.51	79.08	77.14	82.76	5.5	7.3%
Family of 4 children 1-5 years	111.05	120.42	118.57	113.99	124.10	5.5	8.9%
Family of 4 children 6-11 years	130.93	141.96	139.77	136.98	146.48	5.5	6.9%
<b>Utilities</b>							
Electricity, 1000 kWh	103.47	112.43	118.93	123.72	101.30	5.5	-18.1%
Heating oil, 55 gal	86.35	78.65	61.60	82.50	105.05	5.5	27.3%
Gas-55 gal unleaded auto	95.65	98.40	94.55	101.15	0.00	5.5	-100.0%
Lumber, 2X4X8'	2.94	3.43	3.02	2.73	3.83	5.5	40.3%
Propane, 100 LB refill	33.22	38.59	38.71	38.23	47.32	5.5	23.8%

Table 2.16



# Homer Cost of Food

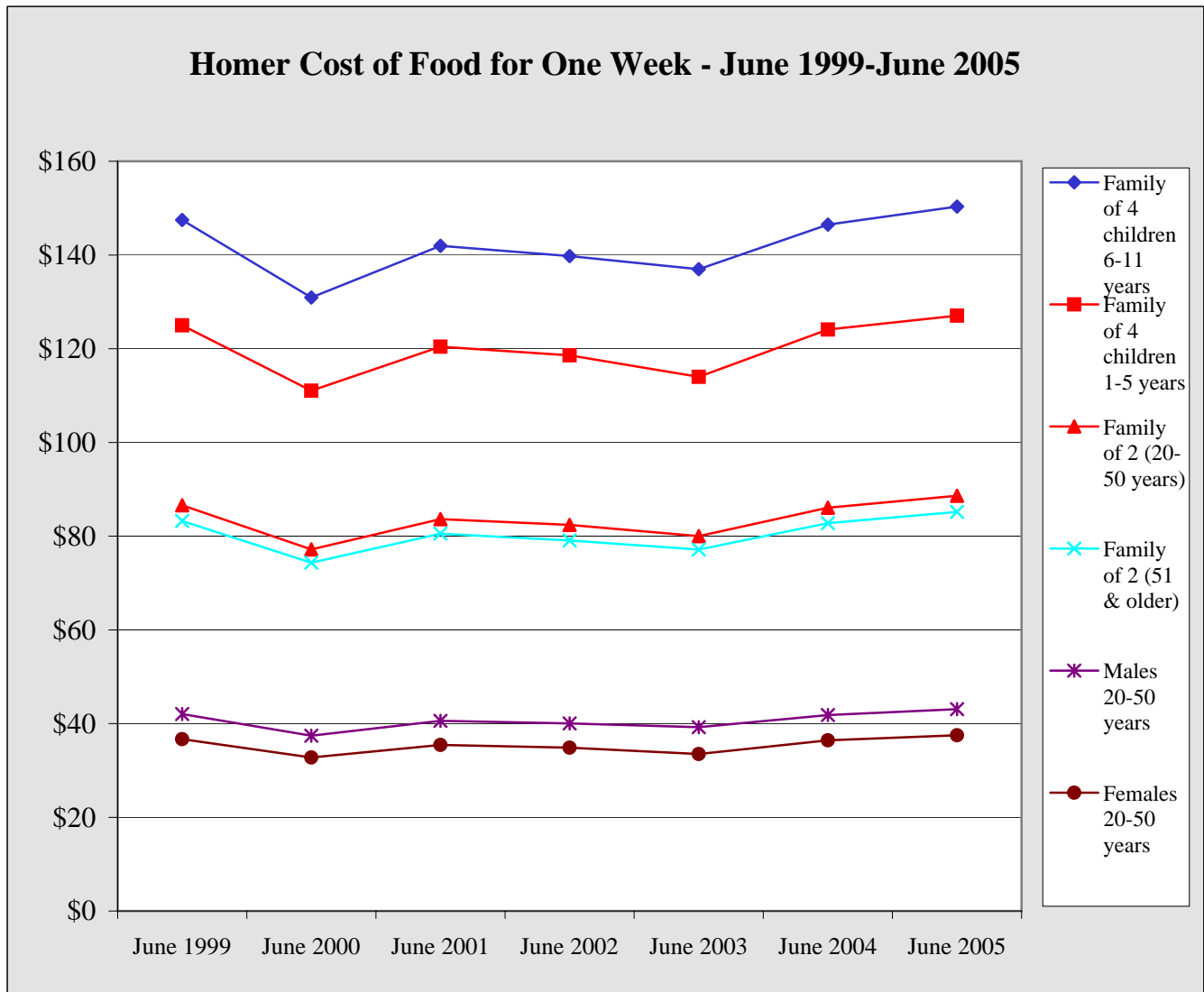

Chart 2.21

# Homer Population

## Homer Select Census Detail - 1990 v 2000

<b>Population</b>					<b>Housing</b>				
	1990	2000	Percent Change	Percent of Total		1990	2000	Percent Change	Percent of Total
Total Population	3,660	3,946	7.8%	100.0%	<b>Total Households</b>	1,411	1,599	13.3%	100.0%
Male	1,869	1,951	4.4%	49.4%	Family Households	912	1,009	10.6%	63.1%
Female	1,791	1,995	11.4%	50.6%	With Children Under 18	NA	553	NA	34.6%
Under 5 years	333	254	-23.7%	6.4%	Married Couple Family	706	772	9.3%	48.3%
5 to 9 years	346	297	-14.2%	7.5%	With Own Children Under 18	NA	381	NA	23.8%
10 to 14 years	277	327	18.1%	8.3%	Female Householder, no husband present	NA	162	NA	10.1%
15 to 19 years	234	319	36.3%	8.1%	With Own Children Under 18	NA	123	NA	7.7%
20 to 24 years	172	177	2.9%	4.5%	Average Household Size	2.54	2.40	NA	0.2%
25 to 34 years	672	401	-40.3%	10.2%	Average Family Size	NA	2.99	NA	0.2%
35 to 44 years	774	659	-14.9%	16.7%	<b>Total Housing Units</b>	1,673	1,873	NA	117.1%
45 to 54 years	389	748	92.3%	19.0%	Occupied Housing Units	1,411	1,599	13.3%	100.0%
55 to 59 years	108	223	106.5%	5.7%	Vacant Housing Units	262	274	4.6%	17.1%
60 to 64 years	95	143	50.5%	3.6%	Seasonal, Recreational, Occasional Use	65	129	98.5%	8.1%
65 to 74 years	172	207	20.3%	5.2%	Owner Vacancy Rate	NA	2.9%	NA	NA
75 to 84 years	72	143	98.6%	3.6%	Rental Vacancy Rate	NA	10.9%	NA	NA
85 years and over	16	48	200.0%	1.2%	Owner Occupied Units	763	987	29.4%	61.7%
Median Age	32.4	38.8	19.8%	NA	Renter Occupied Units	648	612	-5.6%	38.3%
18 Years and Over	1,111	2,857	157.2%	72.4%	<b>Marital Status (over 15)</b>	NA	3,071	NA	NA
Male	NA	1,419	NA	NA	Never married	NA	719	NA	23.4%
Female	NA	1,438	NA	NA	Married except separated	NA	1,722	NA	56.1%
65 Years and Over	260	398	53.1%	10.1%	Separated	NA	60	NA	2.0%
Male	NA	182	NA	NA	Widowed	NA	111	NA	3.6%
Female	NA	216	NA	NA	Divorced	NA	459	NA	14.9%
<b>Place of Birth</b>					<b>Disabled, Noninstitutionalized</b>				
Native Born	3,559	3,813	7.1%	96.6%	Population 5 to 20	NA	988	NA	100.0%
Born in Alaska	NA	1,190	NA	30.2%	With a Disability	NA	37	NA	3.7%
Born in other state	NA	2,581	NA	65.4%	Population 21 to 64	NA	2,242	NA	100.0%
Foreign Born	101	141	39.6%	3.6%	With a Disability	NA	362	NA	16.1%
Naturalized Citizen	NA	99	NA	2.5%	Percent Employed	NA	50.0%	NA	0.0%
Not a Citizen	NA	42	NA	1.1%	Without a Disability	NA	1,880	NA	83.9%
<b>Veteran Status</b>					Percent Employed	NA	75.7%	NA	0.0%
Civilian veterans	472	454	NA	16.4%	<b>Income in 1999 - Families</b>				
<b>Educational Attainment</b>					Total 1008				
Population 25 years and over					Less than \$10,000	53	46	-13.2%	4.6%
Less than 9th grade	61	35	-42.6%	1.4%	\$10,000 - \$14,999	70	38	-45.7%	3.8%
9th-12th, no diploma	204	16	-92.2%	0.6%	\$15,000 - \$24,999	122	100	-18.0%	9.9%
High School Diploma	671	660	-1.6%	25.7%	\$25,000 - \$34,999	127	93	-26.8%	9.2%
College, no degree	601	829	37.9%	32.3%	\$35,000 - \$49,999	151	182	20.5%	18.1%
Associate Degree	163	132	-19.0%	5.1%	\$50,000 - \$74,999	215	261	21.4%	25.9%
Bachelor's Degree	467	474	1.5%	18.5%	\$75,000 - \$99,999	89	145	62.9%	14.4%
Graduate, Profess Degree	131	274	109.2%	10.7%	\$100,000 - \$149,999	64	107	67.2%	10.6%
Percent HS Grad	88.5%	92.4%	4.4%	0.0%	\$150,000 - \$199,999	30	17	-43.3%	1.7%
Percent Bachelor's +	26.0%	29.2%	12.3%	0.0%	\$200,000 or more	NA	19	NA	1.9%
					Median Income - \$	42,824	53,571	25.1%	NA

Table 2.15

# Kenai Sales

<b>Kenai 2nd Quarter GROSS Sales by Industry - 1999-2005 - in \$</b>								
	1999	2000	2001	2002	2003	2004	2005	Annual Change
Ag, Forest, Fish	1,270,536	3,141,165	787,584	810,865	838,734	1,296,885	2,360,990	82.1%
Mining	64,414	1,309,839	321,650	516,408	872,788	2,172,358	1,068,085	-50.8%
Construction	3,454,181	2,522,636	5,291,031	4,295,333	6,454,835	2,769,875	4,994,592	80.3%
Manufacturing	1,946,098	2,490,501	3,567,493	3,007,187	4,210,293	3,062,848	2,278,566	-25.6%
Trans, Comm, Pub Util	6,040,727	5,888,108	5,834,997	6,155,532	6,152,058	5,560,861	28,105,766	405.4%
Wholesale	2,623,775	4,370,523	5,243,400	4,677,095	4,841,740	5,842,357	6,386,212	9.3%
Retail	35,052,059	35,185,697	42,832,698	34,741,208	28,949,996	39,251,887	40,505,600	3.2%
Finance, Ins, RE	2,725,582	2,912,589	3,513,695	3,667,615	3,256,374	3,219,231	3,116,255	-3.2%
Services	8,427,674	8,337,449	9,281,388	10,058,048	11,847,481	11,099,322	10,387,542	-6.4%
<b>Total</b>	<b>61,605,046</b>	<b>66,158,507</b>	<b>76,673,936</b>	<b>67,929,291</b>	<b>67,424,299</b>	<b>74,275,624</b>	<b>99,203,608</b>	<b>33.6%</b>
Annual Change		7.4%	15.9%	-11.4%	-0.7%	10.2%	33.6%	

Table 3.1

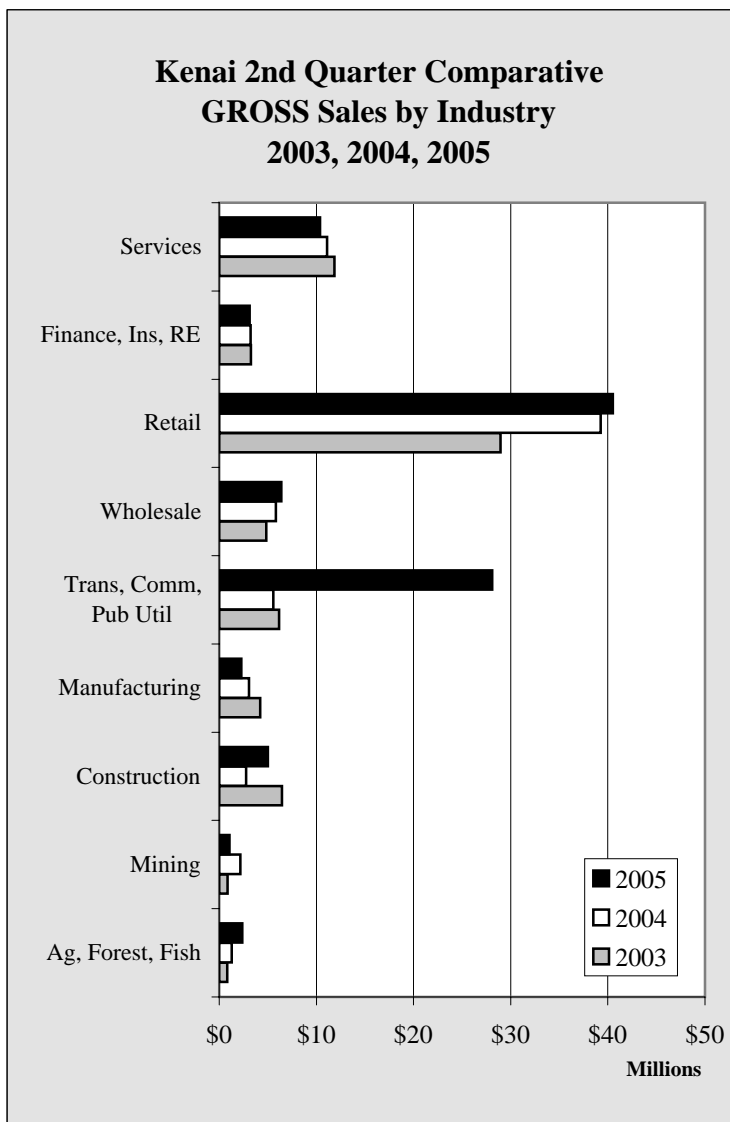

Chart 3.1

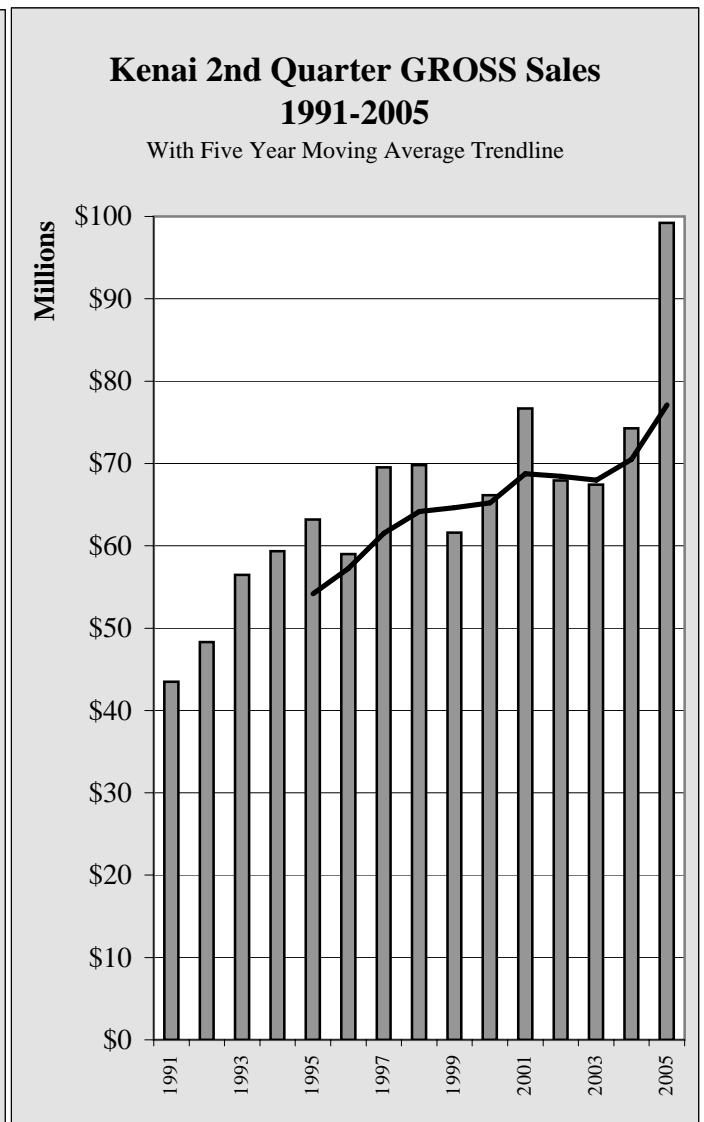

Chart 3.2

# Kenai Sales

<b>Kenai 2nd Quarter TAXABLE Sales by Industry - 1999-2005 - in \$</b>								
	1999	2000	2001	2002	2003	2004	2005	Annual Change
Ag, Forest, Fish	105,339	127,041	113,069	128,556	134,783	159,363	186,963	17.3%
Mining	6,684	32,572	72,568	57,479	46,723	57,575	46,396	-19.4%
Construction	277,050	258,569	268,682	273,401	295,969	294,583	309,866	5.2%
Manufacturing	576,032	678,124	685,042	622,875	687,335	803,910	699,476	-13.0%
Trans, Comm, Pub Util	3,220,508	3,448,167	3,163,762	3,794,883	4,056,076	3,467,903	3,195,056	-7.9%
Wholesale	206,332	246,267	206,838	146,986	111,864	127,610	126,121	-1.2%
Retail	20,456,980	20,739,230	23,717,206	22,876,325	18,246,087	25,145,460	26,623,174	5.9%
Finance, Ins, RE	1,264,393	1,319,015	1,670,033	1,684,226	1,494,804	1,345,408	1,210,927	-10.0%
Services	4,791,749	4,698,864	5,091,469	5,064,834	4,727,913	4,850,846	4,882,756	0.7%
Total	30,905,067	31,547,849	34,988,669	34,649,565	29,801,554	36,252,658	37,280,735	2.8%
Annual Change		2.1%	10.9%	-1.0%	-14.0%	21.6%	2.8%	

Table 3.2

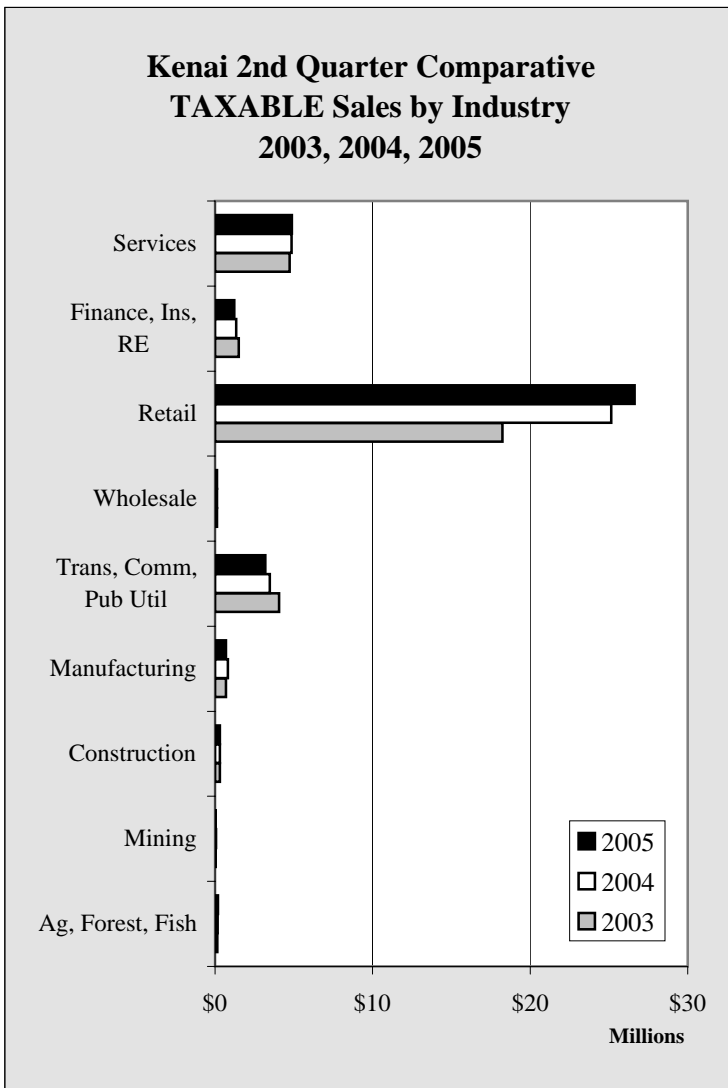

Chart 3.3

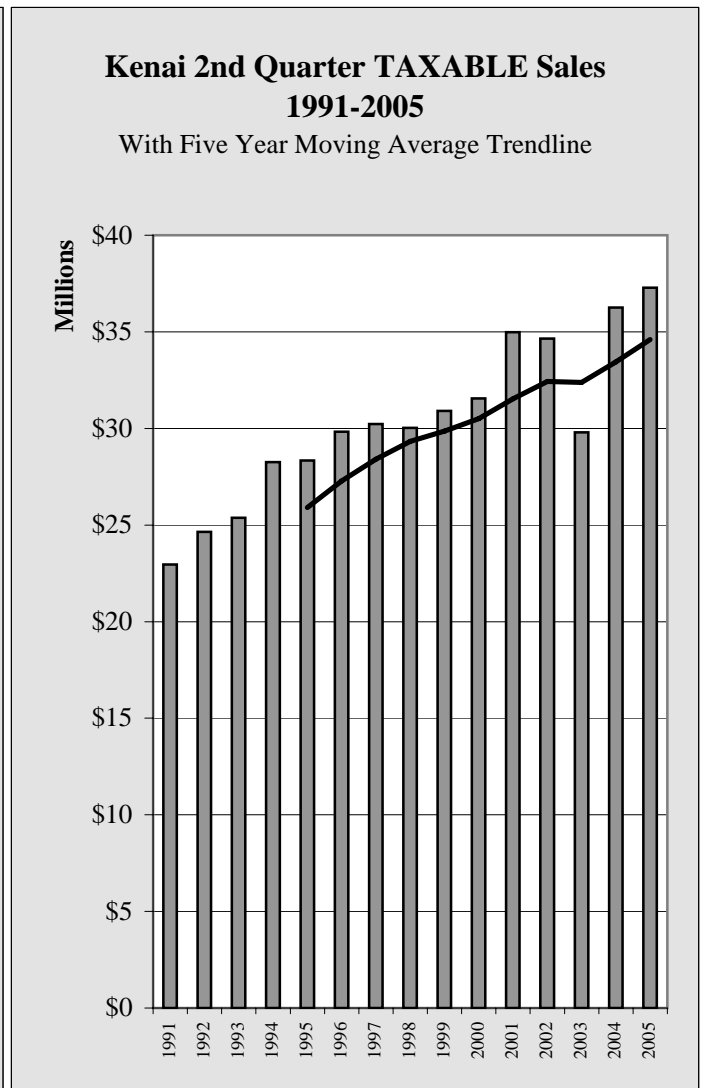

Chart 3.4

# Kenai Sales

Kenai YTD 6/30 GROSS Sales by Industry - 1999-2005 - in \$								
	1999	2000	2001	2002	2003	2004	2005	Annual Change
Ag, Forest, Fish	1,899,646	4,431,098	1,420,941	1,981,179	1,841,384	2,358,671	3,974,543	68.5%
Mining	101,890	2,847,277	1,174,244	2,731,125	1,815,358	4,184,091	3,311,706	-20.9%
Construction	6,510,071	6,201,177	7,205,235	8,072,404	10,570,131	5,084,097	6,970,106	37.1%
Manufacturing	3,421,280	4,759,225	6,376,411	5,263,340	7,207,299	4,672,870	3,978,188	-14.9%
Trans, Comm, Pub Util	12,405,440	12,200,687	11,913,857	12,571,591	13,866,427	12,049,877	48,424,726	301.9%
Wholesale	4,536,478	7,093,957	10,231,346	8,041,983	8,063,479	11,192,139	11,360,515	1.5%
Retail	62,113,136	63,131,221	76,982,734	63,215,353	59,057,226	69,066,167	71,000,786	2.8%
Finance, Ins, RE	5,375,829	5,431,409	6,476,043	7,106,770	6,306,976	6,083,904	5,743,246	-5.6%
Services	14,551,068	15,671,832	17,311,411	19,541,915	20,836,376	20,656,312	19,945,092	-3.4%
Government	223	256	0	0	0	0	0	NA
Total	110,914,838	121,767,883	139,092,222	128,525,660	129,564,656	135,348,128	174,708,908	29.1%
Annual Change		9.8%	14.2%	-7.6%	0.8%	4.5%	29.1%	

Table 3.3

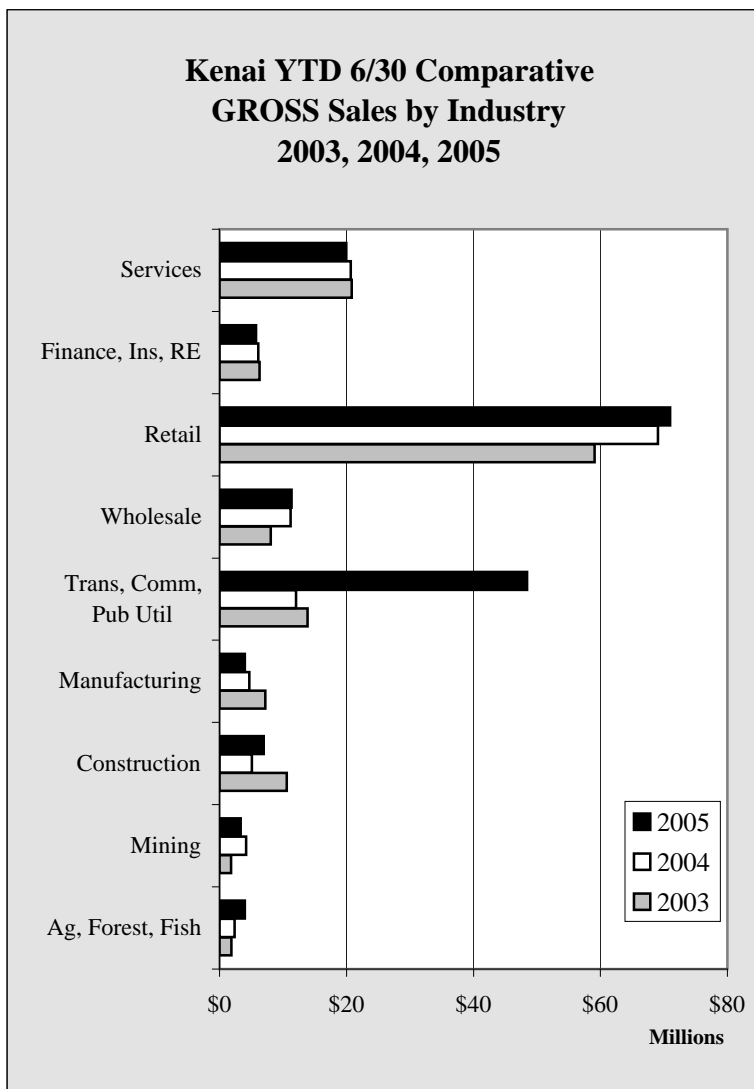

Chart 3.5

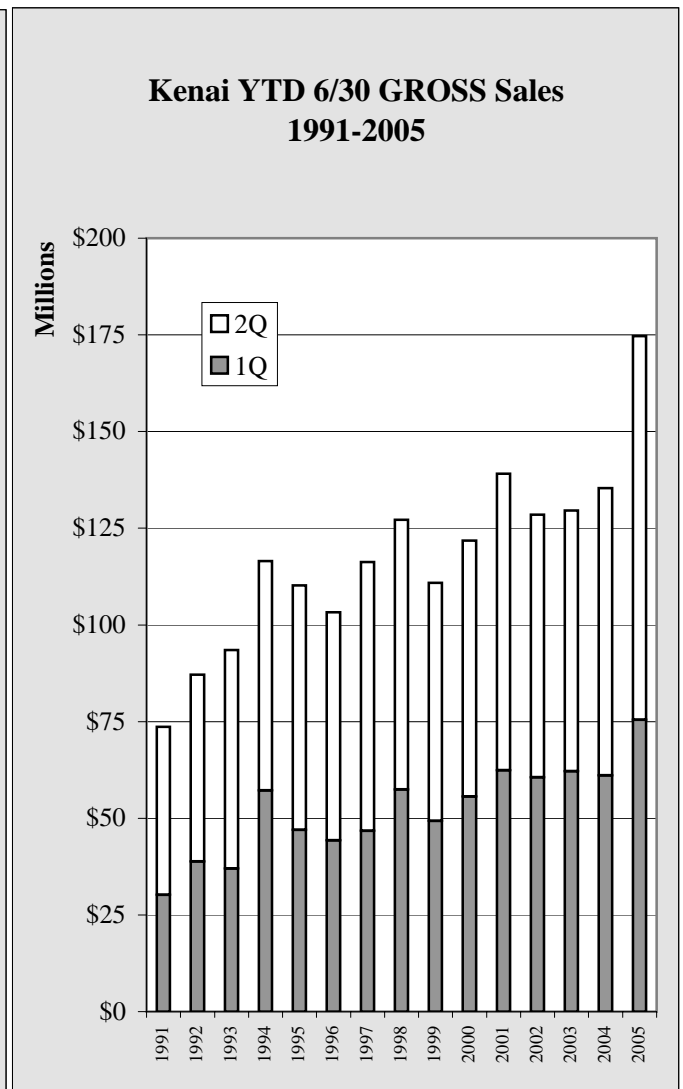

Chart 3.6

# Kenai Sales

<b>Kenai YTD 6/30 TAXABLE Sales by Industry - 1999-2005 - in \$</b>								
	1999	2000	2001	2002	2003	2004	2005	Annual Change
Ag, Forest, Fish	204,569	206,713	201,331	219,165	222,677	256,638	328,585	28.0%
Mining	13,948	63,085	131,380	108,849	80,842	121,402	116,614	-3.9%
Construction	534,081	493,393	505,869	521,974	538,162	564,997	521,128	-7.8%
Manufacturing	932,180	1,114,301	1,122,782	972,235	1,128,627	1,312,672	1,135,560	-13.5%
Trans, Comm, Pub Util	6,807,788	7,109,572	6,562,159	7,574,722	8,988,082	7,407,338	7,100,369	-4.1%
Wholesale	374,813	428,496	386,290	254,776	191,402	279,919	216,139	-22.8%
Retail	36,566,887	36,902,514	41,854,555	41,562,063	38,308,854	44,462,370	46,202,612	3.9%
Finance, Ins, RE	2,468,971	2,549,746	3,197,712	3,329,627	2,975,487	2,601,751	2,363,739	-9.1%
Services	8,185,622	8,201,342	8,915,832	9,044,496	8,460,897	8,791,562	8,789,321	0.0%
Government	223	256	0	0	0	0	0	NA
Total	56,088,859	57,069,162	62,877,910	63,587,907	60,895,030	65,798,649	66,774,067	1.5%
Annual Change		1.7%	10.2%	1.1%	-4.2%	8.1%	1.5%	

Table 3.4

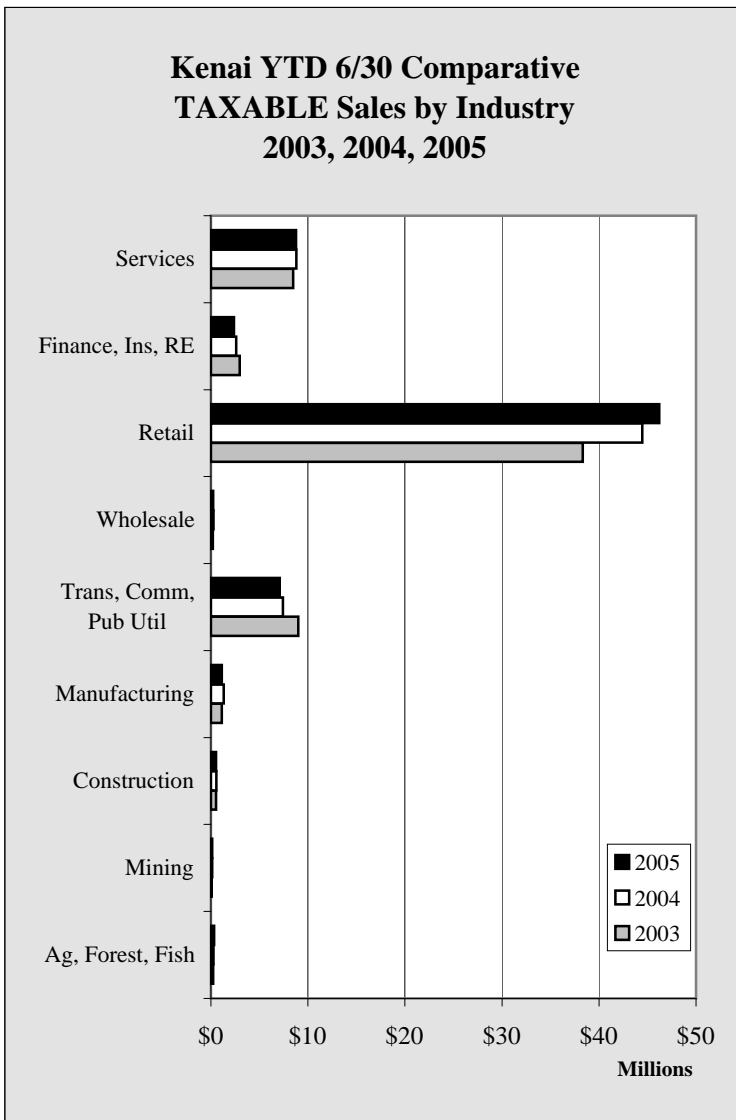

Chart 3.7

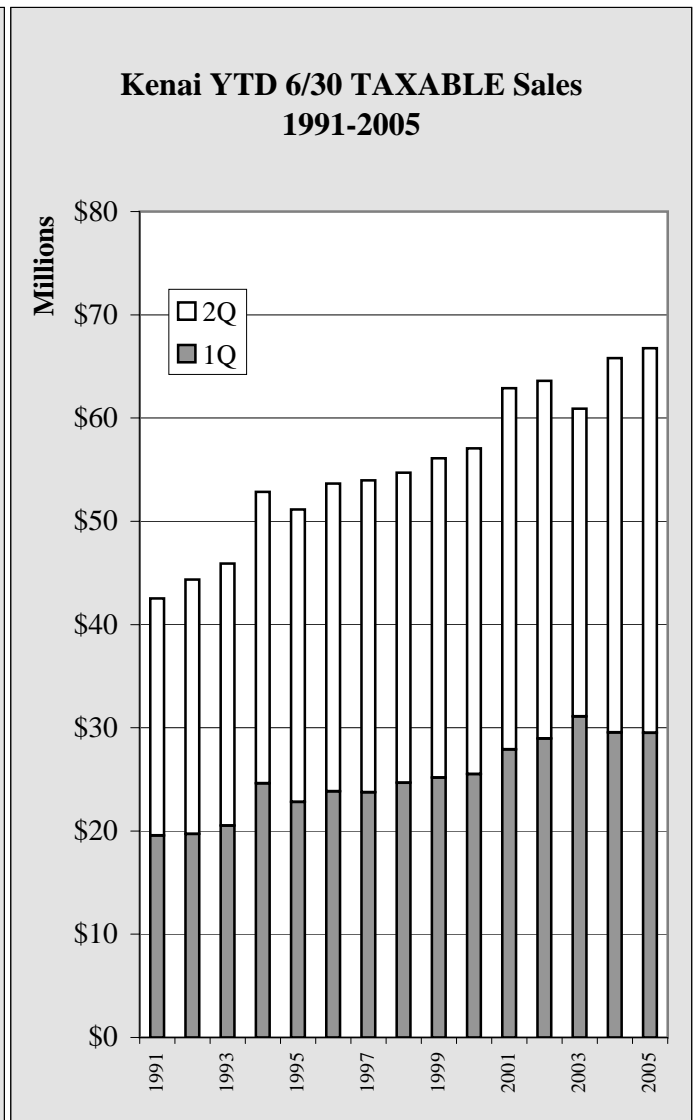

Chart 3.8

# Kenai Sales

**Kenai Annual GROSS Sales by Industry - 1998-2004 - in \$**

	1998	1999	2000	2001	2002	2003	2004	Annual Change
Ag, Forest, Fish	21,856,770	27,031,481	17,757,626	11,304,090	9,488,174	12,584,181	16,349,894	29.9%
Mining	208,531	1,424,691	5,507,130	2,507,234	3,916,074	4,915,930	8,727,840	77.5%
Construction	21,481,466	20,692,714	17,177,398	24,151,985	18,522,782	30,636,346	12,909,992	-57.9%
Manufacturing	7,526,545	7,854,159	10,445,806	12,646,047	12,496,147	14,994,862	9,506,441	-36.6%
Trans, Comm, Pub Util	23,017,785	26,815,943	23,883,929	24,107,421	27,762,814	24,667,417	29,890,326	21.2%
Wholesale	10,194,981	10,520,958	17,902,155	19,965,613	17,521,629	19,037,117	187,702,003	886.0%
Retail	149,397,570	133,272,201	145,306,370	164,046,542	134,565,667	119,219,213	146,046,383	22.5%
Finance, Ins, RE	10,300,066	10,463,600	11,935,000	13,853,920	13,529,801	12,784,912	12,915,093	1.0%
Services	36,094,281	32,669,956	33,766,762	37,842,360	41,942,315	44,500,264	45,266,750	1.7%
Government	1,945	415	288	1,213	0	0	0	NA
Total	280,077,995	270,745,703	283,682,176	310,425,212	279,745,403	283,340,242	469,314,722	65.6%
Annual Change		-3.3%	4.8%	9.4%	-9.9%	1.3%	65.6%	

Table 3.5

**Kenai Annual Comparative  
GROSS Sales by Industry  
2002, 2003, 2004**

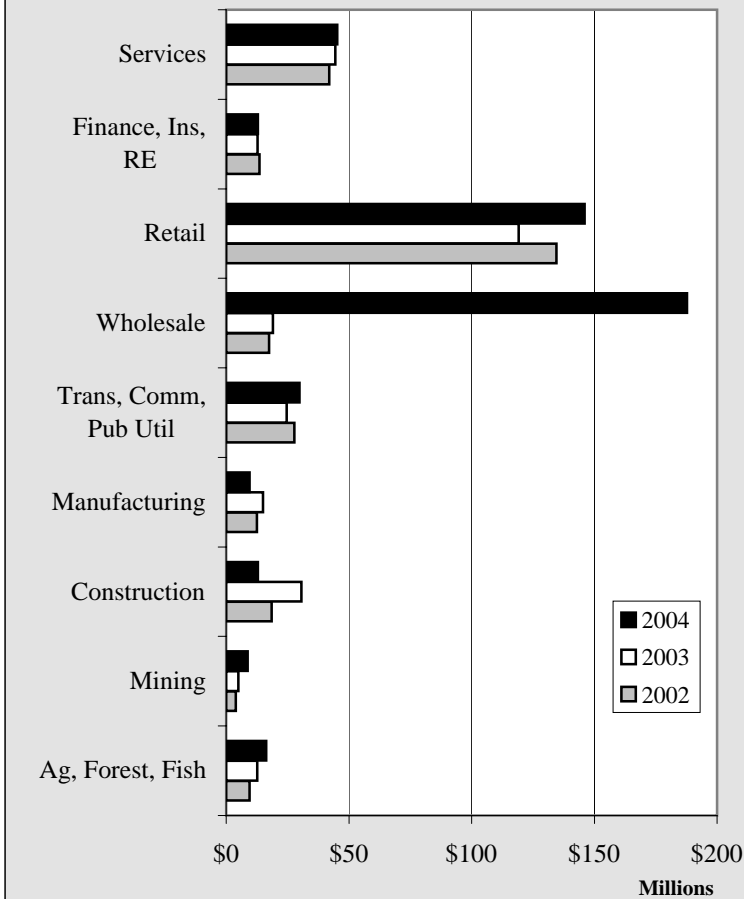

Chart 3.9

**Kenai Annual GROSS Sales  
1991-2004**

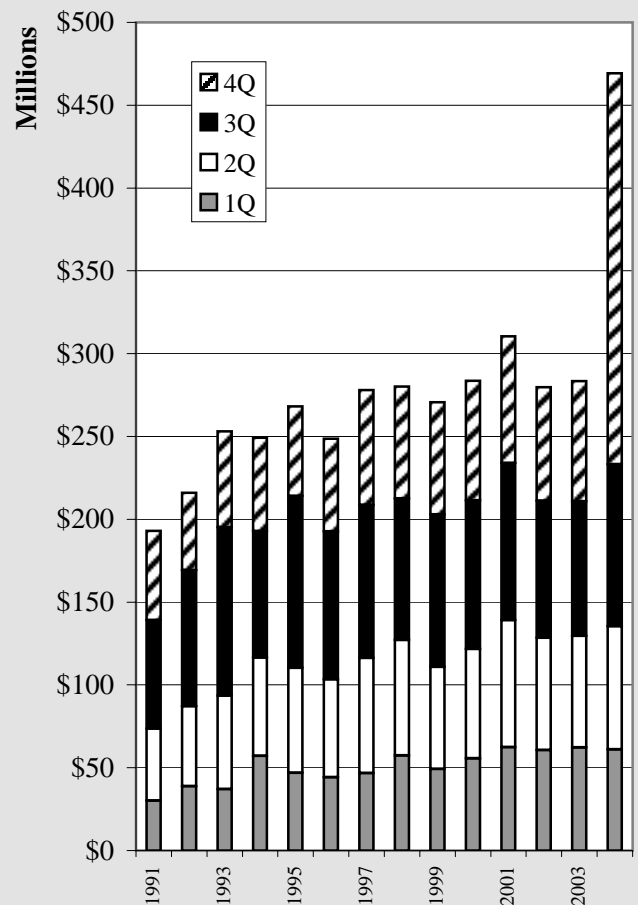

Chart 3.10

# Kenai Sales

<b>Kenai Annual TAXABLE Sales by Industry - 1998-2004 - in \$</b>								
	1998	1999	2000	2001	2002	2003	2004	Annual Change
Ag, Forest, Fish	448,689	513,026	518,603	505,615	505,614	559,313	718,415	28.4%
Mining	49,522	96,651	166,846	223,196	213,971	192,718	262,963	36.4%
Construction	1,200,303	1,180,607	1,085,964	1,171,924	1,111,101	1,172,308	1,152,397	-1.7%
Manufacturing	2,140,912	2,085,657	2,450,721	2,238,645	2,218,515	2,451,929	2,853,082	16.4%
Trans, Comm, Pub Util	12,899,378	15,330,911	13,458,834	13,192,948	16,120,066	15,890,944	14,094,256	-11.3%
Wholesale	877,088	829,682	898,759	727,784	517,025	494,254	473,716	-4.2%
Retail	80,814,442	81,828,974	85,347,467	93,226,651	90,195,938	76,153,080	94,195,956	23.7%
Finance, Ins, RE	4,918,254	4,824,067	5,718,387	6,757,340	6,600,246	5,601,342	5,209,124	-7.0%
Services	16,680,181	17,677,101	18,120,257	18,998,608	19,287,134	18,796,331	19,671,070	4.7%
Government	1,938	415	288	1,213	0	0	0	NA
<b>Total</b>	<b>120,028,769</b>	<b>124,366,676</b>	<b>127,765,838</b>	<b>137,042,711</b>	<b>136,769,610</b>	<b>121,312,219</b>	<b>138,630,979</b>	<b>14.3%</b>
Annual Change		3.6%	2.7%	7.3%	-0.2%	-11.3%	14.3%	

Table 3.6

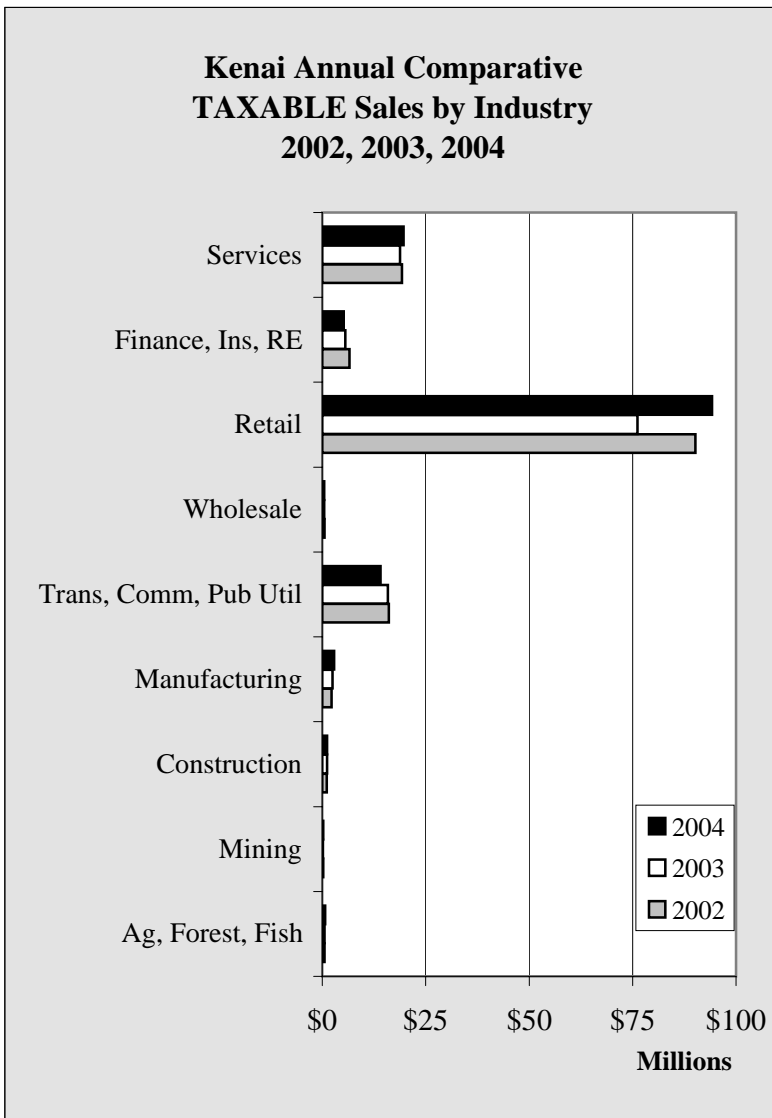

Chart 3.11

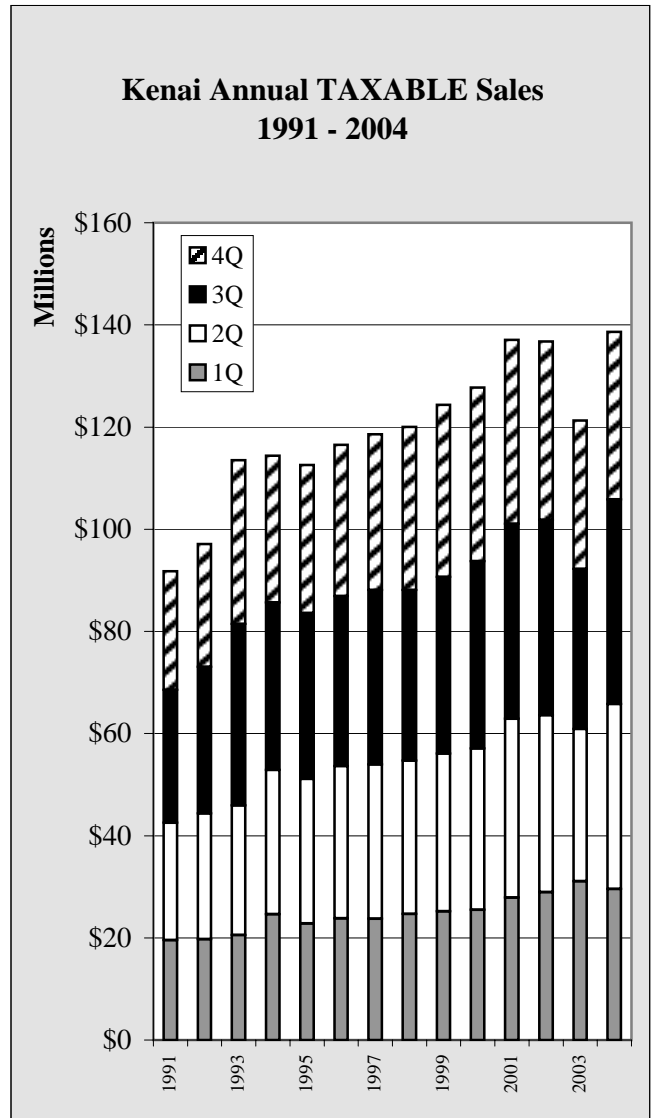

Chart 3.12



# Kenai Sales

<b>Kenai GROSS Sales by Industry by Quarter - 2002-2005 - in \$</b>					
	1st Quarter	2nd Quarter	3rd Quarter	4th Quarter	Total
<b>2002</b>					
Ag, Forestry, Fishing	1,170,314	810,865	7,279,641	227,354	9,488,174
Mining	2,214,717	516,408	805,341	379,608	3,916,074
Construction	3,777,071	4,295,333	4,991,407	5,458,971	18,522,782
Manufacturing	2,256,153	3,007,187	3,464,827	3,767,980	12,496,147
Trans, Comm, Pub Util	6,416,059	6,155,532	8,070,497	7,120,726	27,762,814
Wholesale	3,364,888	4,677,095	5,410,024	4,069,622	17,521,629
Retail	28,474,145	34,741,208	36,679,657	34,670,657	134,565,667
Finance, Ins, RE	3,439,155	3,667,615	3,373,799	3,049,232	13,529,801
Services	9,483,867	10,058,048	12,526,446	9,873,954	41,942,315
Government	0	0	0	0	0
<b>Total</b>	<b>60,596,369</b>	<b>67,929,291</b>	<b>82,601,639</b>	<b>68,618,104</b>	<b>279,745,403</b>
<b>2003</b>					
Ag, Forestry, Fishing	1,002,650	838,734	10,272,676	470,121	12,584,181
Mining	942,570	872,788	1,517,115	1,583,457	4,915,930
Construction	4,115,296	6,454,835	7,865,523	12,200,692	30,636,346
Manufacturing	2,997,006	4,210,293	5,529,544	2,258,019	14,994,862
Trans, Comm, Pub Util	7,714,369	6,152,058	4,859,475	5,941,515	24,667,417
Wholesale	3,221,739	4,841,740	5,639,800	5,333,838	19,037,117
Retail	30,107,230	28,949,996	30,099,399	30,062,588	119,219,213
Finance, Ins, RE	3,050,602	3,256,374	3,127,817	3,350,119	12,784,912
Services	8,988,895	11,847,481	12,318,427	11,345,461	44,500,264
Government	0	0	0	0	0
<b>Total</b>	<b>62,140,357</b>	<b>67,424,299</b>	<b>81,229,776</b>	<b>72,545,810</b>	<b>283,340,242</b>
<b>2004</b>					
Ag, Forestry, Fishing	1,061,786	1,296,885	12,241,519	1,749,704	16,349,894
Mining	2,011,733	2,172,358	2,186,041	2,357,708	8,727,840
Construction	2,314,222	2,769,875	3,622,703	4,203,192	12,909,992
Manufacturing	1,610,022	3,062,848	2,757,875	2,075,696	9,506,441
Trans, Comm, Pub Util	6,489,016	5,560,861	11,816,038	6,024,411	29,890,326
Wholesale	5,349,782	5,842,357	7,155,295	169,354,569	187,702,003
Retail	29,814,280	39,251,887	40,496,449	36,483,767	146,046,383
Finance, Ins, RE	2,864,673	3,219,231	3,430,855	3,400,334	12,915,093
Services	9,556,990	11,099,322	14,140,495	10,469,943	45,266,750
Government	0	0	0	0	0
<b>Total</b>	<b>61,072,504</b>	<b>74,275,624</b>	<b>97,847,270</b>	<b>236,119,324</b>	<b>469,314,722</b>
<b>2005</b>					
					<b>Year to Date</b>
Ag, Forestry, Fishing	1,613,553	2,360,990			3,974,543
Mining	2,243,621	1,068,085			3,311,706
Construction	1,975,514	4,994,592			6,970,106
Manufacturing	1,699,622	2,278,566			3,978,188
Trans, Comm, Pub Util	20,318,960	28,105,766			48,424,726
Wholesale	4,974,303	6,386,212			11,360,515
Retail	30,495,186	40,505,600			71,000,786
Finance, Ins, RE	2,626,991	3,116,255			5,743,246
Services	9,557,550	10,387,542			19,945,092
Government	0	0			0
<b>Total</b>	<b>75,505,300</b>	<b>99,203,608</b>	<b>0</b>	<b>0</b>	<b>174,708,908</b>

Table 3.7

# Kenai Sales

<b>Kenai TAXABLE Sales by Industry by Quarter - 2002-2005 - in \$</b>					
	1st Quarter	2nd Quarter	3rd Quarter	4th Quarter	Total
<b>2002</b>					
Ag, Forestry, Fishing	90,609	128,556	200,238	86,211	505,614
Mining	51,370	57,479	52,898	52,224	213,971
Construction	248,573	273,401	292,612	296,515	1,111,101
Manufacturing	349,360	622,875	754,966	491,314	2,218,515
Trans, Comm, Pub Util	3,779,839	3,794,883	4,235,801	4,309,543	16,120,066
Wholesale	107,790	146,986	138,933	123,316	517,025
Retail	18,685,738	22,876,325	24,650,115	23,983,760	90,195,938
Finance, Ins, RE	1,645,401	1,684,226	1,706,454	1,564,165	6,600,246
Services	3,979,662	5,064,834	6,160,963	4,081,675	19,287,134
Government	0	0	0	0	0
<b>Total</b>	<b>28,938,342</b>	<b>34,649,565</b>	<b>38,192,980</b>	<b>34,988,723</b>	<b>136,769,610</b>
<b>2003</b>					
Ag, Forestry, Fishing	87,894	134,783	237,344	99,292	559,313
Mining	34,119	46,723	51,411	60,465	192,718
Construction	242,193	295,969	316,506	317,640	1,172,308
Manufacturing	441,292	687,335	816,883	506,419	2,451,929
Trans, Comm, Pub Util	4,932,006	4,056,076	3,270,630	3,632,232	15,890,944
Wholesale	79,538	111,864	145,387	157,465	494,254
Retail	20,062,767	18,246,087	19,174,865	18,669,361	76,153,080
Finance, Ins, RE	1,480,683	1,494,804	1,373,022	1,252,833	5,601,342
Services	3,732,984	4,727,913	5,965,690	4,369,744	18,796,331
Government	0	0	0	0	0
<b>Total</b>	<b>31,093,476</b>	<b>29,801,554</b>	<b>31,351,738</b>	<b>29,065,451</b>	<b>121,312,219</b>
<b>2004</b>					
Ag, Forestry, Fishing	97,275	159,363	351,638	110,139	718,415
Mining	63,827	57,575	75,540	66,021	262,963
Construction	270,414	294,583	308,561	278,839	1,152,397
Manufacturing	508,762	803,910	1,023,087	517,323	2,853,082
Trans, Comm, Pub Util	3,939,435	3,467,903	3,197,445	3,489,473	14,094,256
Wholesale	152,309	127,610	109,725	84,072	473,716
Retail	19,316,910	25,145,460	26,970,841	22,762,745	94,195,956
Finance, Ins, RE	1,256,343	1,345,408	1,362,338	1,245,035	5,209,124
Services	3,940,716	4,850,846	6,631,650	4,247,858	19,671,070
Government	0	0	0	0	0
<b>Total</b>	<b>29,545,991</b>	<b>36,252,658</b>	<b>40,030,825</b>	<b>32,801,505</b>	<b>138,630,979</b>
<b>2005</b>					
				<b>Year to Date</b>	
Ag, Forestry, Fishing	141,622	186,963			328,585
Mining	70,218	46,396			116,614
Construction	211,262	309,866			521,128
Manufacturing	436,084	699,476			1,135,560
Trans, Comm, Pub Util	3,905,313	3,195,056			7,100,369
Wholesale	90,018	126,121			216,139
Retail	19,579,438	26,623,174			46,202,612
Finance, Ins, RE	1,152,812	1,210,927			2,363,739
Services	3,906,565	4,882,756			8,789,321
Government	0	0			0
<b>Total</b>	<b>29,493,332</b>	<b>37,280,735</b>	<b>0</b>	<b>0</b>	<b>66,774,067</b>

Table 3.8

# Kenai Construction

<b>Kenai 2nd Quarter Permit VALUES by Type - 1999-2005 - in \$</b>								
	1999	2000	2001	2002	2003	2004	2005	Annual Change
Residential - New	1,573,000	1,606,000	2,886,000	2,362,000	1,943,000	1,079,000	1,883,500	74.6%
Residential - Add/Alter	187,600	439,000	228,300	323,100	515,200	52,200	131,300	151.5%
Commercial - New	61,000	1,045,000	3,744,000	1,480,000	0	81,000	45,000	-44.4%
Commercial - Add/Alter	201,000	73,000	739,600	404,300	270,150	685,200	497,500	-27.4%
<b>TOTAL</b>	<b>2,022,600</b>	<b>3,163,000</b>	<b>7,597,900</b>	<b>4,569,400</b>	<b>2,728,350</b>	<b>1,897,400</b>	<b>2,557,300</b>	<b>34.8%</b>
Annual Change		56.4%	140.2%	-39.9%	-40.3%	-30.5%	34.8%	

Table 3.9

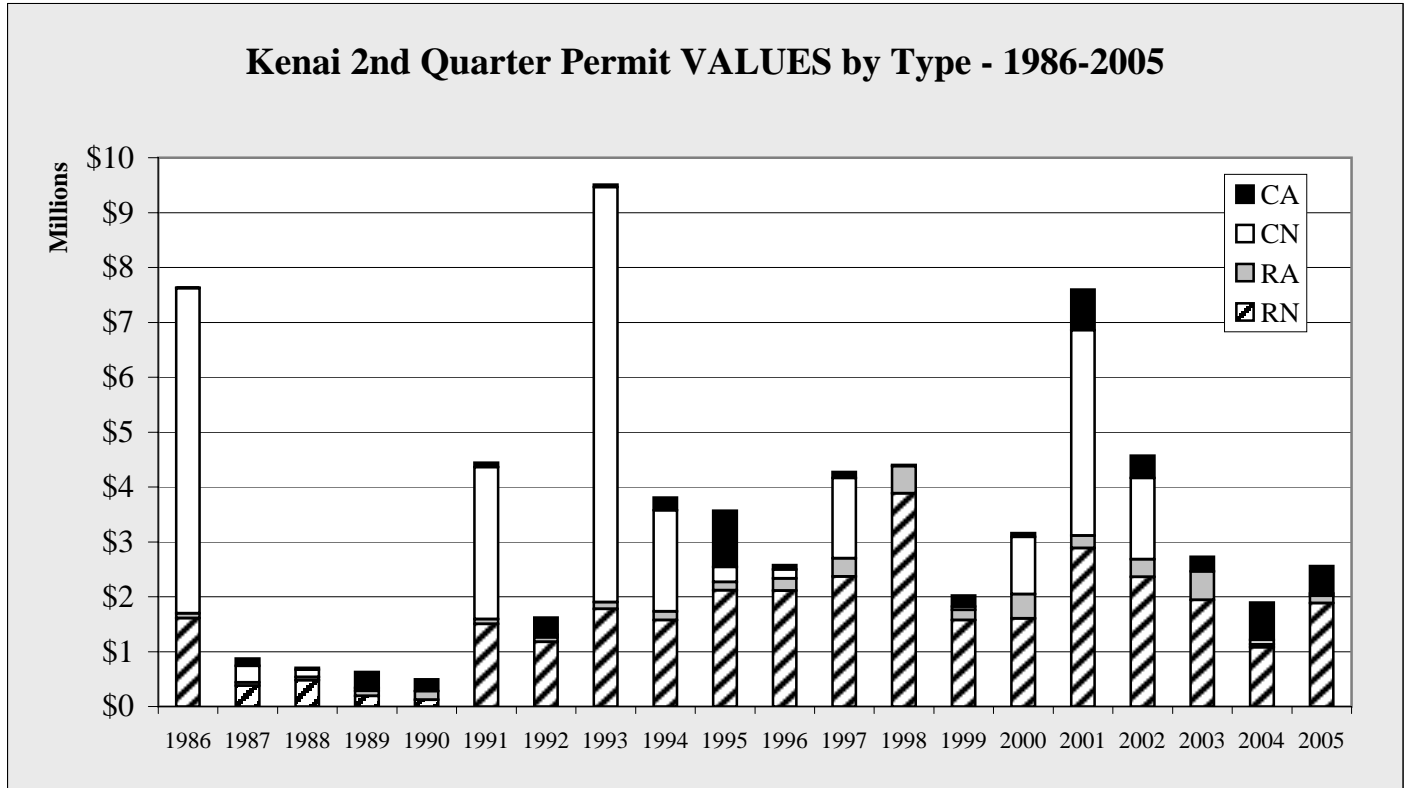

Chart 3.13

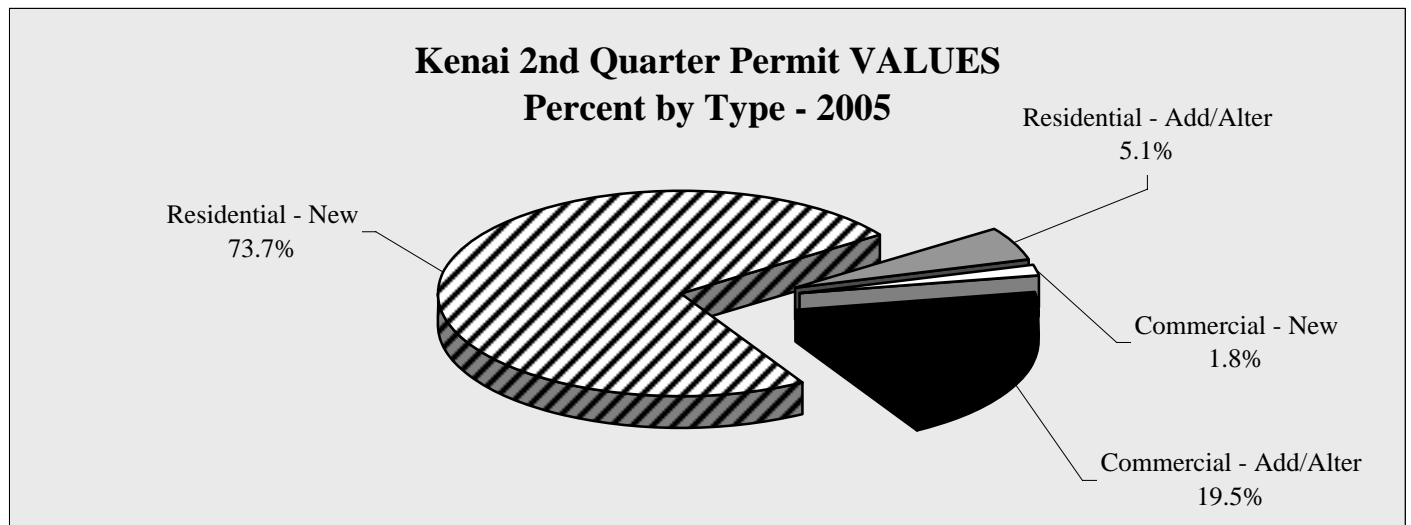

Chart 3.14

# Kenai Construction

**Kenai 2nd Quarter Permit VOLUME by Type - 1999-2005**

	1999	2000	2001	2002	2003	2004	2005	Annual Change
Residential - New	12	11	16	18	13	5	11	120.0%
Residential - Add/Alter	13	18	13	14	16	8	11	37.5%
Commercial - New	1	4	3	3	0	2	2	0.0%
Commercial - Add/Alter	7	3	10	2	11	15	9	-40.0%
<b>TOTAL</b>	<b>33</b>	<b>36</b>	<b>42</b>	<b>37</b>	<b>40</b>	<b>30</b>	<b>33</b>	<b>10.0%</b>
Annual Change		9.1%	16.7%	-11.9%	8.1%	-25.0%	10.0%	

Table 3.10

**Kenai 2nd Quarter Permit VOLUME by Type - 1986-2005**

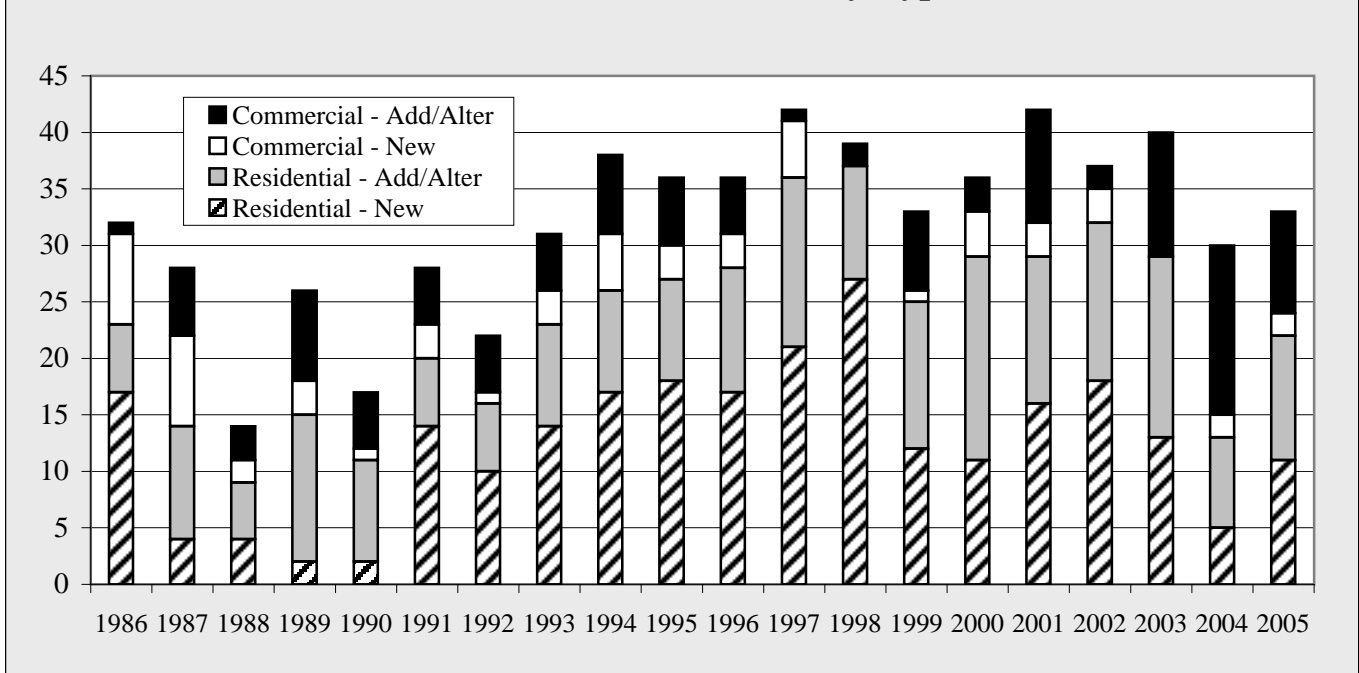

Chart 3.15

**Kenai 2nd Quarter Permit VOLUME  
Percent by Type - 2005**

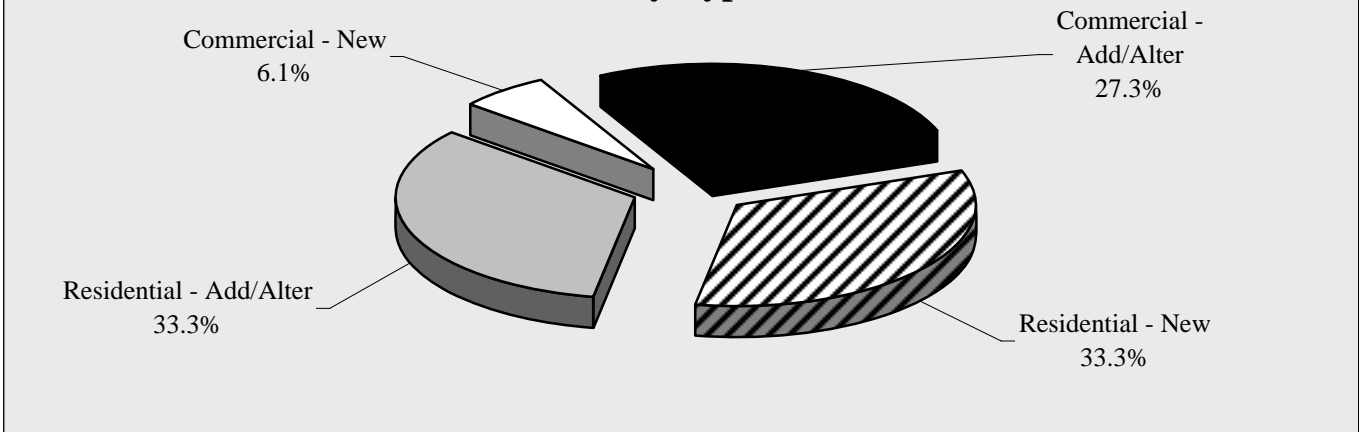

Chart 3.16

# Kenai Construction

Kenai YTD 6/30 Permit VALUES by Type - 1999-2005 - in \$								
	1999	2000	2001	2002	2003	2004	2005	Annual Change
Residential - New	1,573,000	1,834,000	3,509,000	2,641,000	1,943,000	1,379,000	1,883,500	36.6%
Residential - Add/Alter	309,600	446,000	389,800	351,100	530,200	64,200	265,800	314.0%
Commercial - New	75,500	1,110,000	3,759,000	5,059,200	0	81,000	45,000	-44.4%
Commercial - Add/Alter	304,000	235,900	759,600	406,300	1,812,750	685,200	788,500	15.1%
<b>TOTAL</b>	<b>2,262,100</b>	<b>3,625,900</b>	<b>8,417,400</b>	<b>8,457,600</b>	<b>4,285,950</b>	<b>2,209,400</b>	<b>2,982,800</b>	<b>35.0%</b>
Annual Change		60.3%	132.1%	0.5%	-49.3%	-48.5%	35.0%	

Table 3.11

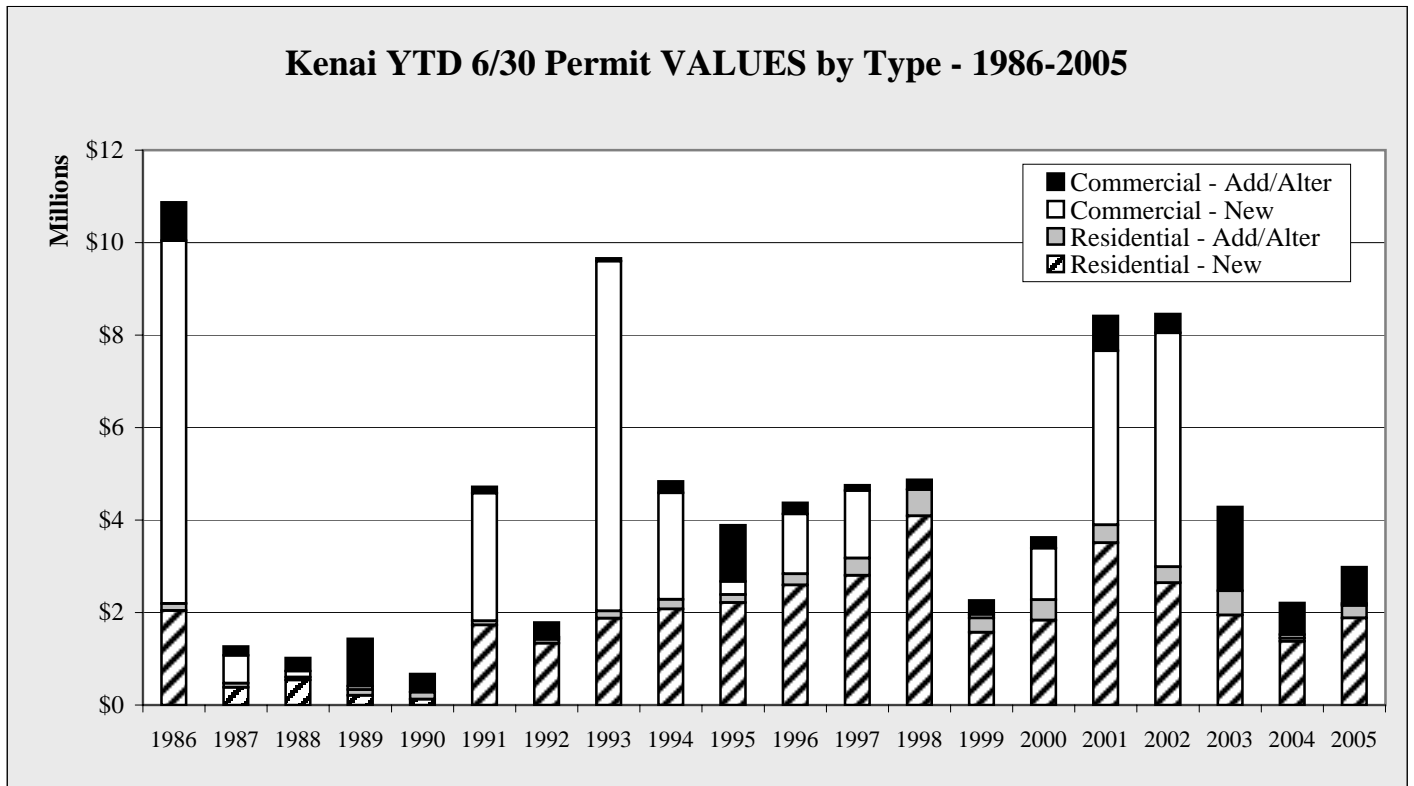

Chart 3.17

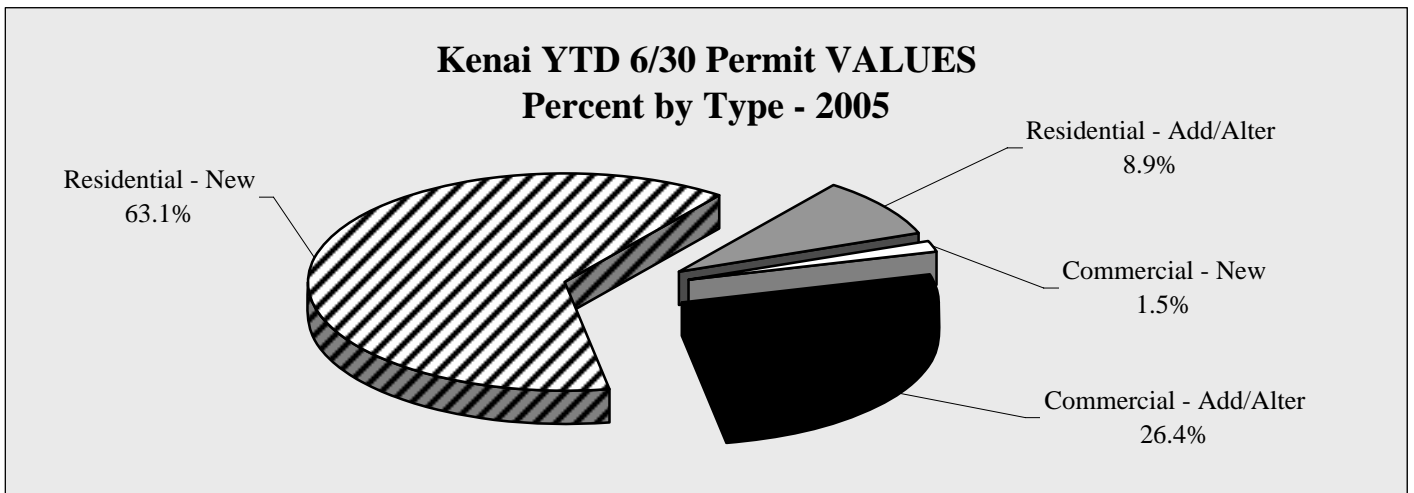

Chart 3.18

# Kenai Construction

**Kenai YTD 6/30 Permit VOLUME by Type - 1999-2005**

	1999	2000	2001	2002	2003	2004	2005	Annual Change
Residential - New	12	12	20	20	13	8	11	37.5%
Residential - Add/Alter	16	20	18	15	17	9	18	100.0%
Commercial - New	2	5	4	4	0	2	2	0.0%
Commercial - Add/Alter	10	7	11	3	18	15	12	-20.0%
<b>TOTAL</b>	<b>40</b>	<b>44</b>	<b>53</b>	<b>42</b>	<b>48</b>	<b>34</b>	<b>43</b>	<b>26.5%</b>
Annual Change		10.0%	20.5%	-20.8%	14.3%	-29.2%	26.5%	

Table 3.12

**Kenai YTD 6/30 Permit VOLUME by Type - 1986-2005**

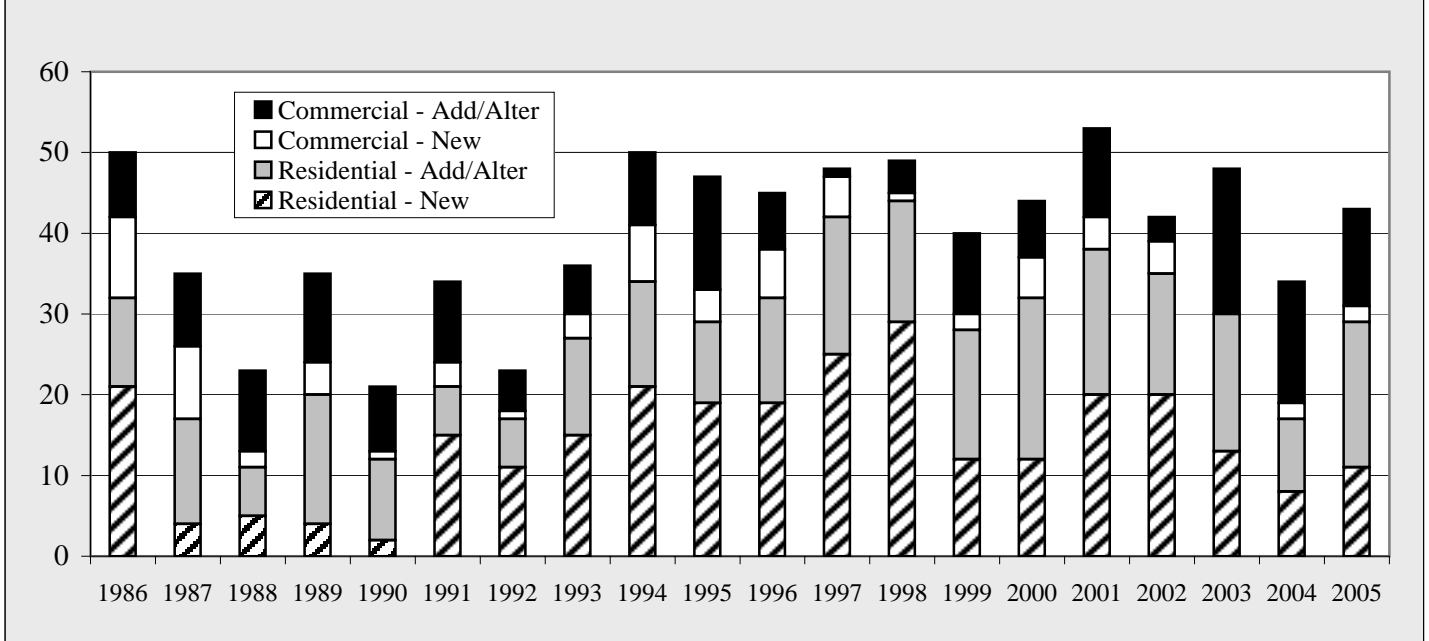

Chart 3.19

**Kenai YTD 6/30 Permit VOLUME  
Percent by Type - 2005**

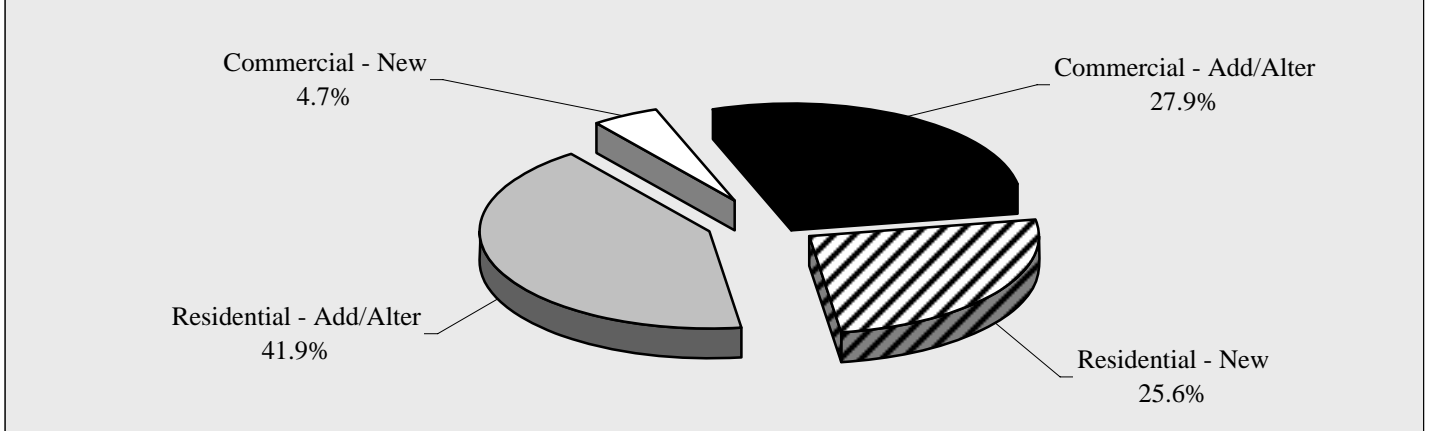

Chart 3.20

# Kenai Construction

<b>Kenai Annual Permit VALUES by Type by Quarter - 1998-2005 - in \$</b>					
	1st Quarter	2nd Quarter	3rd Quarter	4th Quarter	Total
<b>1998</b>					
Residential - New	208,500	3,884,500	1,524,500	416,000	6,033,500
Residential - Add/Alter	68,500	495,500	122,900	43,800	730,700
Commercial - New	7,000	0	95,000	49,000	151,000
Commercial - Add/Alter	186,500	21,500	432,500	86,500	727,000
<b>TOTAL</b>	<b>470,500</b>	<b>4,401,500</b>	<b>2,174,900</b>	<b>595,300</b>	<b>7,642,200</b>
<b>1999</b>					
Residential - New	0	1,573,000	1,049,000	702,000	3,324,000
Residential - Add/Alter	122,000	187,600	267,000	221,400	798,000
Commercial - New	14,500	61,000	4,597,250	125,000	4,797,750
Commercial - Add/Alter	103,000	201,000	209,400	8,600	522,000
<b>TOTAL</b>	<b>239,500</b>	<b>2,022,600</b>	<b>6,122,650</b>	<b>1,057,000</b>	<b>9,441,750</b>
<b>2000</b>					
Residential - New	228,000	1,606,000	1,287,000	376,000	3,497,000
Residential - Add/Alter	7,000	439,000	387,000	55,400	888,400
Commercial - New	65,000	1,045,000	2,896,000	244,000	4,250,000
Commercial - Add/Alter	162,900	73,000	524,000	2,800	762,700
<b>TOTAL</b>	<b>462,900</b>	<b>3,163,000</b>	<b>5,094,000</b>	<b>678,200</b>	<b>9,398,100</b>
<b>2001</b>					
Residential - New	623,000	2,886,000	1,152,000	324,000	4,985,000
Residential - Add/Alter	161,500	228,300	217,500	67,800	675,100
Commercial - New	15,000	3,744,000	1,406,700	214,000	5,379,700
Commercial - Add/Alter	20,000	739,600	1,730,000	49,500	2,539,100
<b>TOTAL</b>	<b>819,500</b>	<b>7,597,900</b>	<b>4,506,200</b>	<b>655,300</b>	<b>13,578,900</b>
<b>2002</b>					
Residential - New	279,000	2,362,000	2,899,000	377,000	5,917,000
Residential - Add/Alter	28,000	323,100	302,400	70,000	723,500
Commercial - New	3,579,200	1,480,000	212,000	990,000	6,261,200
Commercial - Add/Alter	2,000	404,300	3,400,600	90,800	3,897,700
<b>TOTAL</b>	<b>3,888,200</b>	<b>4,569,400</b>	<b>6,814,000</b>	<b>1,527,800</b>	<b>16,799,400</b>
<b>2003</b>					
Residential - New	0	1,943,000	560,000	779,000	3,282,000
Residential - Add/Alter	15,000	515,200	168,850	183,000	882,050
Commercial - New	0	0	51,000	253,000	304,000
Commercial - Add/Alter	1,542,600	270,150	2,920,500	1,240,500	5,973,750
<b>TOTAL</b>	<b>1,557,600</b>	<b>2,728,350</b>	<b>3,700,350</b>	<b>2,455,500</b>	<b>10,441,800</b>
<b>2004</b>					
Residential - New	300,000	1,079,000	1,197,500	482,000	3,058,500
Residential - Add/Alter	12,000	52,200	308,950	27,000	400,150
Commercial - New	0	81,000	250,000	0	331,000
Commercial - Add/Alter	0	685,200	235,300	76,400	996,900
<b>TOTAL</b>	<b>312,000</b>	<b>1,897,400</b>	<b>1,991,750</b>	<b>585,400</b>	<b>4,786,550</b>
<b>2005</b>					
					<b>Year to Date</b>
Residential - New	0	1,883,500			1,883,500
Residential - Add/Alter	134,500	131,300			265,800
Commercial - New	0	45,000			45,000
Commercial - Add/Alter	291,000	497,500			788,500
<b>TOTAL</b>	<b>425,500</b>	<b>2,557,300</b>			<b>2,982,800</b>

Table 3.13

# Kenai Construction

<b>Kenai Annual Permit VOLUME by Type by Quarter - 1998-2005</b>					
	1st Quarter	2nd Quarter	3rd Quarter	4th Quarter	Total
<b>1998</b>					
Residential - New	2	27	13	3	45
Residential - Add/Alter	5	10	13	5	33
Commercial - New	1	0	1	2	4
Commercial - Add/Alter	2	2	3	8	15
<b>TOTAL</b>	<b>10</b>	<b>39</b>	<b>30</b>	<b>18</b>	<b>97</b>
<b>1999</b>					
Residential - New	0	12	7	7	26
Residential - Add/Alter	3	13	12	13	41
Commercial - New	1	1	10	1	13
Commercial - Add/Alter	3	7	11	1	22
<b>TOTAL</b>	<b>7</b>	<b>33</b>	<b>40</b>	<b>22</b>	<b>102</b>
<b>2000</b>					
Residential - New	1	11	11	3	26
Residential - Add/Alter	2	18	18	7	45
Commercial - New	1	4	4	2	11
Commercial - Add/Alter	4	3	3	1	11
<b>TOTAL</b>	<b>8</b>	<b>36</b>	<b>36</b>	<b>13</b>	<b>93</b>
<b>2001</b>					
Residential - New	4	16	8	2	30
Residential Add/Alter	5	13	8	5	31
Commercial - New	1	3	3	1	8
Commercial - Add/Alter	1	10	4	3	18
<b>TOTAL</b>	<b>11</b>	<b>42</b>	<b>23</b>	<b>11</b>	<b>87</b>
<b>2002</b>					
Residential - New	2	18	19	3	42
Residential Add/Alter	1	14	26	4	45
Commercial - New	1	3	2	3	9
Commercial - Add/Alter	1	2	12	10	25
<b>TOTAL</b>	<b>5</b>	<b>37</b>	<b>59</b>	<b>20</b>	<b>121</b>
<b>2003</b>					
Residential - New	0	13	3	6	22
Residential Add/Alter	1	16	22	5	44
Commercial - New	0	0	2	2	4
Commercial - Add/Alter	7	11	18	8	44
<b>TOTAL</b>	<b>8</b>	<b>40</b>	<b>45</b>	<b>21</b>	<b>114</b>
<b>2004</b>					
Residential - New	3	5	8	4	20
Residential Add/Alter	1	8	12	4	25
Commercial - New	0	2	1	0	3
Commercial - Add/Alter	0	15	10	6	31
<b>TOTAL</b>	<b>4</b>	<b>30</b>	<b>31</b>	<b>14</b>	<b>79</b>
<b>2005</b>					<b>Year to Date</b>
Residential - New	0	11			11
Residential Add/Alter	7	11			18
Commercial - New	0	2			2
Commercial - Add/Alter	3	9			12
<b>TOTAL</b>	<b>10</b>	<b>33</b>			<b>43</b>

Table 3.14



# Kenai Cost of Food

Cost of food data is collected by the University of Alaska, Fairbanks Cooperative Extension. Each quarter the Cooperative Extension surveys up to three grocers in communities throughout the state to determine the cost of food for one week. Specific guidelines are presented to the surveyors regarding item size and sale price for 104 items. Because separation of Kenai and Soldotna data would be meaningless, data presented relates to both communities.

KENAI/SOLDOTNA										
	Jun-97	Jun-98	Jun-99	Jun-00	Jun-01	Jun-02	Jun-03	Jun-04	Jun-05	Annual Change
Sales Tax (in percent)	5.0	5.0	5.0	5.0	5.0	5.0	5.0	5.0	5.0	
Percent of Food Unavailable	0.0	0.0	0.0	1.0	0.0	0.0	1.0	0.0	0.0	
Child, 1 year	15.60	15.92	16.83	16.50	17.49	17.56	17.2	19.25	19.0	-2.3%
Child, 2 years	0.00	0.00	0.00	0.00	0.00	17.56	17.1	18.87	18.8	-2.7%
Children 3-5 years of age	17.10	17.46	18.42	18.13	17.49	19.31	19.7	20.73	20.8	2.2%
Children 6-8 years of age	22.69	23.23	24.54	24.15	25.50	25.68	26.5	27.71	28.0	3.1%
Children 9-11 years of age	25.79	26.32	27.81	27.33	28.90	29.09	30.9	31.22		6.2%
Males 12-14 years of age	29.16	29.76	31.36	30.94	32.71	32.94	33.8	35.36	35.6	2.5%
Males 15-19 years of age	30.06	30.62	32.24	31.97	33.76	33.98	35.1	36.31	36.7	3.2%
Males 20-50 years of age	29.84	30.53	31.98	31.71	33.50	33.80	35.0	36.11	36.7	3.6%
Males 51 and older	28.52	29.16	30.47	30.25	31.85	32.05	33.0	34.38	34.9	2.9%
Females 12-19 years of age	25.11	25.63	27.02	26.64	28.19	28.38	28.5	30.47	30.7	0.5%
Females 20-50 years of age	26.21	26.75	27.90	27.76	29.24	29.43	29.9	31.46	31.9	1.6%
Females 51 and older	25.39	25.89	27.10	26.98	28.54	28.64	29.6	30.61	31.0	3.4%
Family of 2, 20-50 years of age	61.66	63.05	65.90	65.40	69.00	69.56	71.4	74.33	75.5	2.7%
Family of 2, 51 years and older	59.30	60.55	63.33	62.99	66.43	66.76	68.9	71.47	72.5	3.1%
Family of 4, children 1-5 years	88.74	90.66	95.13	94.10	99.36	100.10	101.8	107.17	108.2	1.6%
Family of 4, children 6-11 years	104.52	106.83	112.23	110.94	117.13	118.00	122.3	126.50	128.0	3.6%
Electricity, 1000 kWh	111.00	120.65	120.65	102.98	111.90	118.37	123.1	100.82	131.5	4.0%
Gasoline, auto, 55 gal	76.95	76.18	74.25	90.75	98.45	87.45	97.4	116.60	128.2	11.3%
Lumber, 2X4X8'	3.76	3.22	4.10	3.38	3.68	3.40	3.0	3.43	3.3	-10.9%
Propane, 100 lb. refill	39.48	36.68		42.48	43.42	43.42	48.1	49.09	59.0	10.9%
Sewer & Water, monthly	41.29	41.29								

Table 3.16

# Kenai Cost of Food

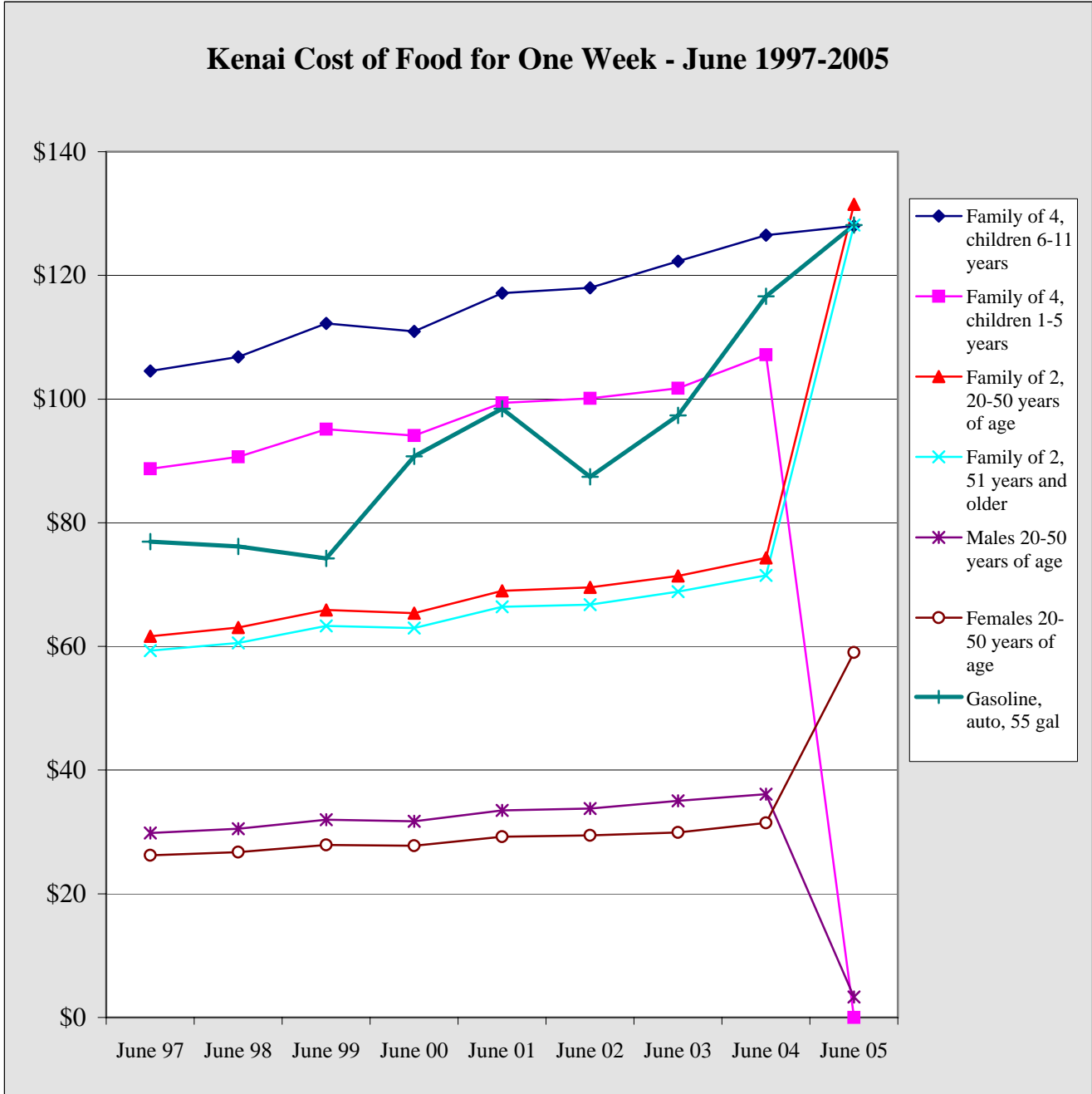

Chart 3.21

# Kenai Population

## Kenai Select Census Detail - 1990 v 2000

<b>Population</b>					<b>Housing</b>				
	1990	2000	Percent Change	Percent of Total		1990	2000	Percent Change	Percent of Total
Total Population	6,327	6,942	9.7%	100.0%	<b>Total Households</b>	2,329	2,622	12.6%	100.0%
Male	3,269	3,430	4.9%	49.4%	Family Households	1,626	1,787	9.9%	68.2%
Female	3,058	3,512	14.8%	50.6%	With Children Under 18	NA	1,066	NA	40.7%
Under 5 years	673	554	-17.7%	8.0%	Married Couple Family	1,294	1,325	2.4%	50.5%
5 to 9 years	615	635	3.3%	9.1%	With Own Children Under 18	NA	703	NA	26.8%
10 to 14 years	471	689	46.3%	9.9%	Female Householder, no husband present	NA	320	NA	12.2%
15 to 19 years	493	577	17.0%	8.3%	With Own Children Under 18	NA	261	NA	10.0%
20 to 24 years	443	356	-19.6%	5.1%	Average Household Size	2.70	2.64	NA	0.1%
25 to 34 years	1,303	899	-31.0%	13.0%	Average Family Size	NA	3.20	NA	0.1%
35 to 44 years	1,065	1,274	19.6%	18.4%	<b>Total Housing Units</b>	2,681	3,003	NA	114.5%
45 to 54 years	624	994	59.3%	14.3%	Occupied Housing Units	2,329	2,622	12.6%	100.0%
55 to 59 years	206	317	53.9%	4.6%	Vacant Housing Units	352	381	8.2%	14.5%
60 to 64 years	175	204	16.6%	2.9%	Seasonal, Recreational, Occasional Use	50	58	16.0%	2.2%
65 to 74 years	207	281	35.7%	4.0%	Owner Vacancy Rate	NA	2.6%	NA	NA
75 to 84 years	41	137	234.1%	2.0%	Rental Vacancy Rate	NA	17.9%	NA	NA
85 years and over	11	25	127.3%	0.4%	Owner Occupied Units	1,270	1,583	24.6%	60.4%
Median Age	28.6	32.3	12.9%	NA	Renter Occupied Units	1,059	1,039	-1.9%	39.6%
18 Years and Over	2,074	4,665	124.9%	NA	<b>Marital Status (over 15)</b>	NA	5,099	NA	NA
Male		2,292	NA	NA	Never married	NA	1,199	NA	23.5%
Female		2,373	NA	NA	Married except separated	NA	2,845	NA	55.8%
65 Years and Over	259	443	71.0%	NA	Separated	NA	106	NA	2.1%
Male		195	NA	NA	Widowed	NA	200	NA	3.9%
Female		248	NA	NA	Divorced	NA	749	NA	14.7%
<b>Place of Birth</b>					<b>Disabled, Noninstitutionalized</b>				
Native Born	6,176	6,777	9.7%	97.6%	Population 5 to 20	NA	1,896	NA	100.0%
Born in Alaska	NA	2,458	NA	35.4%	With a Disability	NA	149	NA	7.9%
Born in other state	NA	4,255	NA	61.3%	Population 21 to 64	NA	3,997	NA	100.0%
Foreign Born	151	159	5.3%	2.3%	With a Disability	NA	297	NA	7.4%
Naturalized Citizen	NA	69	NA	1.0%	Percent Employed	NA	39.5%	NA	0.0%
Not a Citizen	NA	90	NA	1.3%	Without a Disability	NA	3,400	NA	85.1%
					Percent Employed	NA	71.0%	NA	0.0%
<b>Veteran Status</b>					<b>Income in 1999 - Families</b>				
Civilian veterans	815	784	NA	16.7%			Total	1,773	
<b>Educational Attainment</b>					Less than \$10,000	95	85	-10.5%	4.8%
Population 25 years and over				4,212	\$10,000 - \$14,999	78	68	-12.8%	3.8%
Less than 9th grade	118	141	19.5%	3.3%	\$15,000 - \$24,999	165	182	10.3%	10.3%
9th-12th, no diploma	340	350	2.9%	8.3%	\$25,000 - \$34,999	198	233	17.7%	13.1%
High School Diploma	1,347	1,372	1.9%	32.6%	\$35,000 - \$49,999	293	209	-28.7%	11.8%
College, no degree	1,050	1,417	35.0%	33.6%	\$50,000 - \$74,999	438	436	-0.5%	24.6%
Associate Degree	241	256	6.2%	6.1%	\$75,000 - \$99,999	216	310	43.5%	17.5%
Bachelor's Degree	374	469	25.4%	11.1%	\$100,000 - \$149,999	108	190	75.9%	10.7%
Graduate, Profess Degree	178	207	16.3%	4.9%	\$150,000 - \$199,999	48	45	-6.3%	2.5%
Percent HS Grad	87.4%	88.3%	1.0%	NA	\$200,000 or more	NA	15	NA	0.8%
Percent Bachelor's +	15.1%	16.0%	6.0%	NA	Median Income - \$	49,552	56,856	14.7%	NA

Table 3.15

# Seldovia Sales

Seldovia 2nd Quarter GROSS Sales by Industry - 1999-2005 - in \$								
	1999	2000	2001	2002	2003	2004	2005	Annual Change
Ag, Forestry, Fishing	2,605	2,797	3,707	6,306	5,737	11,260	0	-100.0%
Mining	0	0	0	0	0	0	0	NA
Construction	33,314	248,864	287,028	42,719	213,775	763,635	394,967	-48.3%
Manufacturing	8,667	6,644	14,430	5,911	25,326	8,735	36,891	322.3%
Trans, Comm, Pub Util	183,025	163,062	138,629	136,379	135,580	152,078	188,762	24.1%
Wholesale	82,638	22,656	13,490	7,040	17,477	26,237	22,059	-15.9%
Retail	727,459	752,524	758,967	690,215	711,358	722,686	745,371	3.1%
Finance, Ins, RE	32,952	24,750	17,006	8,734	242,188	10,170	424,120	4070.3%
Services	317,528	305,603	240,048	257,751	278,014	276,869	272,455	-1.6%
Total	1,388,188	1,526,900	1,473,305	1,155,055	1,629,455	1,971,670	2,084,625	5.7%
Annual Change		10.0%	-3.5%	-21.6%	41.1%	21.0%	5.7%	

Table 4.1

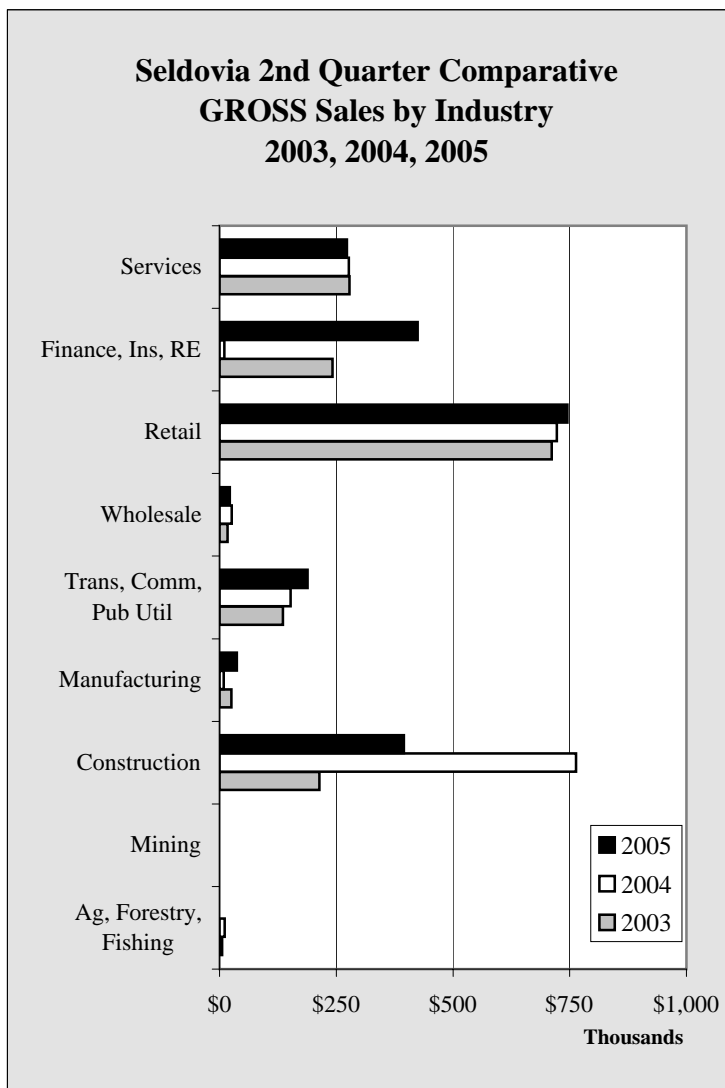

Chart 4.1

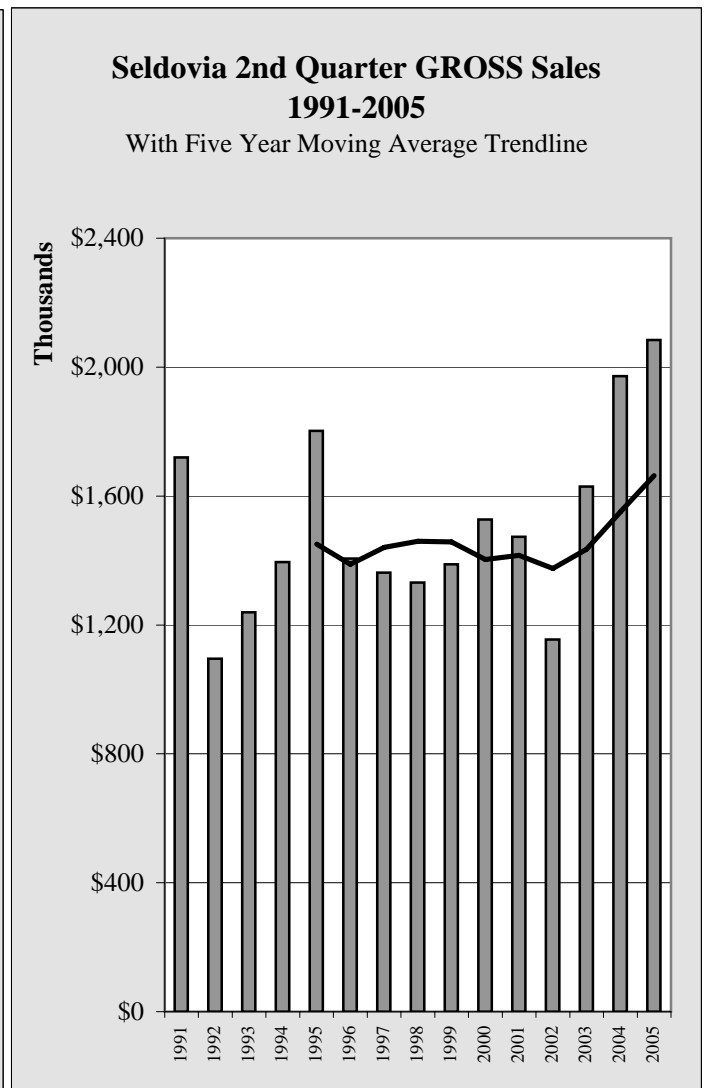

Chart 4.2

# Seldovia Sales

Seldovia 2nd Quarter TAXABLE Sales by Industry - 1999-2005 - in \$								
	1999	2000	2001	2002	2003	2004	2005	Annual Change
Ag, Forestry, Fishing	2,605	2,771	3,616	3,551	2,970	3,140	0	NA
Mining	0	0	0	0	0	0	0	NA
Construction	9,564	11,054	9,498	9,130	9,946	8,058	5,615	-30.3%
Manufacturing	2,478	867	1,243	1,806	1,749	2,135	2,819	32.0%
Trans, Comm, Pub Util	119,047	118,630	94,825	95,299	96,701	105,084	103,684	-1.3%
Wholesale	2,714	2,227	1,305	135	321	137	51	-62.8%
Retail	543,204	631,517	657,146	590,349	620,851	613,360	591,323	-3.6%
Finance, Ins, RE	17,095	8,996	7,434	6,144	9,430	8,540	10,740	25.8%
Services	219,255	242,193	180,966	192,416	220,998	199,135	212,476	6.7%
Total	915,962	1,018,255	956,033	898,830	962,966	939,589	926,708	-1.4%
Annual Change		11.2%	-6.1%	-6.0%	7.1%	-2.4%	-1.4%	

Table 4.2

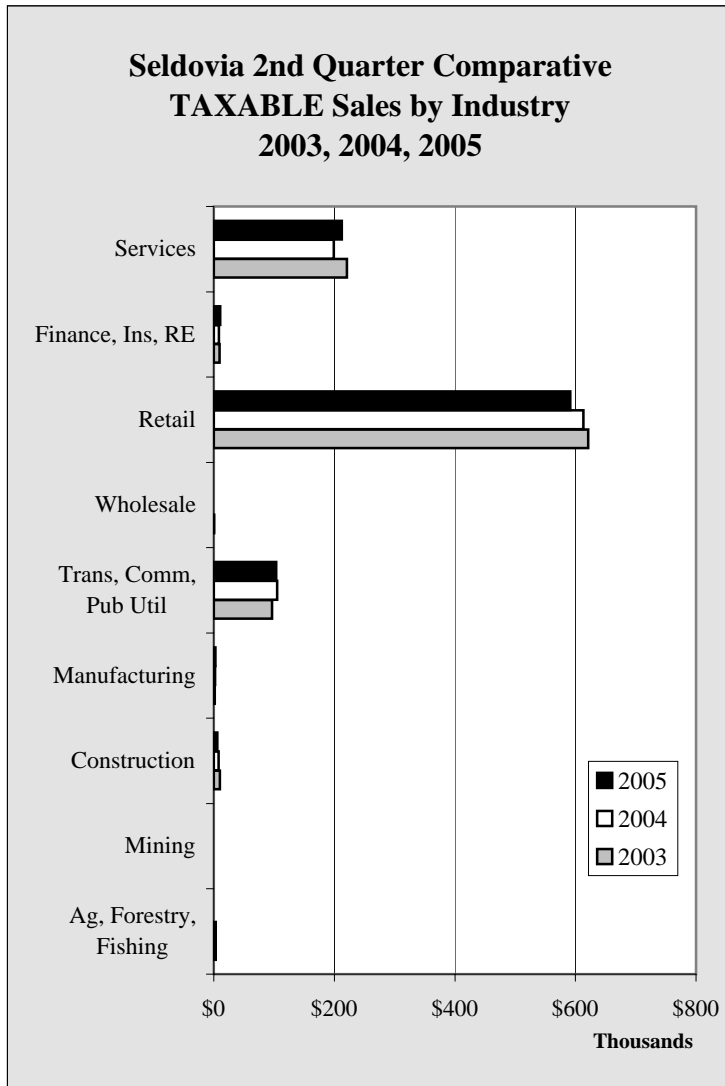

Chart 4.3

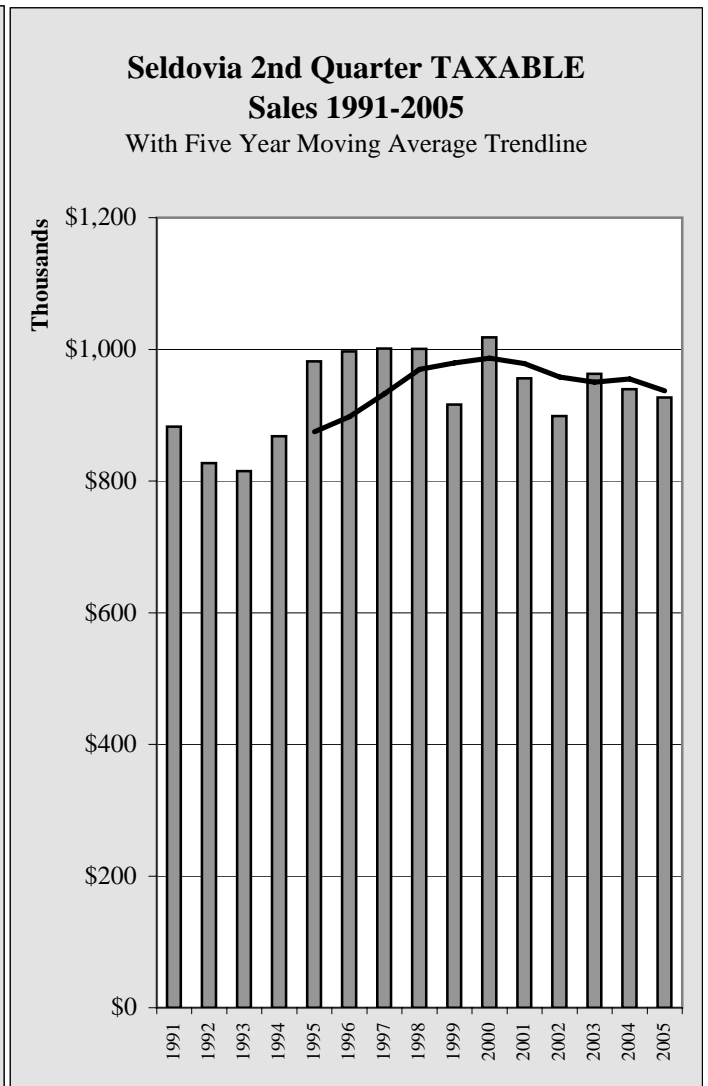

Chart 4.4

# Seldovia Sales

<b>Seldovia YTD 6/30 GROSS Sales by Industry - 1999-2005 - in \$</b>								
	1999	2000	2001	2002	2003	2004	2005	Annual Change
Ag, Forestry, Fishing	2,605	2,797	3,707	6,306	5,737	11,260	0	-100.0%
Mining	0	0	0	0	0	0	0	NA
Construction	45,575	295,708	317,051	109,501	241,722	1,365,011	828,958	-39.3%
Manufacturing	11,894	10,373	17,419	7,615	27,171	9,984	38,222	282.8%
Trans, Comm, Pub Util	371,098	322,429	300,653	299,624	283,329	303,826	349,751	15.1%
Wholesale	337,175	39,417	39,176	10,800	26,678	40,387	34,957	-13.4%
Retail	1,039,762	1,560,185	1,312,363	1,175,694	1,255,678	1,245,323	1,278,695	2.7%
Finance, Ins, RE	71,069	38,813	40,830	167,402	249,278	19,297	440,129	2180.8%
Services	417,068	407,870	340,917	389,825	386,867	381,629	374,980	-1.7%
<b>Total</b>	<b>2,296,246</b>	<b>2,677,592</b>	<b>2,372,116</b>	<b>2,166,767</b>	<b>2,476,460</b>	<b>3,376,717</b>	<b>3,345,692</b>	<b>-0.9%</b>
Annual Change		16.6%	-11.4%	-8.7%	14.3%	36.4%	-0.9%	

Table 4.3

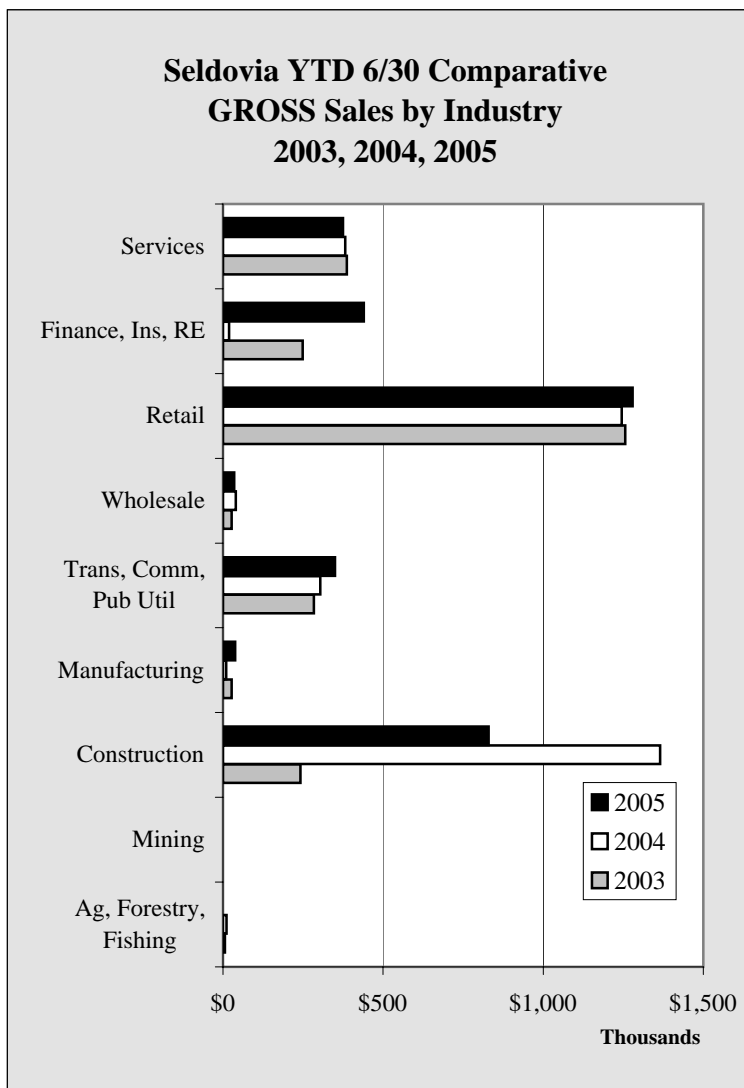

Chart 4.5

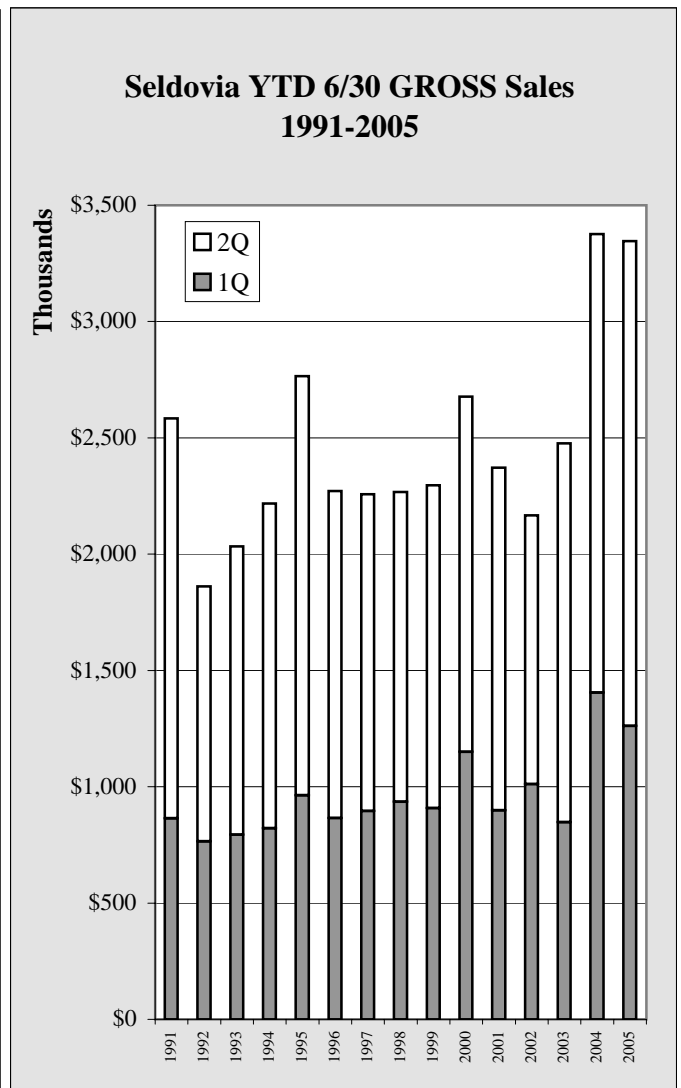

Chart 4.6

# Seldovia Sales

<b>Seldovia YTD 6/30 TAXABLE Sales by Industry - 1999-2005 - in \$</b>								
	1999	2000	2001	2002	2003	2004	2005	Annual Change
Ag, Forestry, Fish	2,605	2,771	3,616	3,551	2,970	3,140	0	-100.0%
Mining	0	0	0	0	0	0	0	NA
Construction	13,925	21,043	17,093	16,110	11,077	13,218	9,770	-26.1%
Manufacturing	3,556	2,576	2,297	3,000	2,117	2,784	3,650	31.1%
Trans, Comm, Pub	232,079	228,935	212,013	210,320	200,393	202,073	205,841	1.9%
Wholesale	100,549	3,230	1,555	294	471	167	126	-24.6%
Retail	818,999	1,001,378	1,049,195	957,765	1,035,907	1,005,601	981,335	-2.4%
Finance, Ins, RE	35,132	17,589	13,823	13,322	14,030	14,482	21,944	51.5%
Services	278,555	309,826	239,996	268,092	294,971	264,850	276,559	4.4%
<b>Total</b>	<b>1,485,400</b>	<b>1,587,348</b>	<b>1,539,588</b>	<b>1,472,454</b>	<b>1,561,936</b>	<b>1,506,315</b>	<b>1,499,225</b>	<b>-0.5%</b>
Annual Change		6.9%	-3.0%	-4.4%	6.1%	-3.6%	-0.5%	

Table 4.4

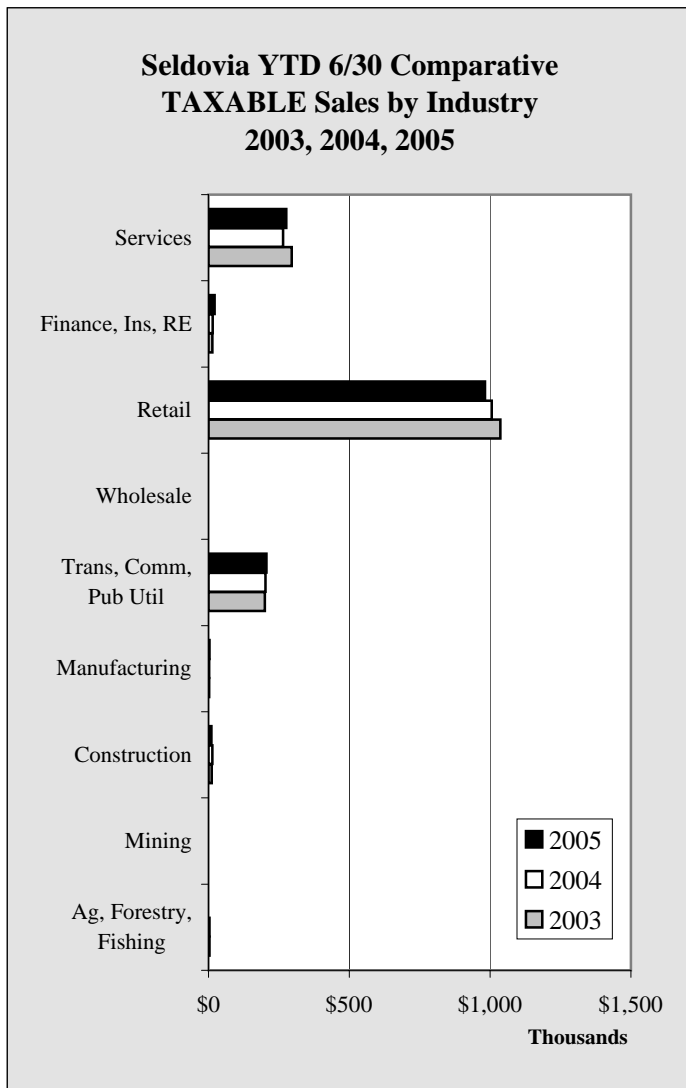

Chart 4.7

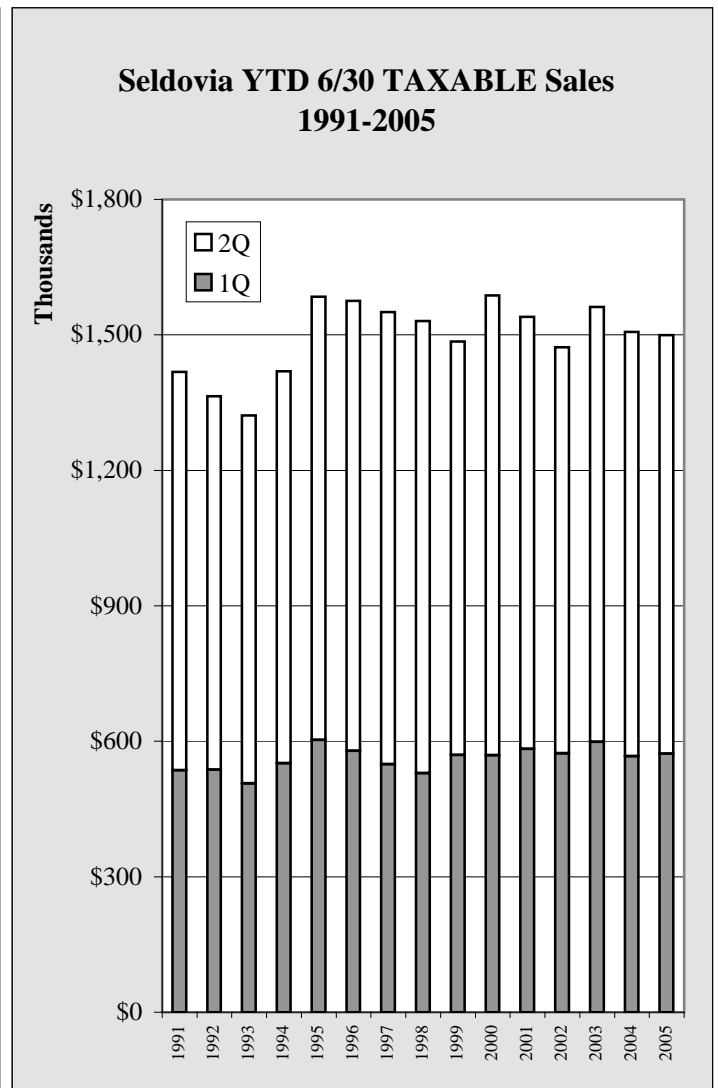

Chart 4.8

# Seldovia Sales

<b>Seldovia Annual GROSS Sales by Industry - 1998-2004 - in \$</b>								
	1998	1999	2000	2001	2002	2003	2004	Annual Change
Ag, Forestry, Fishing	3,422	3,084	2,797	3,787	6,306	5,737	28,760	401.3%
Mining	0	0	0	0	0	0	0	NA
Construction	302,999	200,475	567,881	427,249	233,790	2,235,069	2,432,152	8.8%
Manufacturing	53,202	142,303	22,483	40,983	41,694	44,136	24,563	-44.3%
Trans, Comm, Pub Util	724,009	702,895	642,067	615,305	589,101	609,377	621,624	2.0%
Wholesale	886,557	466,249	74,511	58,140	40,755	143,974	105,348	-26.8%
Retail	1,698,659	2,359,533	2,969,768	2,710,711	2,527,071	2,565,299	2,640,802	2.9%
Finance, Ins, RE	134,421	111,959	62,750	509,244	443,797	590,854	1,446,162	144.8%
Services	920,470	858,272	925,068	884,052	935,363	1,065,108	1,025,790	-3.7%
<b>Total</b>	<b>4,723,739</b>	<b>4,844,770</b>	<b>5,267,325</b>	<b>5,249,471</b>	<b>4,817,877</b>	<b>7,259,554</b>	<b>8,325,201</b>	<b>14.7%</b>
Annual Change		2.6%	8.7%	-0.3%	-8.2%	50.7%	14.7%	

Table 4.5

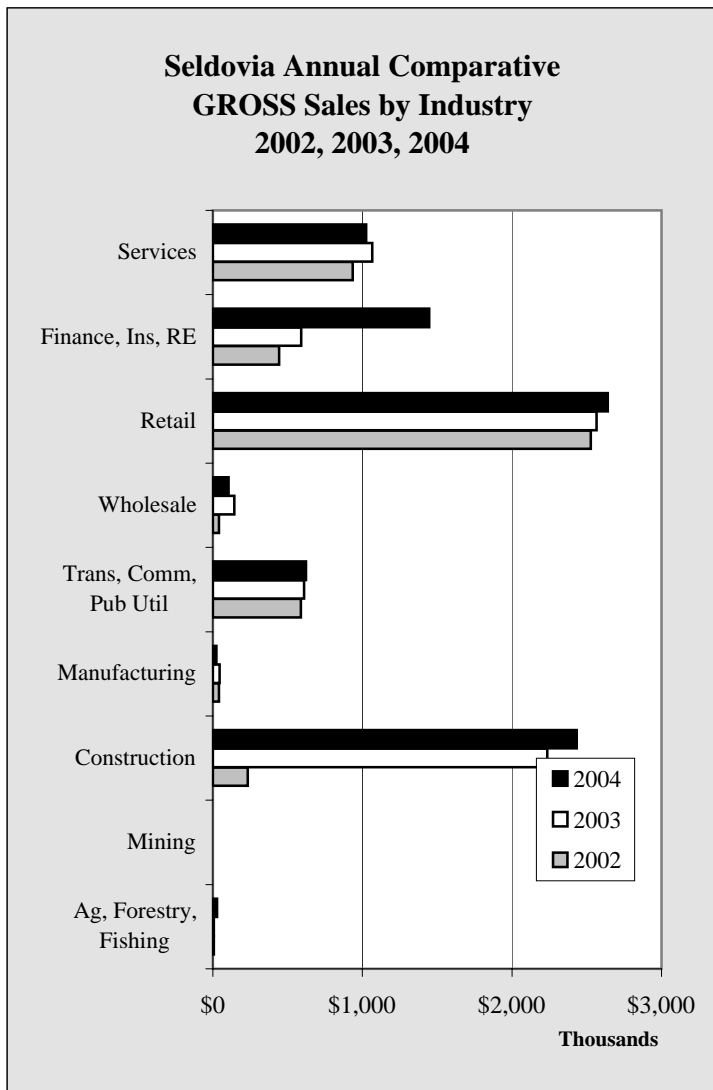

Chart 4.9

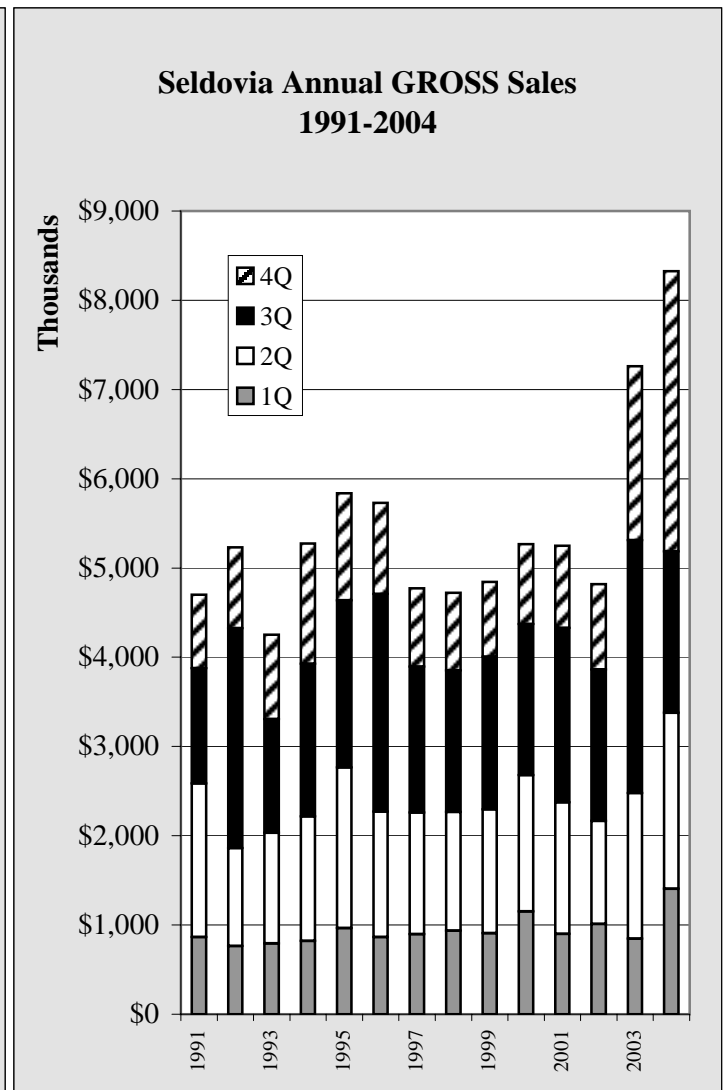

Chart 4.10



# Seldovia Sales

Seldovia Annual TAXABLE Sales by Industry - 1998-2004 - in \$								
	1998	1999	2000	2001	2002	2003	2004	Annual Change
Ag, Forestry, Fishing	3,422	3,084	2,771	3,616	3,551	2,970	3,140	5.7%
Mining	0	0	0	0	0	0	0	NA
Construction	32,244	37,757	41,098	34,175	22,683	26,848	27,088	0.9%
Manufacturing	16,711	7,035	4,892	4,818	6,509	9,098	9,146	0.5%
Trans, Comm, Pub Util	438,292	473,005	455,499	410,584	427,667	450,291	411,317	-8.7%
Wholesale	510,369	106,422	4,692	4,069	945	1,649	426	-74.2%
Retail	1,577,816	1,877,036	2,165,560	2,226,879	2,118,927	2,155,556	2,167,989	0.6%
Finance, Ins, RE	83,118	65,347	28,771	31,657	24,937	29,796	43,310	45.4%
Services	736,321	659,563	714,840	643,481	667,170	700,736	719,266	2.6%
Total	3,398,293	3,229,249	3,418,123	3,359,279	3,272,389	3,376,944	3,381,682	0.1%
Annual Change		-5.0%	5.8%	-1.7%	-2.6%	3.2%	0.1%	

Table 4.6

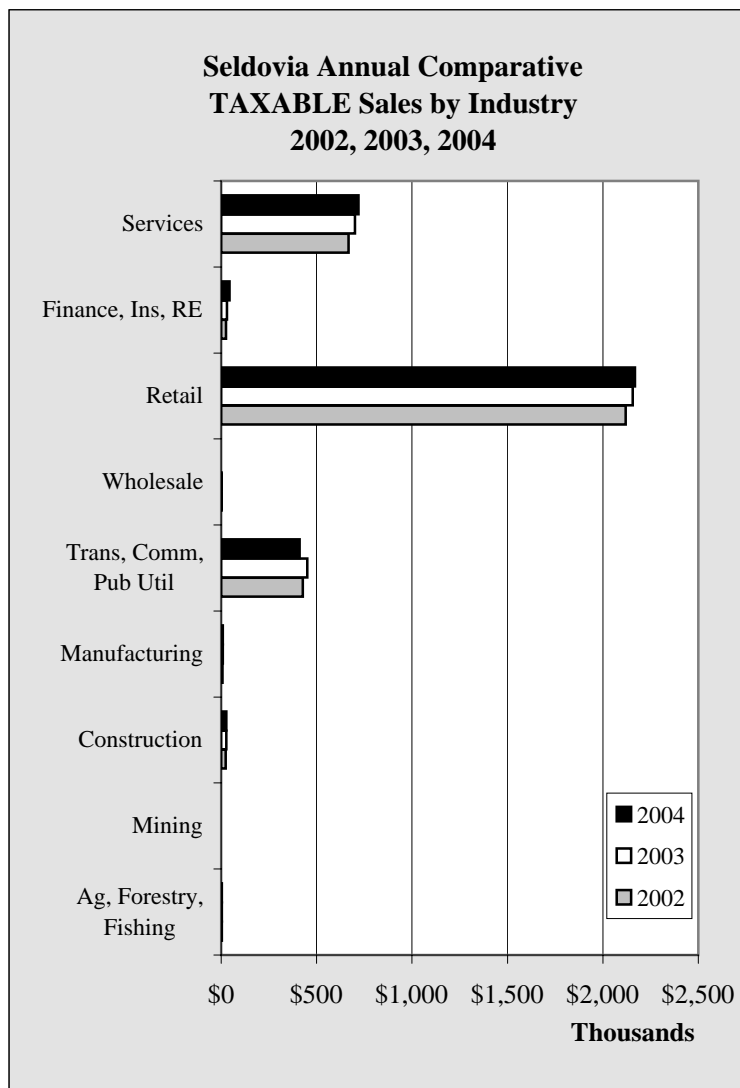

Chart 4.11

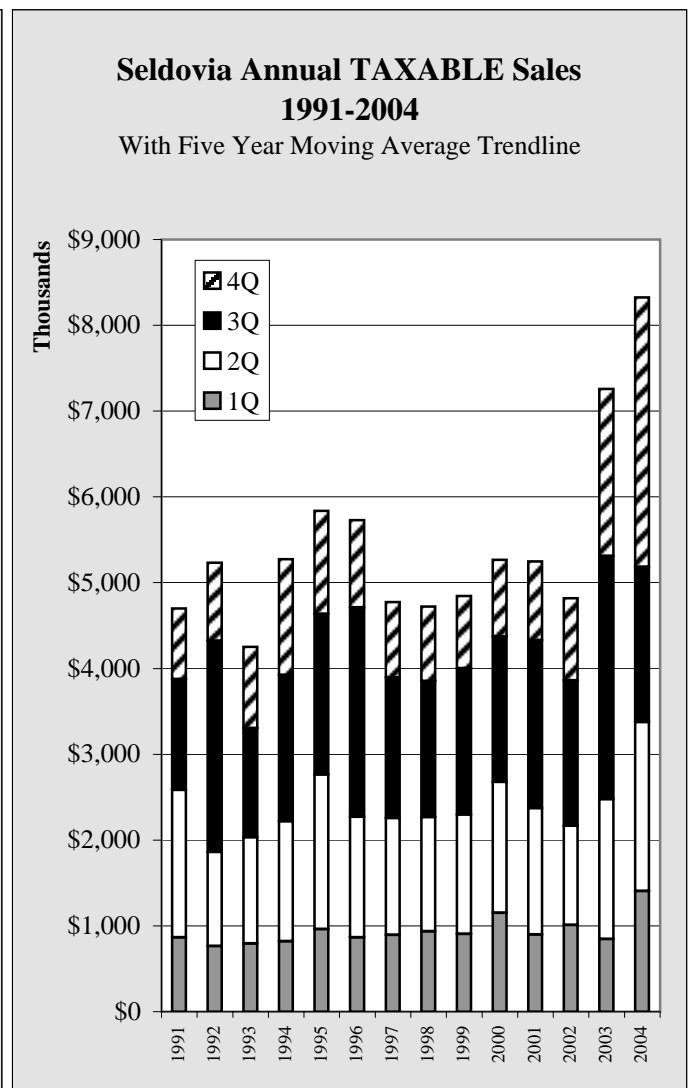

Chart 4.12

# Seldovia Sales

<b>Seldovia GROSS Sales by Industry by Quarter - 2002-2005 - in \$</b>					
	1st Quarter	2nd Quarter	3rd Quarter	4th Quarter	Total
<b>2002</b>					
Ag, Forestry, Fishing	0	6,306	0	0	6,306
Mining	0	0	0	0	0
Construction	66,782	42,719	84,321	39,968	233,790
Manufacturing	1,704	5,911	2,556	31,523	41,694
Trans, Comm, Pub Util	163,245	136,379	137,154	152,323	589,101
Wholesale	3,760	7,040	22,402	7,553	40,755
Retail	485,479	690,215	825,256	526,121	2,527,071
Finance, Ins, RE	158,668	8,734	220,225	56,170	443,797
Services	132,074	257,751	402,260	143,278	935,363
<b>Total</b>	<b>1,011,712</b>	<b>1,155,055</b>	<b>1,694,174</b>	<b>956,936</b>	<b>4,817,877</b>
<b>2003</b>					
Ag, Forestry, Fishing	0	5,737	0	0	5,737
Mining	0	0	0	0	0
Construction	27,947	213,775	1,256,705	736,642	2,235,069
Manufacturing	1,845	25,326	14,320	2,645	44,136
Trans, Comm, Pub Util	147,749	135,580	137,236	188,812	609,377
Wholesale	9,201	17,477	71,441	45,855	143,974
Retail	544,320	711,358	768,860	540,761	2,565,299
Finance, Ins, RE	7,090	242,188	91,073	250,503	590,854
Services	108,853	278,014	494,150	184,091	1,065,108
<b>Total</b>	<b>847,005</b>	<b>1,629,455</b>	<b>2,833,785</b>	<b>1,949,309</b>	<b>7,259,554</b>
<b>2004</b>					
Ag, Forestry, Fishing	0	11,260	17,500	0	28,760
Mining	0	0	0	0	0
Construction	601,376	763,635	360,893	706,248	2,432,152
Manufacturing	1,249	8,735	12,786	1,793	24,563
Trans, Comm, Pub Util	151,748	152,078	168,520	149,278	621,624
Wholesale	14,150	26,237	30,407	34,554	105,348
Retail	522,637	722,686	762,079	633,400	2,640,802
Finance, Ins, RE	9,127	10,170	14,447	1,412,418	1,446,162
Services	104,760	276,869	442,435	201,726	1,025,790
<b>Total</b>	<b>1,405,047</b>	<b>1,971,670</b>	<b>1,809,067</b>	<b>3,139,417</b>	<b>8,325,201</b>
<b>2005</b>					
	<b>Year to Date</b>				
Ag, Forestry, Fishing	0	0			0
Mining	0	0			0
Construction	433,991	394,967			828,958
Manufacturing	1,331	36,891			38,222
Trans, Comm, Pub Util	160,989	188,762			349,751
Wholesale	12,898	22,059			34,957
Retail	533,324	745,371			1,278,695
Finance, Ins, RE	16,009	424,120			440,129
Services	102,525	272,455			374,980
<b>Total</b>	<b>1,261,067</b>	<b>2,084,625</b>	<b>0</b>	<b>0</b>	<b>3,345,692</b>

Table 4.7

# Seldovia Sales

<b>Seldovia TAXABLE Sales by Industry by Quarter - 2002-2005 - in \$</b>					
	1st Quarter	2nd Quarter	3rd Quarter	4th Quarter	Total
<b>2002</b>					
Ag, Forestry, Fishing	0	3,551	0	0	3,551
Mining	0	0	0	0	0
Construction	6,980	9,130	5,551	1,022	22,683
Manufacturing	1,194	1,806	655	2,854	6,509
Trans, Comm, Pub Util	115,021	95,299	106,236	111,111	427,667
Wholesale	159	135	651	0	945
Retail	367,416	590,349	754,759	406,403	2,118,927
Finance, Ins, RE	7,178	6,144	7,535	4,080	24,937
Services	75,676	192,416	316,602	82,476	667,170
<b>Total</b>	<b>573,624</b>	<b>898,830</b>	<b>1,191,989</b>	<b>607,946</b>	<b>3,272,389</b>
<b>2003</b>					
Ag, Forestry, Fishing	0	2,970	0	0	2,970
Mining	0	0	0	0	0
Construction	1,131	9,946	6,900	8,871	26,848
Manufacturing	368	1,749	6,036	945	9,098
Trans, Comm, Pub Util	103,692	96,701	107,036	142,862	450,291
Wholesale	150	321	640	538	1,649
Retail	415,056	620,851	693,503	426,146	2,155,556
Finance, Ins, RE	4,600	9,430	7,783	7,983	29,796
Services	73,973	220,998	318,421	87,344	700,736
<b>Total</b>	<b>598,970</b>	<b>962,966</b>	<b>1,140,319</b>	<b>674,689</b>	<b>3,376,944</b>
<b>2004</b>					
Ag, Forestry, Fishing	0	3,140	0	0	3,140
Mining	0	0	0	0	0
Construction	5,160	8,058	7,520	6,350	27,088
Manufacturing	649	2,135	4,964	1,398	9,146
Trans, Comm, Pub Util	96,989	105,084	118,010	91,234	411,317
Wholesale	30	137	131	128	426
Retail	392,241	613,360	698,936	463,452	2,167,989
Finance, Ins, RE	5,942	8,540	10,589	18,239	43,310
Services	65,715	199,135	341,988	112,428	719,266
<b>Total</b>	<b>566,726</b>	<b>939,589</b>	<b>1,182,138</b>	<b>693,229</b>	<b>3,381,682</b>
<b>2005 Year to Date</b>					
Ag, Forestry, Fishing	0	0			0
Mining	0	0			0
Construction	0	0			0
Manufacturing	4,155	5,615			9,770
Trans, Comm, Pub Util	831	2,819			3,650
Wholesale	102,157	103,684			205,841
Retail	75	51			126
Finance, Ins, RE	390,012	591,323			981,335
Services	11,204	10,740			21,944
<b>Total</b>	<b>508,434</b>	<b>714,232</b>			<b>1,222,666</b>

Table 4.8

# Seldovia Construction

Seldovia 2nd Quarter Permit VALUES by Type - 1999-2005 - in \$								
	1999	2000	2001	2002	2003	2004	2005	Annual Change
Residential - New	105,000	8,000	25,000	0	0	150,000	300,000	100.0%
Residential - Add/Alter	16,500	14,300	0	8,000	0	6,200	4,000	-35.5%
Commercial - New	244,000	0	0	0	0	0	8,000	NA
Commercial - Add/Alter	0	0	0	0	0	0	154,000	NA
<b>TOTAL</b>	<b>365,500</b>	<b>22,300</b>	<b>25,000</b>	<b>8,000</b>	<b>0</b>	<b>156,200</b>	<b>466,000</b>	<b>198.3%</b>
Annual Change		-93.9%	12.1%	-68.0%	-100.0%	NA	198.3%	

Table 4.9

Seldovia 2nd Quarter Permit VOLUME by Type - 1999-2005								
	1999	2000	2001	2002	2003	2004	2005	Annual Change
Residential - New	2	2	1	0	0	1	2	100.0%
Residential - Add/Alter	4	1	0	2	0	2	1	-50.0%
Commercial - New	3	0	0	0	0	0	1	NA
Commercial - Add/Alter	0	0	0	0	0	0	2	NA
<b>TOTAL</b>	<b>9</b>	<b>3</b>	<b>1</b>	<b>2</b>	<b>0</b>	<b>3</b>	<b>6</b>	<b>100.0%</b>
Annual Change		-66.7%	-66.7%	100.0%	-100.0%	NA	100.0%	

Table 4.10

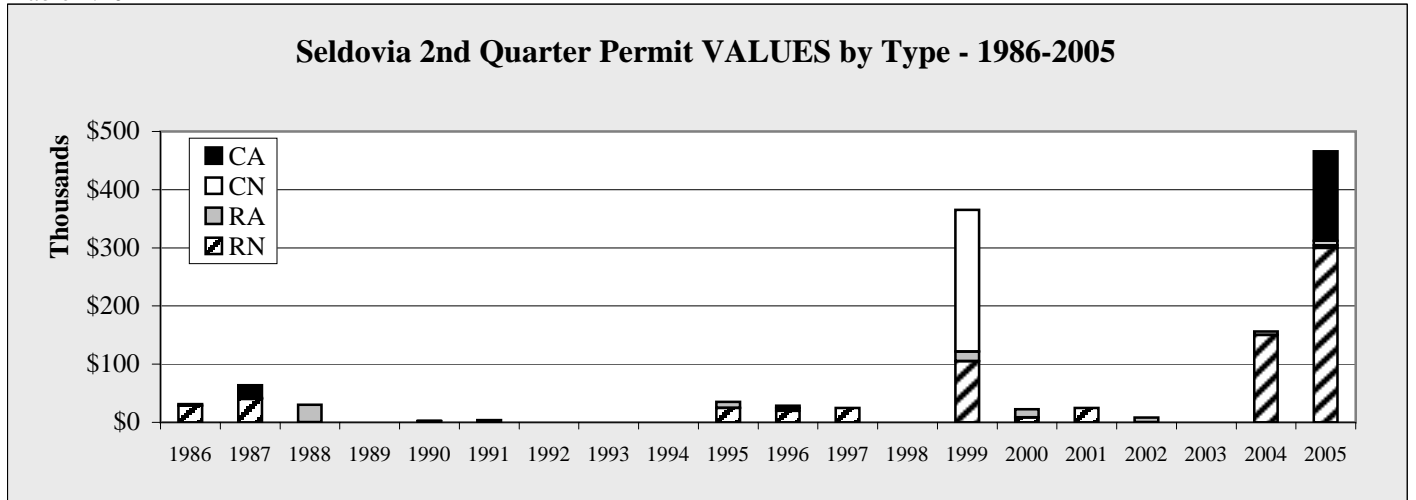

Chart 4.13

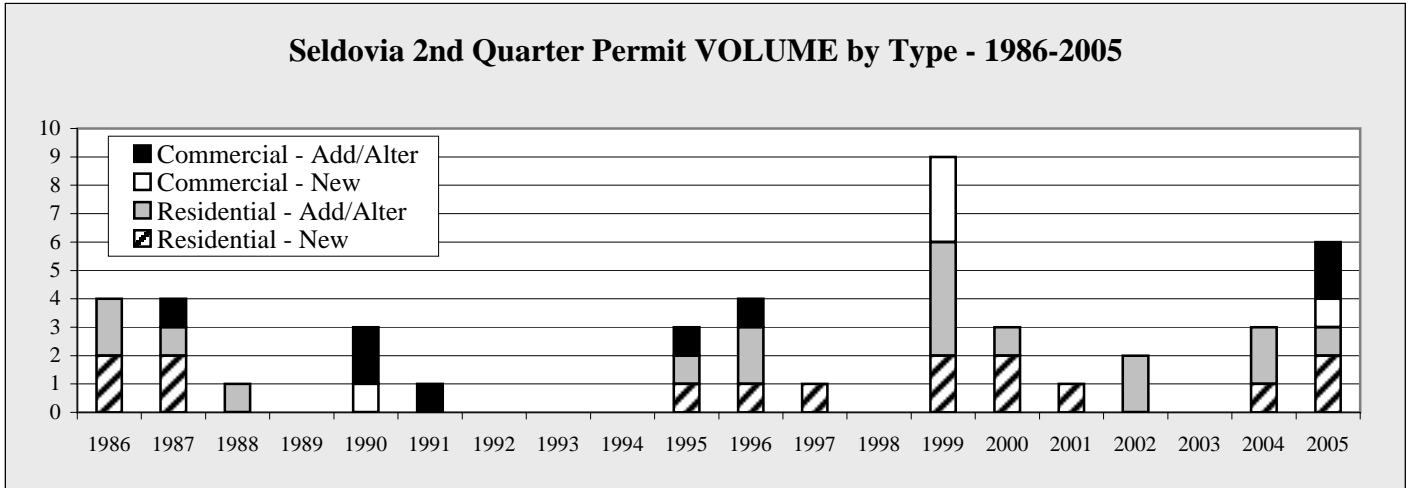

Chart 4.14

# Seldovia Construction

Seldovia YTD 6/30 Permit VALUES by Type - 1999-2005 - in \$								
	1999	2000	2001	2002	2003	2004	2005	Annual Change
Residential - New	105,000	26,000	25,000	0	0	170,000	300,000	76.5%
Residential - Add/Alter	16,500	20,300	0	18,000	31,000	6,200	19,000	206.5%
Commercial - New	252,000	0	0	0	0	0	8,000	NA
Commercial - Add/Alter	0	0	10,000	0	0	0	154,000	NA
<b>TOTAL</b>	<b>373,500</b>	<b>46,300</b>	<b>35,000</b>	<b>18,000</b>	<b>31,000</b>	<b>176,200</b>	<b>481,000</b>	<b>173.0%</b>
Annual Change			-24.4%	-48.6%	72.2%	468.4%	173.0%	

Table 4.11

Seldovia YTD 6/30 Permit VOLUME by Type - 1999-2005								
	1999	2000	2001	2002	2003	2004	2005	Annual Change
Residential - New	2	4	1	0	0	2	2	0.0%
Residential - Add/Alter	4	2	0	3	3	2	2	0.0%
Commercial - New	4	0	0	0	0	0	1	NA
Commercial - Add/Alter	0	0	1	0	0	0	2	NA
<b>TOTAL</b>	<b>10</b>	<b>6</b>	<b>2</b>	<b>3</b>	<b>3</b>	<b>4</b>	<b>7</b>	<b>75.0%</b>
Annual Change		NA	-66.7%	50.0%	0.0%	33.3%	75.0%	

Table 4.12

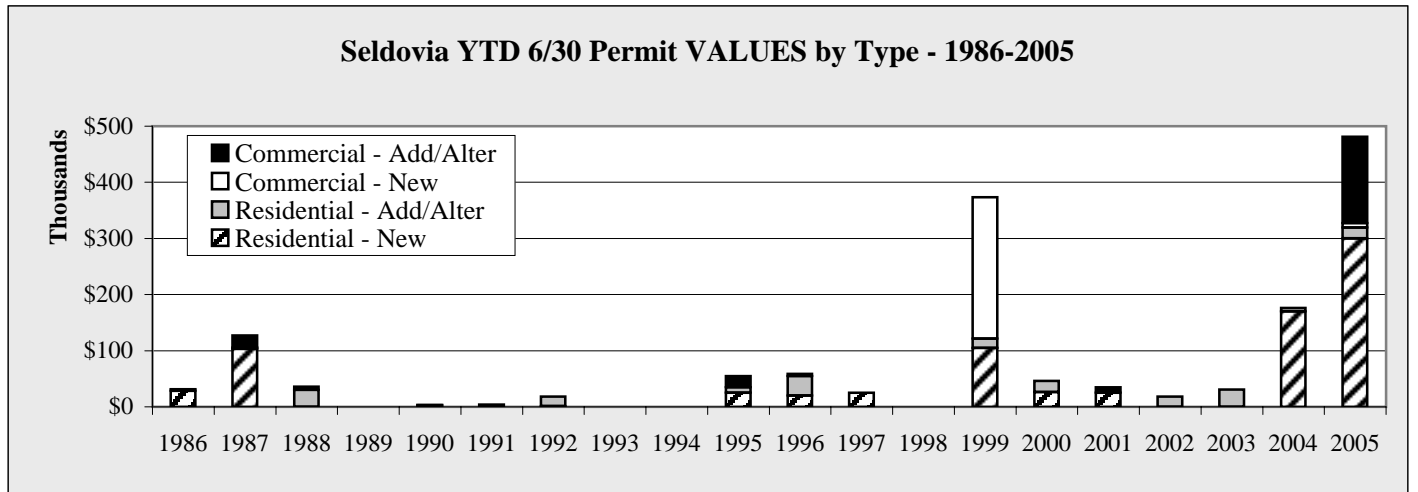

Chart 4.15

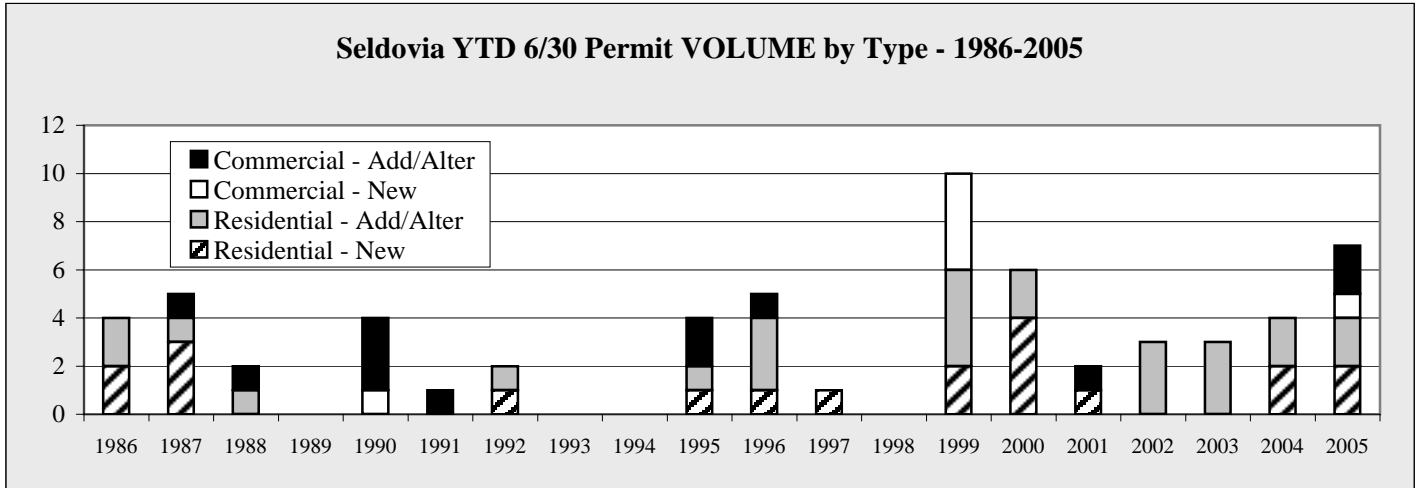

Chart 4.16

# Seldovia Construction

<b>Seldovia Annual Permit VALUES by Type by Quarter - 1999-2005 - in \$</b>					
	1st Quarter	2nd Quarter	3rd Quarter	4th Quarter	Total
<b>1999</b>					
Residential - New	0	105,000	55,000	0	160,000
Residential - Add/Alter	0	16,500	14,500	5,000	36,000
Commercial - New	8,000	244,000	12,000	0	264,000
Commercial - Add/Alter	0	0	6,000	13,000	19,000
<b>TOTAL</b>	<b>8,000</b>	<b>365,500</b>	<b>87,500</b>	<b>18,000</b>	<b>479,000</b>
<b>2000</b>					
Residential - New	18,000	8,000	19,000	0	45,000
Residential - Add/Alter	6,000	14,300	35,400	5,000	60,700
Commercial - New	0	0	0	0	0
Commercial - Add/Alter	0	0	3,500	0	3,500
<b>TOTAL</b>	<b>24,000</b>	<b>22,300</b>	<b>57,900</b>	<b>5,000</b>	<b>109,200</b>
<b>2001</b>					
Residential - New	0	25,000	10,000	0	35,000
Residential - Add/Alter	0	0	5,525	5,000	10,525
Commercial - New	0	0	0	0	0
Commercial - Add/Alter	10,000	0	0	10,000	20,000
<b>TOTAL</b>	<b>10,000</b>	<b>25,000</b>	<b>15,525</b>	<b>15,000</b>	<b>65,525</b>
<b>2002</b>					
Residential - New	0	0	308,000	0	308,000
Residential - Add/Alter	10,000	8,000	10,500	20,000	48,500
Commercial - New	0	0	0	0	0
Commercial - Add/Alter	0	0	0	0	0
<b>TOTAL</b>	<b>10,000</b>	<b>8,000</b>	<b>318,500</b>	<b>20,000</b>	<b>356,500</b>
<b>2003</b>					
Residential - New	0	0	150,000	26,000	176,000
Residential - Add/Alter	31,000	0	0	3,000	34,000
Commercial - New	0	0	1,685,000	7,500	1,692,500
Commercial - Add/Alter	0	0	0	0	0
<b>TOTAL</b>	<b>31,000</b>	<b>0</b>	<b>1,835,000</b>	<b>36,500</b>	<b>1,902,500</b>
<b>2004</b>					
Residential - New	20,000	150,000	0	0	170,000
Residential - Add/Alter	0	6,200	0	0	6,200
Commercial - New	0	0	0	0	0
Commercial - Add/Alter	0	0	0	0	0
<b>TOTAL</b>	<b>20,000</b>	<b>156,200</b>	<b>0</b>	<b>0</b>	<b>176,200</b>
<b>2005</b>					
				<b>Year to Date</b>	
Residential - New	0	300,000			300,000
Residential - Add/Alter	15,000	4,000			19,000
Commercial - New	0	8,000			8,000
Commercial - Add/Alter	0	154,000			154,000
<b>TOTAL</b>	<b>15,000</b>	<b>466,000</b>			<b>481,000</b>

Table 4.13

# Seldovia Construction

<b>Seldovia Annual Permit VOLUME by Type by Quarter - 1999-2005</b>					
	1st Quarter	2nd Quarter	3rd Quarter	4th Quarter	Total
<b>1999</b>					
Residential - New	0	2	1	0	3
Residential - Add/Alter	0	4	4	1	9
Commercial - New	1	3	1	0	5
Commercial - Add/Alter	0	0	1	2	3
<b>TOTAL</b>	<b>1</b>	<b>9</b>	<b>7</b>	<b>3</b>	<b>20</b>
<b>2000</b>					
Residential - New	2	2	2	0	6
Residential - Add/Alter	1	1	3	1	6
Commercial - New	0	0	0	0	0
Commercial - Add/Alter	0	0	1	0	1
<b>TOTAL</b>	<b>3</b>	<b>3</b>	<b>6</b>	<b>1</b>	<b>13</b>
<b>2001</b>					
Residential - New	0	1	1	0	2
Residential Add/Alter	0	0	4	1	5
Commercial - New	0	0	0	0	0
Commercial - Add/Alter	1	0	0	1	2
<b>TOTAL</b>	<b>1</b>	<b>1</b>	<b>5</b>	<b>2</b>	<b>9</b>
<b>2002</b>					
Residential - New	0	0	2	0	2
Residential Add/Alter	1	2	2	1	6
Commercial - New	0	0	0	0	0
Commercial - Add/Alter	0	0	0	0	0
<b>TOTAL</b>	<b>1</b>	<b>2</b>	<b>4</b>	<b>1</b>	<b>8</b>
<b>2003</b>					
Residential - New	0	0	1	2	3
Residential Add/Alter	3	0	0	1	4
Commercial - New	0	0	3	1	4
Commercial - Add/Alter	0	0	1	0	1
<b>TOTAL</b>	<b>3</b>	<b>0</b>	<b>5</b>	<b>4</b>	<b>12</b>
<b>2004</b>					
Residential - New	1	1	0	0	2
Residential Add/Alter	0	2	0	0	2
Commercial - New	0	0	0	0	0
Commercial - Add/Alter	0	0	0	0	0
<b>TOTAL</b>	<b>1</b>	<b>3</b>	<b>0</b>	<b>0</b>	<b>4</b>
<b>2005</b>					
	<b>Year to Date</b>				
Residential - New	0	2			2
Residential Add/Alter	1	1			2
Commercial - New	0	1			1
Commercial - Add/Alter	0	2			2
<b>TOTAL</b>	<b>1</b>	<b>6</b>			<b>7</b>

Table 4.14

# Seldovia Population

## Seldovia Select Census Detail - 1990 v 2000

<b>Population</b>					<b>Housing</b>				
	1990	2000	Percent Change	Percent of Total		1990	2000	Percent Change	Percent of Total
Total Population	316	286	-9.5%	100.0%	<b>Total Households</b>	129	134	3.9%	100.0%
Male	167	145	-13.2%	50.7%	Family Households	67	71	6.0%	53.0%
Female	149	141	-5.4%	49.3%	With Children Under 18	NA	30	NA	22.4%
Under 5 years	23	15	-34.8%	5.2%	Married Couple Family	54	60	11.1%	44.8%
5 to 9 years	35	21	-40.0%	7.3%	With Own Children Under 18	NA	22	NA	16.4%
10 to 14 years	20	20	0.0%	7.0%	Female Householder, no husband present	NA	10	NA	7.5%
15 to 19 years	23	19	-17.4%	6.6%	With Own Children Under 18	NA	8	NA	6.0%
20 to 24 years	8	7	-12.5%	2.4%	Average Household Size	2.45	2.13	NA	1.6%
25 to 34 years	46	17	-63.0%	5.9%	Average Family Size	NA	2.93	NA	2.2%
35 to 44 years	51	43	-15.7%	15.0%	<b>Total Housing Units</b>	221	232	NA	173.1%
45 to 54 years	45	50	11.1%	17.5%	Occupied Housing Units	129	134	3.9%	100.0%
55 to 59 years	15	29	93.3%	10.1%	Vacant Housing Units	92	98	6.5%	73.1%
60 to 64 years	18	28	55.6%	9.8%	Seasonal, Recreational, Occasional Use	58	81	39.7%	60.4%
65 to 74 years	14	27	92.9%	9.4%	Owner Vacancy Rate	NA	NA	NA	NA
75 to 84 years	12	7	-41.7%	2.4%	Rental Vacancy Rate	NA	24.5%	NA	NA
85 years and over	6	3	-50.0%	1.0%	Owner Occupied Units	78	94	20.5%	70.1%
Median Age	35.5	45.3	27.6%	NA	Renter Occupied Units	51	40	-21.6%	29.9%
18 Years and Over	93	217	133.3%	29.4%	<b>Marital Status (over 15)</b>	NA	235	NA	NA
Male		114	NA	NA	Never married	NA	48	NA	20.4%
Female		103	NA	NA	Married except separated	NA	133	NA	56.6%
65 Years and Over	32	37	15.6%	29.4%	Separated	NA	3	NA	1.3%
Male		22	NA	NA	Widowed	NA	2	NA	0.9%
Female		15	NA	NA	Divorced	NA	49	NA	20.9%
<b>Place of Birth</b>					<b>Disabled, Noninstitutionalized</b>				
Native Born	305	283	-7.2%	NA	Population 5 to 20	NA	68	NA	100.0%
Born in Alaska	NA	106	NA	NA	With a Disability	NA	8	NA	11.8%
Born in other state	NA	177	NA	NA	Population 21 to 64	NA	187	NA	100.0%
Foreign Born	10	8	-20.0%	NA	With a Disability	NA	36	NA	19.3%
Naturalized Citizen	NA	1	NA	NA	Percent Employed	NA	55.6%	NA	0.3%
Not a Citizen	NA	7	NA	NA	Without a Disability	NA	151	NA	80.7%
<b>Veteran Status</b>					Percent Employed	NA	64.2%	NA	0.3%
Civilian veterans	39	49	NA	21.7%	<b>Income in 1999 - Families</b>				
<b>Educational Attainment</b>						Total	66		
Population 25 years and over				2,564	Less than \$10,000	0	NA	NA	NA
Less than 9th grade	8	10	25.0%	0.4%	\$10,000 - \$14,999	9	5	-44.4%	7.6%
9th-12th, no diploma	14	19	35.7%	0.7%	\$15,000 - \$24,999	12	5	-58.3%	7.6%
High School Diploma	64	52	-18.8%	2.0%	\$25,000 - \$34,999	5	6	20.0%	9.1%
College, no degree	46	82	78.3%	3.2%	\$35,000 - \$49,999	14	12	-14.3%	18.2%
Associate Degree	6	6	0.0%	0.2%	\$50,000 - \$74,999	18	15	-16.7%	22.7%
Bachelor's Degree	23	35	52.2%	1.4%	\$75,000 - \$99,999	3	14	366.7%	21.2%
Graduate, Profess Degree	13	10	-23.1%	0.4%	\$100,000 - \$149,999	4	4	0.0%	6.1%
Percent HS Grad	87.4%	86.4%	-1.1%	0.0%	\$150,000 - \$199,999	2	5	150.0%	7.6%
Percent Bachelor's +	20.7%	21.0%	1.4%	0.0%	\$200,000 or more	NA	NA	NA	NA
					Median Income - \$	45,313	58,000	28.0%	NA

Table 4.15



This page intentionally left blank.

# Seward Sales

<b>Seward 2nd Quarter GROSS Sales by Industry - 1999-2005 - in \$</b>								
	1999	2000	2001	2002	2003	2004	2005	Annual Change
Ag, Forestry, Fish	211,247	285,558	170,823	153,308	180,817	271,027	288,152	6.3%
Mining	105,031	144,691	105,401	131,150	49,589	78,789	67,545	-14.3%
Costruction	3,643,178	2,944,466	8,043,831	2,363,700	10,116,956	4,487,357	16,823,172	274.9%
Manufacturing	1,498,102	1,998,984	3,697,117	3,261,062	3,785,614	1,922,115	2,257,300	17.4%
Trans, Comm, Pub Util	3,076,349	4,147,565	3,524,903	3,404,989	3,313,681	3,233,313	3,167,744	-2.0%
Wholesale	1,086,340	901,036	671,328	671,893	682,756	910,240	899,290	-1.2%
Retail	13,298,656	14,348,724	15,137,856	15,310,055	14,977,089	17,943,071	19,624,964	9.4%
Finance, Ins, RE	2,453,806	2,295,798	1,147,228	2,345,636	2,106,421	1,663,066	1,567,281	-5.8%
Services	10,668,616	10,947,215	11,953,791	12,743,583	11,771,230	12,251,822	12,422,129	1.4%
<b>Total</b>	<b>36,041,325</b>	<b>38,014,037</b>	<b>44,452,278</b>	<b>40,385,376</b>	<b>46,984,153</b>	<b>42,760,800</b>	<b>57,117,577</b>	<b>33.6%</b>
Annual Change		5.5%	16.9%	-9.1%	16.3%	-9.0%	33.6%	

Table 5.1

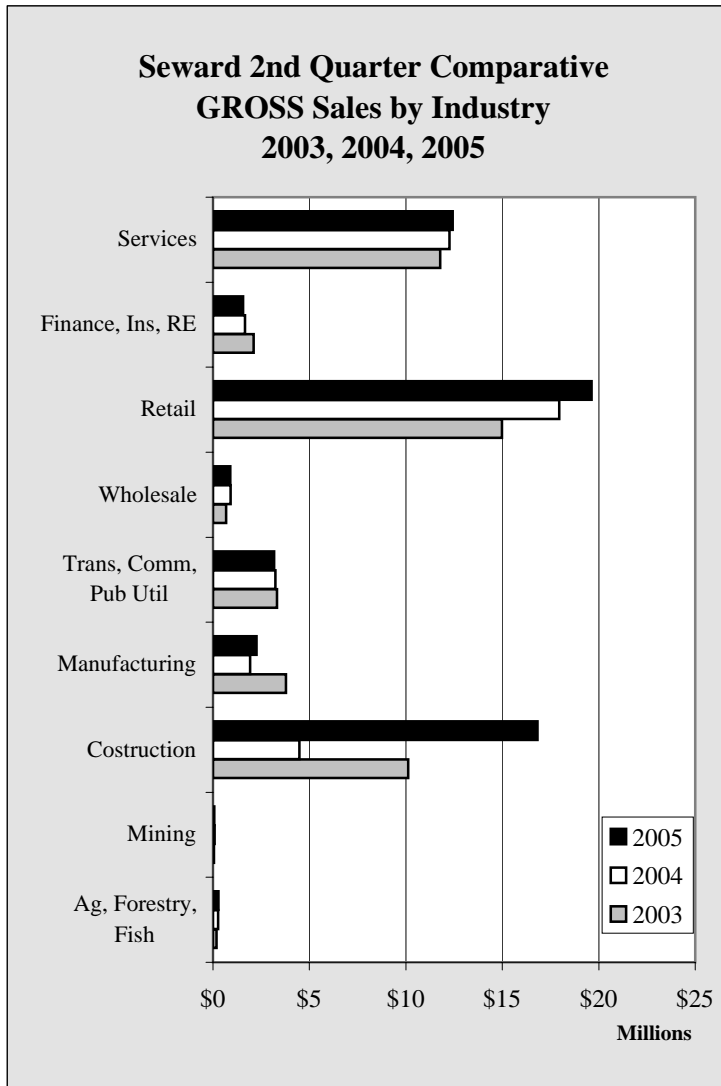

Chart 5.1

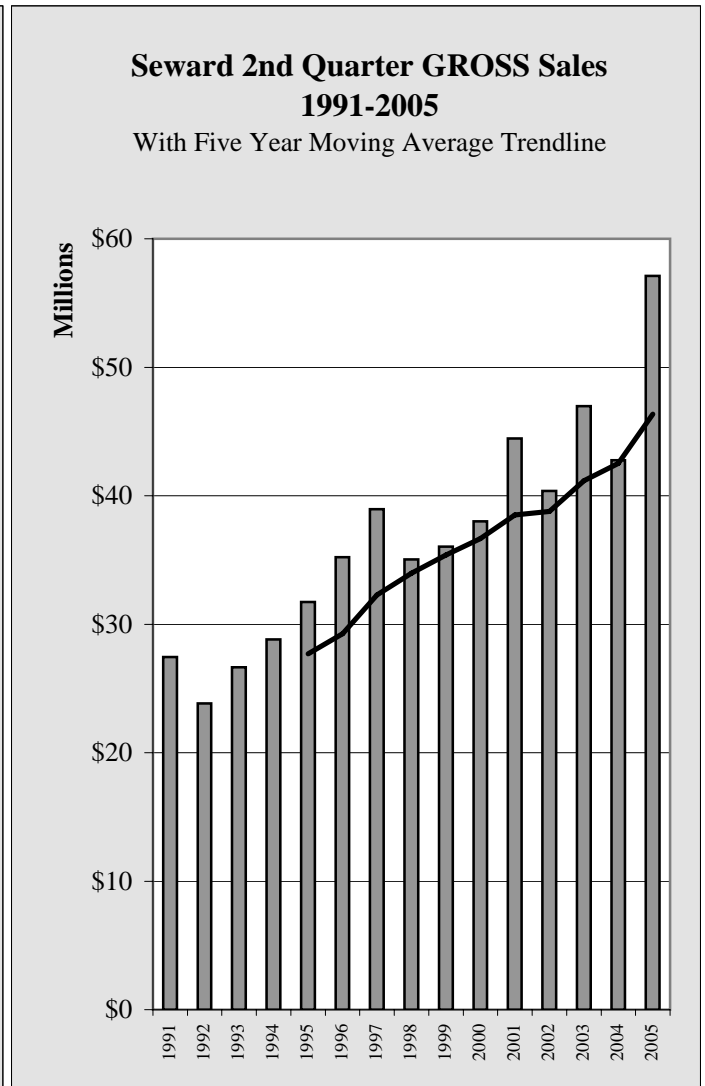

Chart 5.2

# Seward Sales

<b>Seward 2nd Quarter TAXABLE Sales by Industry - 1999-2005 - in \$</b>								
	1999	2000	2001	2002	2003	2004	2005	Annual Change
Ag, Forestry, Fish	65,022	79,544	69,770	57,747	70,505	77,870	87,792	12.7%
Mining	0	500	0	0	1,754	0	0	NA
Costruction	169,218	193,381	160,218	140,758	190,057	198,782	210,848	6.1%
Manufacturing	163,167	177,059	312,269	299,221	157,138	162,634	133,934	-17.6%
Trans, Comm, Pub Util	959,392	1,115,553	795,756	780,744	806,530	758,614	702,890	-7.3%
Wholesale	47,534	49,015	41,804	38,741	40,058	34,969	34,511	-1.3%
Retail	9,619,860	10,592,090	10,866,501	11,179,774	11,465,828	11,956,679	13,567,363	13.5%
Finance, Ins, RE	457,658	411,656	433,701	488,696	415,752	394,778	455,359	15.3%
Services	8,425,335	8,542,100	8,873,245	9,190,793	8,924,459	9,412,719	9,847,255	4.6%
<b>Total</b>	<b>19,907,186</b>	<b>21,160,898</b>	<b>21,553,264</b>	<b>22,176,474</b>	<b>22,072,081</b>	<b>22,997,045</b>	<b>25,039,952</b>	<b>8.9%</b>
Annual Change		6.3%	1.9%	2.9%	-0.5%	4.2%	8.9%	

Table 5.2

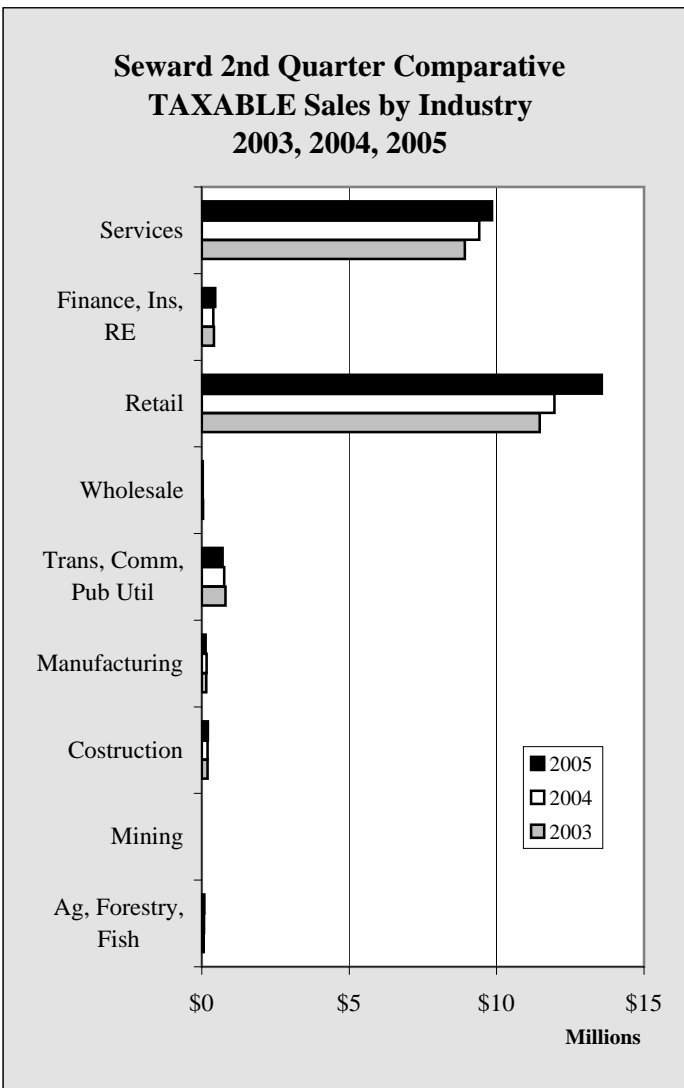

Chart 5.3

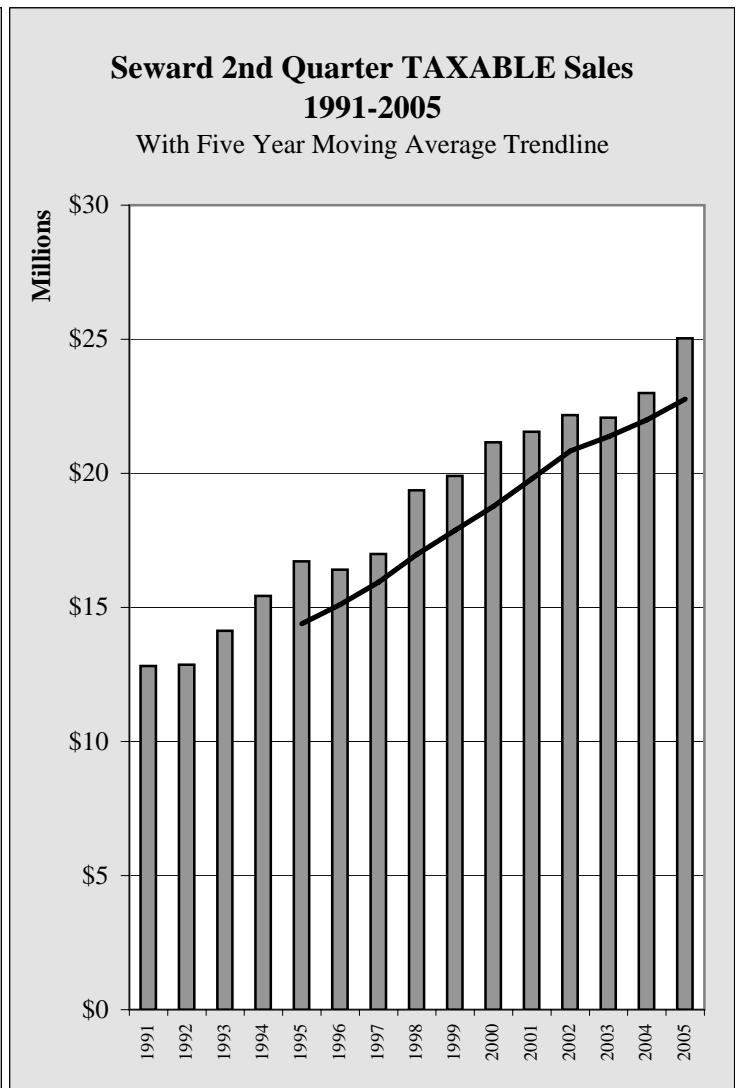

Chart 5.4

# Seward Sales

Seward YTD 6/30 GROSS Sales by Industry - 1999-2005 - in \$								
	1999	2000	2001	2002	2003	2004	2005	Annual Change
Ag, Forestry, Fish	254,017	315,170	198,348	174,118	216,267	325,576	318,941	-2.0%
Mining	172,680	246,904	169,292	180,102	117,510	103,785	100,192	-3.5%
Costruction	7,502,818	5,087,271	11,908,839	5,404,064	13,518,410	7,794,119	24,928,649	219.8%
Manufacturing	2,309,328	2,902,160	6,012,064	5,235,668	5,253,891	2,814,701	3,211,905	14.1%
Trans, Comm, Pub Util	5,264,445	6,073,951	5,846,878	5,658,092	5,398,582	5,825,755	5,913,400	1.5%
Wholesale	2,137,836	1,279,072	1,032,783	1,058,790	1,067,835	1,454,888	1,420,033	-2.4%
Retail	20,749,276	22,501,067	22,110,814	23,242,276	22,775,722	26,568,352	28,725,311	8.1%
Finance, Ins, RE	4,358,455	4,262,253	2,236,658	4,136,261	3,500,580	3,070,109	2,670,280	-13.0%
Services	16,649,357	14,433,986	15,467,874	18,250,018	16,070,540	15,978,804	16,288,151	1.9%
Total	59,398,212	57,101,834	64,983,550	63,339,389	67,919,337	63,936,089	83,576,862	30.7%
Annual Change		-3.9%	13.8%	-2.5%	7.2%	-5.9%	30.7%	

Table 5.3

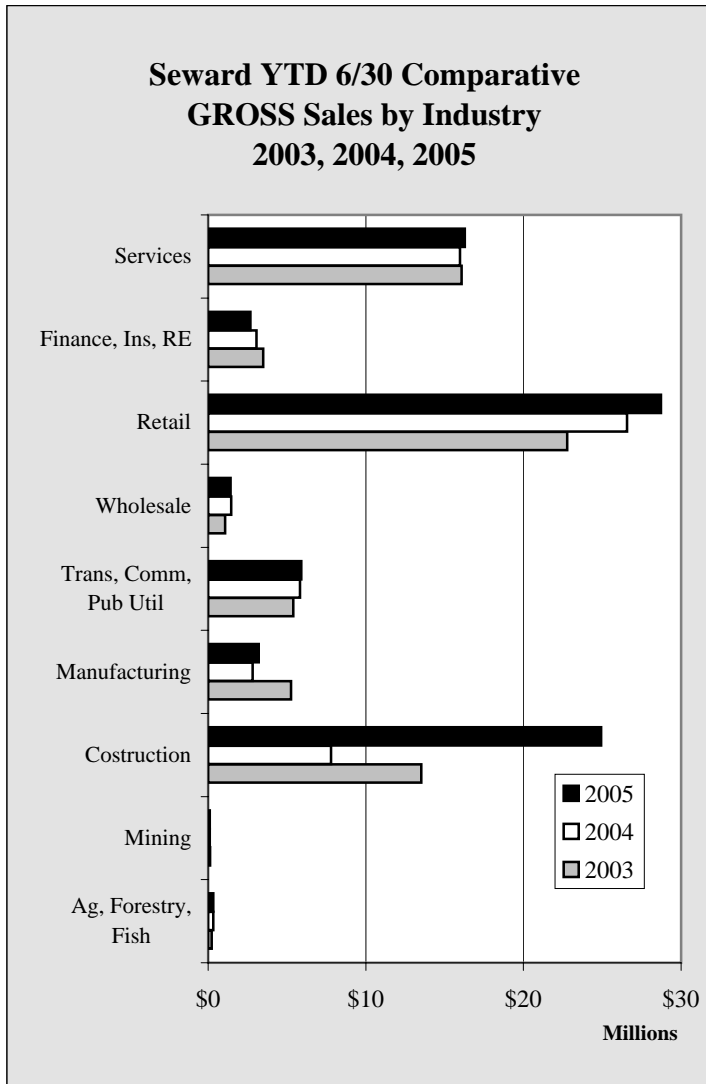

Chart 5.5

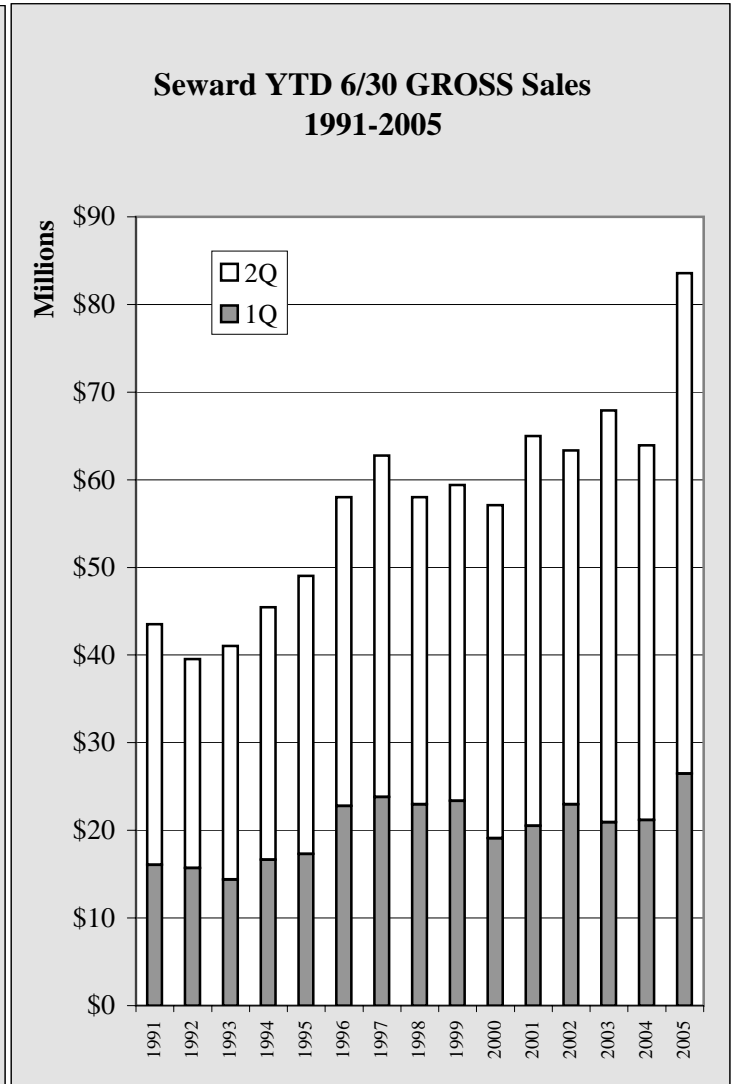

Chart 5.6

# Seward Sales

<b>Seward YTD 6/30 TAXABLE Sales by Industry - 1999-2005 - in \$</b>								
	1999	2000	2001	2002	2003	2004	2005	Annual Change
Ag, Forestry, Fish	71,444	91,048	73,760	64,476	82,178	89,793	96,281	7.2%
Mining	1,444	500	0	0	1,754	0	0	NA
Costruction	334,394	347,827	290,284	269,565	316,931	366,212	371,011	1.3%
Manufacturing	315,302	319,765	437,079	415,022	301,991	294,260	221,112	-24.9%
Trans, Comm, Pub Util	1,658,948	1,854,074	1,448,530	1,341,601	1,394,995	1,340,392	1,290,938	-3.7%
Wholesale	69,200	74,543	71,113	50,767	55,355	58,442	49,045	-16.1%
Retail	14,929,459	15,961,656	16,192,627	16,567,714	17,066,590	17,791,488	19,948,004	12.1%
Finance, Ins, RE	825,936	748,972	797,533	843,326	745,821	690,476	740,298	7.2%
Services	10,919,737	11,136,873	11,315,831	11,675,047	11,390,970	11,860,746	12,414,663	4.7%
Total	29,125,864	30,535,258	30,626,757	31,227,518	31,356,585	32,491,809	35,131,352	8.1%
Annual Change		4.8%	0.3%	2.0%	0.4%	3.6%	8.1%	

Table 5.4

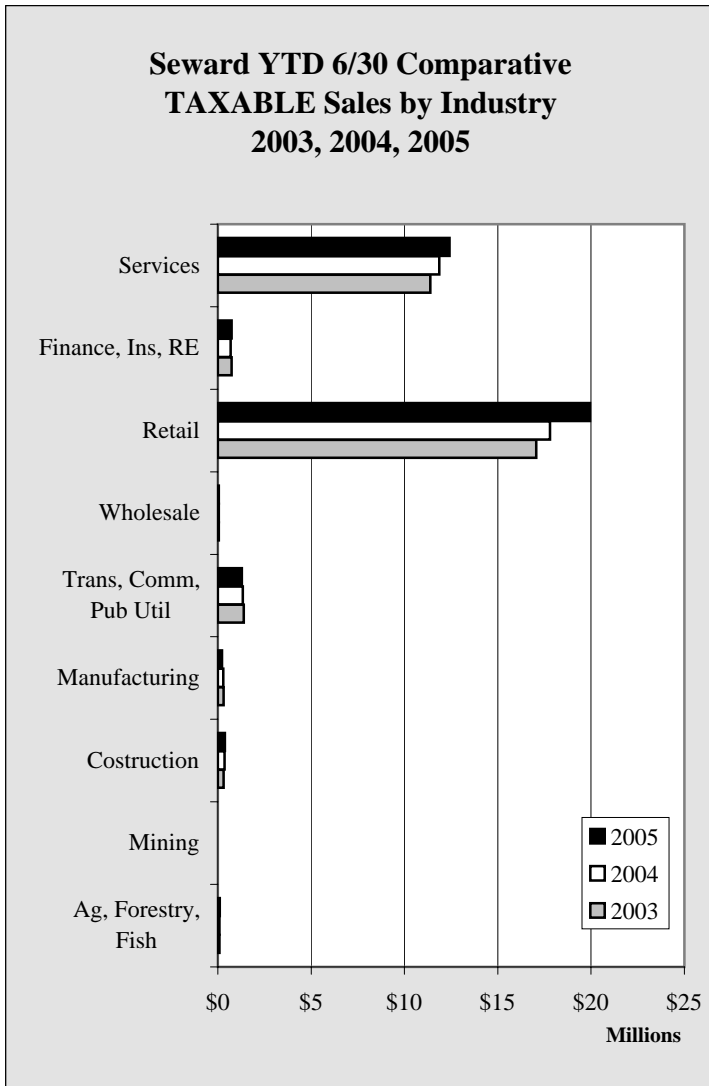

Chart 5.7

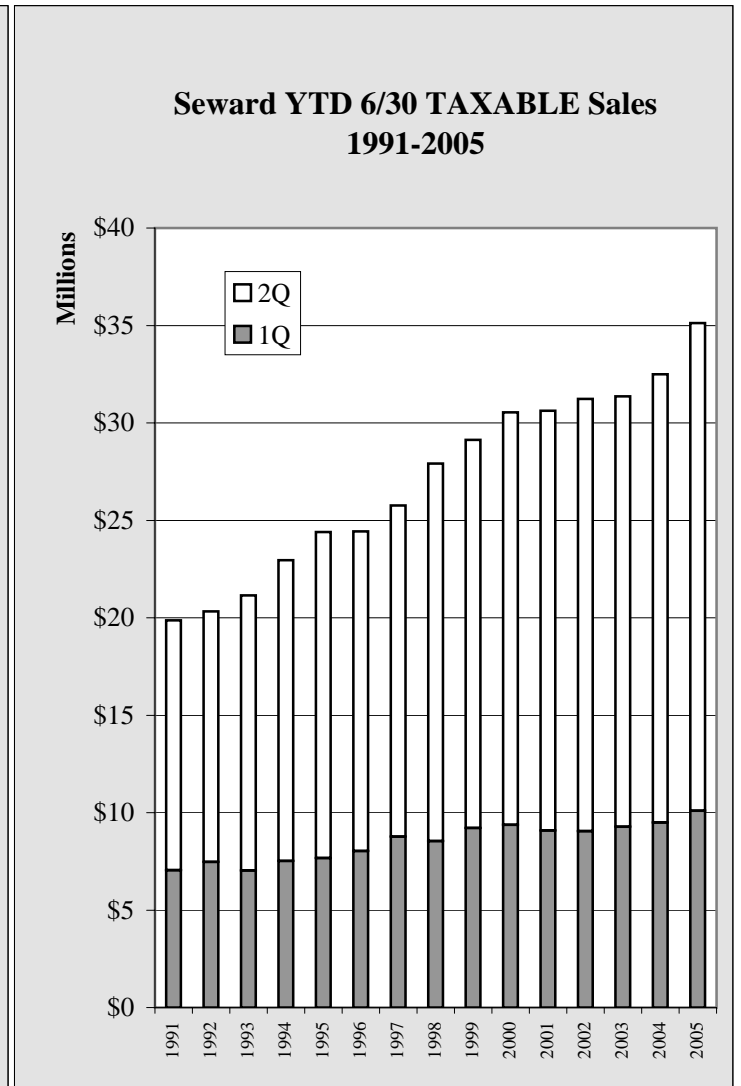

Chart 5.8

# Seward Sales

<b>Seward Annual GROSS Sales by Industry - 1998-2004 - in \$</b>								
	1998	1999	2000	2001	2002	2003	2004	Annual Change
Ag, Forestry, Fish	472,717	414,123	689,481	437,640	298,046	489,097	651,718	33.2%
Mining	229,681	332,546	405,115	330,859	377,441	189,755	228,403	20.4%
Costruction	19,183,104	12,588,992	16,255,816	21,082,426	11,084,304	28,881,212	31,492,128	9.0%
Manufacturing	4,266,551	4,895,971	9,541,307	12,023,577	11,540,635	10,446,881	7,214,583	-30.9%
Trans, Comm, Pub Util	13,656,791	12,011,182	14,705,875	12,840,952	13,026,323	12,969,855	11,702,893	-9.8%
Wholesale	7,270,151	3,064,525	2,339,175	2,231,731	2,208,659	2,600,579	3,953,585	52.0%
Retail	44,656,247	48,356,132	51,460,505	50,408,318	52,600,754	53,594,945	60,066,143	12.1%
Finance, Ins, RE	8,498,546	9,458,188	8,394,110	6,333,381	7,595,826	7,557,129	7,207,271	-4.6%
Services	34,272,460	39,033,862	38,360,895	42,671,669	43,635,138	40,232,069	43,696,493	8.6%
Total	132,506,248	130,155,521	142,152,279	148,360,553	142,367,126	156,961,522	166,213,217	5.9%
Annual Change		-1.8%	9.2%	4.4%	-4.0%	10.3%	5.9%	

Table 5.5

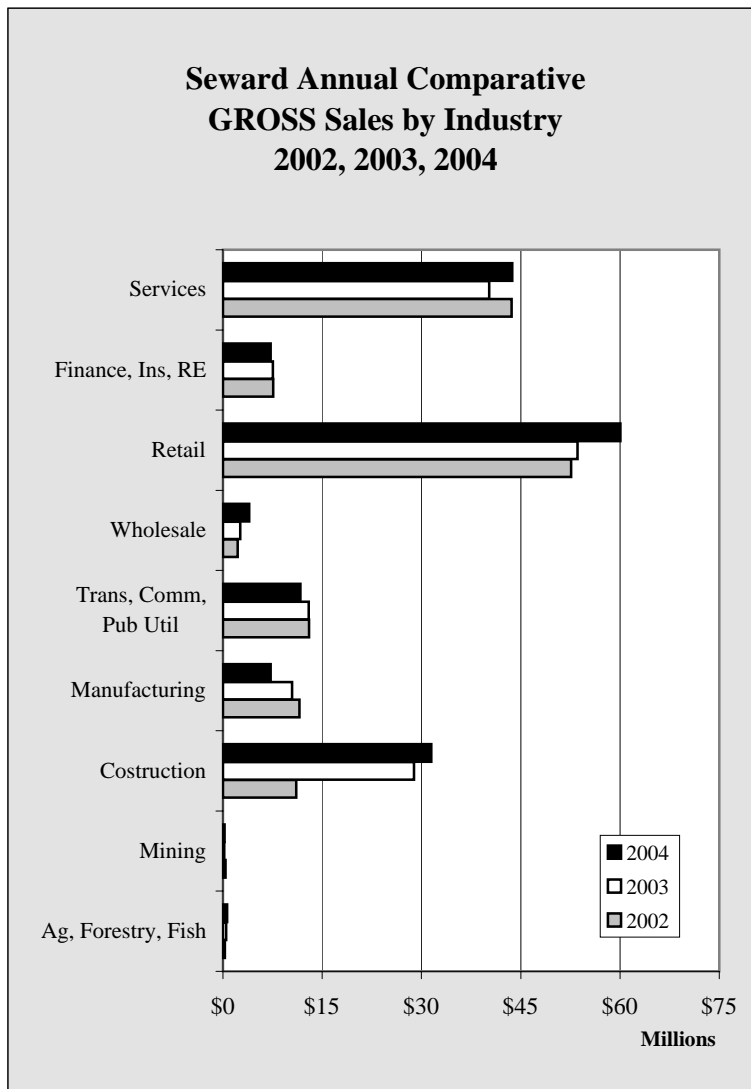

Chart 5.9

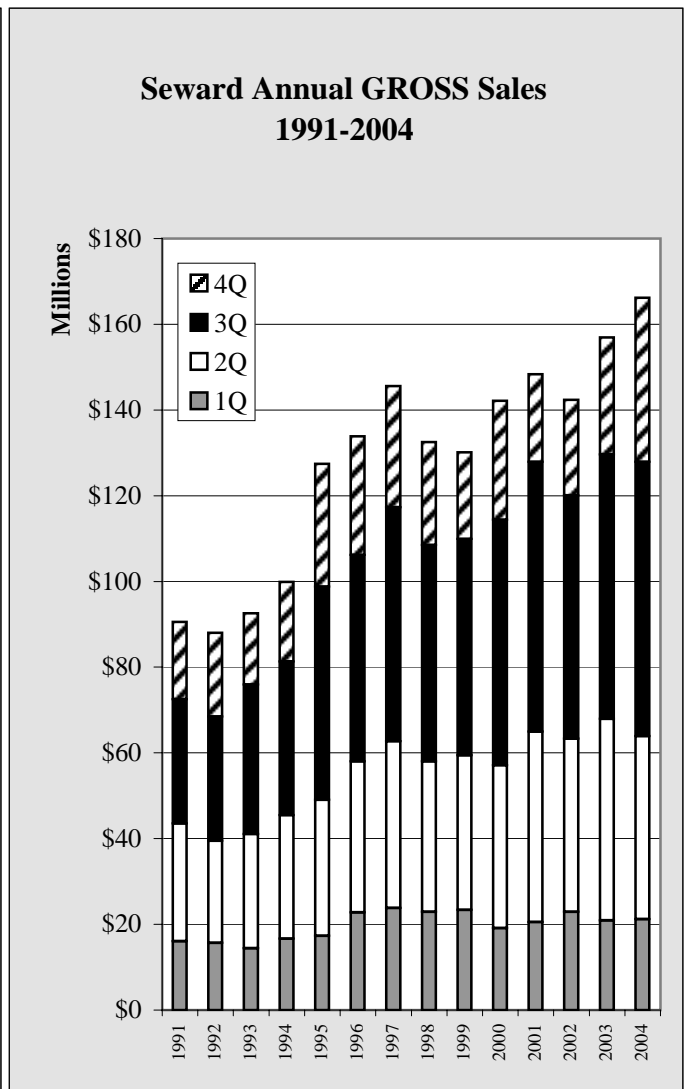

Chart 5.10

# Seward Sales

<b>Seward Annual TAXABLE Sales by Industry - 1998-2004 - in \$</b>								
	1998	1999	2000	2001	2002	2003	2004	Annual Change
Ag, Forestry, Fish	190,979	126,681	240,141	170,624	114,521	217,323	227,337	4.6%
Mining	221	1,444	500	0	0	3,455	0	NA
Costruction	709,318	718,945	671,326	567,626	565,290	683,590	739,180	8.1%
Manufacturing	505,430	585,005	639,366	962,382	988,659	629,648	605,028	-3.9%
Trans, Comm, Pub Util	3,826,559	3,801,591	3,991,338	2,936,725	2,916,215	2,921,669	2,853,456	-2.3%
Wholesale	382,361	128,287	141,551	135,396	107,027	119,020	107,918	-9.3%
Retail	33,478,522	35,539,902	37,600,377	38,191,615	39,040,960	40,272,089	42,433,354	5.4%
Finance, Ins, RE	1,604,043	1,662,085	1,583,364	1,665,703	1,780,596	1,593,083	1,583,071	-0.6%
Services	26,580,831	28,908,259	29,115,463	29,595,520	30,085,428	29,908,392	31,395,862	5.0%
<b>Total</b>	<b>67,278,264</b>	<b>71,472,199</b>	<b>73,983,426</b>	<b>74,225,591</b>	<b>75,598,696</b>	<b>76,348,269</b>	<b>79,945,206</b>	<b>4.7%</b>
Annual Change		6.2%	3.5%	0.3%	1.8%	1.0%	4.7%	

Table 5.6

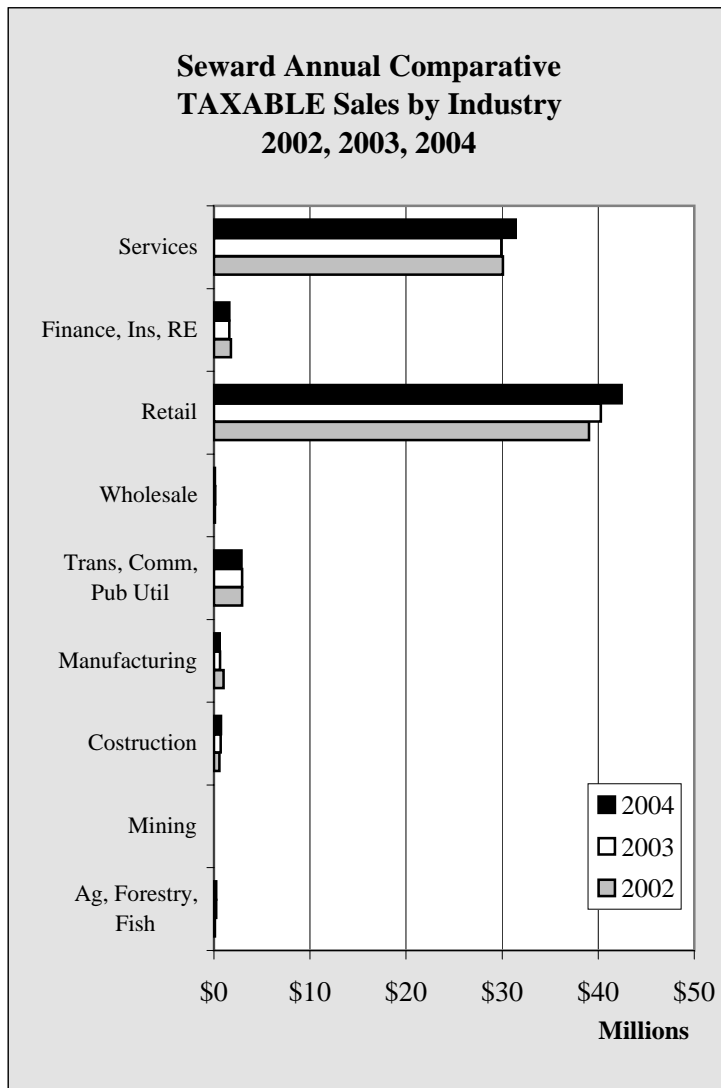

Chart 5.11

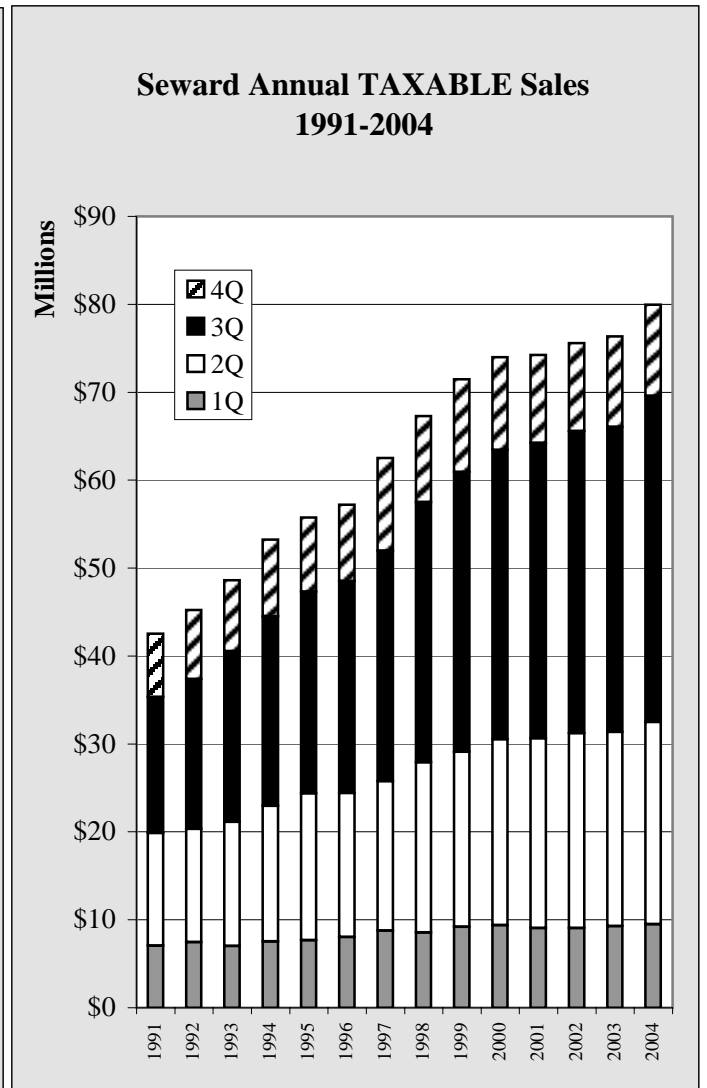

Chart 5.12

# Seward Sales

<b>Seward GROSS Sales by Industry by Quarter - 2002-2005 - in \$</b>					
	1st Quarter	2nd Quarter	3rd Quarter	4th Quarter	Total
<b>2002</b>					
Ag, Forestry, Fish	20,810	153,308	99,235	24,693	298,046
Mining	48,952	131,150	133,354	63,985	377,441
Costruction	3,040,364	2,363,700	2,223,341	3,456,899	11,084,304
Manufacturing	1,974,606	3,261,062	3,854,201	2,450,766	11,540,635
Trans, Comm, Pub Util	2,253,103	3,404,989	5,193,908	2,174,323	13,026,323
Wholesale	386,897	671,893	755,749	394,120	2,208,659
Retail	7,932,221	15,310,055	21,049,806	8,308,672	52,600,754
Finance, Ins, RE	1,790,625	2,345,636	2,473,329	986,236	7,595,826
Services	5,506,435	12,743,583	20,938,726	4,446,394	43,635,138
Government	0	0	0	0	0
<b>Total</b>	<b>22,954,013</b>	<b>40,385,376</b>	<b>56,721,649</b>	<b>22,306,088</b>	<b>142,367,126</b>
<b>2003</b>					
Ag, Forestry, Fish	35,450	180,817	233,386	39,444	489,097
Mining	67,921	49,589	49,094	23,151	189,755
Costruction	3,401,454	10,116,956	9,666,381	5,696,421	28,881,212
Manufacturing	1,468,277	3,785,614	2,466,178	2,726,812	10,446,881
Trans, Comm, Pub Util	2,084,901	3,313,681	5,201,510	2,369,763	12,969,855
Wholesale	385,079	682,756	888,555	644,189	2,600,579
Retail	7,798,633	14,977,089	21,297,449	9,521,774	53,594,945
Finance, Ins, RE	1,394,159	2,106,421	2,068,760	1,987,789	7,557,129
Services	4,299,310	11,771,230	19,836,458	4,325,071	40,232,069
Government	0	0	0	0	0
<b>Total</b>	<b>20,935,184</b>	<b>46,984,153</b>	<b>61,707,771</b>	<b>27,334,414</b>	<b>156,961,522</b>
<b>2004</b>					
Ag, Forestry, Fish	54,549	271,027	248,373	77,769	651,718
Mining	24,996	78,789	89,202	35,416	228,403
Costruction	3,306,762	4,487,357	6,884,443	16,813,566	31,492,128
Manufacturing	892,586	1,922,115	3,515,011	884,871	7,214,583
Trans, Comm, Pub Util	2,592,442	3,233,313	3,570,845	2,306,293	11,702,893
Wholesale	544,648	910,240	1,199,749	1,298,948	3,953,585
Retail	8,625,281	17,943,071	24,148,081	9,349,710	60,066,143
Finance, Ins, RE	1,407,043	1,663,066	2,516,118	1,621,044	7,207,271
Services	3,726,982	12,251,822	21,754,783	5,962,906	43,696,493
Government	0	0	0	0	0
<b>Total</b>	<b>21,175,289</b>	<b>42,760,800</b>	<b>63,926,605</b>	<b>38,350,523</b>	<b>166,213,217</b>
<b>2005</b>					
				<b>Year to Date</b>	
Ag, Forestry, Fish	30,789	288,152			318,941
Mining	32,647	67,545			100,192
Costruction	8,105,477	16,823,172			24,928,649
Manufacturing	954,605	2,257,300			3,211,905
Trans, Comm, Pub Util	2,745,656	3,167,744			5,913,400
Wholesale	520,743	899,290			1,420,033
Retail	9,100,347	19,624,964			28,725,311
Finance, Ins, RE	1,102,999	1,567,281			2,670,280
Services	3,866,022	12,422,129			16,288,151
Government	0	0			0
<b>Total</b>	<b>26,459,285</b>	<b>57,117,577</b>			<b>83,576,862</b>

Table 5.7



# Seward Sales

<b>Seward TAXABLE Sales by Industry by Quarter - 2002-2005 - in \$</b>					
	1st Quarter	2nd Quarter	3rd Quarter	4th Quarter	Total
<b>2002</b>					
Ag, Forestry, Fish	6,729	57,747	39,602	10,443	114,521
Mining	0	0	0	0	0
Costruction	128,807	140,758	155,433	140,292	565,290
Manufacturing	115,801	299,221	451,494	122,143	988,659
Trans, Comm, Pub Util	560,857	780,744	991,036	583,578	2,916,215
Wholesale	12,026	38,741	39,460	16,800	107,027
Retail	5,387,940	11,179,774	16,466,497	6,006,749	39,040,960
Finance, Ins, RE	354,630	488,696	593,326	343,944	1,780,596
Services	2,484,254	9,190,793	15,601,212	2,809,169	30,085,428
Government	0	0	0	0	0
<b>Total</b>	<b>9,051,044</b>	<b>22,176,474</b>	<b>34,338,060</b>	<b>10,033,118</b>	<b>75,598,696</b>
<b>2003</b>					
Ag, Forestry, Fish	11,673	70,505	116,949	18,196	217,323
Mining	0	1,754	1,701	0	3,455
Costruction	126,874	190,057	174,588	192,071	683,590
Manufacturing	144,853	157,138	183,847	143,810	629,648
Trans, Comm, Pub Util	588,465	806,530	941,349	585,325	2,921,669
Wholesale	15,297	40,058	49,420	14,245	119,020
Retail	5,600,762	11,465,828	16,898,663	6,306,836	40,272,089
Finance, Ins, RE	330,069	415,752	530,822	316,440	1,593,083
Services	2,466,511	8,924,459	15,805,043	2,712,379	29,908,392
Government	0	0	0	0	0
<b>Total</b>	<b>9,284,504</b>	<b>22,072,081</b>	<b>34,702,382</b>	<b>10,289,302</b>	<b>76,348,269</b>
<b>2004</b>					
Ag, Forestry, Fish	11,923	77,870	129,744	7,800	227,337
Mining	0	0	0	0	0
Costruction	167,430	198,782	187,781	185,187	739,180
Manufacturing	131,626	162,634	163,756	147,012	605,028
Trans, Comm, Pub Util	581,778	758,614	1,009,472	503,592	2,853,456
Wholesale	23,473	34,969	34,753	14,723	107,918
Retail	5,834,809	11,956,679	18,197,996	6,443,870	42,433,354
Finance, Ins, RE	295,698	394,778	563,136	329,459	1,583,071
Services	2,448,027	9,412,719	16,790,786	2,744,330	31,395,862
Government	0	0	0	0	0
<b>Total</b>	<b>9,494,764</b>	<b>22,997,045</b>	<b>37,077,424</b>	<b>10,375,973</b>	<b>79,945,206</b>
<b>2005</b>					
				<b>Year to Date</b>	
Ag, Forestry, Fish	8,489	87,792			96,281
Mining	0	0			0
Costruction	160,163	210,848			371,011
Manufacturing	87,178	133,934			221,112
Trans, Comm, Pub Util	588,048	702,890			1,290,938
Wholesale	14,534	34,511			49,045
Retail	6,380,641	13,567,363			19,948,004
Finance, Ins, RE	284,939	455,359			740,298
Services	2,567,408	9,847,255			12,414,663
Government	0	0			0
<b>Total</b>	<b>10,091,400</b>	<b>25,039,952</b>			<b>35,131,352</b>

Table 5.8

# Seward Construction

<b>Seward 2nd Quarter Permit VALUES by Type - 1999-2005 - in \$</b>								
	1999	2000	2001	2002	2003	2004	2005	Annual Change
Residential - New	585,000	530,000	0	400,000	215,000	873,000	388,000	-55.6%
Residential - Add/Alter	164,500	67,600	73,000	169,157	100,000	144,900	105,520	-27.2%
Commercial - New	250,000	210,000	155,000	3,294,730	3,313,000	5,000,000	71,020	-98.6%
Commercial - Add/Alter	82,614	957,800	438,239	25,000	44,010	1,426,000	105,000	-92.6%
<b>TOTAL</b>	<b>1,082,114</b>	<b>1,765,400</b>	<b>666,239</b>	<b>3,888,887</b>	<b>3,672,010</b>	<b>7,443,900</b>	<b>669,540</b>	<b>-91.0%</b>
Annual Change		63.1%	-62.3%	483.7%	-5.6%	102.7%	-91.0%	

Table 5.9

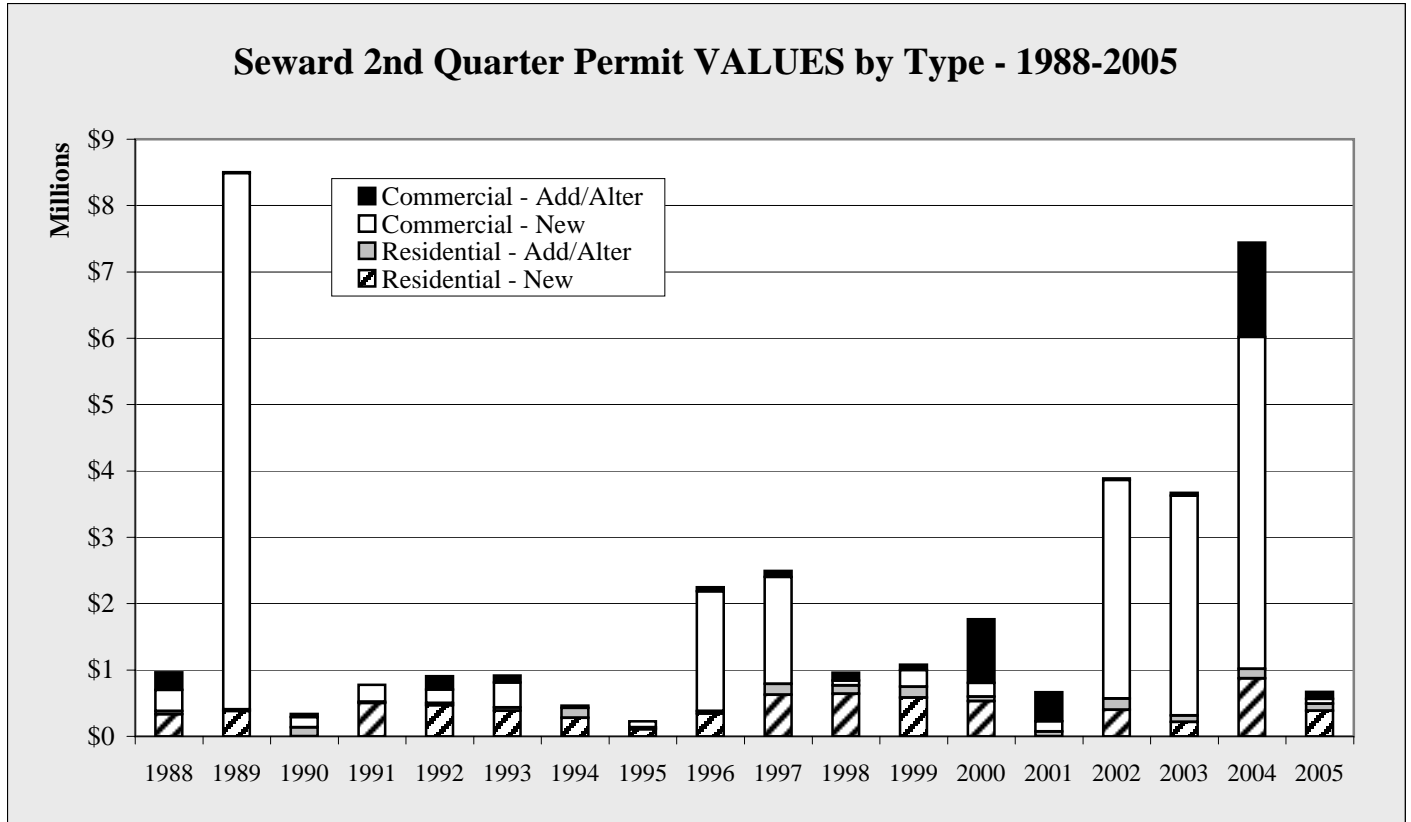

Chart 5.13

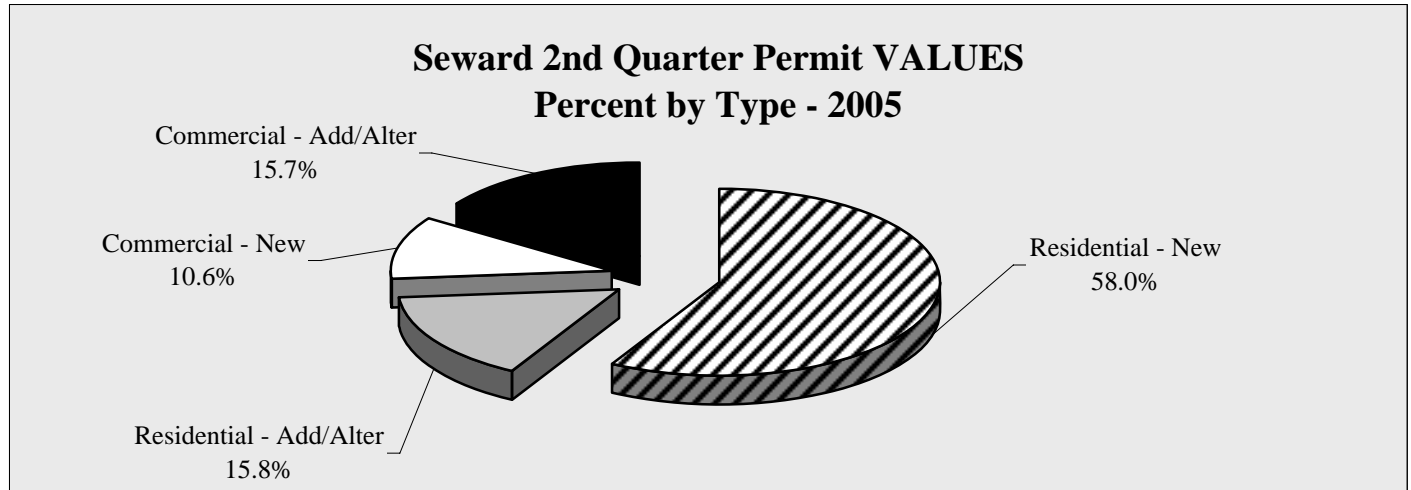

Chart 5.14

# Seward Construction

Seward 2nd Quarter Permit VOLUME by Type - 1999-2005								
	1999	2000	2001	2002	2003	2004	2005	Annual Change
Residential - New	5	2	0	1	2	4	3	-25.0%
Residential - Add/Alter	7	8	3	15	3	7	15	114.3%
Commercial - New	1	3	3	4	4	1	2	100.0%
Commercial - Add/Alter	5	7	8	9	4	9	1	-88.9%
<b>TOTAL</b>	<b>18</b>	<b>20</b>	<b>14</b>	<b>29</b>	<b>13</b>	<b>21</b>	<b>21</b>	<b>0.0%</b>
<b>Annual Change</b>		11.1%	-30.0%	107.1%	-55.2%	61.5%	0.0%	

Table 5.10

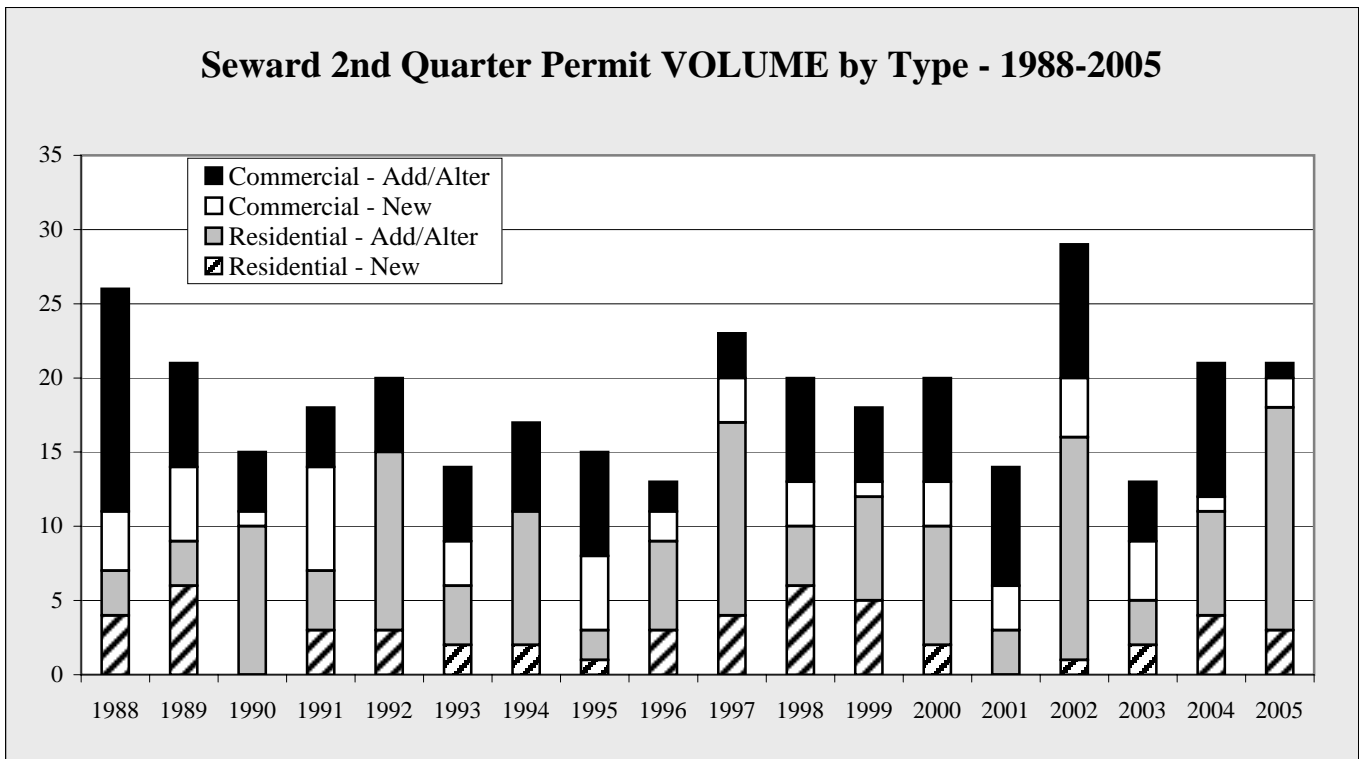

Chart 5.15

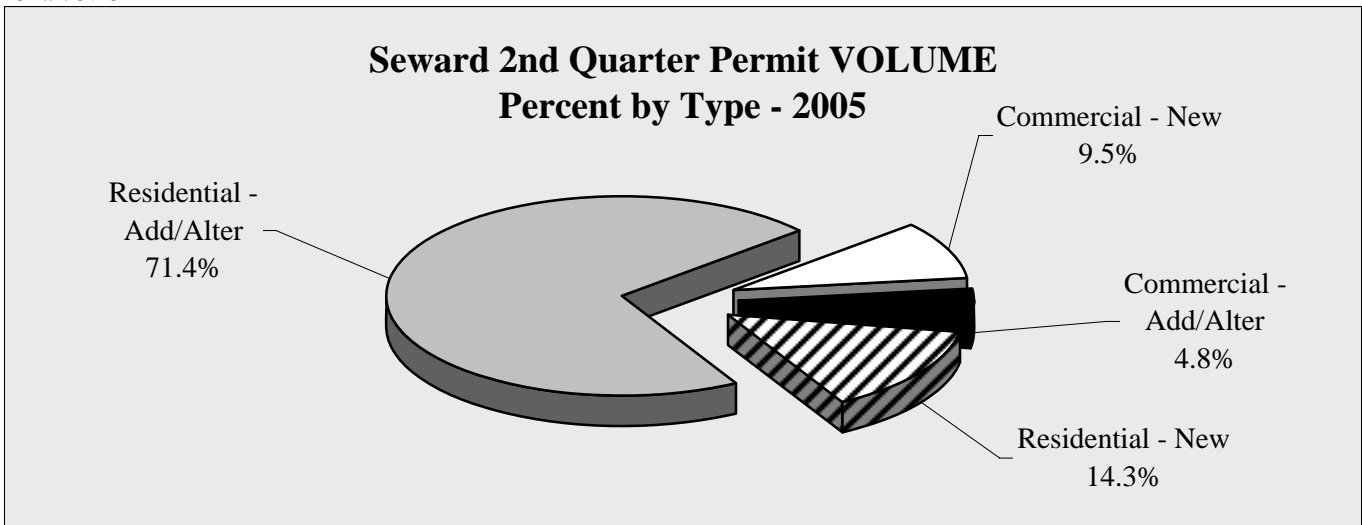

Chart 5.16

# Seward Construction

Seward YTD 6/30 Permit VALUES by Type - 1999-2005 - in \$								
	1999	2000	2001	2002	2003	2004	2005	Annual Change
Residential - New	585,000	760,000	0	520,000	333,000	873,000	1,443,000	65.3%
Residential - Add/Alter	169,700	67,600	103,200	194,653	157,500	192,900	111,820	-42.0%
Commercial - New	250,000	295,000	155,000	3,294,730	3,385,000	12,500,000	277,020	-97.8%
Commercial - Add/Alter	1,117,964	998,100	824,739	360,944	1,701,865	1,619,600	345,000	-78.7%
<b>TOTAL</b>	<b>2,122,664</b>	<b>2,120,700</b>	<b>1,082,939</b>	<b>4,370,327</b>	<b>5,577,365</b>	<b>15,185,500</b>	<b>2,176,840</b>	<b>-85.7%</b>
Annual Change		-0.1%	-48.9%	303.6%	27.6%	172.3%	-85.7%	

Table 5.11

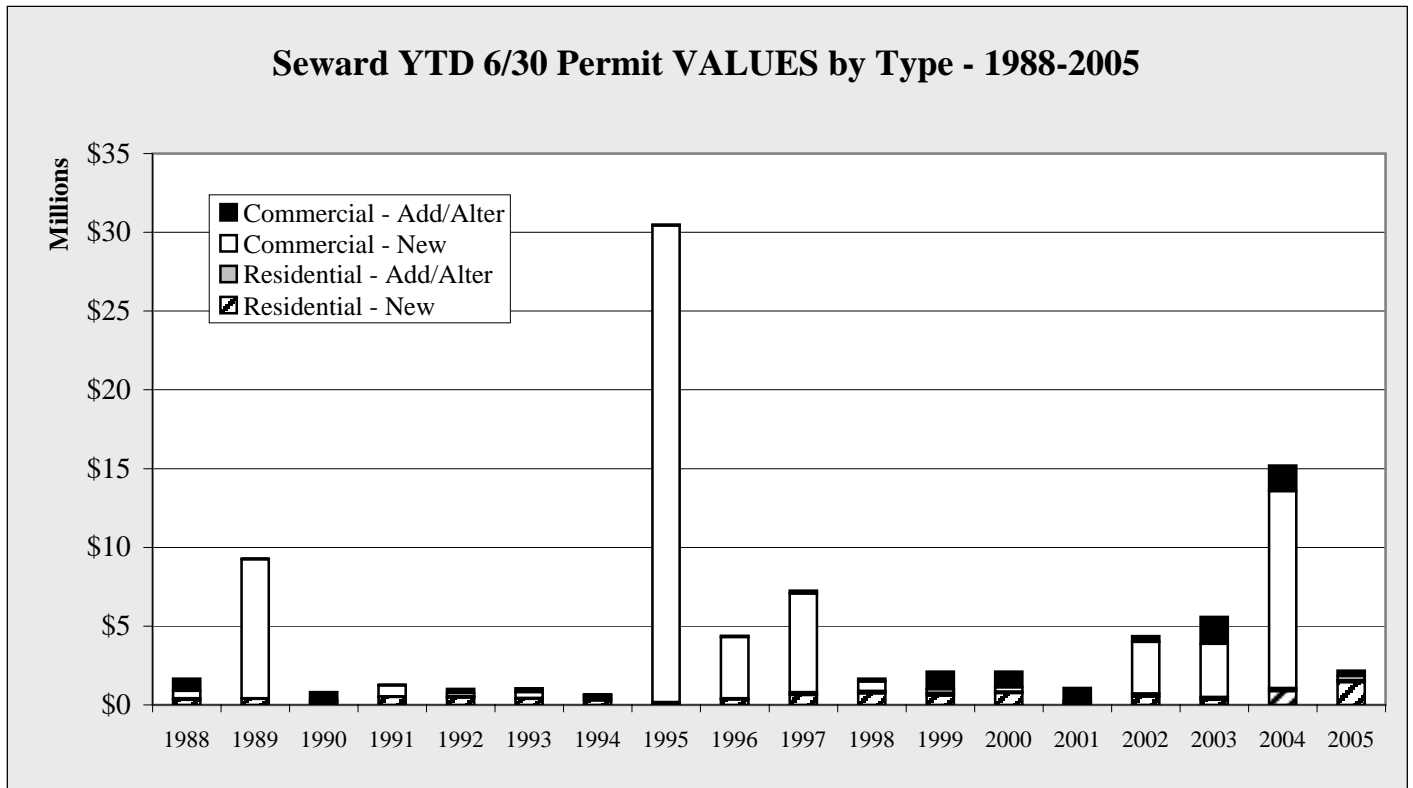

Chart 5.17

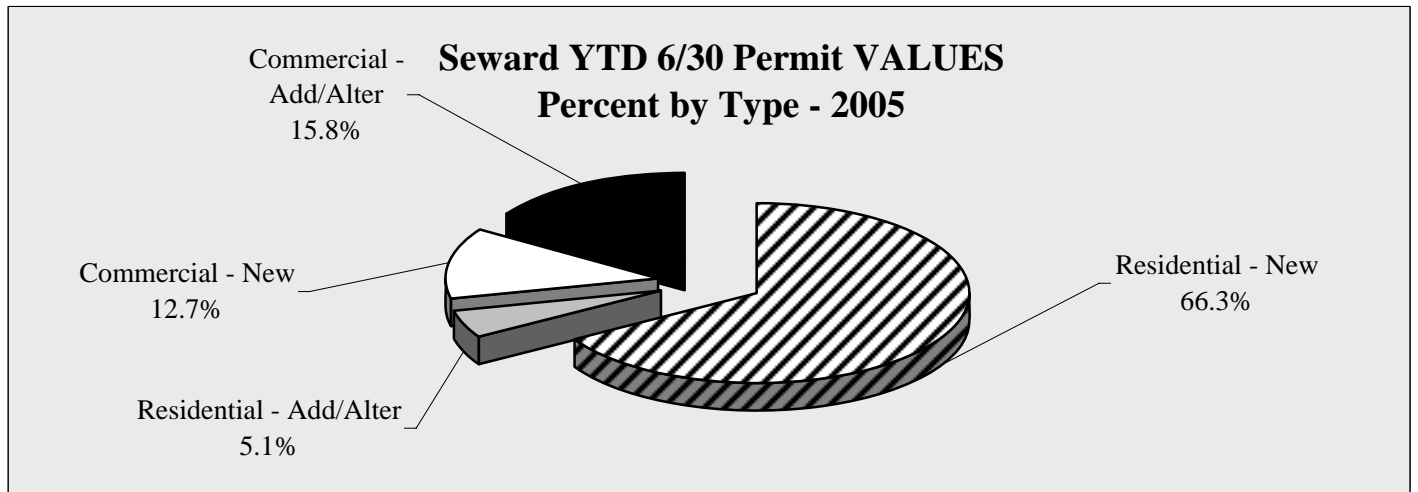

Chart 5.18

# Seward Construction

**Seward YTD 6/30 Permit VOLUME by Type - 1999-2005**

	1999	2000	2001	2002	2003	2004	2005	Annual Change
Residential - New	5	3	0	2	3	4	7	75.0%
Residential - Add/Alter	8	8	7	18	5	9	18	100.0%
Commercial - New	1	4	3	4	5	2	4	100.0%
Commercial - Add/Alter	9	10	15	15	11	13	5	-61.5%
<b>TOTAL</b>	<b>23</b>	<b>25</b>	<b>25</b>	<b>39</b>	<b>24</b>	<b>28</b>	<b>34</b>	<b>21.4%</b>
Annual Change		8.7%	0.0%	56.0%	-38.5%	16.7%	21.4%	

Table 5.12

**Seward YTD 6/30 Permit VOLUME by Type - 1988-2005**

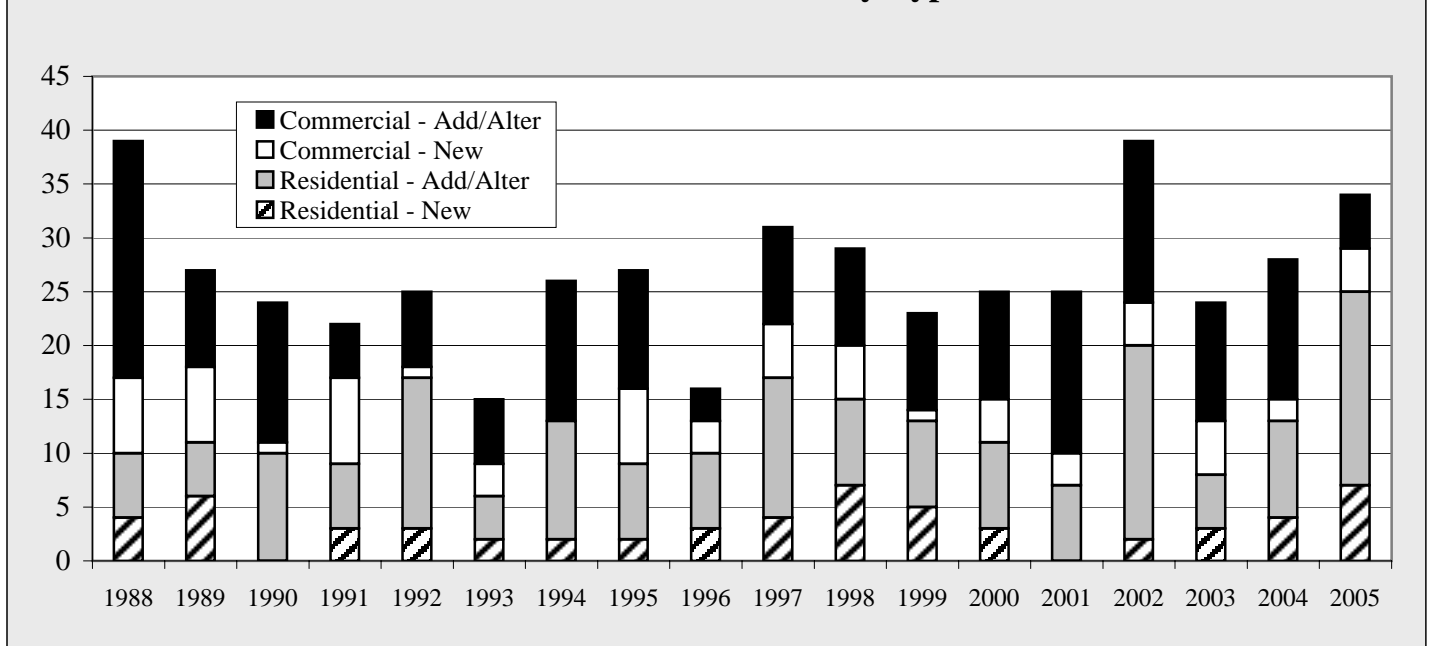

Chart 5.19

**Seward YTD 6/30 Permit VOLUME  
Percent by Type - 2005**

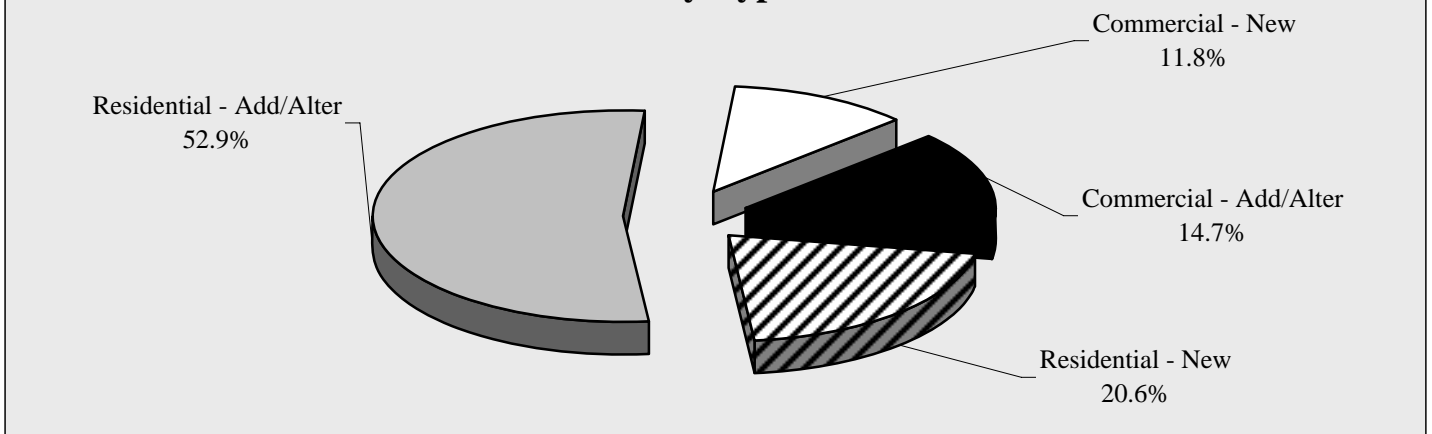

Chart 5.20

# Seward Construction

<b>Seward Annual Permit VALUES by Type by Quarter - 1998-2005 - in \$</b>					
	1st Quarter	2nd Quarter	3rd Quarter	4th Quarter	Total
<b>1998</b>					
Residential - New	85,000	643,000	417,000	0	1,145,000
Residential - Add/Alter	25,043	122,000	59,000	34,500	240,543
Commercial - New	536,232	75,000	4,054,000	260,000	4,925,232
Commercial - Add/Alter	56,800	119,000	256,186	5,100	437,086
<b>TOTAL</b>	<b>703,075</b>	<b>959,000</b>	<b>4,786,186</b>	<b>299,600</b>	<b>6,747,861</b>
<b>1999</b>					
Residential - New	0	585,000	509,400	123,000	1,217,400
Residential - Add/Alter	5,200	164,500	71,900	15,000	256,600
Commercial - New	0	250,000	903,275	240,000	1,393,275
Commercial - Add/Alter	1,035,350	82,614	131,174	125,000	1,374,138
<b>TOTAL</b>	<b>1,040,550</b>	<b>1,082,114</b>	<b>1,615,749</b>	<b>503,000</b>	<b>4,241,413</b>
<b>2000</b>					
Residential - New	230,000	530,000	263,000	0	1,023,000
Residential - Add/Alter	0	67,600	39,000	339,400	446,000
Commercial - New	85,000	210,000	330,000	200,000	825,000
Commercial - Add/Alter	40,300	957,800	79,465	80,000	1,157,565
<b>TOTAL</b>	<b>355,300</b>	<b>1,765,400</b>	<b>711,465</b>	<b>619,400</b>	<b>3,451,565</b>
<b>2001</b>					
Residential - New	0	0	150,000	300,000	450,000
Residential - Add/Alter	30,200	73,000	136,014	105,000	344,214
Commercial - New	0	155,000	331,028	0	486,028
Commercial - Add/Alter	386,500	438,239	25,000	587,000	1,436,739
<b>TOTAL</b>	<b>416,700</b>	<b>666,239</b>	<b>642,042</b>	<b>992,000</b>	<b>2,716,981</b>
<b>2002</b>					
Residential - New	120,000	400,000	205,000	0	725,000
Residential - Add/Alter	25,496	169,157	27,555	19,800	242,008
Commercial - New	0	3,294,730	750,000	2,100,000	6,144,730
Commercial - Add/Alter	335,944	25,000	325,021	113,000	798,965
<b>TOTAL</b>	<b>481,440</b>	<b>3,888,887</b>	<b>1,307,576</b>	<b>2,232,800</b>	<b>7,910,703</b>
<b>2003</b>					
Residential - New	118,000	215,000	744,500	0	1,077,500
Residential - Add/Alter	57,500	100,000	87,000	50,000	294,500
Commercial - New	72,000	3,313,000	900,000	5,000	4,290,000
Commercial - Add/Alter	1,657,855	44,010	101,400	517,500	2,320,765
<b>TOTAL</b>	<b>1,905,355</b>	<b>3,672,010</b>	<b>1,832,900</b>	<b>572,500</b>	<b>7,982,765</b>
<b>2004</b>					
Residential - New	0	873,000	1,257,000	0	2,130,000
Residential - Add/Alter	48,000	144,900	299,500	8,000	500,400
Commercial - New	7,500,000	5,000,000	518,800	0	13,018,800
Commercial - Add/Alter	193,600	1,426,000	191,000	251,350	2,061,950
<b>TOTAL</b>	<b>7,741,600</b>	<b>7,443,900</b>	<b>2,266,300</b>	<b>259,350</b>	<b>17,711,150</b>
<b>2005</b>					
					<b>Year to Date</b>
Residential - New	1,055,000	388,000			1,443,000
Residential - Add/Alter	6,300	105,520			111,820
Commercial - New	206,000	71,020			277,020
Commercial - Add/Alter	240,000	105,000			345,000
<b>TOTAL</b>	<b>1,507,300</b>	<b>669,540</b>			<b>2,176,840</b>

Table 5.13

# Seward Construction

<b>Seward Annual Permit VOLUME by Type by Quarter - 1998-2005</b>					
	1st Quarter	2nd Quarter	3rd Quarter	4th Quarter	Total
<b>1998</b>					
Residential - New	1	6	2	0	9
Residential - Add/Alter	4	4	5	5	18
Commercial - New	2	3	4	1	10
Commercial - Add/Alter	2	7	2	1	12
<b>TOTAL</b>	<b>9</b>	<b>20</b>	<b>13</b>	<b>7</b>	<b>49</b>
<b>1999</b>					
Residential - New	0	5	4	1	10
Residential - Add/Alter	1	7	5	2	15
Commercial - New	0	1	5	1	7
Commercial - Add/Alter	4	5	9	6	24
<b>TOTAL</b>	<b>5</b>	<b>18</b>	<b>23</b>	<b>10</b>	<b>56</b>
<b>2000</b>					
Residential - New	1	2	2	0	5
Residential - Add/Alter	0	8	7	4	19
Commercial - New	1	3	3	1	8
Commercial - Add/Alter	3	7	5	4	19
<b>TOTAL</b>	<b>5</b>	<b>20</b>	<b>17</b>	<b>9</b>	<b>51</b>
<b>2001</b>					
Residential - New	0	0	1	2	3
Residential Add/Alter	4	3	9	2	18
Commercial - New	0	3	3	0	6
Commercial - Add/Alter	7	8	1	5	21
<b>TOTAL</b>	<b>11</b>	<b>14</b>	<b>14</b>	<b>9</b>	<b>48</b>
<b>2002</b>					
Residential - New	1	1	2	0	4
Residential Add/Alter	3	15	3	4	25
Commercial - New	0	4	1	3	8
Commercial - Add/Alter	6	9	8	4	27
<b>TOTAL</b>	<b>10</b>	<b>29</b>	<b>14</b>	<b>11</b>	<b>64</b>
<b>2003</b>					
Residential - New	1	2	5	0	8
Residential Add/Alter	2	3	5	1	11
Commercial - New	1	4	1	1	7
Commercial - Add/Alter	7	4	4	9	24
<b>TOTAL</b>	<b>11</b>	<b>13</b>	<b>15</b>	<b>11</b>	<b>50</b>
<b>2004</b>					
Residential - New	0	4	8	0	12
Residential Add/Alter	2	7	5	1	15
Commercial - New	1	1	2	0	4
Commercial - Add/Alter	4	9	4	6	23
<b>TOTAL</b>	<b>7</b>	<b>21</b>	<b>19</b>	<b>7</b>	<b>54</b>
<b>2005</b>					
	<b>Year to Date</b>				
Residential - New	4	3			7
Residential Add/Alter	3	15			18
Commercial - New	2	2			4
Commercial - Add/Alter	4	1			5
<b>TOTAL</b>	<b>13</b>	<b>21</b>	<b>0</b>	<b>0</b>	<b>34</b>

Table 5.14

# Seward Cost of Food

Cost of food data is collected by the University of Alaska, Fairbanks Cooperative Extension. Each quarter the Cooperative Extension surveys up to three grocers in communities throughout the state to determine the cost of food for one week. Specific guidelines are presented to the surveyors regarding item size and sale price for 104 items.

<b>SEWARD</b>								
	June 1999	June 2000	June 2001	June 2002	June 2003	June 2004	June 2005	Annual Change
Sales Tax Rate	5.0	5.0	5.0	5.0	5.0	6.0	6.0	
Percent of Food Unavailable	0.0	1.0	3.0	0.0	2.0	1.0	0.0	
Child, 1 year	18.40	18.56	19.32	18.93	18.60	22.70	21.4	-1.7%
Child, 2 years	0.00	0.00	0.00	18.93	18.51	22.26	21.2	-2.2%
Children 3-5 years of age	20.14	20.40	19.32	20.83	21.39	24.45	23.4	2.7%
Children 6-8 years of age	26.82	27.17	28.17	27.70	28.70	32.68	31.5	3.6%
Children 9-11 years of age	30.40	30.74	31.92	31.37	33.47	36.82	35.4	6.7%
Males 12-14 years of age	34.28	34.81	36.14	35.52	36.59	41.71	40.1	3.0%
Males 15-19 years of age	35.25	35.97	37.29	36.65	38.03	42.82	41.3	3.8%
Males 20-50 years of age	34.95	35.68	37.00	36.46	37.96	42.59	41.3	4.1%
Males 51 and older	33.31	34.03	35.18	34.56	35.73	40.54	39.3	3.4%
Females 12-19 years of age	29.53	29.97	31.15	30.61	30.90	35.94	34.6	0.9%
Females 20-50 years of age	30.50	31.23	32.30	31.74	32.40	37.10	36.0	2.1%
Females 51 and older	29.63	30.36	31.52	30.89	32.11	36.10	35.0	3.9%
Family of 2, 20-50 years of age	72.04	73.57	76.23	75.02	77.40	87.67	85.0	3.2%
Family of 2, 51 years and older	69.23	70.87	73.39	72.00	74.63	84.30	81.7	3.7%
Family of 4, children 1-5 years	103.99	105.87	109.77	107.96	110.28	126.40	121.8	2.1%
Family of 4, children 6-11 years	122.68	124.82	129.40	127.26	132.52	149.20	144.1	4.1%
Electricity, 1000 kWh	132.28	122.01	133.07	133.59	130.79	135.64	139.5	-2.1%
Heating Oil, 55 gal	75.17	74.80	79.20	67.10	83.33	107.80	135.3	24.2%
Gasoline, auto, 55 gal	82.45	96.25	101.20	92.95	98.45	118.25	126.5	5.9%
Lumber, 2X4X8	3.84	2.92	2.78	3.06	2.72	3.77	3.9	-11.1%
Propane, 100 lb. Refill		41.30	41.29	45.00	55.70	61.36	68.9	23.8%

Table 5.16



# Seward Cost of Food

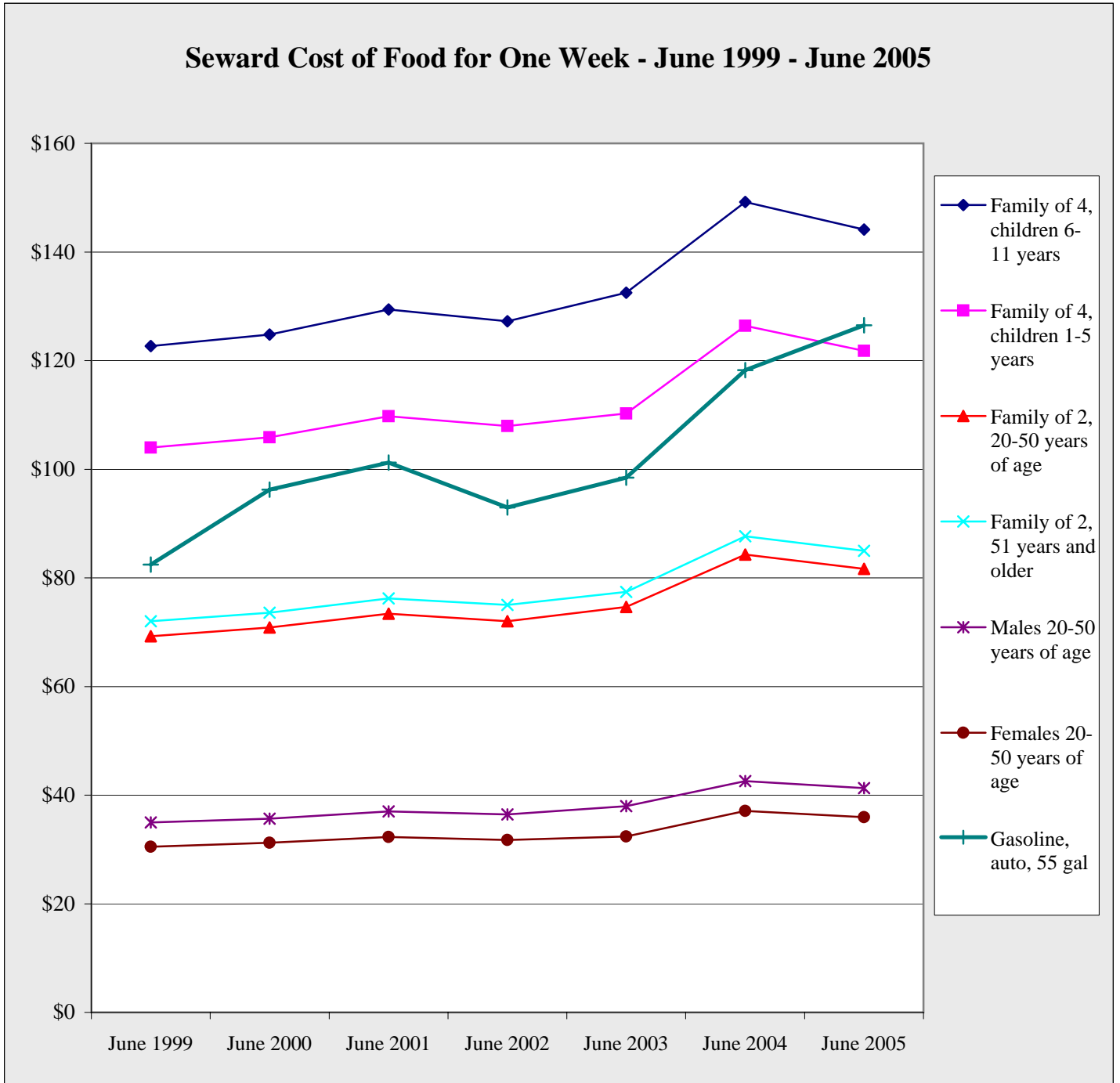

Chart 5.21

# Seward Population

## Seward Select Census Detail - 1990 v 2000

<b>Population</b>					<b>Housing</b>					
	1990	2000	Percent Change	Percent of Total		1990	2000	Percent Change	Percent of Total	
Total Population	2,699	2,830	4.9%	100.0%	<b>Total Households</b>	886	917	3.5%	100.0%	
Male	1,587	1,699	7.1%	60.0%	Family Households	536	556	3.7%	60.6%	
Female	1,112	1,131	1.7%	40.0%	With Children Under 18	NA	327	NA	35.7%	
Under 5 years	205	164	-20.0%	5.8%	Married Couple Family	399	409	2.5%	44.6%	
5 to 9 years	177	162	-8.5%	5.7%	With Own Children Under 18	NA	215	NA	23.4%	
10 to 14 years	164	177	7.9%	6.3%	Female Householder, no husband present	NA	111	NA	12.1%	
15 to 19 years	135	194	43.7%	6.9%	With Own Children Under 18	NA	87	NA	9.5%	
20 to 24 years	210	178	-15.2%	6.3%	Average Household Size	2.47	2.40	NA	0.3%	
25 to 34 years	611	431	-29.5%	15.2%	Average Family Size	NA	3.04	NA	0.3%	
35 to 44 years	563	585	3.9%	20.7%	<b>Total Housing Units</b>	1,010	1,058	NA	115.4%	
45 to 54 years	282	501	77.7%	17.7%	Occupied Housing Units	886	917	3.5%	100.0%	
55 to 59 years	79	146	84.8%	5.2%	Vacant Housing Units	124	141	13.7%	15.4%	
60 to 64 years	104	81	-22.1%	2.9%	Seasonal, Recreational, Occasional Use	27	63	133.3%	6.9%	
65 to 74 years	115	134	16.5%	4.7%	Owner Vacancy Rate	NA	2.5%	NA	NA	
75 to 84 years	39	56	43.6%	2.0%	Rental Vacancy Rate	NA	8.4%	NA	NA	
85 years and over	15	21	40.0%	0.7%	Owner Occupied Units	420	461	9.8%	50.3%	
Median Age	32.6	37.1	13.8%	NA	Renter Occupied Units	466	456	-2.1%	49.7%	
18 Years and Over	643	2,210	243.7%	78.1%	<b>Marital Status (over 15)</b>	NA	2,320	NA	NA	
Male		1,381	NA	NA	Never married	NA	734	NA	31.6%	
Female		829	NA	NA	Married except separated	NA	1,078	NA	46.5%	
65 Years and Over	169	211	24.9%	7.5%	Separated	NA	43	NA	1.9%	
Male		99	NA	NA	Widowed	NA	119	NA	5.1%	
Female		112	NA	NA	Divorced	NA	346	NA	14.9%	
<b>Place of Birth</b>					<b>Disabled, Noninstitutionalized</b>					
Native Born	2,593	2,695	3.9%	95.2%	Population 5 to 20	NA	551	NA	100.0%	
Born in Alaska	NA	1,081	NA	38.2%	With a Disability	NA	33	NA	6.0%	
Born in other state	NA	1,594	NA	56.3%	Population 21 to 64	NA	1,414	NA	100.0%	
Foreign Born	106	135	27.4%	4.8%	With a Disability	NA	271	NA	19.2%	
Naturalized Citizen	NA	81	NA	2.9%	Percent Employed	NA	49.4%	NA	NA	
Not a Citizen	NA	54	NA	1.9%	Without a Disability	NA	1,143	NA	80.8%	
<b>Veteran Status</b>					Percent Employed	NA	70.5%	NA	NA	
Civilian veterans	436	404	-7.3%	18.5%	<b>Income in 1999 - Families</b>					
<b>Educational Attainment</b>					Total	553				
Population 25 years and over					1,956	Less than \$10,000	35	29	-17.1%	5.2%
Less than 9th grade	54	61	13.0%	3.1%	\$10,000 - \$14,999	28	33	17.9%	6.0%	
9th-12th, no diploma	157	200	27.4%	10.2%	\$15,000 - \$24,999	67	50	-25.4%	9.0%	
High School Diploma	696	748	7.5%	38.2%	\$25,000 - \$34,999	68	53	-22.1%	9.6%	
College, no degree	510	521	2.2%	26.6%	\$35,000 - \$49,999	91	73	-19.8%	13.2%	
Associate Degree	110	115	4.5%	5.9%	\$50,000 - \$74,999	114	155	36.0%	28.0%	
Bachelor's Degree	181	198	9.4%	10.1%	\$75,000 - \$99,999	76	79	3.9%	14.3%	
Graduate, Profess Degree	97	113	16.5%	5.8%	\$100,000 - \$149,999	41	55	34.1%	9.9%	
Percent HS Grad	88.3%	86.7%	-1.8%	NA	\$150,000 - \$199,999	16	17	6.3%	3.1%	
Percent Bachelor's +	15.4%	15.9%	3.2%	NA	\$200,000 or more	NA	9	NA	1.6%	
					Median Income - \$	47,500	54,904	15.6%	NA	

Table 5.15

# Soldotna Sales

<b>Soldotna 2nd Quarter GROSS Sales by Industry - 1999-2005 - in \$</b>								
	1999	2000	2001	2002	2003	2004	2005	Annual Change
Ag, Forestry, Fish	228,635	379,092	486,756	493,143	558,058	645,572	1,027,906	59.2%
Mining	103,776	80,235	77,886	106,949	122,012	154,892	185,929	20.0%
Construction	3,171,056	4,925,887	4,464,446	4,934,965	3,954,148	5,879,390	4,168,075	-29.1%
Manufacturing	764,920	1,149,365	1,611,027	1,727,614	2,288,148	1,132,457	1,352,876	19.5%
Trans, Comm, Pub Util	4,379,100	3,684,195	4,573,146	3,531,451	3,827,252	4,716,238	4,974,094	5.5%
Wholesale	6,802,549	8,721,917	6,981,240	7,353,520	9,554,591	8,967,548	2,653,447	-70.4%
Retail	42,762,715	42,547,382	45,690,237	49,060,629	52,189,612	54,023,404	57,022,596	5.6%
Finance, Ins, RE	2,036,799	2,743,036	2,223,114	2,983,720	2,547,857	2,956,541	3,005,670	1.7%
Services	7,618,629	8,278,327	8,929,421	9,561,798	10,128,839	10,824,252	10,531,672	-2.7%
Government	6,763	5,779	5,238	7,859	8,680	8,521	8,502	-0.2%
<b>Total</b>	<b>67,874,942</b>	<b>72,515,215</b>	<b>75,042,511</b>	<b>79,761,648</b>	<b>85,179,197</b>	<b>89,308,815</b>	<b>84,930,767</b>	<b>-4.9%</b>
<b>Annual Change</b>		<b>6.8%</b>	<b>3.5%</b>	<b>6.3%</b>	<b>6.8%</b>	<b>4.8%</b>	<b>-4.9%</b>	

Table 6.1

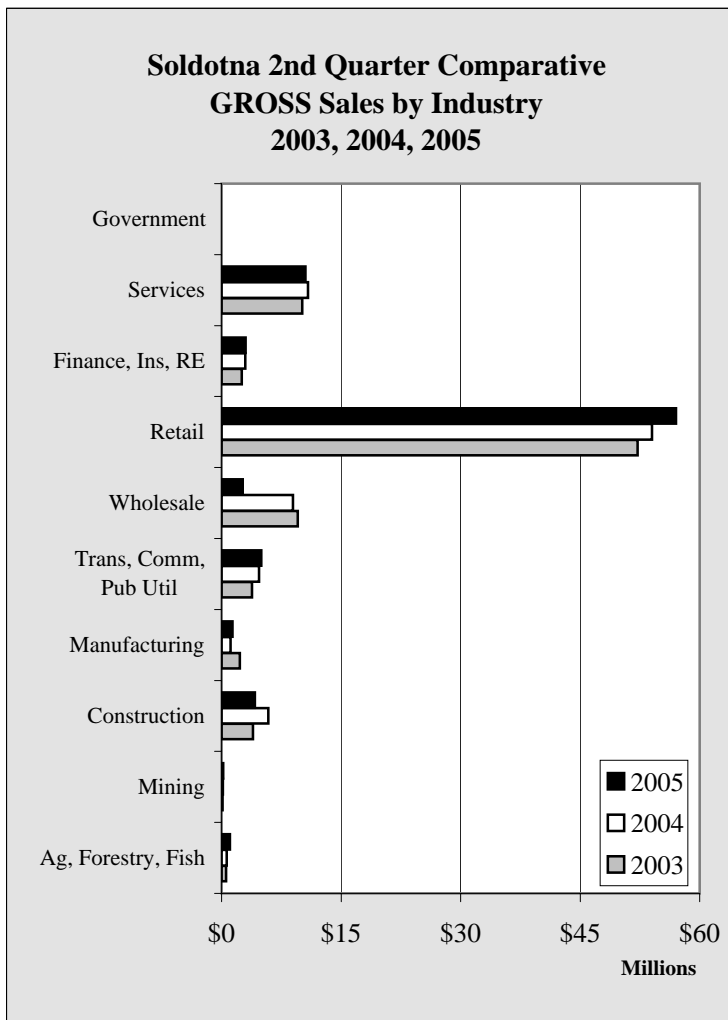

Chart 6.1

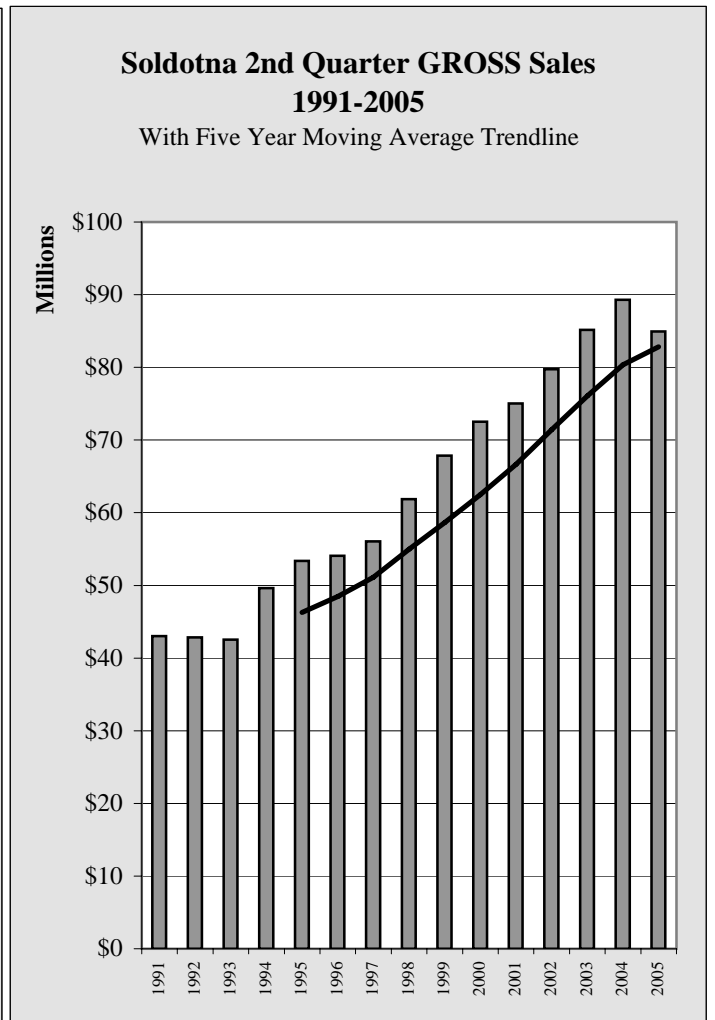

Chart 6.2

# Soldotna Sales

<b>Soldotna 2nd Quarter TAXABLE Sales by Industry - 1999-2005 - in \$</b>								
	1999	2000	2001	2002	2003	2004	2005	Annual Change
Ag, Forestry, Fish	170,588	227,222	314,053	286,565	297,426	270,912	263,246	-2.8%
Mining	2,450	6,707	10,242	7,414	7,401	5,828	7,089	21.6%
Construction	391,321	290,180	301,807	329,803	430,437	377,000	376,169	-0.2%
Manufacturing	371,397	412,829	465,257	429,327	436,364	375,725	404,803	7.7%
Trans, Comm, Pub Util	2,502,149	2,571,379	2,584,818	2,619,156	2,964,183	2,985,335	2,791,932	-6.5%
Wholesale	80,275	229,376	282,881	231,064	288,627	254,535	262,964	3.3%
Retail	29,826,099	29,942,234	33,538,956	33,723,015	36,976,302	38,707,449	41,420,387	7.0%
Finance, Ins, RE	913,453	1,066,696	1,222,567	1,266,667	1,151,616	1,130,865	1,038,171	-8.2%
Services	3,940,745	4,014,214	4,188,255	4,603,064	4,457,613	4,894,259	4,525,075	-7.5%
Government	6,763	5,779	5,238	7,859	8,680	8,521	8,502	-0.2%
<b>Total</b>	<b>38,205,240</b>	<b>38,766,616</b>	<b>42,914,074</b>	<b>43,503,934</b>	<b>47,018,649</b>	<b>49,010,429</b>	<b>51,098,338</b>	<b>4.3%</b>
Annual Change		1.5%	10.7%	1.4%	8.1%	4.2%	4.3%	

Table 6.2

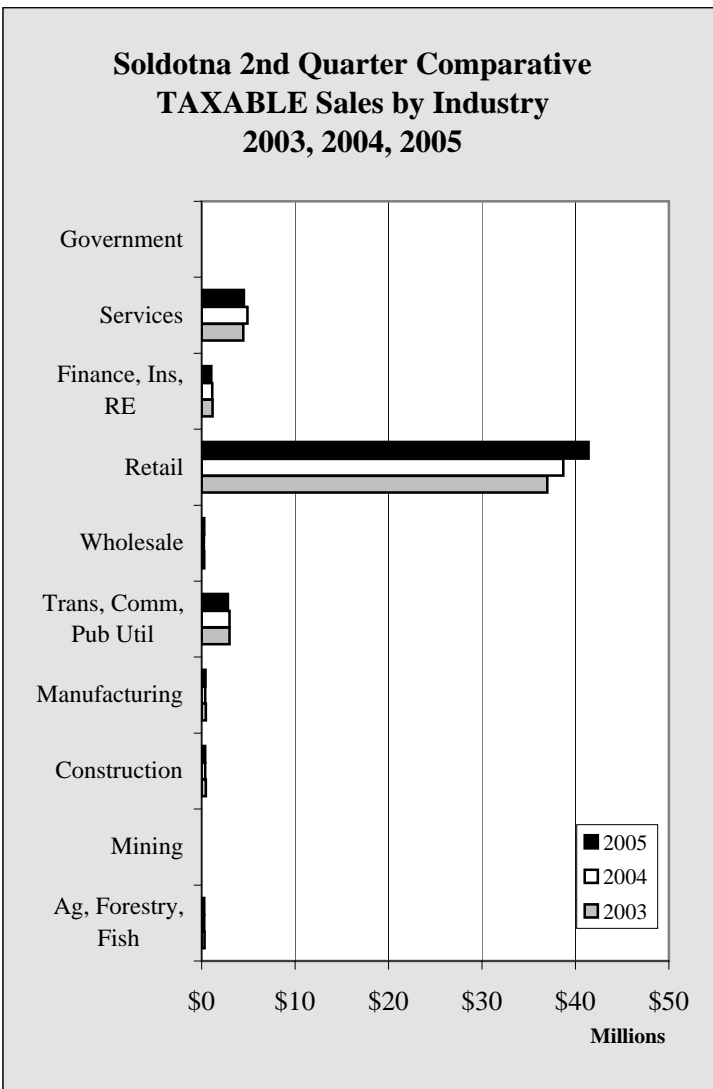

Chart 6.3

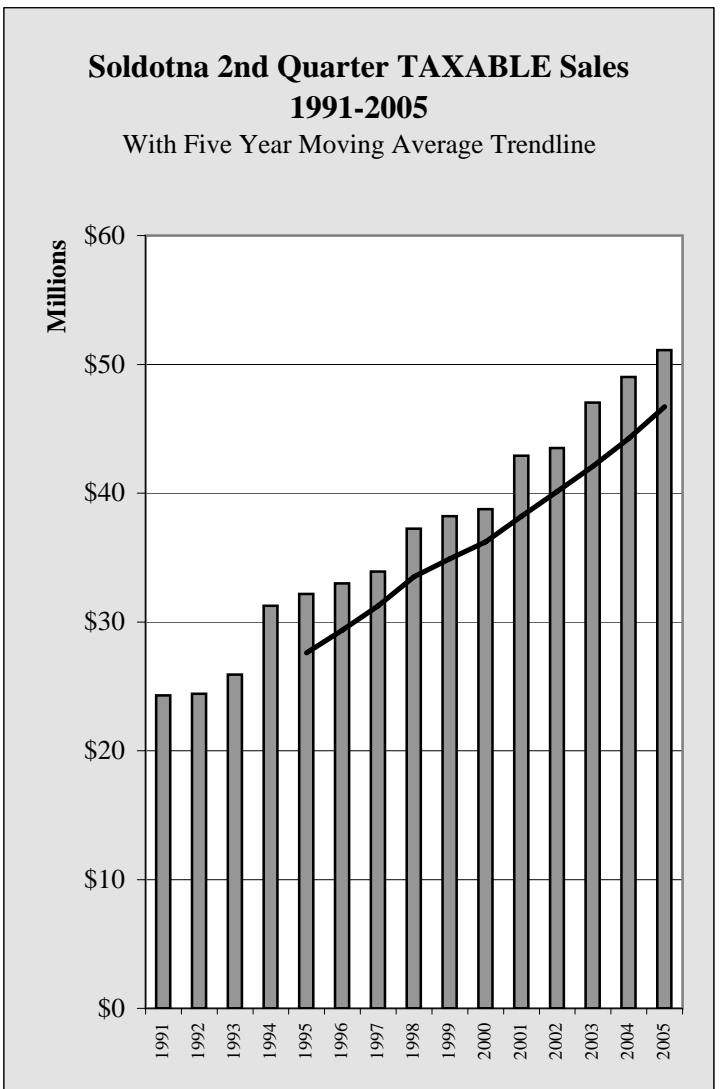

Chart 6.4

# Soldotna Sales

Soldotna YTD 6/30 GROSS Sales by Industry - 1999-2005 - in \$								
	1999	2000	2001	2002	2003	2004	2005	Annual Change
Ag, Forestry, Fish	326,589	537,274	701,976	724,497	845,479	1,202,557	1,606,359	33.6%
Mining	150,828	151,497	127,358	205,050	232,641	247,073	275,968	11.7%
Construction	5,478,677	7,970,298	8,479,817	8,163,007	7,952,066	8,836,233	8,795,618	-0.5%
Manufacturing	1,246,224	1,790,910	2,578,965	2,628,508	3,417,539	1,676,240	1,866,624	11.4%
Trans, Comm, Pub Util	8,370,737	7,723,804	9,337,601	7,217,176	8,038,579	9,513,194	10,369,947	9.0%
Wholesale	12,602,036	16,000,696	13,808,302	15,425,570	16,863,880	18,687,699	4,744,170	-74.6%
Retail	73,276,500	74,075,518	80,405,486	85,547,876	88,977,313	93,630,319	97,928,656	4.6%
Finance, Ins, RE	4,136,959	4,719,431	4,389,995	5,241,923	5,009,155	5,989,462	5,804,319	-3.1%
Services	13,696,783	14,734,617	16,003,543	16,925,232	18,055,264	19,422,101	19,464,540	0.2%
Government	19,589	13,066	11,745	14,559	20,999	15,425	10,399	-32.6%
Total	119,304,922	127,717,111	135,844,788	142,093,398	149,412,915	159,220,303	150,866,600	-5.2%
Annual Change		7.1%	6.4%	4.6%	5.2%	6.6%	-5.2%	

Table 6.3

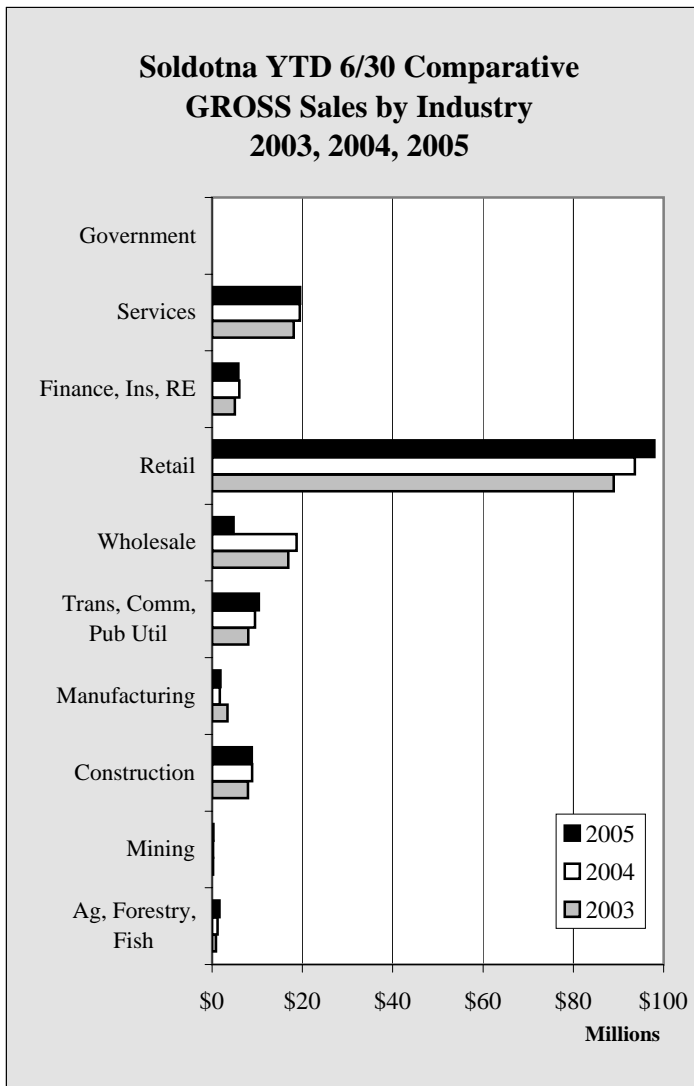

Chart 6.5

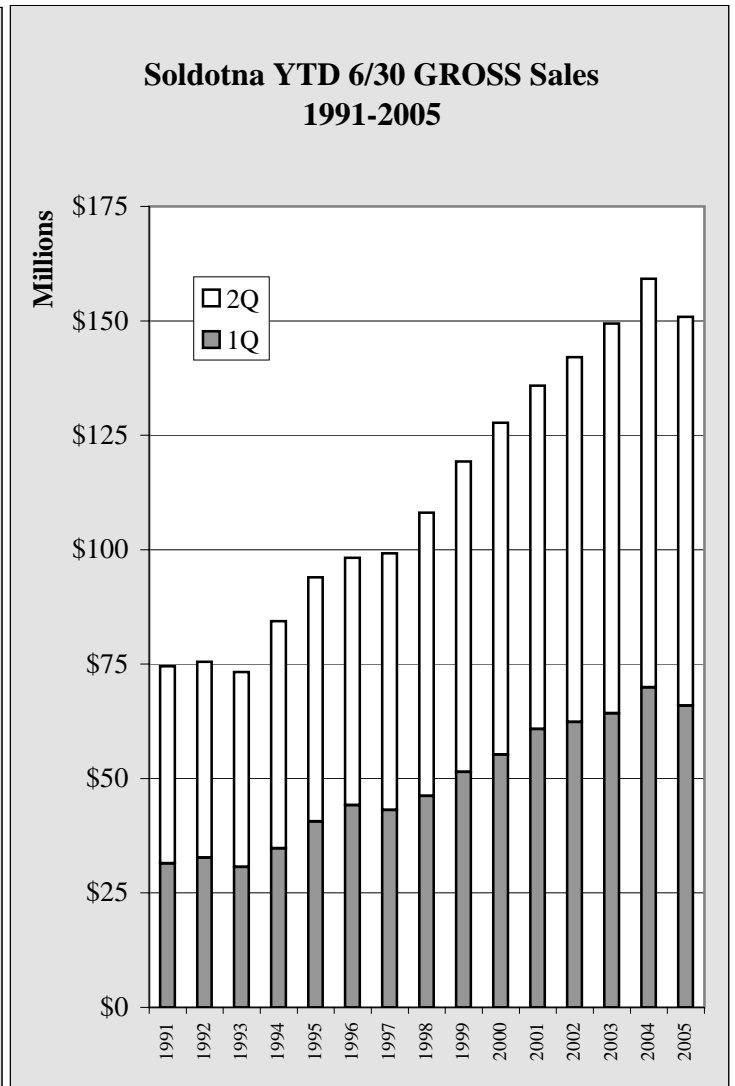

Chart 6.6

# Soldotna Sales

<b>Soldotna YTD 6/30 TAXABLE Sales by Industry - 1999-2005 - in \$</b>								
	1999	2000	2001	2002	2003	2004	2005	Annual Change
Ag, Forestry, Fish	265,144	375,326	497,909	471,817	465,019	490,143	443,941	-9.4%
Mining	2,450	7,855	17,854	13,861	16,775	12,503	13,234	5.8%
Construction	686,584	606,180	536,325	612,902	732,197	693,960	707,343	1.9%
Manufacturing	571,067	607,387	665,223	610,813	656,069	573,566	594,577	3.7%
Trans, Comm, Pub Util	5,047,068	5,180,128	5,169,011	5,371,429	6,183,218	6,323,533	6,093,412	-3.6%
Wholesale	140,189	300,589	407,518	366,501	461,680	408,588	381,830	-6.5%
Retail	51,151,405	52,365,902	58,569,101	59,293,541	62,745,676	67,247,076	71,499,636	6.3%
Finance, Ins, RE	1,771,466	1,927,107	2,294,601	2,437,300	2,293,035	2,091,957	2,005,683	-4.1%
Services	6,990,206	7,047,496	7,237,164	8,047,819	7,907,603	8,537,006	8,082,136	-5.3%
Government	19,589	13,066	11,745	14,559	20,999	15,425	10,399	-32.6%
<b>Total</b>	<b>66,645,168</b>	<b>68,431,036</b>	<b>75,406,451</b>	<b>77,240,542</b>	<b>81,482,271</b>	<b>86,393,757</b>	<b>89,832,191</b>	<b>4.0%</b>
Annual Change		2.7%	10.2%	2.4%	5.5%	6.0%	4.0%	

Table 6.4

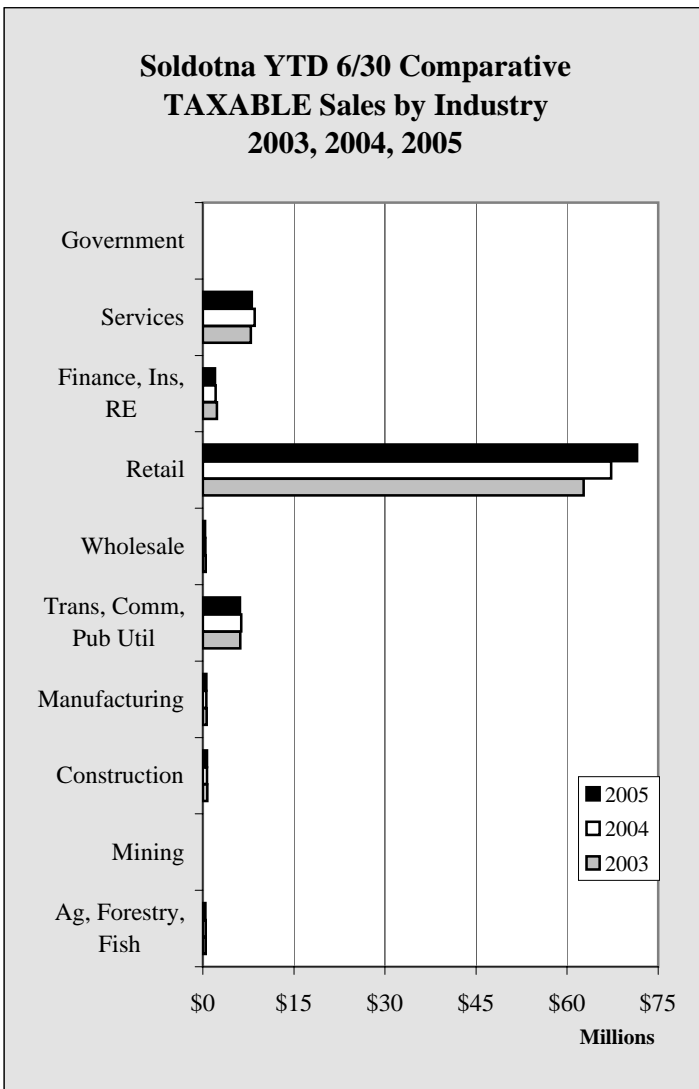

Chart 6.7

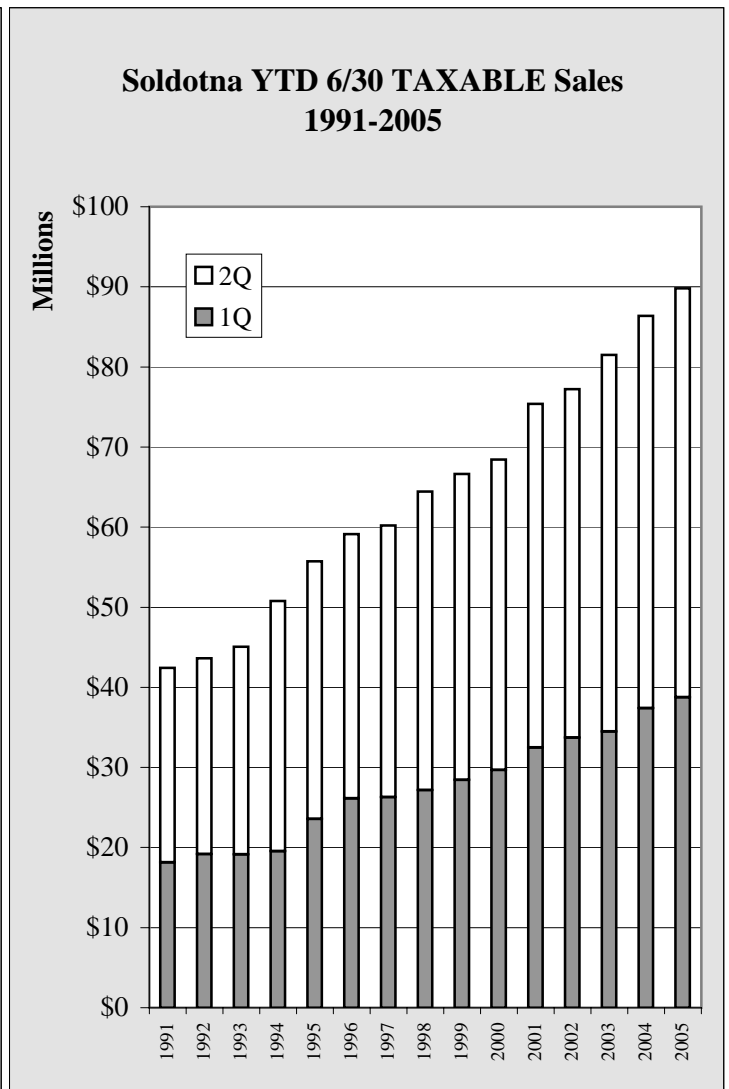

Chart 6.8

# Soldotna Sales

<b>Soldotna Annual GROSS Sales by Industry - 1998-2004 - in \$</b>								
	1998	1999	2000	2001	2002	2003	2004	Annual Change
Ag, Forestry, Fish	689,389	954,143	1,727,448	1,664,917	1,853,591	2,523,473	3,223,216	27.7%
Mining	2,729,541	306,689	305,525	305,091	410,684	450,504	548,472	21.7%
Construction	20,205,240	17,075,443	20,761,485	19,395,458	22,467,091	20,813,302	27,758,931	33.4%
Manufacturing	3,192,979	3,210,218	5,446,988	5,938,040	6,301,658	7,729,281	4,338,040	-43.9%
Trans, Comm, Pub Util	14,308,591	17,467,668	15,708,998	17,799,215	15,900,605	16,342,600	20,221,946	23.7%
Wholesale	14,626,150	32,515,047	32,610,279	31,467,653	40,201,769	34,368,869	28,770,110	-16.3%
Retail	157,774,054	166,898,488	170,201,586	187,606,859	191,944,180	204,741,275	217,650,893	6.3%
Finance, Ins, RE	7,365,455	8,509,983	10,210,170	10,232,574	10,465,959	10,733,557	11,881,330	10.7%
Services	29,884,044	30,622,659	32,265,770	34,689,321	36,330,903	40,028,395	46,781,728	16.9%
Government	18,221	28,399	17,062	19,103	22,579	41,717	20,979	-49.7%
<b>Total</b>	<b>250,793,664</b>	<b>277,588,737</b>	<b>289,255,311</b>	<b>309,118,231</b>	<b>325,899,019</b>	<b>337,772,973</b>	<b>361,195,645</b>	<b>6.9%</b>
Annual Change		10.7%	4.2%	6.9%	5.4%	3.6%	6.9%	

Table 6.5

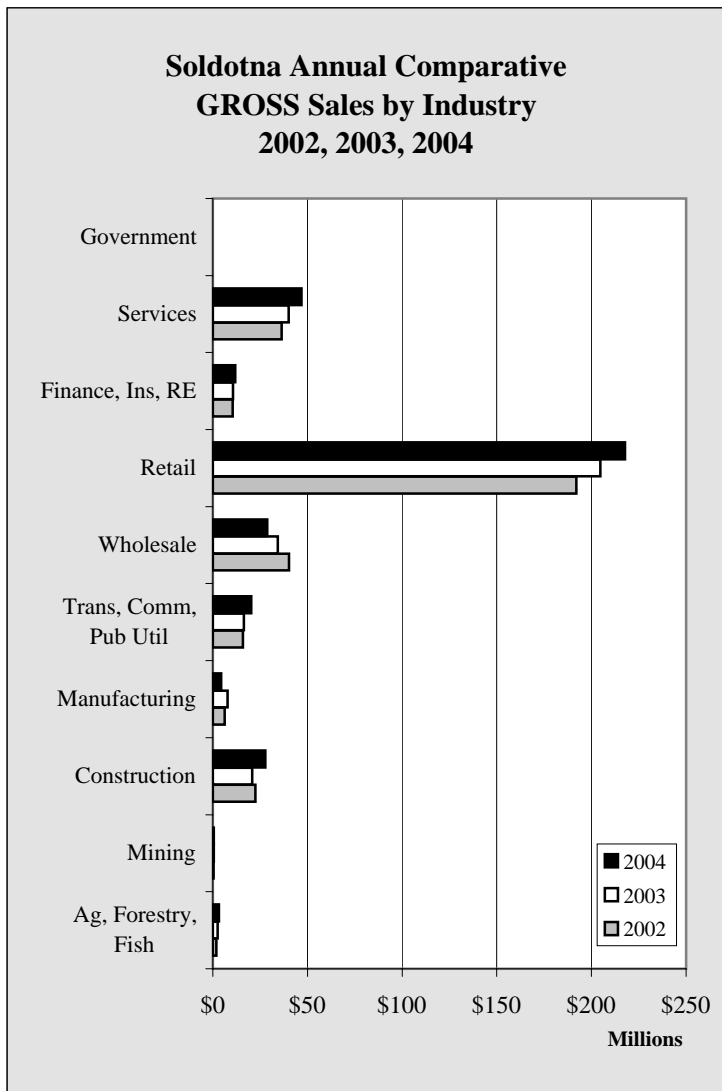

Chart 6.9

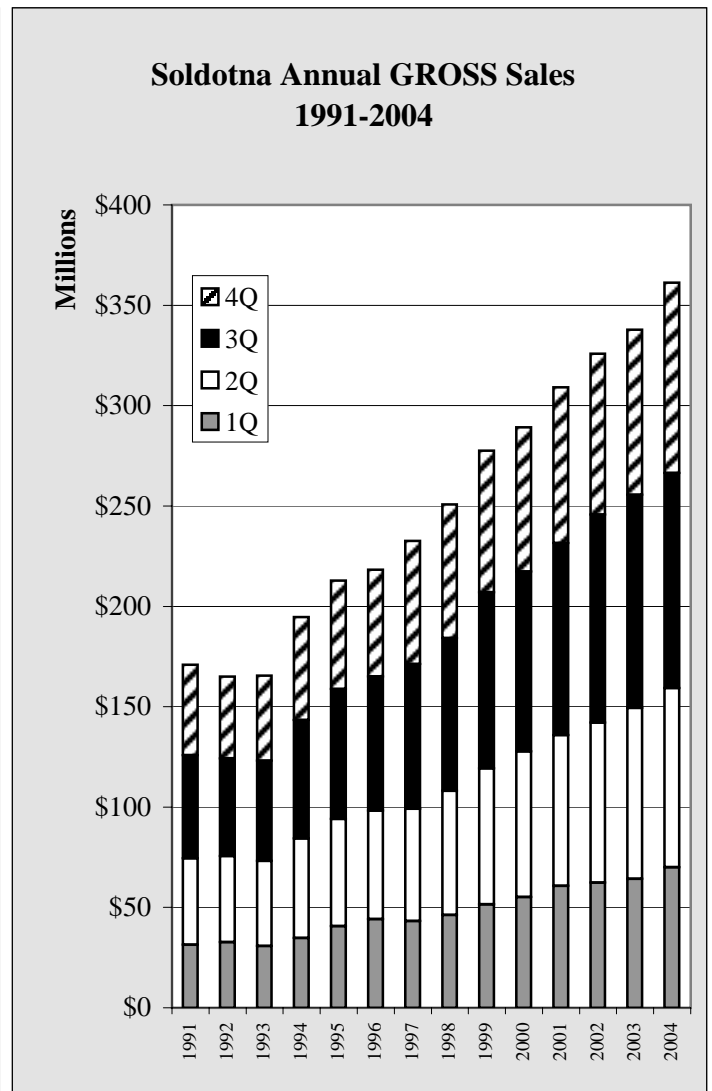

Chart 6.10

# Soldotna Sales

<b>Soldotna Annual TAXABLE Sales by Industry - 1998-2004 - in \$</b>								
	1998	1999	2000	2001	2002	2003	2004	Annual Change
Ag, Forestry, Fish	466,912	697,062	921,908	1,117,793	1,043,812	1,176,634	1,123,088	-4.6%
Mining	8,010	5,675	11,333	35,080	33,278	33,067	20,326	-38.5%
Construction	1,320,297	1,471,239	1,233,755	1,173,265	1,317,838	1,590,497	1,412,936	-11.2%
Manufacturing	1,439,440	1,467,864	1,567,147	1,638,254	1,635,572	1,674,325	1,663,082	-0.7%
Trans, Comm, Pub Util	9,374,360	10,378,566	10,311,502	10,527,433	11,178,060	12,295,182	12,421,267	1.0%
Wholesale	369,062	322,925	715,161	786,443	763,236	997,320	805,376	-19.2%
Retail	115,732,671	122,401,180	124,618,575	136,194,643	138,178,507	151,168,576	159,827,563	5.7%
Finance, Ins, RE	3,662,452	3,776,435	4,545,775	5,207,613	5,279,203	4,435,121	4,396,348	-0.9%
Services	15,398,236	15,403,419	15,493,910	15,718,811	17,525,783	17,204,443	18,361,846	6.7%
Government	18,221	28,399	17,062	19,103	22,579	41,717	20,979	-49.7%
<b>Total</b>	<b>147,789,661</b>	<b>155,952,764</b>	<b>159,436,128</b>	<b>172,418,438</b>	<b>176,977,868</b>	<b>190,616,882</b>	<b>200,052,811</b>	<b>5.0%</b>
Annual Change		5.5%	2.2%	8.1%	2.6%	7.7%	5.0%	

Table 6.6

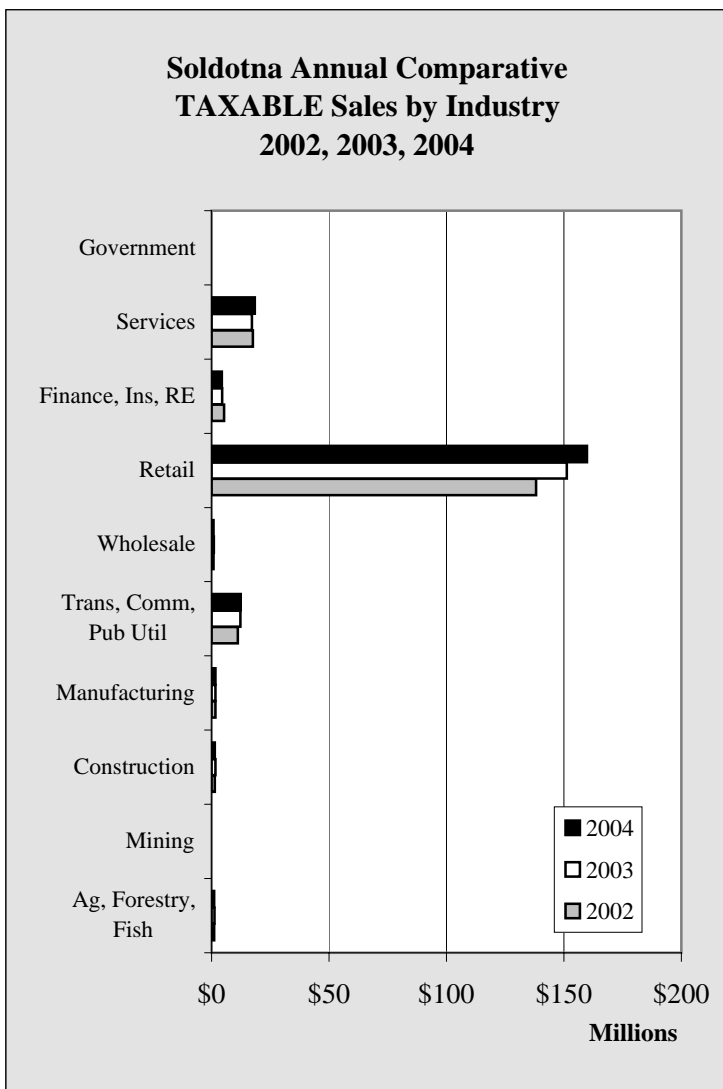

Chart 6.11

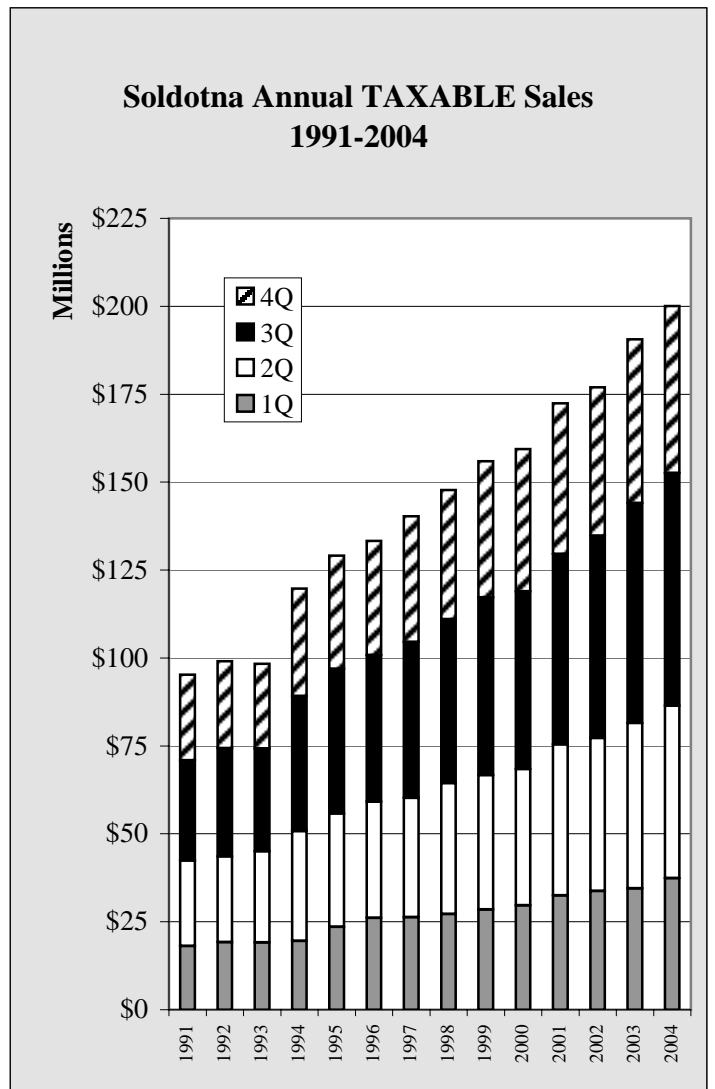

Chart 6.12



# Soldotna Sales

<b>Soldotna GROSS Sales by Industry by Quarter - 2002-2005 - in \$</b>					
	1st Quarter	2nd Quarter	3rd Quarter	4th Quarter	Total
<b>2002</b>					
Ag, Forestry, Fish	231,354	493,143	667,821	461,273	1,853,591
Mining	98,101	106,949	86,164	119,470	410,684
Construction	3,228,042	4,934,965	8,313,280	5,990,804	22,467,091
Manufacturing	900,894	1,727,614	2,352,093	1,321,057	6,301,658
Trans, Comm, Pub Util	3,685,725	3,531,451	4,900,494	3,782,935	15,900,605
Wholesale	8,072,050	7,353,520	12,524,522	12,251,677	40,201,769
Retail	36,487,247	49,060,629	60,884,442	45,511,862	191,944,180
Finance, Ins, RE	2,258,203	2,983,720	2,591,812	2,632,224	10,465,959
Services	7,363,434	9,561,798	11,299,921	8,105,750	36,330,903
Government	6,700	7,859	4,290	3,730	22,579
<b>Total</b>	<b>62,331,750</b>	<b>79,761,648</b>	<b>103,624,839</b>	<b>80,180,782</b>	<b>325,899,019</b>
<b>2003</b>					
Ag, Forestry, Fish	287,421	558,058	920,446	757,548	2,523,473
Mining	110,629	122,012	99,139	118,724	450,504
Construction	3,997,918	3,954,148	6,734,379	6,126,857	20,813,302
Manufacturing	1,129,391	2,288,148	2,843,498	1,468,244	7,729,281
Trans, Comm, Pub Util	4,211,327	3,827,252	3,716,921	4,587,100	16,342,600
Wholesale	7,309,289	9,554,591	10,562,562	6,942,427	34,368,869
Retail	36,787,701	52,189,612	66,012,371	49,751,591	204,741,275
Finance, Ins, RE	2,461,298	2,547,857	2,821,665	2,902,737	10,733,557
Services	7,926,425	10,128,839	12,481,767	9,491,364	40,028,395
Government	12,319	8,680	12,192	8,526	41,717
<b>Total</b>	<b>64,233,718</b>	<b>85,179,197</b>	<b>106,204,940</b>	<b>82,155,118</b>	<b>337,772,973</b>
<b>2004</b>					
Ag, Forestry, Fish	556,985	645,572	1,043,046	977,613	3,223,216
Mining	92,181	154,892	136,149	165,250	548,472
Construction	2,956,843	5,879,390	9,245,159	9,677,539	27,758,931
Manufacturing	543,783	1,132,457	1,857,842	803,958	4,338,040
Trans, Comm, Pub Util	4,796,956	4,716,238	5,692,042	5,016,710	20,221,946
Wholesale	9,720,151	8,967,548	3,326,912	6,755,499	28,770,110
Retail	39,606,915	54,023,404	70,300,859	53,719,715	217,650,893
Finance, Ins, RE	3,032,921	2,956,541	2,822,065	3,069,803	11,881,330
Services	8,597,849	10,824,252	12,761,242	14,598,385	46,781,728
Government	6,904	8,521	2,880	2,674	20,979
<b>Total</b>	<b>69,911,488</b>	<b>89,308,815</b>	<b>107,188,196</b>	<b>94,787,146</b>	<b>361,195,645</b>
<b>2005</b>					
				<b>Year to Date</b>	
Ag, Forestry, Fish	578,453	1,027,906			1,606,359
Mining	90,039	185,929			275,968
Construction	4,627,543	4,168,075			8,795,618
Manufacturing	513,748	1,352,876			1,866,624
Trans, Comm, Pub Util	5,395,853	4,974,094			10,369,947
Wholesale	2,090,723	2,653,447			4,744,170
Retail	40,906,060	57,022,596			97,928,656
Finance, Ins, RE	2,798,649	3,005,670			5,804,319
Services	8,932,868	10,531,672			19,464,540
Government	1,897	8,502			10,399
<b>Total</b>	<b>65,935,833</b>	<b>84,930,767</b>			<b>150,866,600</b>

Table 6.7

# Soldotna Sales

<b>Soldotna TAXABLE Sales by Industry by Quarter - 2002-2005 - in \$</b>					
	1st Quarter	2nd Quarter	3rd Quarter	4th Quarter	Total
<b>2002</b>					
Ag, Forestry, Fish	185,252	286,565	393,521	178,474	1,043,812
Mining	6,447	7,414	7,836	11,581	33,278
Construction	283,099	329,803	369,398	335,538	1,317,838
Manufacturing	181,486	429,327	710,329	314,430	1,635,572
Trans, Comm, Pub Util	2,752,273	2,619,156	2,944,886	2,861,745	11,178,060
Wholesale	135,437	231,064	251,226	145,509	763,236
Retail	25,570,526	33,723,015	45,546,360	33,338,606	138,178,507
Finance, Ins, RE	1,170,633	1,266,667	1,502,411	1,339,492	5,279,203
Services	3,444,755	4,603,064	5,758,366	3,719,598	17,525,783
Government	6,700	7,859	4,290	3,730	22,579
<b>Total</b>	<b>33,736,608</b>	<b>43,503,934</b>	<b>57,488,623</b>	<b>42,248,703</b>	<b>176,977,868</b>
<b>2003</b>					
Ag, Forestry, Fish	167,593	297,426	457,868	253,747	1,176,634
Mining	9,374	7,401	7,885	8,407	33,067
Construction	301,760	430,437	465,297	393,003	1,590,497
Manufacturing	219,705	436,364	739,665	278,591	1,674,325
Trans, Comm, Pub Util	3,219,035	2,964,183	2,959,644	3,152,320	12,295,182
Wholesale	173,053	288,627	339,309	196,331	997,320
Retail	25,769,374	36,976,302	50,742,487	37,680,413	151,168,576
Finance, Ins, RE	1,141,419	1,151,616	1,159,465	982,621	4,435,121
Services	3,449,990	4,457,613	5,692,459	3,604,381	17,204,443
Government	12,319	8,680	12,192	8,526	41,717
<b>Total</b>	<b>34,463,622</b>	<b>47,018,649</b>	<b>62,576,271</b>	<b>46,558,340</b>	<b>190,616,882</b>
<b>2004</b>					
Ag, Forestry, Fish	219,231	270,912	444,134	188,811	1,123,088
Mining	6,675	5,828	3,030	4,793	20,326
Construction	316,960	377,000	368,702	350,274	1,412,936
Manufacturing	197,841	375,725	804,097	285,419	1,663,082
Trans, Comm, Pub Util	3,338,198	2,985,335	2,949,371	3,148,363	12,421,267
Wholesale	154,053	254,535	263,334	133,454	805,376
Retail	28,539,627	38,707,449	53,991,389	38,589,098	159,827,563
Finance, Ins, RE	961,092	1,130,865	1,284,286	1,020,105	4,396,348
Services	3,642,747	4,894,259	6,071,728	3,753,112	18,361,846
Government	6,904	8,521	2,880	2,674	20,979
<b>Total</b>	<b>37,383,328</b>	<b>49,010,429</b>	<b>66,182,951</b>	<b>47,476,103</b>	<b>200,052,811</b>
<b>2005</b>					
				<b>Year to Date</b>	
Ag, Forestry, Fish	180,695	263,246			443,941
Mining	6,145	7,089			13,234
Construction	331,174	376,169			707,343
Manufacturing	189,774	404,803			594,577
Trans, Comm, Pub Util	3,301,480	2,791,932			6,093,412
Wholesale	118,866	262,964			381,830
Retail	30,079,249	41,420,387			71,499,636
Finance, Ins, RE	967,512	1,038,171			2,005,683
Services	3,557,061	4,525,075			8,082,136
Government	1,897	8,502			10,399
<b>Total</b>	<b>38,733,853</b>	<b>51,098,338</b>			<b>89,832,191</b>

Table 6.8

# Soldotna Construction

<b>Soldotna 2nd Quarter Permit VALUES by Type - 1999-2005 - in \$</b>								
	1999	2000	2001	2002	2003	2004	2005	Annual Change
Residential - New	1,453,674	1,520,491	2,363,001	2,075,293	1,899,354	1,777,087	1,916,999	7.9%
Residential - Add/Alter	181,361	224,674	151,039	339,286	130,080	74,809	141,950	89.7%
Commercial - New	2,723,818	1,583,642	0	2,601,575	2,116,490	1,366,297	4,099,828	200.1%
Commercial - Add/Alter	426,199	680,549	717,150	1,987,304	88,000	530,380	673,458	27.0%
<b>TOTAL</b>	<b>4,785,052</b>	<b>4,009,356</b>	<b>3,231,190</b>	<b>7,003,458</b>	<b>4,233,924</b>	<b>3,748,573</b>	<b>6,832,235</b>	<b>82.3%</b>
Annual Change		-16.2%	-19.4%	116.7%	-39.5%	-11.5%	82.3%	

Table 6.9

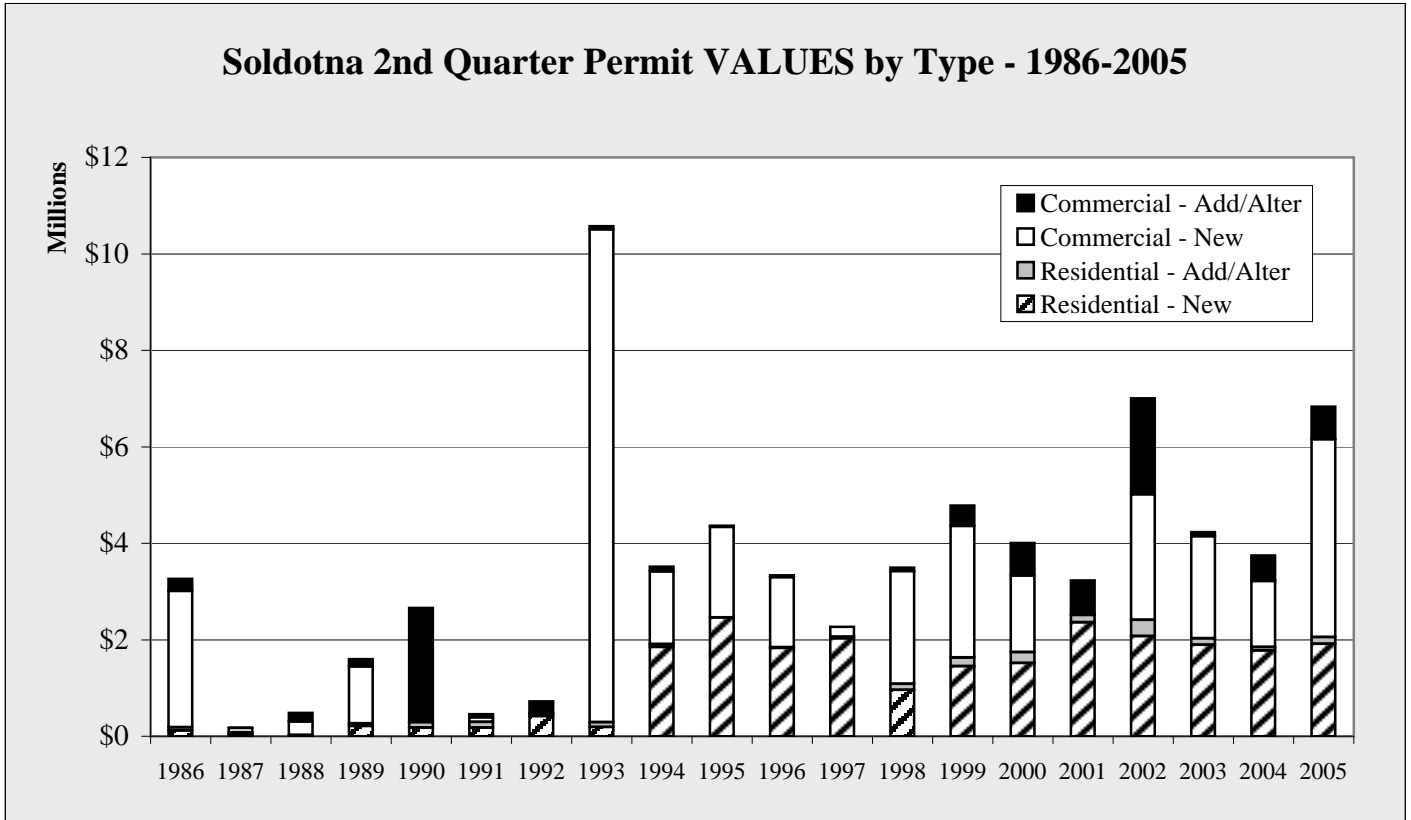

Chart 6.13

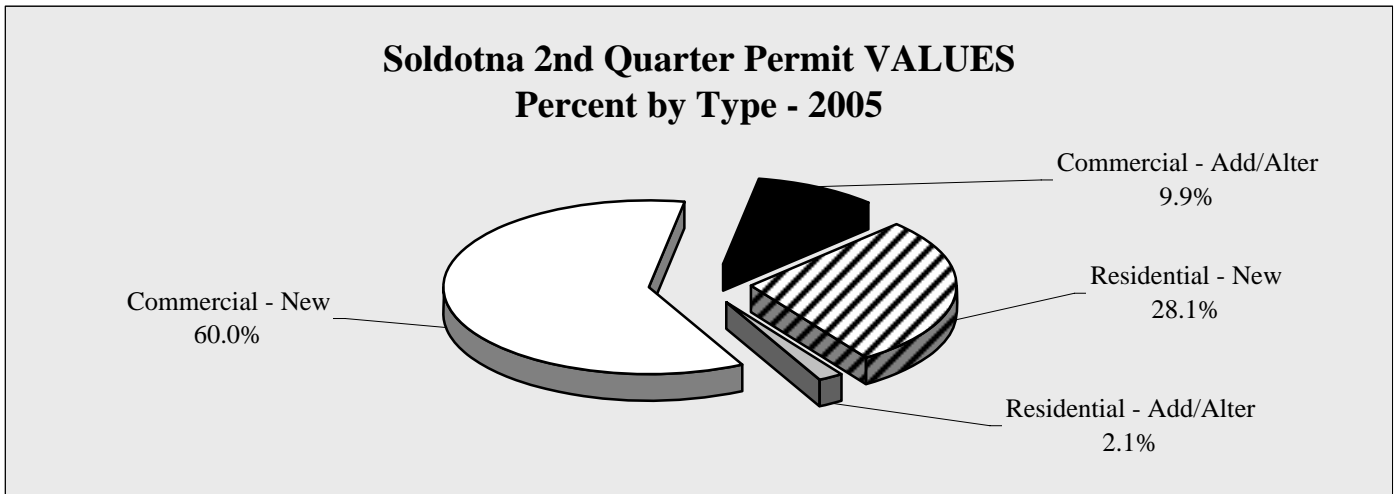

Chart 6.14

# Soldotna Construction

<b>Soldotna 2nd Quarter Permit VOLUME by Type - 1999-2005</b>								
	1999	2000	2001	2002	2003	2004	2005	Annual Change
Residential - New	10	10	14	17	15	9	11	22.2%
Residential - Add/Alter	8	9	10	6	8	8	12	50.0%
Commercial - New	8	3	0	9	6	3	9	200.0%
Commercial - Add/Alter	9	12	13	19	7	6	8	33.3%
<b>TOTAL</b>	<b>35</b>	<b>34</b>	<b>37</b>	<b>51</b>	<b>36</b>	<b>26</b>	<b>40</b>	<b>53.8%</b>
Annual Change		-2.9%	8.8%	37.8%	-29.4%	-27.8%	53.8%	

Table 6.10

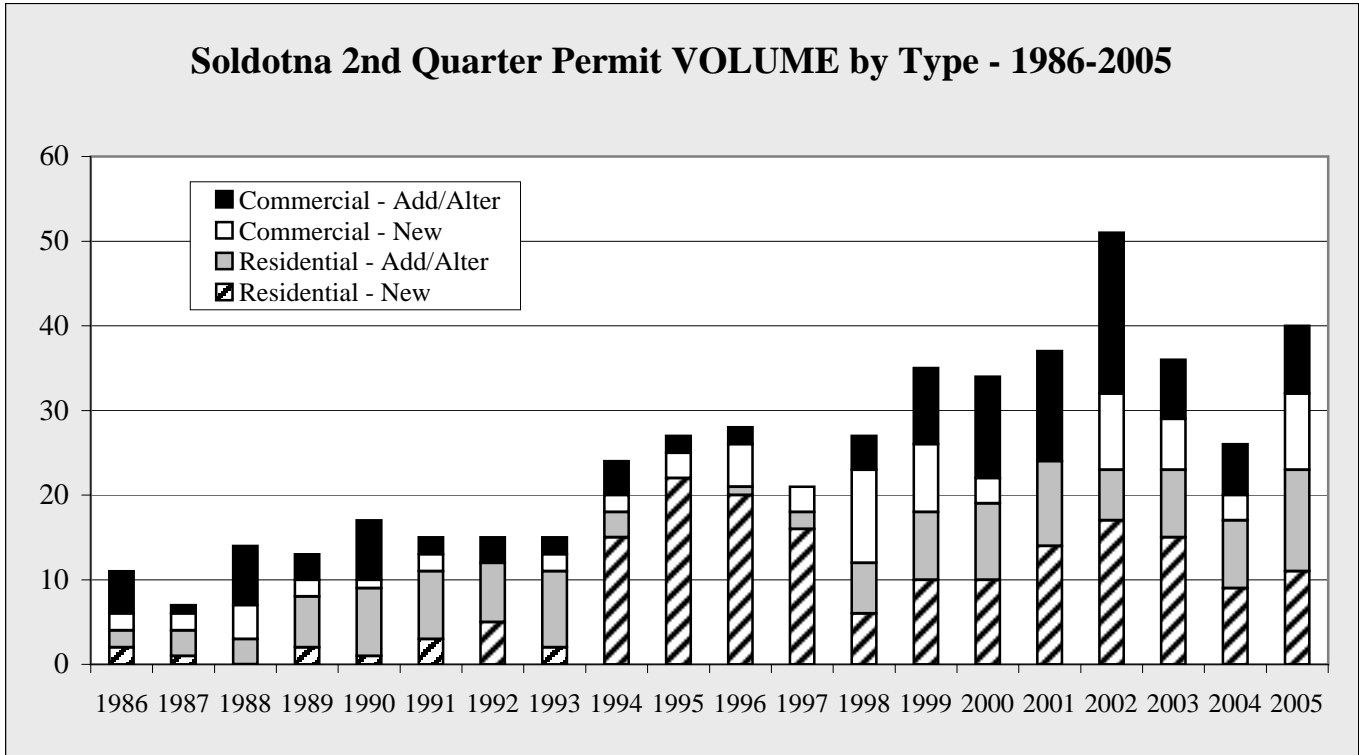

Chart 6.15

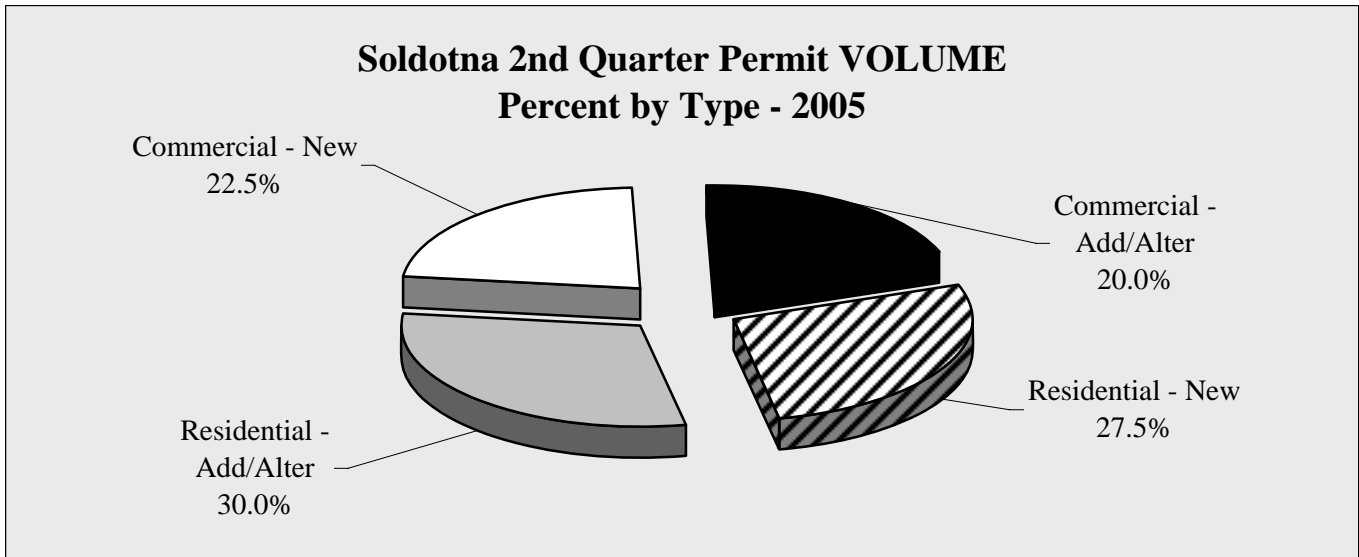

Chart 6.16

# Soldotna Construction

<b>Soldotna YTD 6/30 Permit VALUES by Type - 1999-2005 - in \$</b>								
	1999	2000	2001	2002	2003	2004	2005	Annual Change
Residential - New	1,453,674	1,894,420	2,363,001	2,316,142	1,899,354	2,316,384	2,637,955	13.9%
Residential - Add/Alter	235,361	224,674	256,199	426,221	187,907	74,809	403,580	439.5%
Commercial - New	2,723,818	2,017,915	2,658,578	3,316,381	2,116,490	5,831,323	4,294,828	-26.3%
Commercial - Add/Alter	455,895	950,549	1,004,630	2,150,304	457,191	590,380	917,427	55.4%
<b>TOTAL</b>	<b>4,868,748</b>	<b>5,087,558</b>	<b>6,282,408</b>	<b>8,209,048</b>	<b>4,660,942</b>	<b>8,812,896</b>	<b>8,253,790</b>	<b>-6.3%</b>
Annual Change		4.5%	23.5%	30.7%	-43.2%	89.1%	-6.3%	

Table 6.11

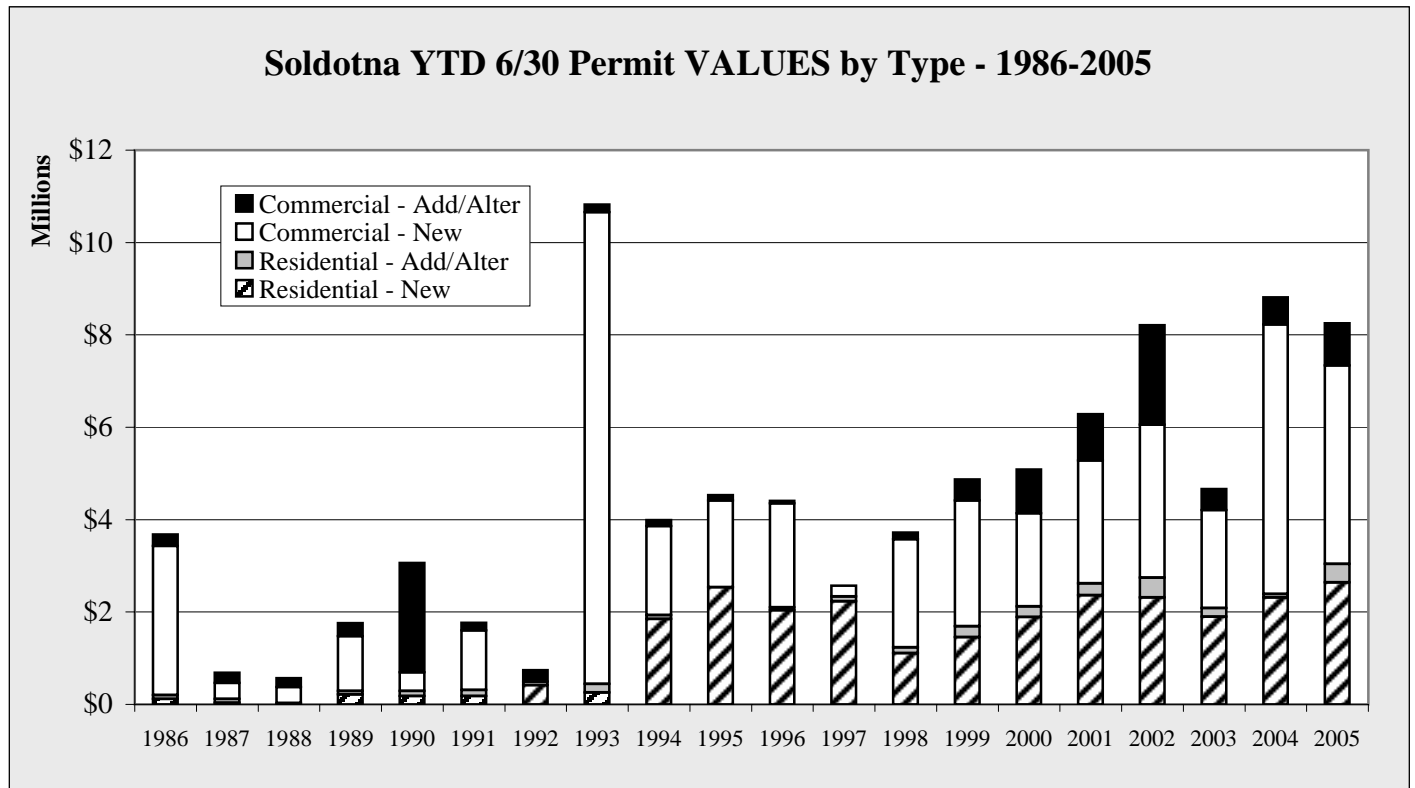

Chart 6.17

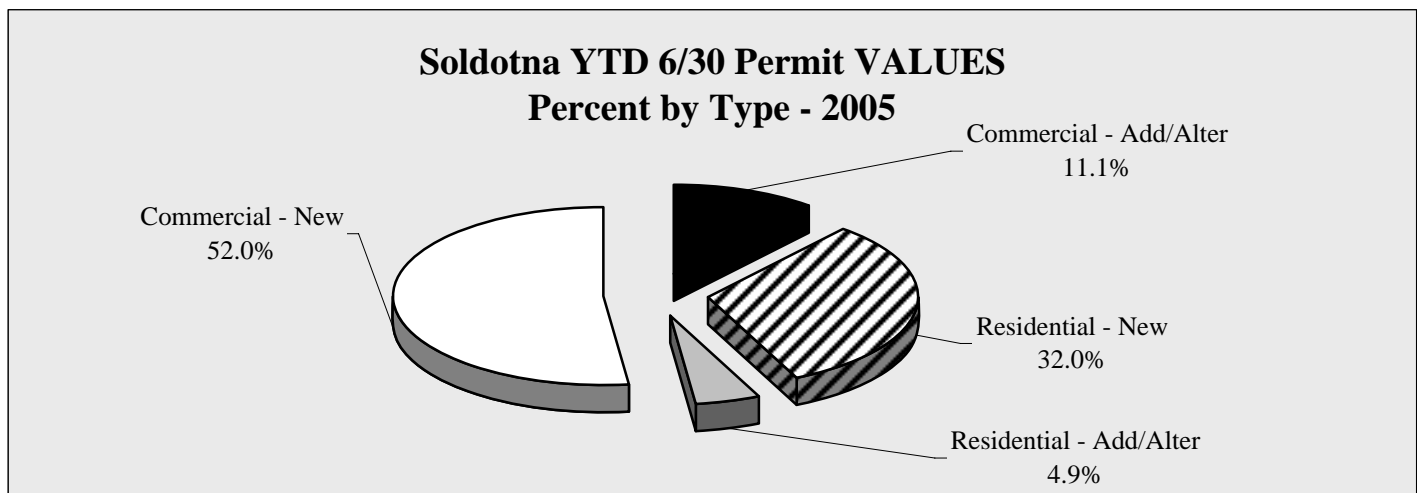

Chart 6.18

# Soldotna Construction

**Soldotna YTD 6/30 Permit VOLUME by Type - 1999-2005**

	1999	2000	2001	2002	2003	2004	2005	Annual Change
Residential - New	10	12	14	18	15	11	15	36.4%
Residential - Add/Alter	12	9	13	8	11	8	15	87.5%
Commercial - New	8	4	3	13	6	7	11	57.1%
Commercial - Add/Alter	15	17	17	23	10	9	15	66.7%
<b>TOTAL</b>	<b>45</b>	<b>42</b>	<b>47</b>	<b>62</b>	<b>42</b>	<b>35</b>	<b>56</b>	<b>60.0%</b>
Annual Change		-6.7%	11.9%	31.9%	-32.3%	-16.7%	60.0%	

Table 6.12

**Soldotna YTD 6/30 Permit VOLUME by Type - 1986-2005**

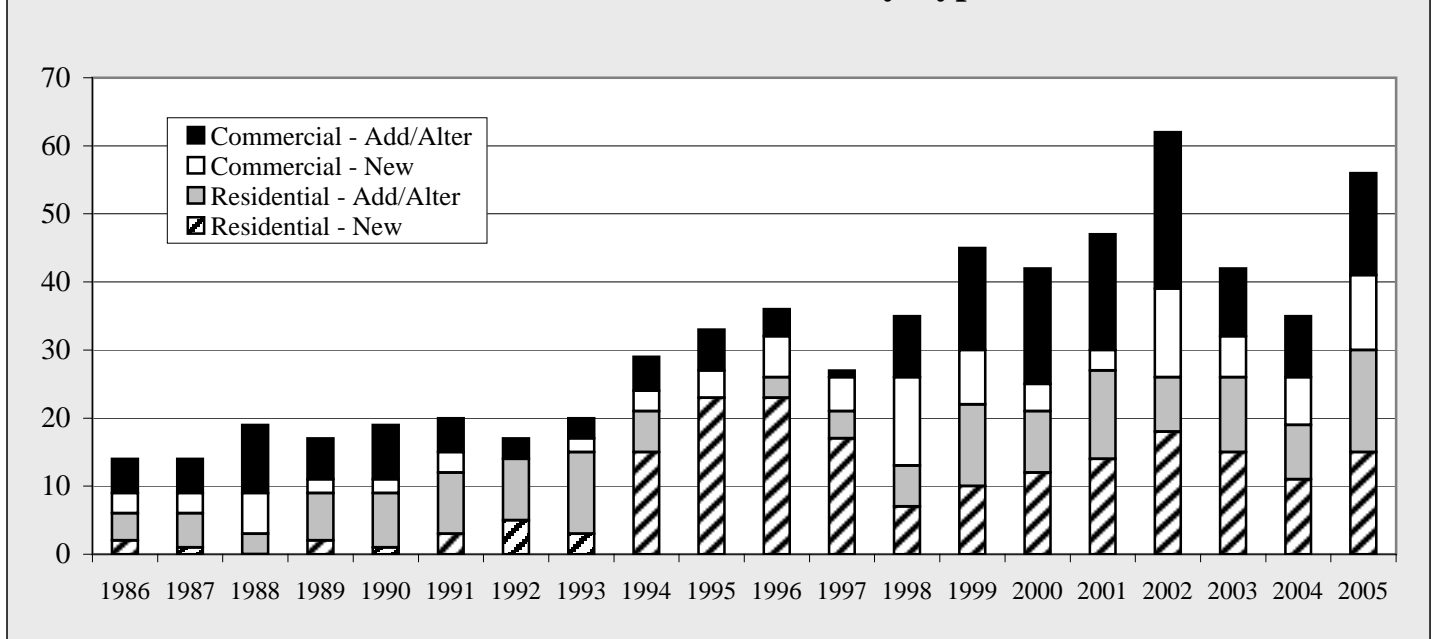

Chart 6.19

**Soldotna YTD 6/30 Permit VOLUME  
Percent by Type - 2005**

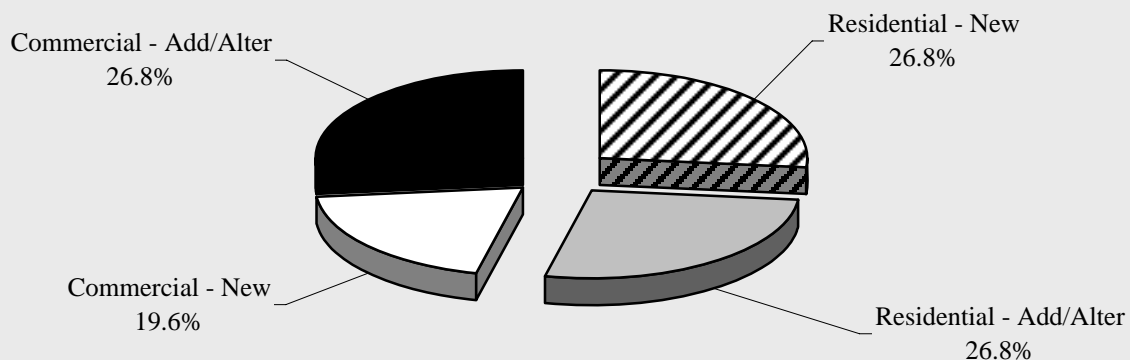

Chart 6.20

# Soldotna Construction

<b>Soldotna Annual Permit VALUES by Type by Quarter - 1998-2005 - in \$</b>					
	1st Quarter	2nd Quarter	3rd Quarter	4th Quarter	Total
<b>1998</b>					
Residential - New	145,000	965,000	1,062,000	175,000	2,347,000
Residential - Add/Alter	0	122,000	103,400	11,660	237,060
Commercial - New	6,552	2,333,400	3,250,713	300,000	5,890,665
Commercial - Add/Alter	78,542	73,000	723,050	272,500	1,147,092
<b>TOTAL</b>	<b>230,094</b>	<b>3,493,400</b>	<b>5,139,163</b>	<b>759,160</b>	<b>9,621,817</b>
<b>1999</b>					
Residential - New	0	1,453,674	1,368,900	225,888	3,048,462
Residential - Add/Alter	54,000	181,361	141,867	0	377,228
Commercial - New	0	2,723,818	2,495,816	281,905	5,501,539
Commercial - Add/Alter	29,696	426,199	119,996	2,000	577,891
<b>TOTAL</b>	<b>83,696</b>	<b>4,785,052</b>	<b>4,126,579</b>	<b>509,793</b>	<b>9,505,120</b>
<b>2000</b>					
Residential - New	373,929	1,520,491	543,930	270,668	2,709,018
Residential - Add/Alter	0	224,674	101,065	39,500	365,239
Commercial - New	434,273	1,583,642	935,665	970,484	3,924,064
Commercial - Add/Alter	270,000	680,549	96,250	122,300	1,169,099
<b>TOTAL</b>	<b>1,078,202</b>	<b>4,009,356</b>	<b>1,676,910</b>	<b>1,402,952</b>	<b>8,167,420</b>
<b>2001</b>					
Residential - New	0	2,363,001	1,510,852	0	3,873,853
Residential - Add/Alter	105,160	151,039	50,148	51,148	357,495
Commercial - New	2,658,578	0	630,244	0	3,288,822
Commercial - Add/Alter	287,480	717,150	318,672	111,500	1,434,802
<b>TOTAL</b>	<b>3,051,218</b>	<b>3,231,190</b>	<b>2,509,916</b>	<b>162,648</b>	<b>8,954,972</b>
<b>2002</b>					
Residential - New	240,849	2,075,293	689,202	176,000	3,181,344
Residential - Add/Alter	86,935	339,286	317,466	11,500	755,187
Commercial - New	714,806	2,601,575	1,080,678	0	4,397,059
Commercial - Add/Alter	163,000	1,987,304	610,000	70,000	2,830,304
<b>TOTAL</b>	<b>1,205,590</b>	<b>7,003,458</b>	<b>2,697,346</b>	<b>257,500</b>	<b>11,163,894</b>
<b>2003</b>					
Residential - New	0	1,899,354	648,388	526,191	3,073,933
Residential - Add/Alter	57,827	130,080	70,722	5,000	263,629
Commercial - New	0	2,116,490	1,371,200	281,491	3,769,181
Commercial - Add/Alter	369,191	88,000	328,000	60,363	845,554
<b>TOTAL</b>	<b>427,018</b>	<b>4,233,924</b>	<b>2,418,310</b>	<b>873,045</b>	<b>7,952,297</b>
<b>2004</b>					
Residential - New	539,297	1,777,087	1,270,100	294,860	3,881,344
Residential - Add/Alter	0	74,809	145,721	57,454	277,984
Commercial - New	4,465,026	1,366,297	21,996,101	501,601	28,329,025
Commercial - Add/Alter	60,000	530,380	368,193	3,850,000	4,808,573
<b>TOTAL</b>	<b>5,064,323</b>	<b>3,748,573</b>	<b>23,780,115</b>	<b>4,703,915</b>	<b>37,296,926</b>
<b>2005</b>					
					<b>Year to Date</b>
Residential - New	720,956	1,916,999			2,637,955
Residential - Add/Alter	261,630	141,950			403,580
Commercial - New	195,000	4,099,828			4,294,828
Commercial - Add/Alter	243,969	673,458			917,427
<b>TOTAL</b>	<b>1,421,555</b>	<b>6,832,235</b>			<b>8,253,790</b>

Table 6.13

# Soldotna Construction

<b>Soldotna Annual Permit VOLUME by Type by Quarter - 1998-2005</b>					
	1st Quarter	2nd Quarter	3rd Quarter	4th Quarter	Total
<b>1998</b>					
Residential - New	1	6	7	1	15
Residential - Add/Alter	0	6	5	5	16
Commercial - New	2	11	10	2	25
Commercial - Add/Alter	5	4	6	6	21
<b>TOTAL</b>	<b>8</b>	<b>27</b>	<b>28</b>	<b>14</b>	<b>77</b>
<b>1999</b>					
Residential - New	0	10	7	2	19
Residential - Add/Alter	4	8	4	0	16
Commercial - New	0	8	6	6	20
Commercial - Add/Alter	6	9	6	1	22
<b>TOTAL</b>	<b>10</b>	<b>35</b>	<b>23</b>	<b>9</b>	<b>77</b>
<b>2000</b>					
Residential - New	2	10	5	2	19
Residential - Add/Alter	0	9	7	3	19
Commercial - New	1	3	7	7	18
Commercial - Add/Alter	5	12	7	8	32
<b>TOTAL</b>	<b>8</b>	<b>34</b>	<b>26</b>	<b>20</b>	<b>88</b>
<b>2001</b>					
Residential - New	0	14	10	0	24
Residential Add/Alter	3	10	6	4	23
Commercial - New	3	0	7	0	10
Commercial - Add/Alter	4	13	12	7	36
<b>TOTAL</b>	<b>10</b>	<b>37</b>	<b>35</b>	<b>11</b>	<b>93</b>
<b>2002</b>					
Residential - New	1	17	5	1	24
Residential Add/Alter	2	6	10	2	20
Commercial - New	4	9	5	0	18
Commercial - Add/Alter	4	19	5	1	29
<b>TOTAL</b>	<b>11</b>	<b>51</b>	<b>25</b>	<b>4</b>	<b>91</b>
<b>2003</b>					
Residential - New	0	15	4	5	24
Residential Add/Alter	3	8	4	1	16
Commercial - New	0	6	8	2	16
Commercial - Add/Alter	3	7	3	5	18
<b>TOTAL</b>	<b>6</b>	<b>36</b>	<b>19</b>	<b>13</b>	<b>74</b>
<b>2004</b>					
Residential - New	2	9	7	1	19
Residential Add/Alter	0	8	6	3	17
Commercial - New	4	3	4	2	13
Commercial - Add/Alter	3	6	7	2	18
<b>TOTAL</b>	<b>9</b>	<b>26</b>	<b>24</b>	<b>8</b>	<b>67</b>
<b>2005</b>					
	<b>Year to Date</b>				
Residential - New	4	11			15
Residential Add/Alter	3	12			15
Commercial - New	2	9			11
Commercial - Add/Alter	7	8			15
<b>TOTAL</b>	<b>16</b>	<b>40</b>			<b>56</b>

Table 6.14



# Soldotna Cost of Food

Cost of food data is collected by the University of Alaska, Fairbanks Cooperative Extension. Each quarter the Cooperative Extension surveys up to three grocers in communities throughout the state to determine the cost of food for one week. Specific guidelines are presented to the surveyors regarding item size and sale price for 104 items. Because separation of Kenai and Soldotna data would be meaningless, data presented relates to both communities.

SOLDOTNA/KENAI										
	Jun-97	Jun-98	Jun-99	Jun-00	Jun-01	Jun-02	Jun-03	Jun-04	Jun-05	Annual Change
Sales Tax (in percent)	5.0	5.0	5.0	5.0	5.0	5.0	5.0	5.0	5.0	
Percent of Food Unavailable	0.0	0.0	0.0	1.0	0.0	0.0	1.0	0.0	0.0	
Child, 1 year	15.60	15.92	16.83	16.50	17.49	17.56	17.2	19.25	19.02	-1.2%
Child, 2 years	0.00	0.00	0.00	0.00	0.00	17.56	17.1	18.87	18.81	-0.3%
Children 3-5 years of age	17.10	17.46	18.42	18.13	17.49	19.31	19.7	20.73	20.78	0.2%
Children 6-8 years of age	22.69	23.23	24.54	24.15	25.50	25.68	26.5	27.71	27.95	0.9%
Children 9-11 years of age	25.79	26.32	27.81	27.33	28.90	29.09	30.9	31.22	31.47	0.8%
Males 12-14 years of age	29.16	29.76	31.36	30.94	32.71	32.94	33.8	35.36	35.59	0.7%
Males 15-19 years of age	30.06	30.62	32.24	31.97	33.76	33.98	35.1	36.31	36.71	1.1%
Males 20-50 years of age	29.84	30.53	31.98	31.71	33.50	33.80	35.0	36.11	36.67	1.6%
Males 51 and older	28.52	29.16	30.47	30.25	31.85	32.05	33.0	34.38	34.90	1.5%
Females 12-19 years of age	25.11	25.63	27.02	26.64	28.19	28.38	28.5	30.47	30.74	0.9%
Females 20-50 years of age	26.21	26.75	27.90	27.76	29.24	29.43	29.9	31.46	31.92	1.5%
Females 51 and older	25.39	25.89	27.10	26.98	28.54	28.64	29.6	30.61	31.04	1.4%
Family of 2, 20-50 years of age	61.66	63.05	65.90	65.40	69.00	69.56	71.4	74.33	75.45	1.5%
Family of 2, 51 years and older	59.30	60.55	63.33	62.99	66.43	66.76	68.9	71.47	72.51	1.5%
Family of 4, children 1-5 years	88.74	90.66	95.13	94.10	99.36	100.10	101.8	107.17	108.18	0.9%
Family of 4, children 6-11 years	104.52	106.83	112.23	110.94	117.13	118.00	122.3	126.50	127.99	1.2%
Electricity, 1000 kWh	111.00	120.65	120.65	102.98	111.90	118.37	123.1	100.82	131.48	30.4%
Gasoline, auto, 55 gal	76.95	76.18	74.25	90.75	98.45	87.45	97.4	116.60	128.15	9.9%
Lumber, 2X4X8'	3.76	3.22	4.10	3.38	3.68	3.40	3.0	3.43	3.30	-3.8%
Propane, 100 lb. refill	39.48	36.68		42.48	43.42	43.42	48.1	49.09	59.00	20.2%
Sewer & Water, monthly	41.29	41.29								

Table 6.16

# Soldotna Cost of Food

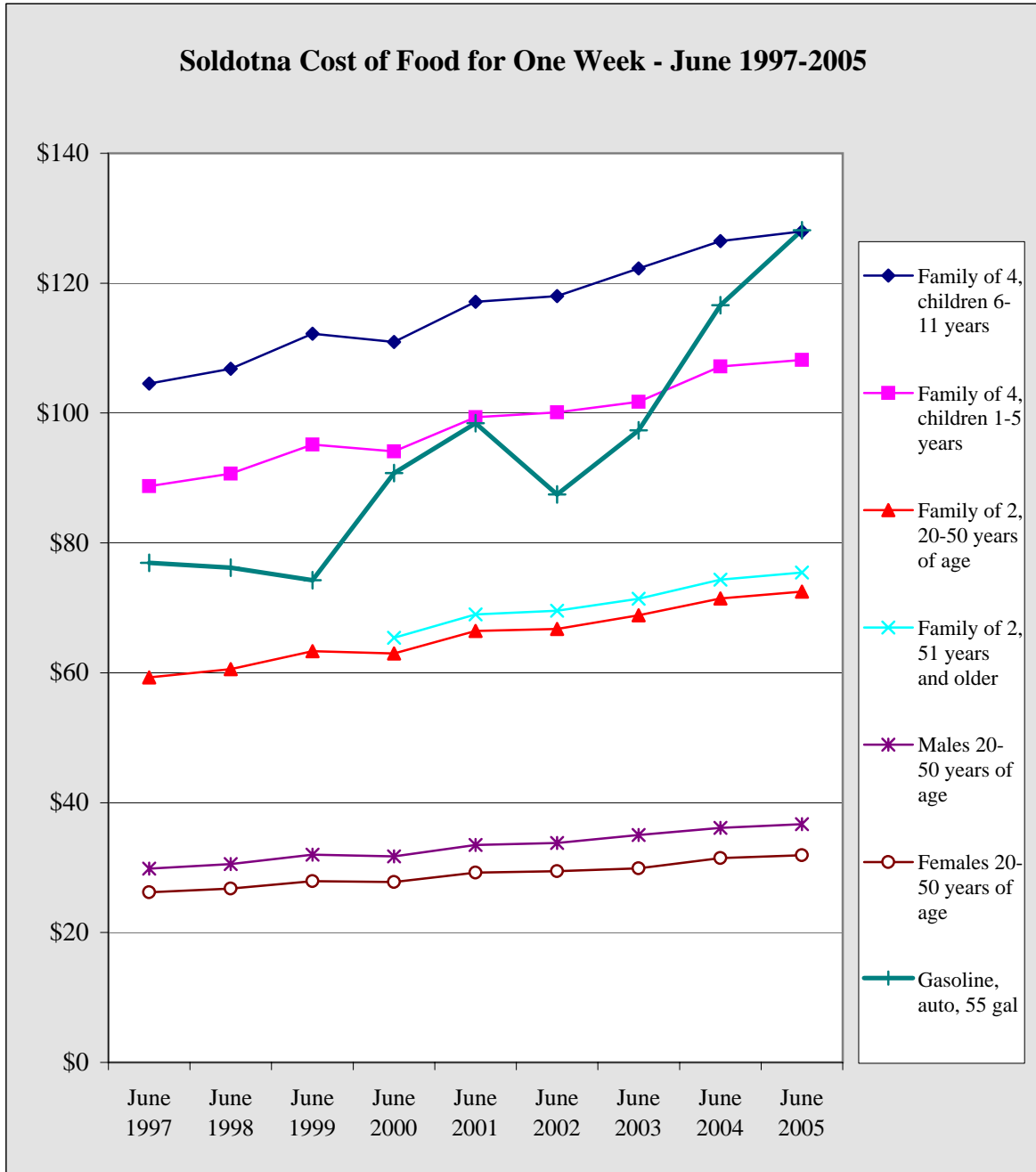

Chart 6.21

# Soldotna Population

## Soldotna Select Census Detail - 1990 v 2000

<b>Population</b>					<b>Housing</b>				
	1990	2000	Percent Change	Percent of Total		1990	2000	Percent Change	Percent of Total
Total Population	3,482	3,759	8.0%	100.0%	<b>Total Households</b>	1,284	1,465	14.1%	100.0%
Male	1,727	1,788	3.5%	47.6%	Family Households	903	970	7.4%	66.2%
Female	1,755	1,971	12.3%	52.4%	With Children Under 18	NA	577	NA	39.4%
Under 5 years	330	269	-18.5%	7.2%	Married Couple Family	674	711	5.5%	48.5%
5 to 9 years	354	331	-6.5%	8.8%	With Own Children Under 18	NA	376	NA	25.7%
10 to 14 years	306	366	19.6%	9.7%	Female Householder, no husband present	NA	201	NA	13.7%
15 to 19 years	281	331	17.8%	8.8%	With Own Children Under 18	NA	159	NA	10.9%
20 to 24 years	197	167	-15.2%	4.4%	Average Household Size	2.69	2.53	NA	0.2%
25 to 34 years	627	420	-33.0%	11.2%	Average Family Size	NA	3.13	NA	0.2%
35 to 44 years	675	629	-6.8%	16.7%	<b>Total Housing Units</b>	1,460	1,670	NA	114.0%
45 to 54 years	337	596	76.9%	15.9%	Occupied Housing Units	1,284	1,465	14.1%	100.0%
55 to 59 years	115	176	53.0%	4.7%	Vacant Housing Units	176	205	16.5%	14.0%
60 to 64 years	84	105	25.0%	2.8%	Seasonal, Recreational, Occasional Use	24	59	145.8%	4.0%
65 to 74 years	131	198	51.1%	5.3%	Owner Vacancy Rate	NA	1.9%	NA	NA
75 to 84 years	39	144	269.2%	3.8%	Rental Vacancy Rate	NA	15.4%	NA	NA
85 years and over	6	27	350.0%	0.7%	Owner Occupied Units	747	920	23.2%	62.8%
Median Age	29.5	34.9	18.3%	NA	Renter Occupied Units	537	545	1.5%	37.2%
18 Years and Over	1,181	2,475	109.6%	65.8%	<b>Marital Status (over 15)</b>	NA	2,751	NA	NA
Male		1,166	NA	31.0%	Never married	NA	618	NA	22.5%
Female		1,409	NA	37.5%	Married except separated	NA	1,505	NA	54.7%
65 Years and Over	176	369	109.7%	9.8%	Separated	NA	97	NA	3.5%
Male		126	NA	3.4%	Widowed	NA	152	NA	5.5%
Female		243	NA	6.5%	Divorced	NA	379	NA	13.8%
<b>Place of Birth</b>					<b>Disabled, Noninstitutionalized</b>				
Native Born	3,405	3,609	6.0%	96.0%	Population 5 to 20	NA	1,072	NA	100.0%
Born in Alaska	NA	1,432	NA	38.1%	With a Disability	NA	73	NA	6.8%
Born in other state	NA	2,160	NA	57.5%	Population 21 to 64	NA	2,079	NA	100.0%
Foreign Born	51	113	121.6%	3.0%	With a Disability	NA	432	NA	20.8%
Naturalized Citizen	NA	94	NA	2.5%	Percent Employed	NA	54.9%	NA	0.0%
Not a Citizen	NA	19	NA	0.5%	Without a Disability	NA	1,647	NA	79.2%
					Percent Employed	NA	77.7%	NA	0.0%
<b>Veteran Status - (over 18)</b>					<b>Income in 1999 - Families</b>				
Civilian veterans	400	396	NA	15.7%			Total		980
<b>Educational Attainment</b>					Less than \$10,000	41	34	-17.1%	3.5%
Population 25 years and over				2,249	\$10,000 - \$14,999	46	42	-8.7%	4.3%
Less than 9th grade	39	59	51.3%	2.6%	\$15,000 - \$24,999	160	104	-35.0%	10.6%
9th-12th, no diploma	116	219	88.8%	9.7%	\$25,000 - \$34,999	60	109	81.7%	11.1%
High School Diploma	730	790	8.2%	35.1%	\$35,000 - \$49,999	201	164	-18.4%	16.7%
College, no degree	555	694	25.0%	30.9%	\$50,000 - \$74,999	257	216	-16.0%	22.0%
Associate Degree	147	139	-5.4%	6.2%	\$75,000 - \$99,999	115	140	21.7%	14.3%
Bachelor's Degree	283	214	-24.4%	9.5%	\$100,000 - \$149,999	40	127	217.5%	13.0%
Graduate, Profess Degree	110	134	21.8%	6.0%	\$150,000 - \$199,999	0	18	NA	1.8%
Percent HS Grad	92.2%	87.6%	-5.0%	NA	\$200,000 or more	NA	26	NA	2.7%
Percent Bachelor's +	19.8%	15.5%	-21.7%	NA	Median Income - \$	46,667	52,372	12.2%	NA

Table 6.15

# Other KPB Sales

<b>Other KPB 2nd Quarter GROSS Sales by Industry - 1999-2005 - in \$</b>							
	1999	2000	2001	2002	2003	2004	2005
AFF	1,006,214	895,333	1,133,165	1,142,492	2,042,231	1,256,193	1,534,670
Min	25,197,119	25,208,965	25,603,580	29,103,164	24,039,296	29,692,204	32,627,706
Const	20,589,328	20,599,714	26,755,464	30,778,098	35,948,201	22,797,683	26,883,481
Manu	29,640,273	26,397,183	46,327,693	34,871,253	22,050,431	7,606,427	12,354,584
TCPU	18,812,079	15,437,379	17,129,688	18,167,731	15,634,861	16,722,028	17,782,494
Whole	23,318,497	26,003,440	25,989,525	28,469,316	29,652,374	28,462,396	18,490,308
Retail	34,927,187	37,452,274	41,399,338	40,486,870	46,326,072	45,753,591	48,491,068
FIRE	4,083,396	3,698,979	4,648,250	3,704,383	4,574,602	3,931,587	4,762,307
Service	23,135,453	28,284,250	28,661,264	28,996,481	27,700,199	30,871,120	31,050,604
Govt	0	0	0	0	0	0	0
<b>Total</b>	<b>180,709,546</b>	<b>183,977,517</b>	<b>217,647,967</b>	<b>215,719,788</b>	<b>207,968,267</b>	<b>187,093,229</b>	<b>193,977,222</b>
Annual Change		1.8%	18.3%	-0.9%	-3.6%	-10.0%	3.7%

Table 7.1

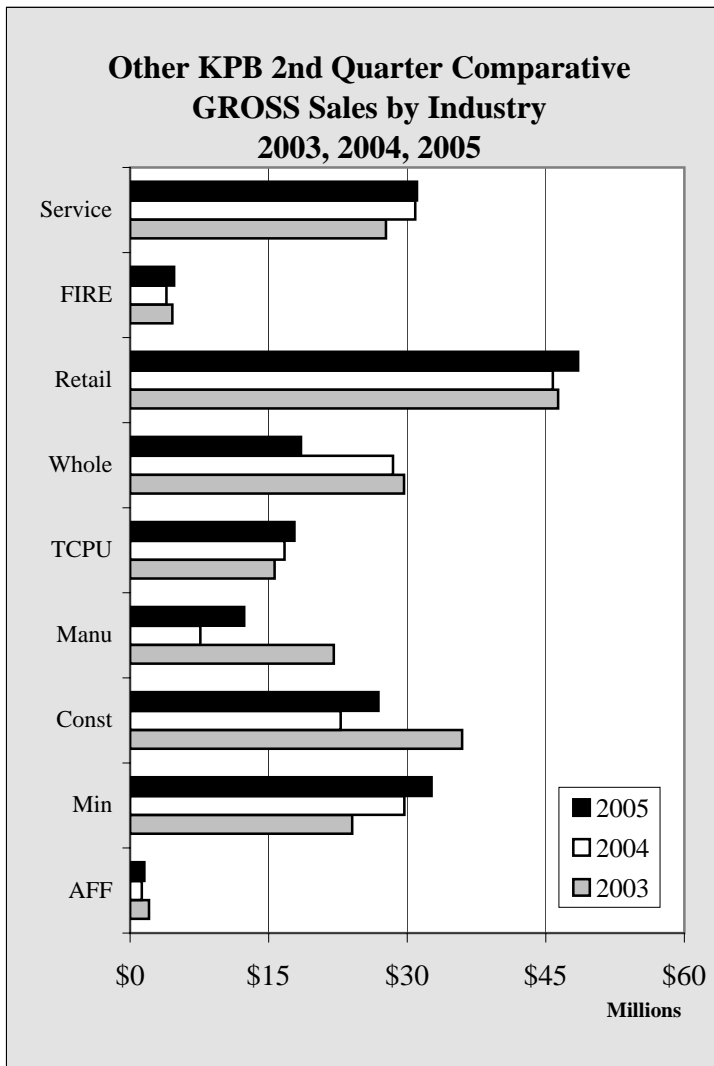

Chart 7.1

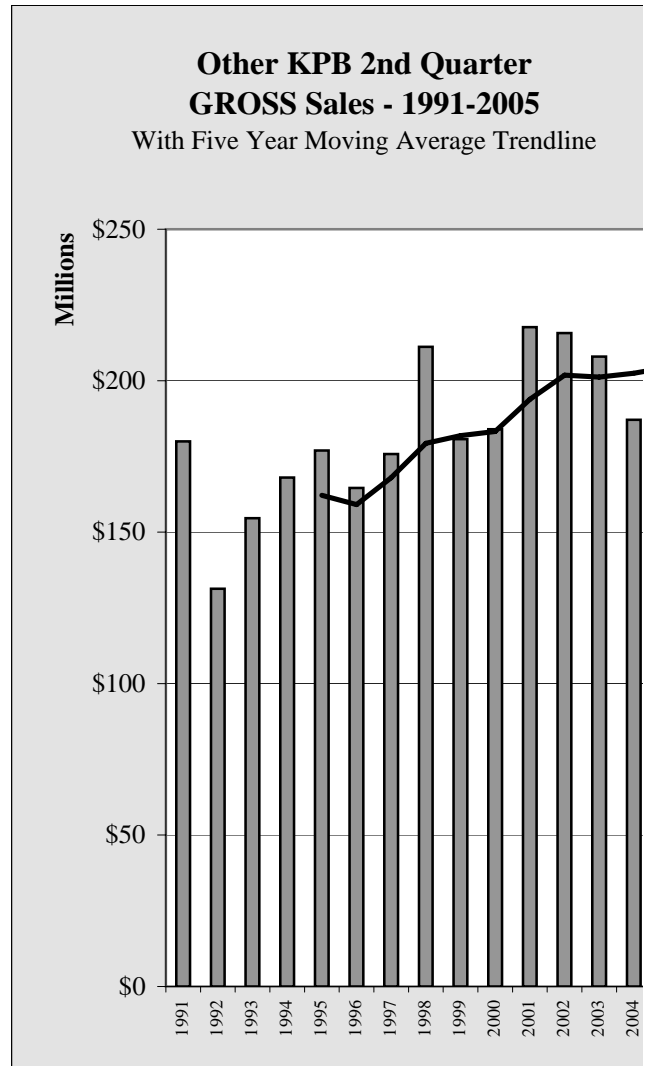
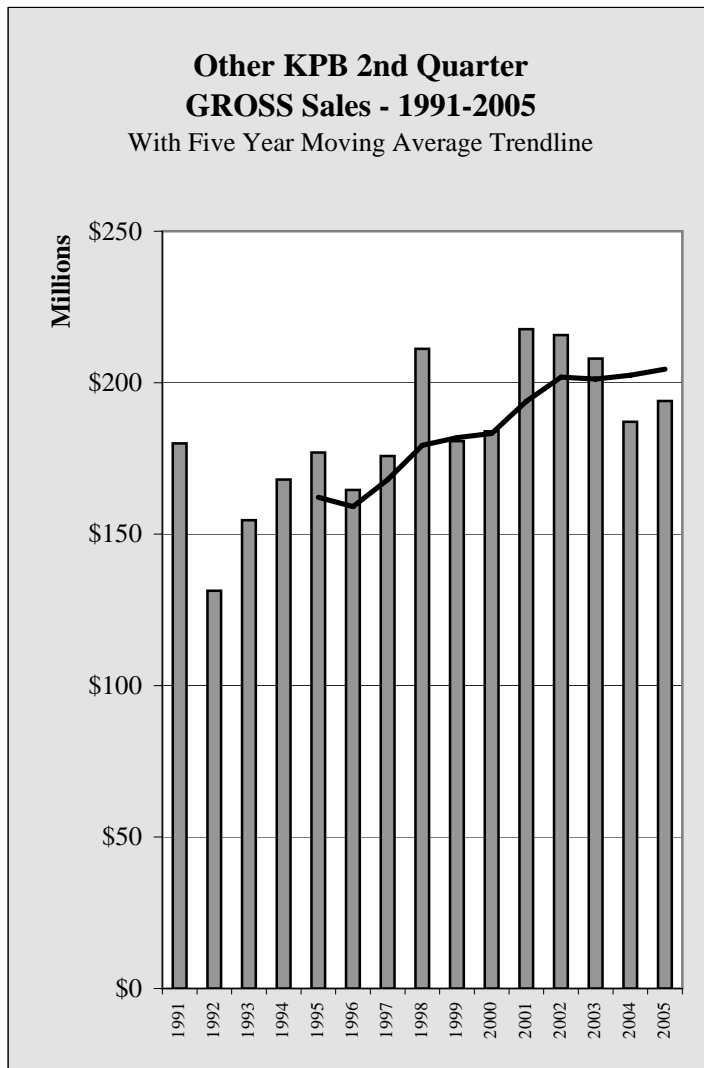

Chart 7.2

# Other KPB Sales

Annual Change
22.2%
9.9%
17.9%
62.4%
6.3%
-35.0%
6.0%
21.1%
0.6%
NA
3.7%



# Other KPB Sales

Other KPB 2nd Quarter TAXABLE Sales by Industry - 1999-2005 - in \$							
	1999	2000	2001	2002	2003	2004	2005
AFF	624,351	688,139	755,318	780,587	859,055	915,588	955,900
Min	926,985	1,046,589	1,265,086	1,417,403	1,114,615	1,018,997	973,689
Const	1,362,150	1,500,309	1,568,794	1,657,737	1,889,809	1,724,460	1,856,552
Manu	902,042	935,882	892,944	881,441	792,161	785,263	923,221
TCPU	9,207,004	9,290,261	9,844,493	11,314,077	9,184,673	8,908,793	10,277,879
Whole	2,231,807	2,624,808	2,722,910	2,743,971	2,930,861	2,862,301	2,908,019
Retail	20,784,479	22,911,114	24,014,664	23,266,764	25,345,609	24,688,643	24,578,036
FIRE	1,494,811	1,494,929	1,692,258	1,626,536	1,841,058	1,680,137	1,800,494
Service	13,212,897	14,713,026	15,114,615	13,671,993	14,212,739	15,603,491	15,832,188
Govt	0	0	0	0	0	0	0
<b>Total</b>	<b>50,746,526</b>	<b>55,205,057</b>	<b>57,871,082</b>	<b>57,360,509</b>	<b>58,170,580</b>	<b>58,187,673</b>	<b>60,105,978</b>
Annual Change		8.8%	4.8%	-0.9%	1.4%	0.0%	3.3%

Table 7.2

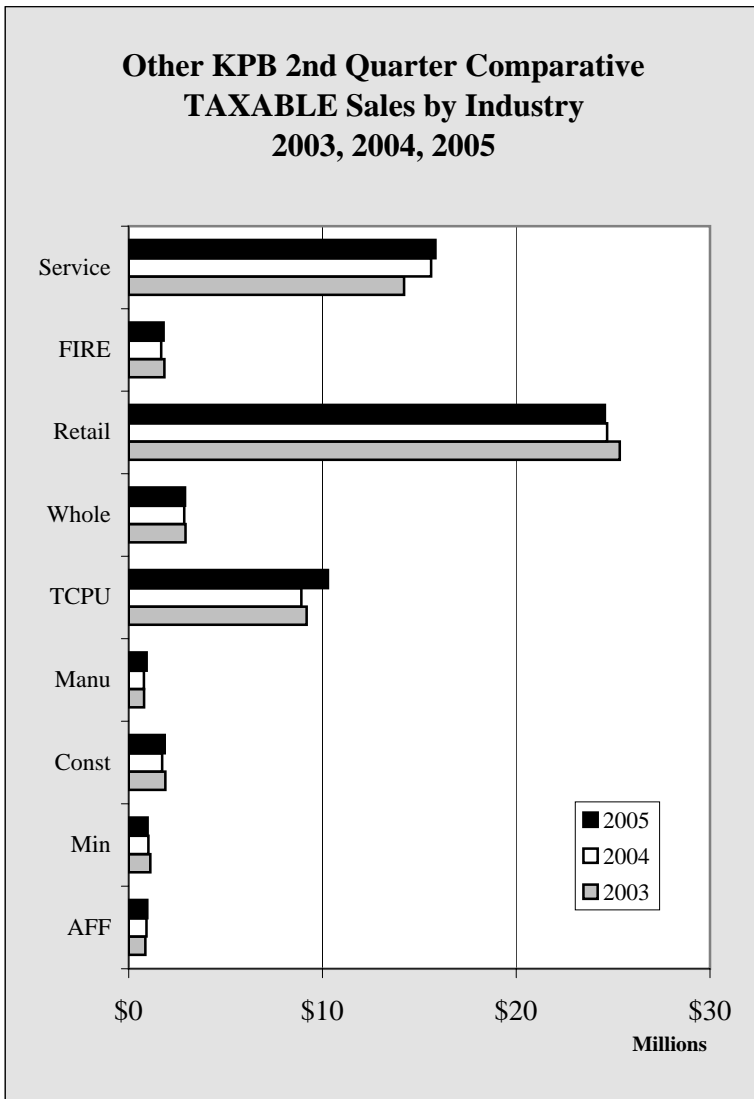

Chart 7.3

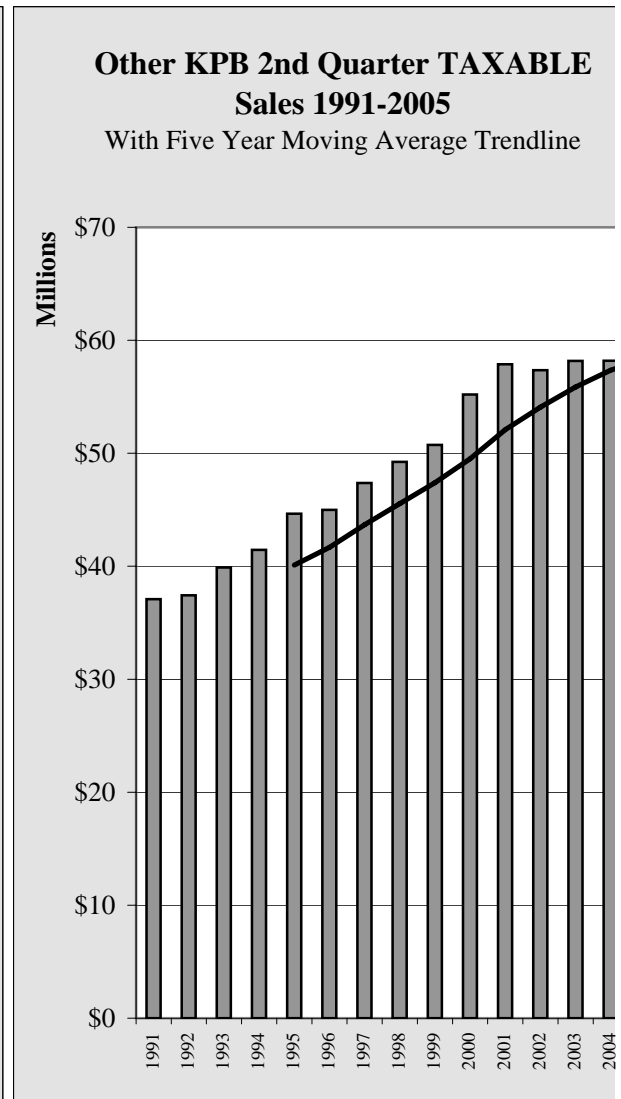
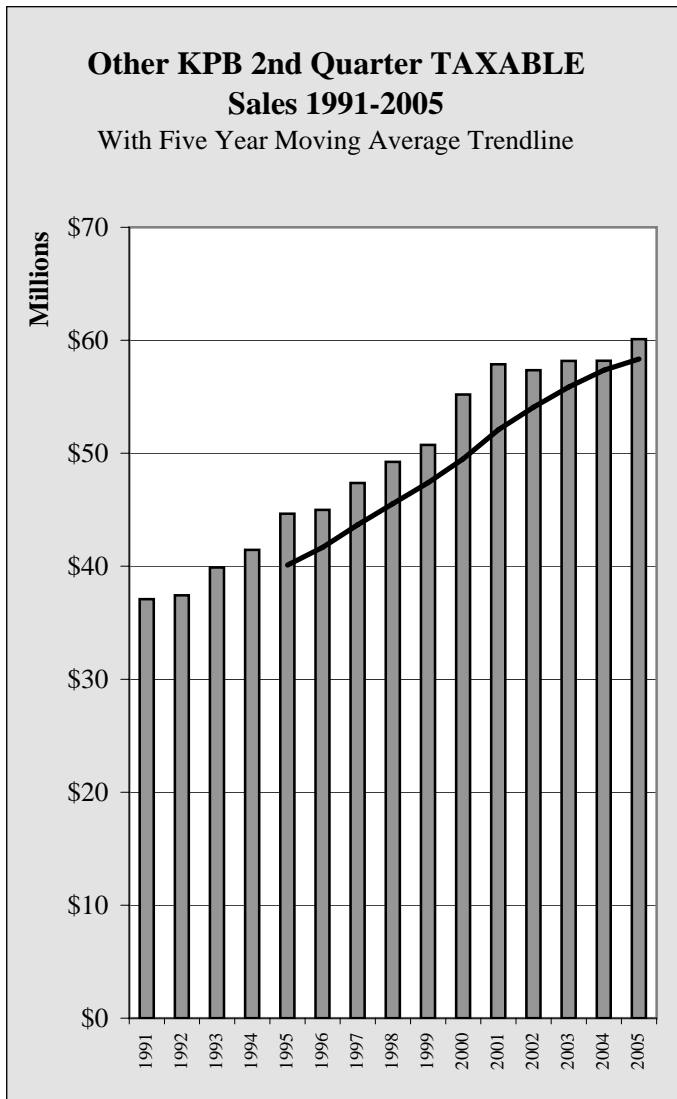

Chart 7.4

# Other KPB Sales

Annual Change
4.4%
-4.4%
7.7%
17.6%
15.4%
1.6%
-0.4%
7.2%
1.5%
NA
3.3%



# Other KPB Sales

<b>Other KPB YTD 6/30 GROSS Sales by Industry - 1999-2005 - in \$</b>							
	1999	2000	2001	2002	2003	2004	2005
AFF	1,358,425	1,247,615	1,678,643	1,590,143	2,487,316	1,694,447	2,013,634
Min	59,647,978	43,489,424	52,852,431	61,402,416	42,178,318	67,364,432	70,093,008
Const	31,104,194	32,747,954	48,462,080	55,384,048	57,972,494	37,935,026	48,786,758
Manu	49,144,018	46,359,763	87,384,091	49,825,823	53,712,724	29,549,699	42,252,159
TCPU	36,812,851	31,124,269	33,850,617	36,588,703	30,232,931	31,681,467	36,685,098
Whole	41,106,850	45,620,628	46,261,644	50,412,457	50,600,896	50,494,264	43,645,976
Retail	57,085,718	63,440,415	68,572,844	69,239,003	77,099,916	75,797,556	78,860,721
FIRE	7,230,938	6,737,912	7,916,561	6,919,245	7,376,114	7,671,375	8,017,772
Service	34,665,546	39,874,518	41,219,266	43,738,911	40,671,355	44,069,114	46,032,294
Govt	0	0	0	0	0	6,365	13,317
<b>Total</b>	<b>318,156,518</b>	<b>310,642,498</b>	<b>388,198,177</b>	<b>375,100,749</b>	<b>362,332,064</b>	<b>346,263,745</b>	<b>376,400,737</b>
Annual Change		-2.4%	25.0%	-3.4%	-3.4%	-4.4%	8.7%

Table 7.3

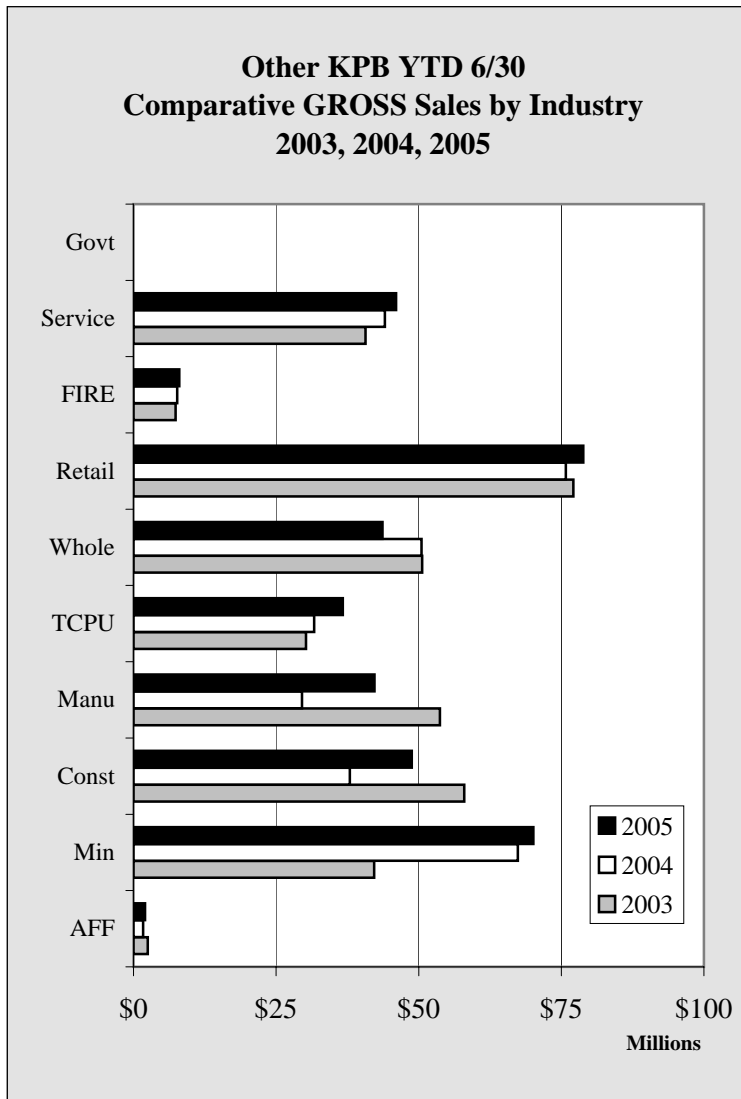

Chart 7.5

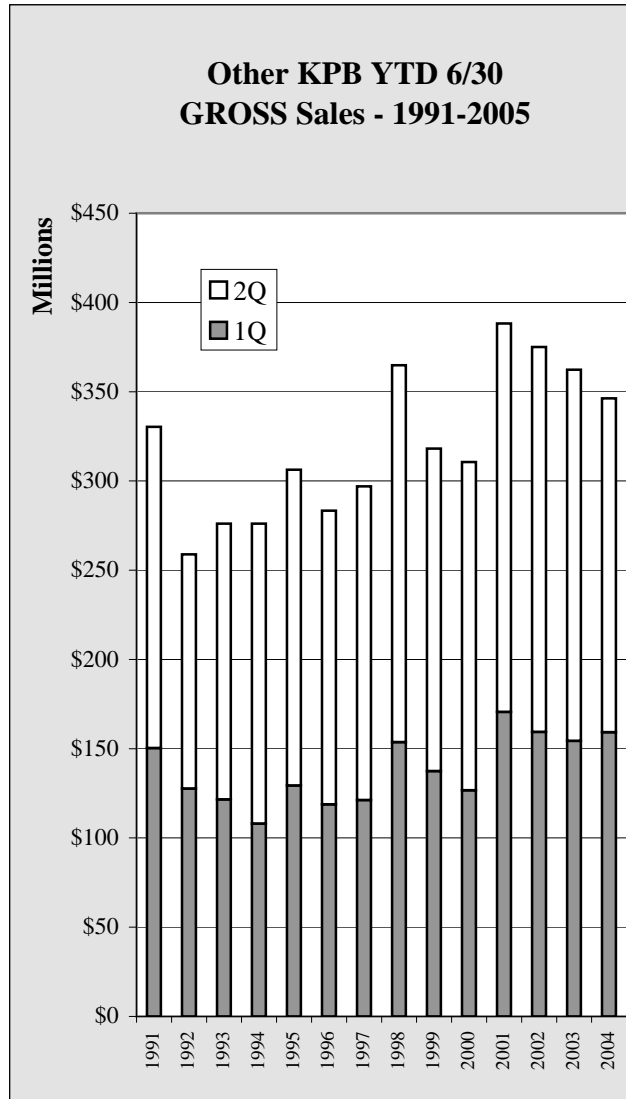
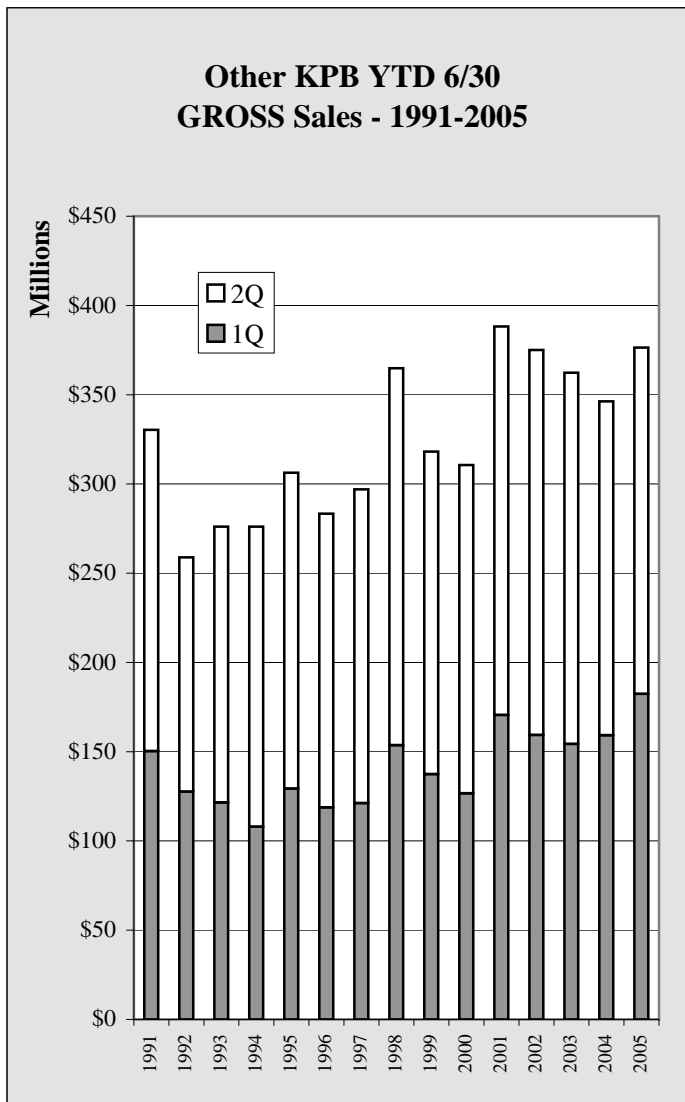

Chart 7.6



# Other KPB Sales

Annual Change
18.8%
4.1%
28.6%
43.0%
15.8%
-13.6%
4.0%
4.5%
4.5%
109.2%
8.7%



# Other KPB Sales

<b>Other KPB YTD 6/30 TAXABLE Sales by Industry - 1999-2005 - in \$</b>							
	1999	2000	2001	2002	2003	2004	2005
AFF	875,083	984,247	1,099,152	1,177,104	1,219,206	1,318,479	1,383,478
Min	1,683,259	1,916,427	2,424,873	2,841,477	2,304,740	1,996,163	1,985,156
Const	2,378,252	2,446,830	2,647,523	2,789,792	3,034,248	2,904,620	2,998,777
Manu	1,291,165	1,283,455	1,301,057	1,278,092	1,147,304	1,153,164	1,321,318
TCPU	19,411,130	19,195,294	20,282,481	23,454,900	19,101,385	19,167,428	22,641,095
Whole	4,414,317	5,137,992	5,303,572	5,609,365	5,704,576	6,190,487	6,122,164
Retail	34,105,699	37,384,584	39,284,302	39,575,919	41,482,432	40,786,875	40,477,500
FIRE	2,779,459	2,725,611	3,020,218	3,133,212	3,293,835	3,161,439	3,209,198
Service	18,156,630	19,826,978	20,563,163	19,305,532	19,268,527	20,583,905	21,001,759
Govt	0	0	0	0	0	6,300	13,317
<b>Total</b>	<b>85,094,994</b>	<b>90,901,418</b>	<b>95,926,341</b>	<b>99,165,393</b>	<b>96,556,253</b>	<b>97,268,860</b>	<b>101,153,762</b>
Annual Change		6.8%	5.5%	3.4%	-2.6%	0.7%	4.0%

Table 7.4

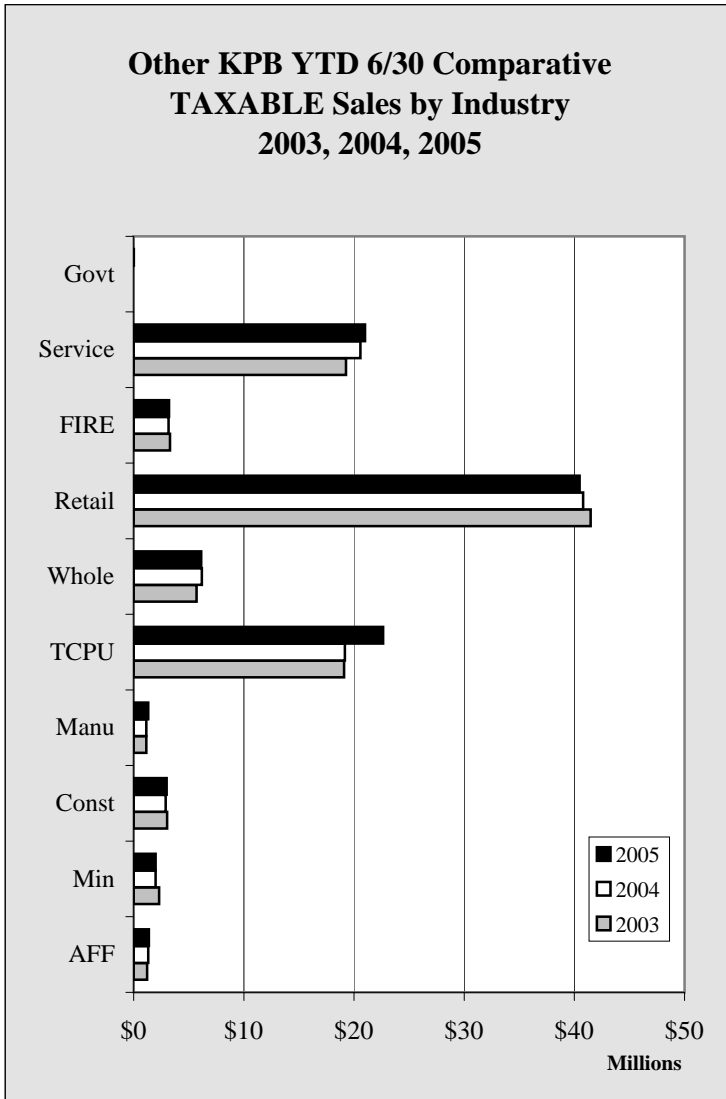

Chart 7.7

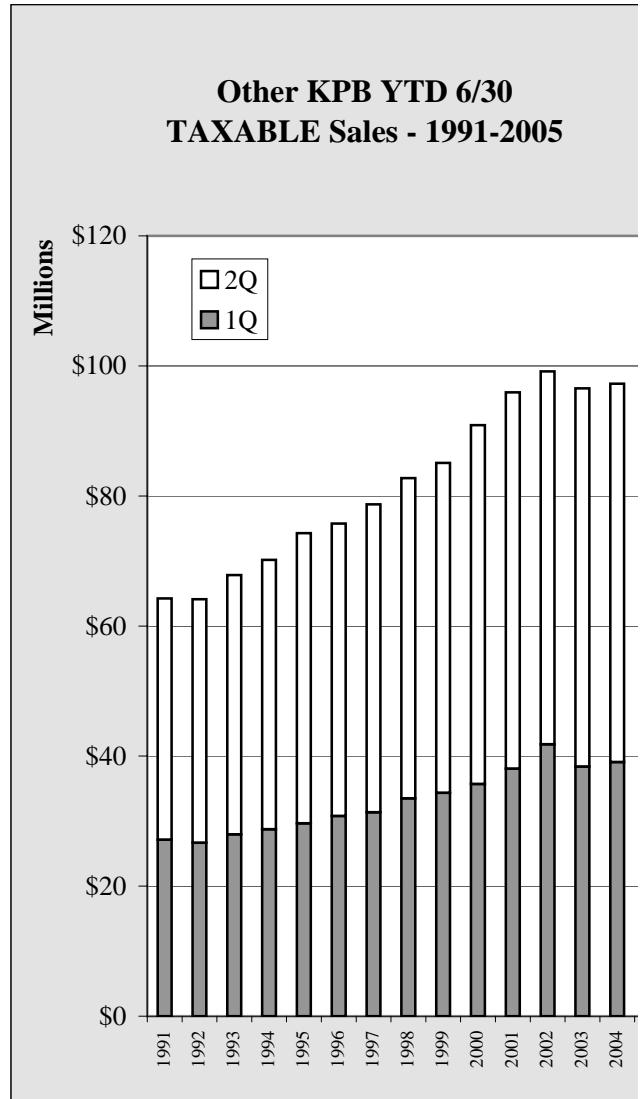
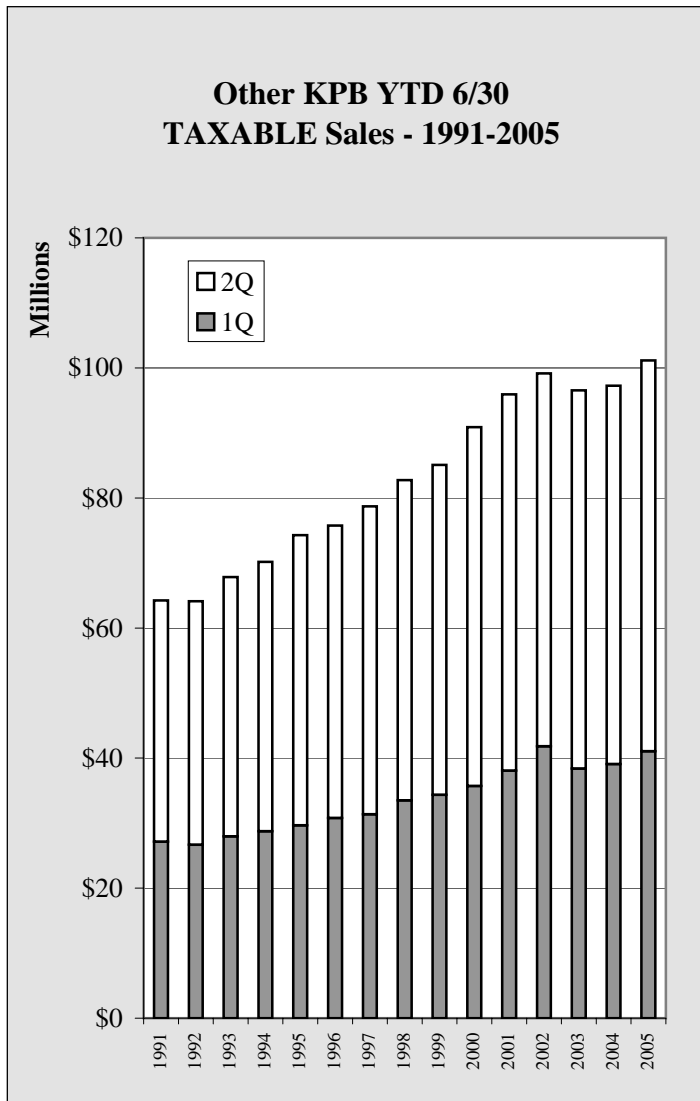

Chart 7.8

# Other KPB Sales

Annual Change
4.9%
-0.6%
3.2%
14.6%
18.1%
-1.1%
-0.8%
1.5%
2.0%
NA
4.0%



# Other KPB Sales

Other KPB Annual GROSS Sales by Industry - 1998-2004 - in \$								
	1998	1999	2000	2001	2002	2003	2004	Annual Change
AFF	6,119,386	2,812,823	2,875,629	3,242,403	4,090,590	4,814,409	5,857,634	21.7%
Min	187,521,559	113,163,554	115,625,431	123,091,789	108,808,400	101,004,267	155,698,225	54.2%
Const	88,142,507	87,808,495	88,853,048	136,499,774	131,261,695	133,897,211	130,447,251	-2.6%
Manu	112,671,455	132,512,994	85,638,574	250,593,511	164,076,655	159,471,272	143,967,105	-9.7%
TCPU	73,567,609	78,647,818	66,837,538	77,388,092	73,138,015	63,786,231	78,102,991	22.4%
Whole	101,466,620	91,041,042	101,310,365	104,710,505	108,334,825	115,986,698	118,995,491	2.6%
Retail	128,963,750	128,644,968	138,967,225	153,029,767	155,130,975	166,755,991	167,903,671	0.7%
FIRE	15,909,441	15,194,140	13,106,195	15,680,221	14,436,076	16,408,311	19,329,577	17.8%
Service	78,651,481	83,322,595	95,090,680	100,412,737	102,659,177	98,547,914	113,364,085	15.0%
Govt	6,585	0	0	0	0	0	13,732	NA
Total	793,020,393	733,148,429	708,304,685	964,648,799	861,936,408	860,672,304	933,679,762	8.5%
Annual Change		-7.5%	-3.4%	36.2%	-10.6%	-0.1%	8.5%	

Table 7.5

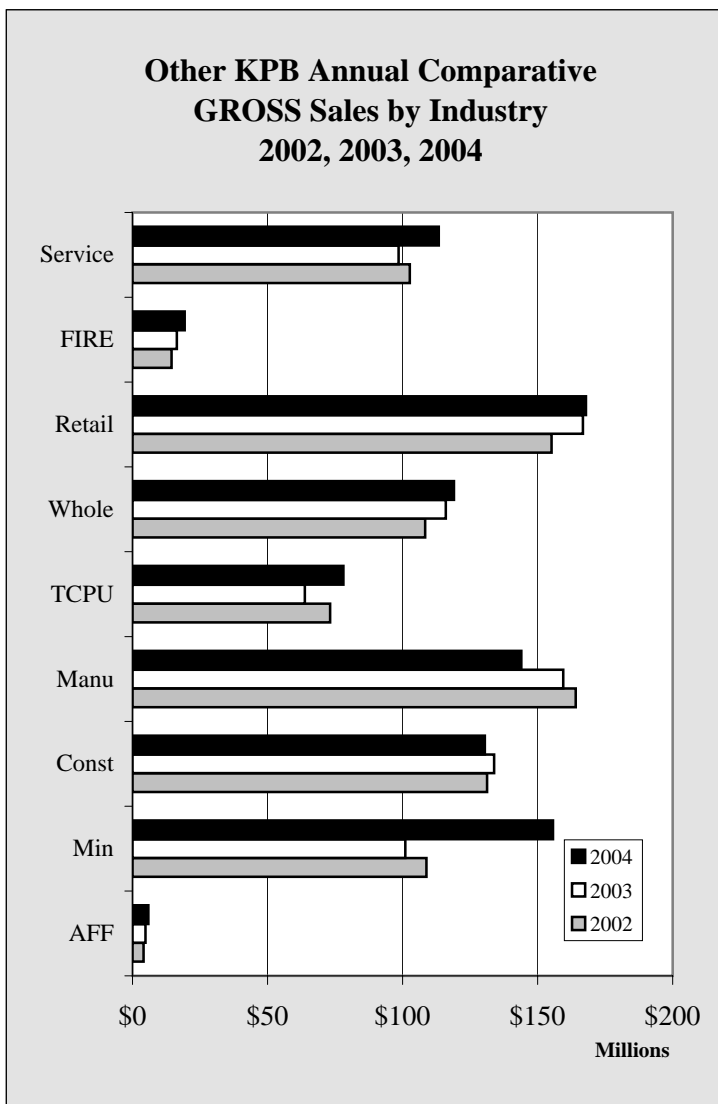

Chart 7.9

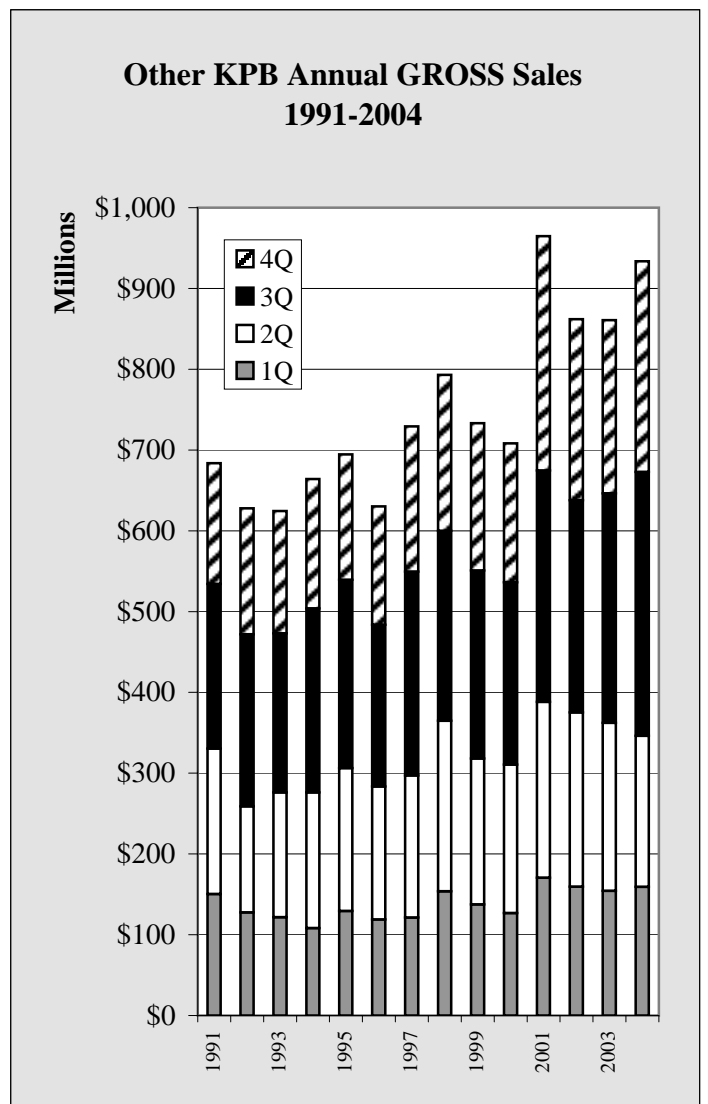

Chart 7.10

# Other KPB Sales

Other KPB Annual TAXABLE Sales by Industry - 1998-2004 - in \$							
	1998	1999	2000	2001	2002	2003	2004
AFF	1,722,929	1,738,057	1,945,844	2,016,782	2,152,460	2,281,300	2,540,907
Min	5,144,815	3,724,685	4,434,095	5,598,954	5,598,990	4,655,675	5,218,907
Const	5,738,513	5,621,785	5,735,340	6,115,447	6,566,858	6,601,200	6,758,897
Manu	3,388,424	3,021,658	3,084,591	3,041,030	2,944,959	2,626,320	2,872,294
TCPU	35,992,074	39,160,283	39,092,526	42,147,135	41,606,993	37,098,365	40,099,801
Whole	8,733,322	9,868,388	11,100,421	11,675,046	11,425,901	12,058,985	12,951,451
Retail	72,533,481	75,119,590	80,838,970	85,853,411	86,150,313	89,695,084	88,943,810
FIRE	5,494,477	5,585,421	5,678,461	6,363,047	6,509,160	7,017,830	6,664,257
Service	40,794,714	43,554,212	47,432,032	48,734,123	47,390,646	47,504,072	52,126,452
Govt	6,585	0	0	0	0	0	13,667
Total	179,549,334	187,394,079	199,342,280	211,544,975	210,346,280	209,538,831	218,190,443
Annual Change		4.4%	6.4%	6.1%	-0.6%	-0.4%	4.1%

Table 7.6

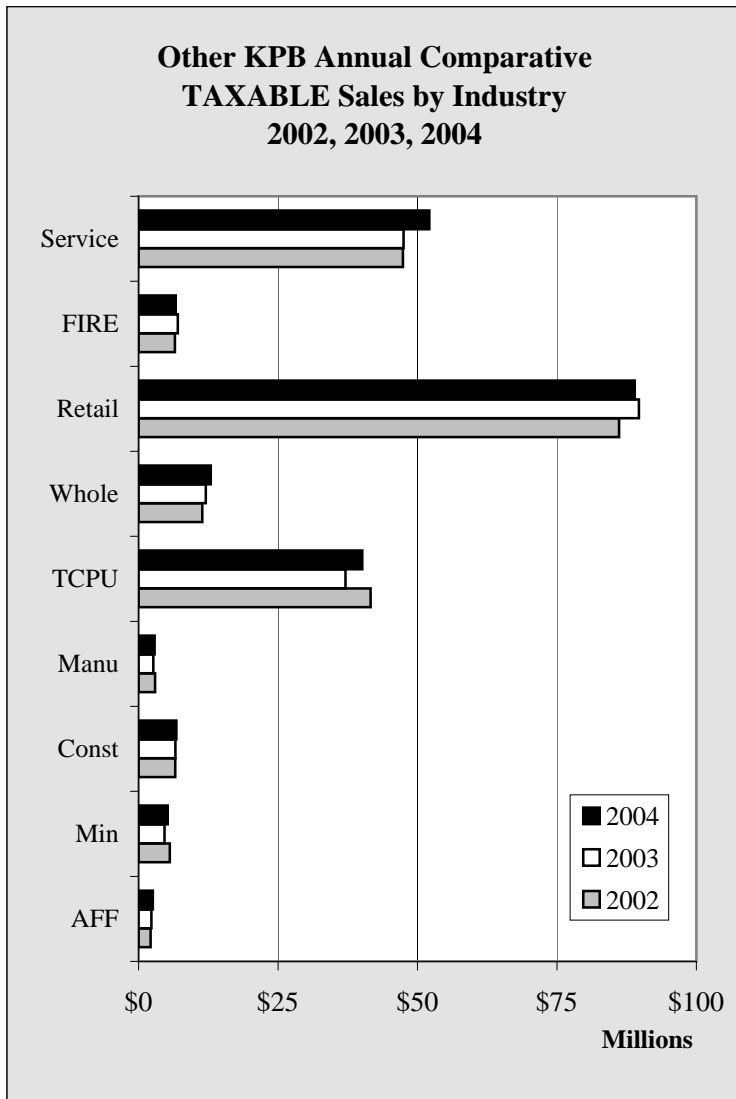

Chart 7.11

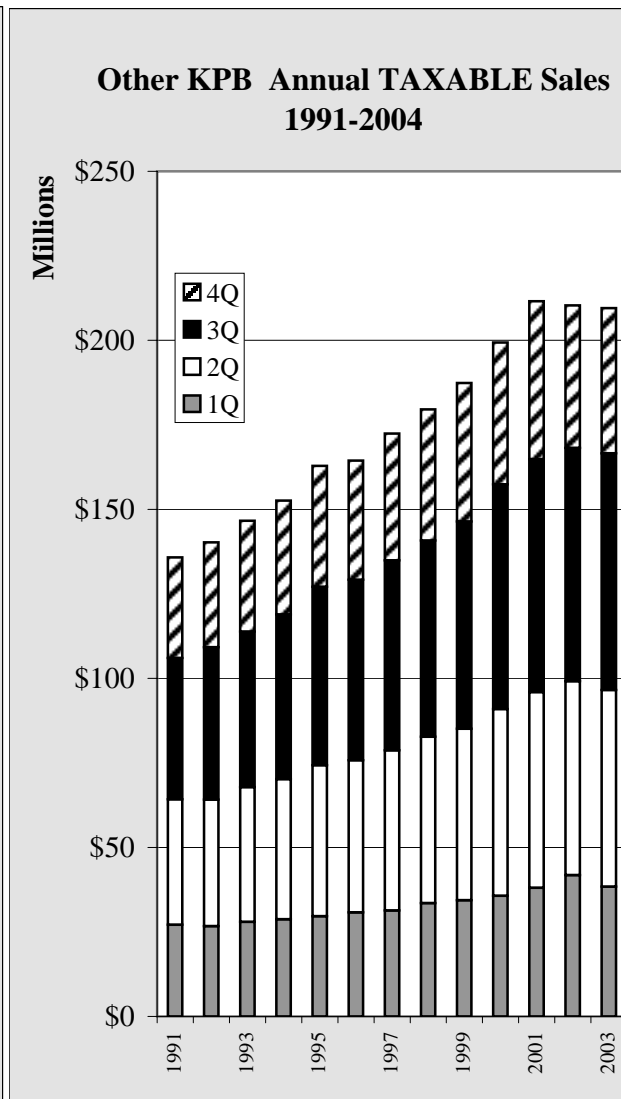
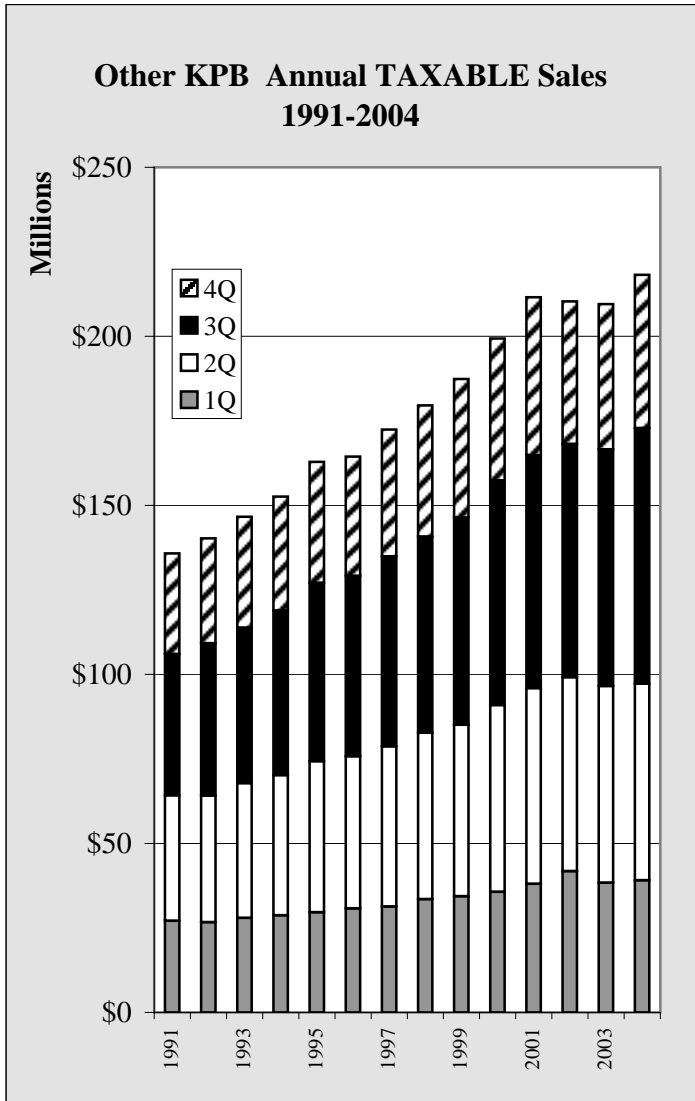

Chart 7.12

# Other KPB Sales

Annual Change
11.4%
12.1%
2.4%
9.4%
8.1%
7.4%
-0.8%
-5.0%
9.7%
NA
4.1%



# Other KPB Sales

<b>Other KPB GROSS Sales by Industry by Quarter - 2002-2005 - in \$</b>					
	1st Quarter	2nd Quarter	3rd Quarter	4th Quarter	Total
<b>2002</b>					
Ag, Forest, Fish	447,651	1,142,492	1,430,097	1,070,350	4,090,590
Mining	32,299,252	29,103,164	25,287,979	22,118,005	108,808,400
Construction	24,605,950	30,778,098	40,528,297	35,349,350	131,261,695
Manufacturing	14,954,570	34,871,253	44,941,727	69,309,105	164,076,655
Trans, Comm, Public Utility	18,420,972	18,167,731	21,630,289	14,919,023	73,138,015
Wholesale	21,943,141	28,469,316	31,837,444	26,084,924	108,334,825
Retail	28,752,133	40,486,870	50,013,715	35,878,257	155,130,975
Finance, Ins, Real Estate	3,214,862	3,704,383	3,878,053	3,638,778	14,436,076
Services	14,742,430	28,996,481	43,193,240	15,727,026	102,659,177
Government	0	0	0	0	0
<b>Total</b>	<b>159,380,961</b>	<b>215,719,788</b>	<b>262,740,841</b>	<b>224,094,818</b>	<b>861,936,408</b>
<b>2003</b>					
Ag, Forest, Fish	445,085	2,042,231	1,578,920	748,173	4,814,409
Mining	18,139,022	24,039,296	28,701,184	30,124,765	101,004,267
Construction	22,024,293	35,948,201	44,783,625	31,141,092	133,897,211
Manufacturing	31,662,293	22,050,431	53,343,537	52,415,011	159,471,272
Trans, Comm, Public Utility	14,598,070	15,634,861	18,568,068	14,985,232	63,786,231
Wholesale	20,948,522	29,652,374	37,077,443	28,308,359	115,986,698
Retail	30,773,844	46,326,072	52,432,838	37,223,237	166,755,991
Finance, Ins, Real Estate	2,801,512	4,574,602	5,140,046	3,892,151	16,408,311
Services	12,971,156	27,700,199	42,294,496	15,582,063	98,547,914
Government	0	0	0	0	0
<b>Total</b>	<b>154,363,797</b>	<b>207,968,267</b>	<b>283,920,157</b>	<b>214,420,083</b>	<b>860,672,304</b>
<b>2004</b>					
Ag, Forest, Fish	438,254	1,256,193	1,632,207	2,530,980	5,857,634
Mining	37,672,228	29,692,204	36,588,670	51,745,123	155,698,225
Construction	15,137,343	22,797,683	37,227,413	55,284,812	130,447,251
Manufacturing	21,943,272	7,606,427	87,311,541	27,105,865	143,967,105
Trans, Comm, Public Utility	14,959,439	16,722,028	20,217,590	26,203,934	78,102,991
Wholesale	22,031,868	28,462,396	36,327,578	32,173,649	118,995,491
Retail	30,043,965	45,753,591	54,364,065	37,742,050	167,903,671
Finance, Ins, Real Estate	3,739,788	3,931,587	4,831,335	6,826,867	19,329,577
Services	13,197,994	30,871,120	48,090,916	21,204,055	113,364,085
Government	6,365	0	6,304	1,063	13,732
<b>Total</b>	<b>159,170,516</b>	<b>187,093,229</b>	<b>326,597,619</b>	<b>260,818,398</b>	<b>933,679,762</b>
<b>2005</b>					
	<b>Year to Date</b>				
Ag, Forest, Fish	478,964	1,534,670			2,013,634
Mining	37,465,302	32,627,706			70,093,008
Construction	21,903,277	26,883,481			48,786,758
Manufacturing	29,897,575	12,354,584			42,252,159
Trans, Comm, Public Utility	18,902,604	17,782,494			36,685,098
Wholesale	25,155,668	18,490,308			43,645,976
Retail	30,369,653	48,491,068			78,860,721
Finance, Ins, Real Estate	3,255,465	4,762,307			8,017,772
Services	14,981,690	31,050,604			46,032,294
Government	13,317	0			13,317
<b>Total</b>	<b>182,423,515</b>	<b>193,977,222</b>			<b>376,400,737</b>

Table 7.7

# Other KPB Sales

<b>Other KPB TAXABLE Sales by Industry by Quarter - 2002-2005 - in \$</b>					
	1st Quarter	2nd Quarter	3rd Quarter	4th Quarter	Total
<b>2002</b>					
Ag, Forest, Fish	396,517	780,587	570,742	404,614	2,152,460
Mining	1,424,074	1,417,403	1,489,849	1,267,664	5,598,990
Construction	1,132,055	1,657,737	2,141,282	1,635,784	6,566,858
Manufacturing	396,651	881,441	1,202,450	464,417	2,944,959
Trans, Comm, Public Utility	12,140,823	11,314,077	9,075,340	9,076,753	41,606,993
Wholesale	2,865,394	2,743,971	2,958,254	2,858,282	11,425,901
Retail	16,309,155	23,266,764	27,810,124	18,764,270	86,150,313
Finance, Ins, Real Estate	1,506,676	1,626,536	1,941,804	1,434,144	6,509,160
Services	5,633,539	13,671,993	21,829,387	6,255,727	47,390,646
Government	0	0	0	0	0
<b>Total</b>	<b>41,804,884</b>	<b>57,360,509</b>	<b>69,019,232</b>	<b>42,161,655</b>	<b>210,346,280</b>
<b>2003</b>					
Ag, Forest, Fish	360,151	859,055	635,120	426,974	2,281,300
Mining	1,190,125	1,114,615	1,252,874	1,098,061	4,655,675
Construction	1,144,439	1,889,809	2,022,587	1,544,365	6,601,200
Manufacturing	355,143	792,161	968,694	510,322	2,626,320
Trans, Comm, Public Utility	9,916,712	9,184,673	8,687,138	9,309,842	37,098,365
Wholesale	2,773,715	2,930,861	3,197,783	3,156,626	12,058,985
Retail	16,136,823	25,345,609	28,911,497	19,301,155	89,695,084
Finance, Ins, Real Estate	1,452,777	1,841,058	2,240,741	1,483,254	7,017,830
Services	5,055,788	14,212,739	22,072,245	6,163,300	47,504,072
Government	0	0	0	0	0
<b>Total</b>	<b>38,385,673</b>	<b>58,170,580</b>	<b>69,988,679</b>	<b>42,993,899</b>	<b>209,538,831</b>
<b>2004</b>					
Ag, Forest, Fish	402,891	915,588	748,068	474,360	2,540,907
Mining	977,166	1,018,997	1,829,645	1,393,099	5,218,907
Construction	1,180,160	1,724,460	2,106,631	1,747,646	6,758,897
Manufacturing	367,901	785,263	1,215,828	503,302	2,872,294
Trans, Comm, Public Utility	10,258,635	8,908,793	10,037,127	10,895,246	40,099,801
Wholesale	3,328,186	2,862,301	3,238,122	3,522,842	12,951,451
Retail	16,098,232	24,688,643	29,328,205	18,828,730	88,943,810
Finance, Ins, Real Estate	1,481,302	1,680,137	1,946,397	1,556,421	6,664,257
Services	4,980,414	15,603,491	25,111,082	6,431,465	52,126,452
Government	6,300	0	6,304	1,063	13,667
<b>Total</b>	<b>39,081,187</b>	<b>58,187,673</b>	<b>75,567,409</b>	<b>45,354,174</b>	<b>218,190,443</b>
<b>2005</b>					
				<b>Year to Date</b>	
Ag, Forest, Fish	427,578	955,900			1,383,478
Mining	1,011,467	973,689			1,985,156
Construction	1,142,225	1,856,552			2,998,777
Manufacturing	398,097	923,221			1,321,318
Trans, Comm, Public Utility	12,363,216	10,277,879			22,641,095
Wholesale	3,214,145	2,908,019			6,122,164
Retail	15,899,464	24,578,036			40,477,500
Finance, Ins, Real Estate	1,408,704	1,800,494			3,209,198
Services	5,169,571	15,832,188			21,001,759
Government	13,317	0			13,317
<b>Total</b>	<b>41,047,784</b>	<b>60,105,978</b>			<b>101,153,762</b>

Table 7.8



# KPB Local Officials Directory

Officials of the various governing bodies within the Kenai Peninsula Borough are listed on the following pages.

The officials listed are those who held office at the time of printing of the report. Annual elections for public officials are held each October. For information regarding current public officials, check the appropriate website.

Kenai Peninsula Borough – <http://www.borough.kenai.ak.us/>

Kenai Peninsula Borough School District – <http://www.kpbsd.k12.ak.us/>

City of Homer – <http://www.ci.homer.ak.us/>

City of Kenai – <http://www.ci.kenai.ak.us/>

City of Seldovia – <http://www.xyz.net/~seldovia/>

City of Seward – <http://www.cityofseward.net/>

City of Soldotna – <http://www.ci.soldotna.ak.us/>

# KPB Local Officials Directory

## Kenai Peninsula Borough Mayors

### Kenai Peninsula Borough

Mayor Dale Bagley  
144 North Binkley  
Soldotna, AK 99669  
907-262-4441

---

### City of Homer

Mayor Jim Hornady  
491 East Pioneer Ave.  
Homer, AK 99603  
907-235-8121

### City of Kachemak

Mayor Philemon Morris  
PO Box 598  
Homer, AK 99603  
907-235-8897

### City of Kenai

Mayor Pat Porter  
210 Fidalgo Street, Suite 200  
Kenai, AK 99611  
907-283-7535

### City of Seldovia

Mayor Dick Wyland  
Drawer B  
Seldovia, AK 99663  
907-234-7643

### City of Seward

Mayor Vanta Shafer  
PO Box 167  
Seward, AK 99664  
907-224-4046

### City of Soldotna

Mayor Dave Carey  
177 North Birch  
Soldotna, AK 99669  
907-262-9107

Table 8.1

# KPB Local Officials Directory

## Kenai Peninsula Borough Mayor & Assembly

144 N. Binkley - Soldotna, Alaska 99669

Phone 907-262-4441

Administration Fax: 907-262-1892 - Assembly/Clerk Fax: 907-262-8615

Assembly e-mail: [assemblyclerk@borough.kenai.ak.us](mailto:assemblyclerk@borough.kenai.ak.us)

Office/District	Name/Address	Phone/Fax/e-mail	Term Expires	Previously Elected
Borough Mayor	Dale Bagley 144 N. Binkley Soldotna, AK 99669	714-2150 W 262-3160 H 262-8616 Fax <a href="mailto:dbagley@borough.kenai.ak.us">dbagley@borough.kenai.ak.us</a>	2005	1999, 2002
Assembly 1 - Kalifornsky	Dan Chay 37306 Cetacea Lane Kenai, AK 99611	283-9227 H 283-7588 Fax <a href="mailto:chay@alaska.com">chay@alaska.com</a>	2006	2003
Assembly 2 - Kenai	Betty Glick POB 528 Kenai, AK 99611-8823	283-7644 H <a href="mailto:bjg@alaska.net">bjg@alaska.net</a>	2005	2002
Assembly 3 - Nikiski	Gary Superman - President POB 8425 Nikiski, AK 99635	776-8448 H 776-8098 Fax <a href="mailto:gsuperman@gci.net">gsuperman@gci.net</a>	2007	2001, 2004
Assembly 4 - Soldotna	Pete Sprague 188 Farnsworth Blvd. Soldotna, AK 99669	262-4073 H 262-4073 Fax <a href="mailto:psprague@alaska.net">psprague@alaska.net</a>	2007	1998, 2001, 2002
Assembly 5 - Sterling/ Funny River	Grace Merkes P.O. Box 8 Sterling, AK 99672	262-9811 H <a href="mailto:merkes@ptialaska.net">merkes@ptialaska.net</a>	2005	1991, 1992, 1993, 1996, 1999, 2002
Assembly 6 - East Peninsula	Ron Long - Vice President P.O. Box 2464 Seward, AK 99664	224-7068 H 224-5707 Fax <a href="mailto:rlms@ptialaska.net">rlms@ptialaska.net</a>	2006	2000, 2003
Assembly 7 - Central	Paul Fischer P.O. Box 889 Kasilof, AK 99610	262-9269 H 262-4902 Fax <a href="mailto:akfischer@alaska.com">akfischer@alaska.com</a>	2007	1998, 2001, 2002, 2004
Assembly 8 - Homer	Chris Moss P.O. Box 115 Homer, Alaska 99603	235-8053 H 235-8053 Fax <a href="mailto:cmoss@xyz.net">cmoss@xyz.net</a>	2005	1999, 2002
Assembly 9 - South Peninsula	Milli Martin PO Box 2652. Homer, AK 99603	235-6652 H 235-6652 Fax <a href="mailto:millimom@xyz.net">millimom@xyz.net</a>	2006	2000, 2002, 2003
Borough Attorney	Colette Thompson 144 N. Binkley Soldotna, AK 99669	714-2120 262-8686 Fax		
Borough Clerk	Sherry Biggs 144 N. Binkley Soldotna, AK 99669	714-2161 262-8615 Fax <a href="mailto:assemblyclerk@borough.kenai.ak.us">assemblyclerk@borough.kenai.ak.us</a>		

Table 8.2

# KPB Local Officials Directory

<b>KENAI PENINSULA BOROUGH</b>		
<b>PLANNING COMMISSION MEMBERS</b>		
<b>2005</b>		
<b>Member</b>	<b>Contact Information</b>	<b>Term Expires</b>
<b>CHAIRMAN</b>		
Philip Bryson P.O. Box 1041 Kenai, Alaska 99611-1041	283-4672 work 283-4428 home	Kenai City Term Expires July 31, 2007
<b>VICE CHAIRMAN</b>		
Tom Clark P.O. Box 962 Anchor Point, Alaska 99556-0962	235-2887 home	Anchor Point/Ninilchik Term Expires July 31, 2007
Bonnie Heimbuch 987 Keystone Drive Soldotna, Alaska 99669	262-6887 - home	Soldotna City Term Expires July 31, 2008
Dr. Rick Foster P.O. Box 3328 Homer, AK 99603-3328	235-9100 - home	Homer City Term Expires July 31, 2007
Mari Anne Gross 57485 Clover Avenue Homer, Alaska 99603	235-7330 - home	Southwest Borough Term Expires July 31, 2008
Lynn Hohl P.O. Box 333 Seward, Alaska 99664-0333	224-7300 - home	Seward City Term Expires July 31, 2008
William Hutchinson P.O. Box 2585 Soldotna, Alaska 99669-2585	262-5256 - home	Ridgeway Term Expires July 31, 2007
James Isham P.O. Box 51 Soldotna, Alaska 99669-0051	262-9200 - home	Sterling Term Expires July 31, 2006
Brent Johnson 20773 Porcupine Lane Clam Gulch, Alaska 99568-9713	262-4763 - home	Kasilof/Clam Gulch Term Expires July 31, 2006
Blair Martin P.O. Box 1776 Soldotna, Alaska 99669-1776	283-5227 - home	Kalifornsky Beach Term Expires July 31, 2006
Mark Massion P.O. Box 203 Seldovia, Alaska 99663-0278	234-7575 - home	Seldovia City Term Expires July 31, 2006
Todd Petersen P.O. Box 651 Seward, Alaska 99664-0651	288-5050 - home 224-3350 - work 224-2388 - work fax	East Peninsula Term Expires July 31, 2007
Ray Tauriainen P.O. Box 8678 Nikiski, Alaska 99635-8678	776-8885 - home	Northwest Borough Term Expires July 31, 2008

Email address for the Planning Commission: [planning@borough.kenai.ak.us](mailto:planning@borough.kenai.ak.us)

Fax Number for the Planning Commission: 907-262-8618

Table 8.3

# KPB Local Officials Directory

## **Kenai Peninsula Borough School District**

148 North Binkley Street  
Soldotna, AK 99669  
907-262-5846

### **Board of Education**

Lorraine Crawford, President	36615 Chinula Drive Kenai, AK 99611	907-283-9271	Term Expires 2007
Sandra Wassilie, Vice President	PO Box 1576 Seward, AK 99664	907-224-3950	Term Expires 2007
Debra Mullins, Clerk	53630 Redoubt Drive Kenai, AK 99611	907-776-5250	Term Expires 2005
Margaret Gilman, Treasurer	216 Susianna St. Kenai, AK 99611	907-283-0860	Term Expires 2006
Marty Anderson	P.O. Box 1388 Sterling, AK 99672	907-260-7500	Term Expires 2006
Nels Anderson, MD	303 Diane Lane Soldotna, AK 99669	907-262-3280	Term Expires 2005
Debbie Brown	P.O. Box 592 Kasilof, AK 99610	907-262-4551	Term Expires 2005
Deborah Germano	P.O. Box 1511 Homer, AK 99603	907-235-2538	Term Expires 2006
Sunni Hilts	P.O. Box 144 Seldovia, AK 99663	907-234-7692	Term Expires 2007
Student Representative DJ Tyson	Kenai Central High School 9853 Kenai Spur Hwy Kenai, AK 99611		Term Expires 2005

Table 8.4

### **Administration**

Dr. Donna Peterson, Superintendent of Schools  
Sam Stewart, Assistant Superintendent  
Gary Whiteley, Assistant Superintendent of Instruction  
Melody Douglas, Chief Financial Officer  
Tim Peterson, Director of Human Resources

Table 8.5

# KPB Local Officials Directory

Kenai Peninsula Borough Department Directors	
Switchboard	262-4441
Assessing	Shane Horan
Capital Projects	Rob Robson
Clerk	Sherry Biggs
Finance	Scott Holt
Legal	Colette Thompson
Maintenance	Dave Tressler
Resource Planning	Max Best
Road Maintenance	Gary Davis
Solid Waste	Cathy Mayer

Table 8.6

Kenai Peninsula Borough Economic Development Agencies
<b>KPB Community &amp; Economic Development Division - CEDD</b>
Jack Brown – Business Manager 43335 Kalifornsky Beach Road, Suite 16 Soldotna, AK 99669 907-714-2336
<b>KP Economic Development District - EDD</b>
14790 Kenai Spur Highway, Ste. 106A Kenai, AK 99611 907-283-3335
<b>Kenai Peninsula Tourism Marketing Council</b>
14790 Kenai Spur Highway, Ste. 103A Kenai, AK 99611 907-262-5229
<b>KP Resource Conservation and Development, Inc.</b>
Trading Bay Plaza, Suite 150 PO Box 800, Kenai, AK 99611 907-283-7493

Table 8.7