

Index

	Page #
Introduction -----	2
Executive Summary-----	5
Kenai Peninsula Borough	
Sales – KPB Finance Department -----	13
Construction – City administrations throughout KPB -----	27
Employment – State of Alaska Department of Labor & Workforce Development -----	40
Population – U.S. Census Bureau, AK Dept of Labor & Workforce Development -----	45
Homer	
Sales – KPB Finance Department -----	51
Construction – City of Homer -----	57
Cost of Food – University of Alaska Fairbanks Cooperative Extension -----	63
Population - U.S. Census Bureau-----	65
Kenai	
Sales – KPB Finance Department -----	67
Construction – City of Kenai-----	73
Cost of Food – University of Alaska Fairbanks Cooperative Extension -----	79
Population - U.S. Census Bureau-----	81
Seldovia	
Sales – KPB Finance Department -----	83
Seldovia Construction – City of Seldovia -----	89
Population - U.S. Census Bureau-----	92
Seward	
Sales – KPB Finance Department -----	93
Construction – City of Seward-----	99
Cost of Food – University of Alaska Fairbanks Cooperative Extension -----	105
Population - U.S. Census Bureau-----	107
Soldotna	
Sales – KPB Finance Department -----	109
Construction – City of Soldotna -----	115
Cost of Food – University of Alaska Fairbanks Cooperative Extension -----	121
Population - U.S. Census Bureau-----	123
Other	
Sales – KPB Finance Department -----	125
Directory of Local Officials-----	131

Data Sources are listed in each subsection.

Introduction

Kenai Peninsula Borough (KPB) staff develops quarterly reports containing economic data from throughout the area for use by businesses, agencies, and other entities to make planning and management decisions.

The publication is divided into eight sections: Kenai Peninsula Borough, Homer, Kenai, Seldovia, Seward, Soldotna, KPB Unincorporated, and a Local Officials Directory.

To provide unity within the document, certain conventions are applied:

- In the real estate section, the following abbreviations apply:
 - NR- New Residential
 - RA - Residential Alteration/Addition
 - NC – New Commercial
 - CA - Commercial Alteration/Addition

- In Sales and Employment sections, the following industry abbreviations apply:
 - AFF – Agriculture, Forestry and Fisheries (Includes Fish Buyers)
 - Min – Mining (Includes Oil & Gas Extraction and Production)
 - Const – Construction
 - Manu – Manufacturing (Includes Oil & Gas Manufacturing and Fish Processing)
 - TCPU – Travel, Communications, and Public Utilities
 - Whole – Wholesale Trade
 - Retail – Retail Trade
 - FIRE – Finance, Insurance and Real Estate
 - Service – Services
 - Govt – Public Administration, Education and Service

- Information sources for each section are listed in the index.

- General information applicable to all sections is provided in the Kenai Peninsula Borough section.

- Percentages of parts may not total 100%, due to rounding.

Information presented will assist in decision-making by providing economic and demographic information in graphic, table and text form. Local and state government officials; local, state and federal agencies; businesses within the borough and elsewhere; and private citizens use data contained in the publication.

Data is received from various sources and is subject to change as updates, revisions and corrections are received. The KPB makes no claims to accuracy or completeness of information provided. Only summary information is published. For further detail, contact Jeanne Camp, Economic Analyst, KPB Community and Economic Development Division, 907-714-2336, or the data source listed in the index.

Quarterly reports are available electronically on the KPB website located at <http://www.borough.kenai.ak.us>.

To correct your mailing address or to be added to or deleted from the mailing list for this report, please email jcamp@borough.kenai.ak.us or call 907-714-2336. Be certain to identify yourself and the complete mailing address to be added or deleted.

The Kenai Peninsula Borough wishes to thank all entities listed below for data provided for this publication.

Alaska Department of Labor and Workforce Development (AK DOL)
City of Homer
City of Kenai
City of Seldovia
City of Seward
City of Soldotna
Kenai Peninsula Borough Finance Department, Sales Tax Division

The writer wishes to thank those persons who gave of their time to review this document, finding errors and making suggestions that result in a more professional and accurate document. Those individuals include Jack Brown, Business Manager of the KPB Community and Economic Development Division; Jane Stein, Community Volunteer; Betty Glick, KPB Assembly member; and Sylvia Vinson, KPB Planning Department.

Functions of the CEDD and the EDD

Frequent questions regarding differences between KPB the Community Economic Development Division (CEDD) and the Economic Development District (EDD) suggest the need for an explanation. The table below defines the differences.

	CEDD	EDD
Funding	Funded by KPB, federal and state grants	Funded by grants – federal, state, borough
Powers	Non area-wide economic development power, only unincorporated areas	Borough-wide economic development powers
Projects	Works on special projects for the mayor	Assists in KPB long-term economic planning
	Develops, monitors KPB grant funding	Sponsors community economic forums
	Publishes historical/current economic data	Assists in community strategic planning
	Oil and Gas liaison	

What is a “Moving Average Trendline?”

Charts in the KPB economic reports frequently include “moving average trendlines.” After individuals read the documents, comments make their way back to the office. One comment that has been heard several times addresses these trendlines, noting that they are not labeled correctly. They are. A description of “trendline” is in order.

The purpose of a trendline is to demonstrate the average of data groupings and how that average relates to averages of similar groupings within the chart.

Imagine that a bar chart illustrates twelve quarters of data and the subtitle states “With Four Quarter Moving Average Trendline.” The trendline begins at the fourth entry in the series and marks the point representing the average of the first through the fourth numbers in the series, in this case a 1st, 2nd, 3rd and 4th quarter value, one year. The trendline continues to the right in the chart. As the trendline reaches the next entry in the series, the line will move to the point on the scale representing the average of the second through the fifth entries in the series – still four quarters of data; but, this time those values would be the 2nd, 3rd and 4th quarter of the first year plus the 1st quarter of the second year.

The process continues through the chart. As the line moves through the chart, it drops the entry marking the beginning of the previous trend point average, adds the entry just ahead of the previous set of four and indicates the average of the new set of four numbers in the series. The resulting “smoothing” effect allows the reader to more easily see change from one year to the next.

Executive Summary

Kenai Peninsula Borough (KPB) industry diversity proved to be an asset during first quarter 2005 as some sectors experienced double digit growth, others double-digit decline. As the most diverse economy in Alaska, the KPB economic system gained strength from its diversity as industry sectors expanded or contracted. The KPB tourism outlook for 2005 indicates continued growth. The commercial fishing industry anticipates another strong year with the sockeye return forecast to increase 200,000 over the 2004 strong run. Demand for the Kenai Wild sockeye is increasing, further improving the outlook. Oil & gas industry participants continue to explore and develop within the KPB. Support industries will benefit from projects in the KPB as well as from projects such as the Pebble Mine located in the Lake and Peninsula Borough west of the Kenai Peninsula Borough.

First quarter sales expanded as gross sales increased 2.3% from \$360,872,443 during first quarter 2004 to \$369,092,946 during 2005, an \$8,220,503 increase. Taxable sales increased 0.7% to \$140,836,157 from \$139,896,835, a \$939,322 increase.

Construction activity appears strong, even in the face of a substantial decrease in values. First quarter values during 2004 set a new record high, easily exceeding the 1995 high, so the decline is not unexpected. Values for the period decreased 61.6% to \$6,475,255 but produced the fifth highest value on record. The quarterly permit value was \$16,851,943 during 2004 while the 2003 value was \$5,255,313. While total value decreased, volume increased 56.8% from 37 permits a year ago to 58 for first quarter 2005. Forty-six permits were issued during first quarter 2003.

Each of the four employment indicators showed improvement, month for month, when compared to January, February and March of 2004. The labor force increased by 290, 157 and 182 persons over the same months. Unemployment was down 266, 206, and 448 persons over the three-month period. The resultant unemployment rates were down 1.4, 1.0 and 2.2 points during January, February and March 2005, respectively. Finally, employment increased by 556, 363 and 630 persons for the three respective months. The four factors combine to indicate increasing strength during March.

Issues in the oil & gas industry are many and varied as known natural gas reserves decrease. At the end of 2004, the reserves estimate in the Cook Inlet Basin marked the first increase in several years as exploration resulted in improved reserves, more than matching product used during 2004. Experts feel the Outer Continental

Shelf region in the Cook Inlet is unexplored, resulting in Alaska offering exploration incentives for the area. The increased use of natural gas during the winter months has raised the issue of gas storage from summer production, which could be used if needed during the winter months, when demand is greatest. There have been some discussions regarding development of the Kenai National Wildlife Refuge. Other issues include extension of oil platform lives in the Cook Inlet Basin, making them economically viable while recovering the more difficult oil reserves. Two gas exploration wells have been successful, located on the west side of Cook Inlet.

Presently, the largest concern in the oil & gas industry is the announced closure of Agrium's fertilizer plant in Nikiski unless economically viable supplies of gas are found. Although the company does not plan to sell the plant, they project closure near the end of 2005. As a result, the Regulatory Commission of Alaska is investigating the Cook Inlet Gas Gathering System, to determine if it should be a regulated part of the infrastructure. Agrium recently requested proposals for gas supplies, indicating they were willing to increase the price they would pay for gas to remain operational. The governor appointed a task force to study the situation.

Population data for 2004 indicates a 0.8% decrease across the KPB for 2004, and each of the incorporated cities experienced a decline. The Homer population declined 9.1%, Kachemak City was down 0.6%, Kenai declined 4.4%, Seldovia dropped 5.7%, Seward decreased 7.5%, and finally, Soldotna's population dropped 5.6%. Perhaps this trend has reversed because the labor force increased each of the first three months of 2005 over 2004, and employment has done the same.

SALES

Initial data for first quarter 2005 indicate gross sales of \$369,092,946, 2.3% more than the \$360,872,443 in sales during 2004, a gain of \$8,220,503. Taxable sales increased 0.7% from \$139,896,835 during 2004 to \$140,836,157 during the most recent quarter, with five of ten sectors with increasing sales. The increase in taxable sales for the quarter was \$939,322.

It must be noted that, effective April 2004, a change in sales reporting options became effective. Businesses that have less than \$6,000 in taxable sales annually, and meeting other reporting requirements, may opt to report all sales annually during fourth quarter, rather than quarterly. This skews quarterly sales data, with fewer sales reported during first, second and third quarter, but increased sales

reported during fourth quarter when sales for the year will be reported. The effect of this action is particularly strong in the manufacturing sector, where sale of value-added products in both commercial fishing and oil & gas are generally classified as non-taxable as they enter the distribution system. Sale of wholesale goods are also skewed by the action. Our sales tax system is intended to tax only the final sale, which generally occurs in retail sales to the consumer.

Quarterly Sales

Gross by Industry. In spite of the 65.1% decline in reported gross manufacturing sales, total gross sales increased 2.3%, increasing from \$360,872,443 to \$369,092,946 from first quarter 2004 to first quarter 2005. Two other industries marked declines in gross sales: Finance, Insurance and Real Estate (FIRE) sales declined 15.3% from \$13,304,735 to \$11,269,988 and sale of wholesale goods decreased 12.2% from \$41,782,771 to \$36,667,868.

Mining sales increased 0.1% to \$39,831,609 while service sector sales increased 1.3% or \$549,399 to \$43,629,834. The 1.8% expansion in retail sales provided \$129,130,943 in sales, a \$2,299,039 gain. Agriculture, Forestry and Fishing (AFF) sales of \$2,951,383 were 26.1% greater than one year ago, increasing \$610,457. Construction sales reached \$38,194,463, gaining 33.3%. Finally, Transportation, Communication and Public Utilities (TCPU) sales grew by 49.6% to \$58,281,566. Government sales increased 11.4% but the \$15,214 in sales is not of consequence in the \$370 million total picture. (See page 15 for detail.)

Taxable by Industry. Taxable sales increased 0.7% for the quarter, a gain of \$939,322 to reach \$140,836,157. The 1.1% gain in retail sales, equivalent to \$875,760, coupled with gains in other sectors, was strong enough to overcome a 13.4% decline in reported manufacturing sales – down \$202,180, a 13.0% decrease in reported wholesale goods sales – down \$766,000, and an 8.1% drop in FIRE sales – down \$394,737. The reporting deadline may be a reflection of sales that were not reported during first quarter but will be reported during fourth quarter as a result of the change in taxable sales reporting options.

In addition to retail sales, TCPU sales increased 9.7% to \$23,066,441; AFF sales increased 4.6% to \$930,189 and mining sales rose 3.8% to \$1,087,830. Construction sales decreased from \$2,217,009 to \$2,016,842, sales in wholesale goods dropped 13% to \$5,126,430 and manufacturing sales totaled \$1,309,950, down from \$1,512,130 during 2004. Government sales increased 11.9% to \$15,214, an inconsequential amount. (See page 16 for detail.)

Gross by Area. The six reporting areas were evenly split with three areas experiencing gains, three reporting sales declines. Overall, gross sales increased 2.3%. Kenai led the charge with sales increasing 22.1% to \$74,587,278 with strong TCPU sales. Seward sales gained 13.8% to reach \$24,087,155 due to construction sales. Lastly, Homer gross sales of \$49,752,632 marked a 3.3% gain.

Seldovia businesses reported declining sales, down 12.1%, to \$1,235,684, largely as a result of a decrease in construction sales, which were exceptionally strong a year ago. Soldotna sales contracted 7.9%, to \$64,359,653, with strength in construction but weakness in wholesale goods. Lastly, sales in the unincorporated area of the KPB decreased 2.6% to \$155,070,544. (See detail on page 17.)

Taxable by Area. Taxable sales are not impacted so heavily by the change in reporting options and increased 0.7% for the quarter. Seward sales increased 4.7% to \$9,943,549; Soldotna sales gained 1.8% to reach \$38,071,634; and, with sales of \$39,575,966, the KPB unincorporated area gained 1.3%.

Homer taxable sales decreased 1.6% to \$23,444,569 while Kenai sales dropped 1.0% to \$29,236,679. Finally, sales in Seldovia decreased 0.5% to total \$563,760. (See detail on page 18.)

Annual Sales

KPB 2004 annual gross sales of \$2,222,004,286 were 15.7% above those of 2003 as seven sectors reported improved sales and three had declining sales. Total 2003 sales of \$1,920,035,537 were 2.2% greater than 2002 sales of \$1,877,961,633. These, in turn, were 4.6% less than 2001 sales of \$1,967,506,986. Each area had increased gross sales from 2003 to 2004.

Taxable sales increased 6.4% from 2003 to 2004 with sales reaching \$780,093,713, following a 1.2% increase from 2002 to the 2003 level of \$732,852,339. The 2.6% gain from 2001 to 2002 resulted in sales of \$724,232,961. All areas had increased taxable sales from 2003 to 2004.

Gross by Industry. Dynamics within the various industry sectors are notable as comparisons are made between 2003 and 2004 sales. Only two sectors had single digit changes. All the rest, gains or losses, were double-digit percentage changes, the largest being 88.5% in the construction industry where sales grew from

\$194,212,922 to \$366,072,552. Next, with a 55.2% increase, mining sales increased from \$106,561,739 to \$165,354,111. The AFF sector gained 25.5%, with sales of \$27,631,235, up from \$22,009,310 during 2003. TCPU sales of \$181,051,679 marked a 14.3% gain, up from \$158,372,166. FIRE sales increased 11.8% to reach \$64,843,380. The second largest sector, services, gained 11.1%, or \$30,756,093, to total \$308,996,885, while the largest sector, retail sales, increased sales by 8.6% to \$699,834,751, a gain of \$55,139,289.

Manufacturing sales of \$170,708,311 decreased 14.4% while construction sales decreased 8.1% to \$237,476,277, perhaps a factor of the change in reporting options. The inconsequential \$35,105 in government sales marked a 16.4% decrease. (See detail on page 19.)

Taxable by Industry. All sectors except government marked growth for the 2004 calendar year, resulting in a 6.4% borough-wide taxable sales increase. Mining sales grew 12.6% to \$5,502,300 joined by AFF sales in double-digit gains, rising 10.3% to \$5,525,243. Retail sales increased 7.5% while services increased 7.0% with sales of \$461,616,411 and \$154,902,802, respectively. Retail and service sales accounted for 79.1% of all taxable sales for the year. Manufacturing sales grew 6.7% to reach \$9,859,796 and sale of wholesale goods increased 6.1%, for \$25,769,380 in sales. The 1.6% gain in TCPU sales brought sector sales to \$82,707,524. Percentagewise, FIRE and construction sales rose the least, 0.6% and 0.1%, with \$22,880,826 and \$11,294,391 in sales, respectively.

Government's 16.5% sales drop to \$35,040 is inconsequential. (Detail on page 20)

Gross by Area. The Kenai 65.6% sales expansion was a result of TCPU sales, which increased 212.9%, helping Kenai sales total \$469,300,234 for the year. Seldovia sales of \$8,325,201 were 14.7% above one year ago. Sales in the unincorporated area grew 8.5%, to \$933,477,858 while Soldotna sales of \$361,104,164 were 6.9% greater than one year ago. Seward, with \$166,135,648 in sales, marked a 5.8% gain while Homer sales increased 3.5% to reach \$283,661,181. (See detail on page 21.)

Taxable by Area. Kenai taxable sales increased 14.3%. leading the way to a borough-wide 6.4% increase during 2004. Total KPB sales reached \$780,093,713 as Kenai sales totaled \$138,627,446 for the year. Homer sales increased 6.4% to \$140,057,562. Soldotna sales gained 4.9% to total \$200,050,269 while Seward saw a 4.7% increase with sales of \$79,929,511. Seldovia sales marked a 0.1% increase to total \$3,381,682. (See detail on page 22.)

CONSTRUCTION PERMITTING

Quarterly Permitting

Fifty-eight construction permits were issued in KPB cities during first quarter 2005, a 56.8% increase over first quarter 2004 when 37 permits were issued. Total permit value declined 61.6% to \$6,475,255. The decline is not of concern because total value is fifth highest since 1986 and 2004 permit values were exceptionally high. The record year, 1995, was a result of the Seward SeaLife Center permit. Data in this section does not include construction activity outside incorporated cities of Homer, Kenai, Seldovia, Seward and Soldotna because the KPB does not require building permits.

By Area, Value. Homer permit values decreased 16.4% but provided 48% of KPB first quarter total permit values, \$6,475,255. Homer permits totaled \$3,105,900. Seward permitting provided 23.3% of quarterly value, issuing permits totaling \$1,507,300. Soldotna's total permit value, \$1,421,555, was 22% of the borough-wide total. Kenai issued permits valued at \$425,500 and added 6.6% to the total. Seldovia issued a \$15,000 permit during first quarter of 2004. (See detail on page 28.)

By Area, Volume. All reporting areas experienced a first quarter increase in permitting activity as 58 permits were issued. Homer increased from 16 to 18 permits; Soldotna gained 77.8%, moving from nine to 16 permits; Seward increased from seven permits to 13, an 85.7% increase while Kenai reported a 150% increase, from four permits during 2004 to ten permits this year. Seldovia issued one permit, as it did first quarter 2004. (See detail on page 29.)

By Type, Value. New residential permit values increased 0.4% to total \$3,470,356 during first quarter 2005 and provided 53.6% of the total. Commercial alterations followed with 32.1% of the total, \$2,076,969. New commercial permit values decreased from \$12,880,026 to \$509,000, adding 7.9% of the total. Residential alteration/addition permit values of \$418,930, increased 60.2% over 2004. (See detail on page 30)

By Type, Volume. Distribution of permitting during first quarter 2005 was fairly well divided as 19 permits were issued for commercial alteration projects, 18 for new residential projects, and fifteen for residential alteration. Each of these

marked an increase over 2004. Only new commercial permitting decreased, as six permits were issued. (See detail on page 31.)

Annual Construction

Construction permit values during 2004 set a new record high, easily surpassing the previous high, 1995, when the Seward SeaLife Center was permitted. Year 2004 will now set the standard, as permitted values totaled \$84,041,457, overcoming the previous annual high, \$61,670,382. Projects included expansion of Central Peninsula General Hospital, expansion of the Fred Meyer store and the new Trustworthy Hardware store, all located in Soldotna.

There were 312 permits issued during 2004, 7.1% fewer than the 336 issued during 2003 and the 351 issued during 2002, but third highest on record. Homer issued the greatest number of permits, and 34.6% of the KPB total.

By Area, Value. Soldotna's issuance accounted for 44.4% of the total, with values reaching \$37,296,926. Homer followed closely with \$24,070,631 in permit value and 28.6% of the total. Seward issued \$17,711,150 in construction permits for the year, 21.1% of the KPB total. Kenai added another \$4,786,550 in permits and 5.7% of the total while Seldovia provided the last \$176,200. (See detail on page 32.)

By Area, Volume. During 2004 Homer issued 108 of the 312 permits, providing 34.6% of the KPB total. Kenai issued 79 permits while Soldotna issued 67, for 25.3% and 21.5% of the total, respectively. Seward issued 54 permits, 17.3% of the total and Seldovia's four permits completed the count. Homer issued 25.6% more permits than during 2003 and Seward's count increased by 8.0%. Areas with declining permit activity include Kenai, down 30.7%, Seldovia was down 66.7% and Soldotna issued 9.5% fewer than one year ago. (See detail on page 33.)

By Type, Value. New commercial projects provided 66.7% of permit activity, \$56,079,343 as new residential permits provided 19% of the total, \$15,935,344. Commercial alteration/addition permit values totaled \$9,146,486 or 10.9% of the total. Finally, residential alteration/addition permits added \$2,880,284 for 3.4% of the KPB total. New residential permit values were 1.3% above 2003 while residential alteration total values increased 26.3%. New commercial values increased 254.5% while the residential alteration/addition total value was down 6.4%. (See detail on page 34.)

By Type, Volume. With 312 permits issued, residential alteration permitting increased from 94 permits during 2003 to 96 during 2004. New commercial permitting was stable at 42 permits each year. New residential permit activity for 2003 decreased 9.6% from 104 to 94 permits. Eighty commercial alteration/addition permits were issued, down from 96 during 2003, down 16.8%. There were 336 permits issued during 2003. (See detail on page 35.)

EMPLOYMENT

KPB's January 2005 labor force had 21,856 persons, decreasing to 21,841 potential employees during February but rebounding to 21,980 during March. The March 2005 labor force was 182 persons greater than one year ago.

The KPB had 2,690 persons listed as unemployed during January 2005. That number increased to 2,763 during February but reversed to 2,449 during March. The March 2005 unemployed total was 448 less than March 2004.

KPB's January 2005 employment rate of 12.3% was down from 13.7% during January 2004. The rate increased to 12.7% during February, but improved during March to 11.1%. The March 2004 rate was 13.5%.

Employment during January 2005 rose to 19,166 from 18,610 a year earlier, climbed to 19,078 during February and on up to 19,531 during March. This compares with 18,715 during February 2004 and 18,901 during March 2004. (See detail on pages 40-44.)

POPULATION

Population estimates for 2004 show the Kenai Peninsula population at 50,980 persons, a 0.8% decrease for the year. Each of the incorporated cities also marked decreases. Homer dropped 9.1% to 5,332 while Kachemak City lost 0.6% to a total of 475 persons. Kenai also decreased, losing 4.4% to 6,809 residents. Seldovia decreased 5.7% to 263 and Seward lost 7.5%, down to 2,540 persons. Soldotna's population is down 5.6% to 3,767. Alaska's population, estimated at 655,435 for 2004, marked a 1.1% increase for the year. (See page 46 for detail.)

KPB Sales

KPB 1st Quarter Taxable Sales by Area - 1999-2005 - in \$								
	1999	2000	2001	2002	2003	2004	2005	Annual Change
Homer	16,638,467	17,327,860	17,765,204	18,697,104	22,449,940	23,826,122	23,444,569	-1.6%
Kenai	25,183,897	25,521,513	27,889,241	28,938,342	31,093,476	29,545,991	29,236,679	-1.0%
Seldovia	569,438	569,093	583,555	573,624	598,970	566,726	563,760	-0.5%
Seward	9,218,678	9,374,360	9,073,493	9,051,044	9,289,341	9,493,481	9,943,549	4.7%
Soldotna	28,439,928	29,664,420	32,492,377	33,736,608	34,463,622	37,383,328	38,071,634	1.8%
KPB Unincorporated	34,348,468	35,696,361	38,055,259	41,804,884	38,385,673	39,081,187	39,575,966	1.3%
Total	114,398,876	118,153,607	125,859,129	132,801,606	136,281,022	139,896,835	140,836,157	0.7%
Annual Change		3.3%	6.5%	5.5%	2.6%	2.7%	0.7%	

Table 1.10

KPB 1st Quarter Taxable Sales Ten Year Change by Area - 1995 v 2005 - in \$				
	10 Year Change			
	1995	2005	Percentage	Numerical
Homer	14,797,530	23,444,569	58.4%	8,647,039
Kenai	22,811,754	29,236,679	28.2%	6,424,925
Seldovia	602,805	563,760	-6.5%	-39,045
Seward	7,674,012	9,943,549	29.6%	2,269,537
Soldotna	23,569,520	38,071,634	61.5%	14,502,114
KPB Unincorporated	29,644,424	39,575,966	33.5%	9,931,542
Total	99,100,045	140,836,157	42.1%	41,736,112

Table 1.11

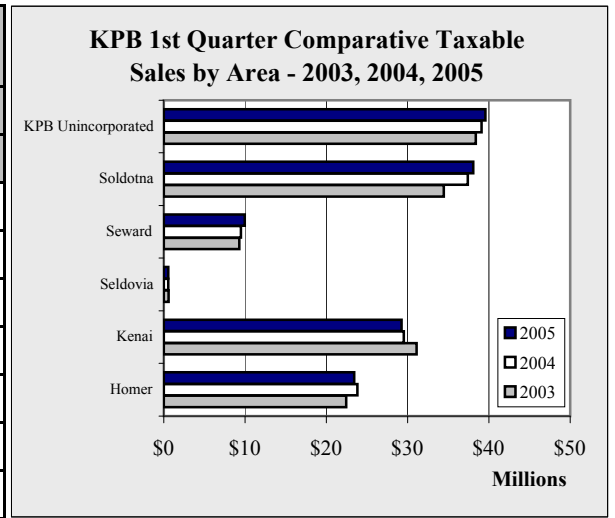

Chart 1.9

KPB 1st Quarter Taxable Sales One Year Change by Area - 2004 v 2005 - in \$				
	1 Year Change			
	2004	2005	Percentage	Numerical
Homer	23,826,122	23,444,569	-1.6%	-381,553
Kenai	29,545,991	29,236,679	-1.0%	-309,312
Seldovia	566,726	563,760	-0.5%	-2,966
Seward	9,493,481	9,943,549	4.7%	450,068
Soldotna	37,383,328	38,071,634	1.8%	688,306
KPB Unincorporated	39,081,187	39,575,966	1.3%	494,779
Total	139,896,835	140,836,157	0.7%	939,322

Table 1.12

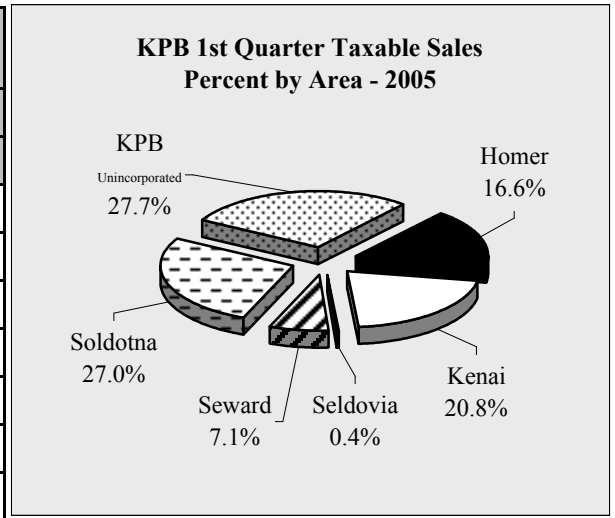

Chart 1.10

KPB Sales

KPB Annual Gross Sales by Industry - 1998-2004 - in \$

	1998	1999	2000	2001	2002	2003	2004	Annual Change
AFF	30,373,442	32,347,943	24,816,872	17,584,763	16,750,059	22,009,310	27,631,235	25.5%
Min	190,689,442	115,241,075	121,868,065	126,250,792	113,521,181	106,561,739	165,354,111	55.2%
Const	187,102,648	166,008,223	185,994,582	241,706,588	229,399,098	258,447,580	237,476,277	-8.1%
Manu	147,360,433	165,066,528	117,856,947	287,725,053	201,047,383	199,442,339	170,708,311	-14.4%
TCPU	159,766,641	169,321,042	156,272,089	173,246,581	172,554,610	158,372,166	181,051,679	14.3%
Whole	149,117,372	155,121,630	171,235,874	177,036,125	188,223,387	194,212,922	366,072,552	88.5%
Retail	547,202,550	545,752,691	580,370,933	633,597,773	625,008,358	644,695,462	699,834,751	8.6%
FIRE	50,782,517	51,186,806	50,390,903	54,153,772	54,924,793	58,011,247	64,843,380	11.8%
Service	211,144,805	220,251,298	235,820,173	256,185,223	276,510,185	278,240,792	308,996,885	11.1%
Govt	26,751	28,814	17,350	20,316	22,579	41,980	35,105	-16.4%
Total	1,673,566,601	1,620,326,050	1,644,643,788	1,967,506,986	1,877,961,633	1,920,035,537	2,222,004,286	15.7%
Annual Change		-3.2%	1.5%	19.6%	-4.6%	2.2%	15.7%	

Table 1.13

KPB Annual Gross Sales Ten Year Change by Industry - 1994 v 2004 - in \$

			10 Year Change	
	1994	2004	Percentage	Numerical
AFF	55,520,292	27,631,235	-50.2%	-27,889,057
Min	124,428,885	165,354,111	32.9%	40,925,226
Const	144,672,165	237,476,277	64.1%	92,804,112
Manu	125,684,092	170,708,311	35.8%	45,024,219
TCPU	216,882,266	181,051,679	-16.5%	-35,830,587
Whole	88,960,238	366,072,552	311.5%	277,112,314
Retail	406,692,795	699,834,751	72.1%	293,141,956
FIRE	55,375,125	64,843,380	17.1%	9,468,255
Service	165,995,597	308,996,885	86.1%	143,001,288
Govt	10,251	35,105	242.5%	24,854
Total	1,384,221,706	2,222,004,286	60.5%	837,782,580

Table 1.14

KPB Annual Gross Sales One Year Change by Industry - 2003 v 2004 - in \$

			1 Year Change	
	2003	2004	Percentage	Numerical
AFF	22,009,310	27,631,235	25.5%	5,621,925
Min	106,561,739	165,354,111	55.2%	58,792,372
Const	258,447,580	237,476,277	-8.1%	-20,971,303
Manu	199,442,339	170,708,311	-14.4%	-28,734,028
TCPU	158,372,166	181,051,679	14.3%	22,679,513
Whole	194,212,922	366,072,552	88.5%	171,859,630
Retail	644,695,462	699,834,751	8.6%	55,139,289
FIRE	58,011,247	64,843,380	11.8%	6,832,133
Service	278,240,792	308,996,885	11.1%	30,756,093
Govt	41,980	35,105	-16.4%	-6,875
Total	1,920,035,537	2,222,004,286	15.7%	301,968,749

Table 1.15

KPB Annual Comparative Gross Sales by Industry - 2002, 2003, 2004

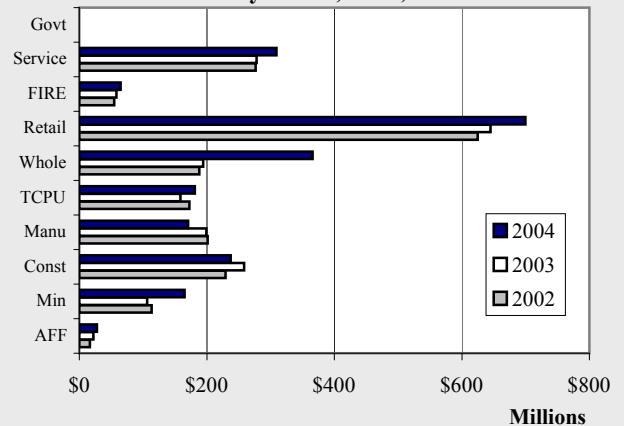

Chart 1.11

KPB Annual Gross Sales Percent by Industry - 2004

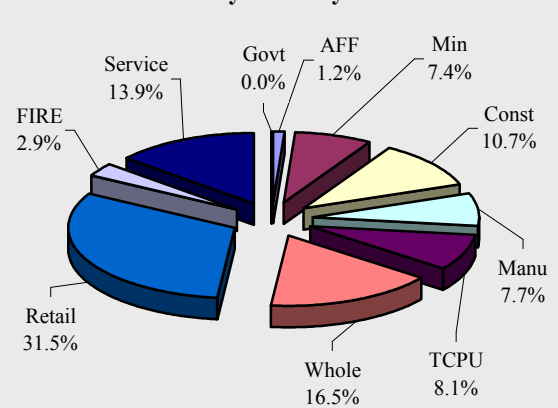

Chart 1.12

KPBR

KPBR Annual Taxable Sales by Industry - 1998-2004 - in \$

	1998	1999	2000	2001	2002	2003	2004	Annual Change
AFF	3,458,989	3,539,802	4,148,862	4,391,790	4,461,252	5,010,961	5,525,243	10.3%
Min	5,202,698	3,828,650	4,613,878	5,863,223	5,848,904	4,885,262	5,502,300	12.6%
Const	9,821,330	9,921,434	9,658,671	10,002,648	10,709,485	11,283,352	11,294,391	0.1%
Manu	9,578,020	9,251,298	9,792,611	9,654,663	9,616,559	9,239,486	9,859,796	6.7%
TCPU	72,108,745	79,282,344	77,420,153	79,415,747	83,947,088	81,373,510	82,707,524	1.6%
Whole	18,357,305	19,290,256	21,493,691	22,282,063	21,690,782	24,282,313	25,769,380	6.1%
Retail	353,131,302	367,123,730	383,777,809	411,721,005	419,549,532	429,266,128	461,616,411	7.5%
FIRE	18,576,711	18,862,816	20,702,551	23,486,072	24,084,827	22,751,829	22,880,826	0.6%
Service	122,225,757	129,434,976	135,510,623	139,066,219	144,301,953	144,717,518	154,902,802	7.0%
Govt	26,744	28,814	17,350	20,316	22,579	41,980	35,040	-16.5%
Total	612,487,601	640,564,120	667,136,199	705,903,746	724,232,961	732,852,339	780,093,713	6.4%
Annual Change		4.6%	4.1%	5.8%	2.6%	1.2%	6.4%	

Table 1.16

KPBR Annual Taxable Sales Ten Year Change by Industry - 1994 v 2004 - in \$

	1994	2004	10 Year Change	
			Percentage	Numerical
AFF	3,454,687	5,525,243	59.9%	2,070,556
Min	6,132,287	5,502,300	-10.3%	-629,987
Const	8,077,694	11,294,391	39.8%	3,216,697
Manu	7,808,695	9,859,796	26.3%	2,051,101
TCPU	64,017,267	82,707,524	29.2%	18,690,257
Whole	19,542,465	25,769,380	31.9%	6,226,915
Retail	299,416,591	461,616,411	54.2%	162,199,820
FIRE	18,378,264	22,880,826	24.5%	4,502,562
Service	100,262,803	154,902,802	54.5%	54,639,999
Govt	10,251	35,040	241.8%	24,789
Total	527,101,004	780,093,713	48.0%	252,992,709

Table 1.17

KPBR Annual Comparative Taxable Sales by Industry - 2002, 2003, 2004

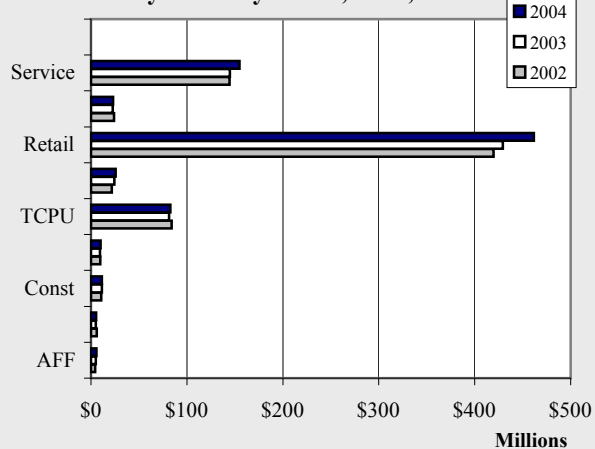

Chart 1.13

KPBR Annual Taxable Sales One Year Change by Industry - 2003 v 2004 - in \$

	2003	2004	1 Year Change	
			Percentage	Numerical
AFF	5,010,961	5,525,243	10.3%	514,282
Min	4,885,262	5,502,300	12.6%	617,038
Const	11,283,352	11,294,391	0.1%	11,039
Manu	9,239,486	9,859,796	6.7%	620,310
TCPU	81,373,510	82,707,524	1.6%	1,334,014
Whole	24,282,313	25,769,380	6.1%	1,487,067
Retail	429,266,128	461,616,411	7.5%	32,350,283
FIRE	22,751,829	22,880,826	0.6%	128,997
Service	144,717,518	154,902,802	7.0%	10,185,284
Govt	41,980	35,040	-16.5%	-6,940
Total	732,852,339	780,093,713	6.4%	47,241,374

Table 1.18

KPBR Annual Taxable Sales Percent by Industry - 2004

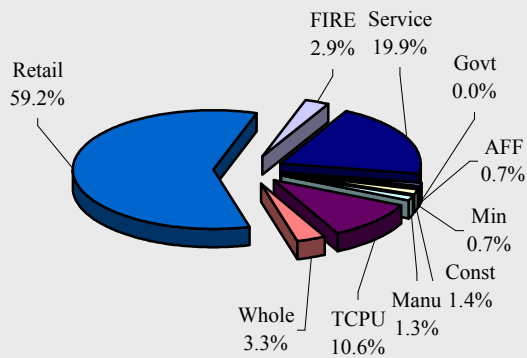

Chart 1.14

KPB Sales

KPB Annual Gross Sales by Area - 1998-2004 - in \$								
	1998	1999	2000	2001	2002	2003	2004	Annual Change
Homer	212,442,617	203,842,475	215,981,724	229,703,507	263,195,800	274,030,866	283,661,181	3.5%
Kenai	280,079,940	270,746,118	283,682,464	310,426,425	279,745,403	283,340,242	469,300,234	65.6%
Seldovia	4,723,739	4,844,770	5,267,325	5,249,471	4,817,877	7,259,554	8,325,201	14.7%
Seward	132,506,248	130,155,521	142,152,279	148,360,553	142,367,126	156,959,598	166,135,648	5.8%
Soldotna	250,793,664	277,588,737	289,255,311	309,118,231	325,899,019	337,772,973	361,104,164	6.9%
KPB Unincorporated	793,020,393	733,148,429	708,304,685	964,648,799	861,936,408	860,672,304	933,477,858	8.5%
Total	1,673,566,601	1,620,326,050	1,644,643,788	1,967,506,986	1,877,961,633	1,920,035,537	2,222,004,286	15.7%
Annual Change		-3.2%	1.5%	19.6%	-4.6%	2.2%	15.7%	

Table 1.19

KPB Annual Gross Sales Ten Year Change by Area - 1994 v 2004				
	10 Year Change			
	1994	2004	Percentage	Numerical
Homer	171,092,369	283,661,181	65.8%	112,568,812
Kenai	249,216,590	469,300,234	88.3%	220,083,644
Seldovia	5,275,307	8,325,201	57.8%	3,049,894
Seward	99,875,014	166,135,648	66.3%	66,260,634
Soldotna	194,609,544	361,104,164	85.6%	166,494,620
KPB Unincorporated	664,152,882	933,477,858	40.6%	269,324,976
Total	1,384,221,706	2,222,004,286	60.5%	837,782,580

Table 1.20

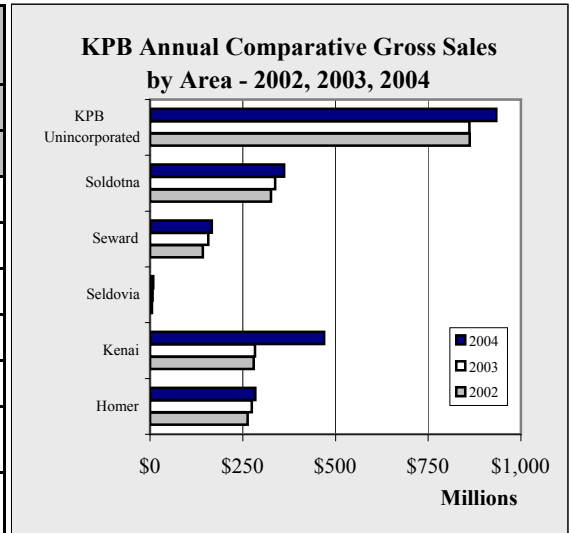

Chart 1.15

KPB Annual Gross Sales One Year Change by Area - 2003 v 2004				
	1 Year Change			
	2003	2004	Percentage	Numerical
Homer	274,030,866	283,661,181	3.5%	9,630,315
Kenai	283,340,242	469,300,234	65.6%	185,959,992
Seldovia	7,259,554	8,325,201	14.7%	1,065,647
Seward	156,959,598	166,135,648	5.8%	9,176,050
Soldotna	337,772,973	361,104,164	6.9%	23,331,191
KPB Unincorporated	860,672,304	933,477,858	8.5%	72,805,554
Total	1,920,035,537	2,222,004,286	15.7%	301,968,749

Table 1.21

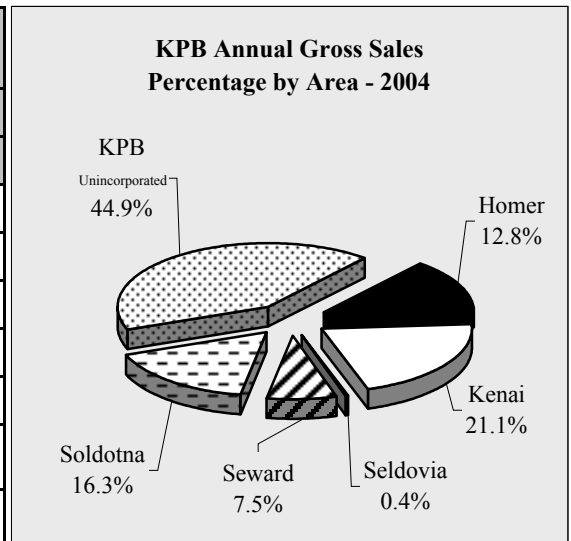

Chart 1.16

KPB Sales

KPB Annual Taxable Sales by Area - 1998-2004 - in \$

	1998	1999	2000	2001	2002	2003	2004	Annual Change
Homer	94,441,342	98,148,738	103,190,116	107,311,539	121,268,118	131,631,725	140,057,562	6.4%
Kenai	120,030,707	124,367,091	127,766,126	137,043,924	136,769,610	121,312,219	138,627,446	14.3%
Seldovia	3,398,293	3,229,249	3,418,123	3,359,279	3,272,389	3,376,944	3,381,682	0.1%
Seward	67,278,264	71,472,199	73,983,426	74,225,591	75,598,696	76,375,738	79,929,511	4.7%
Soldotna	147,789,661	155,952,764	159,436,128	172,418,438	176,977,868	190,616,882	200,050,269	4.9%
KPB Unincorporated	179,549,334	187,394,079	199,342,280	211,544,975	210,346,280	209,538,831	218,047,243	4.1%
Total	612,487,601	640,564,120	667,136,199	705,903,746	724,232,961	732,852,339	780,093,713	6.4%
Annual Change		4.6%	4.1%	5.8%	2.6%	1.2%	6.4%	

Table 1.22

KPB Annual Taxable Sales Ten Year Change by Area - 1994 v 2004 - in \$

	10 Year Change			
	1994	2004	Percentage	Numerical
Homer	84,045,458	140,057,562	66.6%	56,012,104
Kenai	114,402,035	138,627,446	21.2%	24,225,411
Seldovia	3,117,185	3,381,682	8.5%	264,497
Seward	53,259,177	79,929,511	50.1%	26,670,334
Soldotna	119,702,481	200,050,269	67.1%	80,347,788
KPB Unincorporated	152,574,668	218,047,243	42.9%	65,472,575
Total	527,101,004	780,093,713	48.0%	252,992,709

Table 1.23

KPB Annual Comparative Taxable Sales by Area - 2002, 2003, 2004

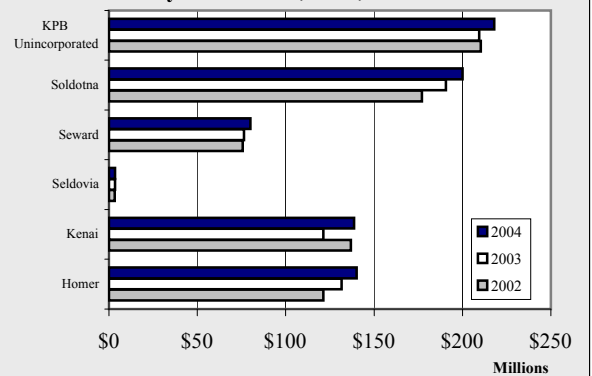

Chart 1.17

KPB Annual Taxable Sales One Year Change by Area - 2003 v 2004 - in \$

	1 Year Change			
	2003	2004	Percentage	Numerical
Homer	131,631,725	140,057,562	6.4%	8,425,837
Kenai	121,312,219	138,627,446	14.3%	17,315,227
Seldovia	3,376,944	3,381,682	0.1%	4,738
Seward	76,375,738	79,929,511	4.7%	3,553,773
Soldotna	190,616,882	200,050,269	4.9%	9,433,387
KPB Unincorporated	209,538,831	218,047,243	4.1%	8,508,412
Total	732,852,339	780,093,713	6.4%	47,241,374

Table 1.24

KPB Annual Taxable Sales Percent by Area - 2004

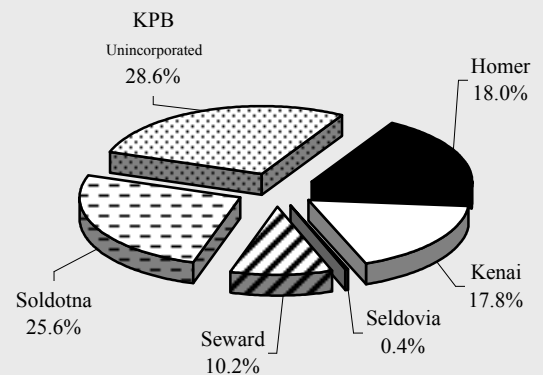

Chart 1.18

KPB Sales

KPB Annual Gross Sales by Industry by Quarter - 2002-2005 - in \$					
	1st Quarter	2nd Quarter	3rd Quarter	4th Quarter	Total
0					
AFF	2,004,841	2,856,503	9,835,705	2,053,010	16,750,059
Min	34,662,385	29,861,507	26,316,221	22,681,068	113,521,181
Const	43,149,133	49,852,546	72,113,003	64,284,416	229,399,098
Manu	21,341,761	44,663,448	56,768,859	78,273,315	201,047,383
TCPU	40,723,392	42,378,179	51,457,523	37,995,516	172,554,610
Whole	37,128,746	46,538,996	57,145,760	47,409,885	188,223,387
Retail	115,899,097	165,285,986	198,420,434	145,402,841	625,008,358
FIRE	12,389,238	14,756,677	15,233,449	12,545,429	54,924,793
Service	43,234,458	77,421,202	109,778,499	46,076,026	276,510,185
Govt	6,700	7,859	4,290	3,730	22,579
Total	350,539,751	473,622,903	597,073,743	456,725,236	1,877,961,633
2003					
AFF	2,019,939	4,045,723	13,491,140	2,452,508	22,009,310
Min	19,260,142	25,083,685	30,366,980	31,850,932	106,561,739
Const	43,362,431	67,758,953	81,935,651	65,390,545	258,447,580
Manu	38,576,448	34,259,747	66,216,357	60,389,787	199,442,339
TCPU	38,217,073	38,841,966	43,819,198	37,493,929	158,372,166
Whole	35,918,425	50,841,751	60,869,241	46,583,505	194,212,922
Retail	123,118,509	170,711,911	201,816,813	149,048,229	644,695,462
FIRE	11,704,586	15,275,186	16,074,854	14,956,621	58,011,247
Service	41,556,541	77,645,713	108,482,303	50,556,235	278,240,792
Govt	12,319	8,680	12,192	8,789	41,980
Total	353,746,413	484,473,315	623,084,729	458,731,080	1,920,035,537
2004					
AFF	2,340,926	3,911,032	15,695,017	5,684,260	27,631,235
Min	39,801,394	32,098,347	39,000,757	54,453,613	165,354,111
Const	28,642,511	42,389,136	67,076,832	99,367,798	237,476,277
Manu	26,107,055	15,540,229	97,207,179	31,853,848	170,708,311
TCPU	38,967,049	35,418,629	55,432,460	51,233,541	181,051,679
Whole	41,782,771	50,630,515	55,365,704	218,293,562	366,072,552
Retail	126,831,904	187,714,938	224,413,635	160,874,274	699,834,751
FIRE	13,304,735	14,402,330	16,956,161	20,180,154	64,843,380
Service	43,080,435	82,270,855	119,932,470	63,713,125	308,996,885
Govt	13,663	8,521	9,184	3,737	35,105
Total	360,872,443	464,384,532	691,089,399	705,657,912	2,222,004,286
2005					
Year to Date					
AFF	2,951,383				2,951,383
Min	39,831,609				39,831,609
Const	38,194,463				38,194,463
Manu	9,120,078				9,120,078
TCPU	58,281,566				58,281,566
Whole	36,667,868				36,667,868
Retail	129,130,943				129,130,943
FIRE	11,269,988				11,269,988
Service	43,629,834				43,629,834
Govt	15,214				15,214
Total	369,092,946				369,092,946

Table 1.25

KPB Sales

KPB Annual Taxable Sales by Industry by Quarter - 2002-2005 - in \$					
	1st Quarter	2nd Quarter	3rd Quarter	4th Quarter	Total
0					
AFF	796,380	1,423,988	1,400,008	840,876	4,461,252
Min	1,482,601	1,484,251	1,550,583	1,331,469	5,848,904
Const	2,037,148	2,677,823	3,288,688	2,705,826	10,709,485
Manu	1,307,744	2,791,765	3,717,020	1,800,030	9,616,559
TCPU	21,573,935	21,477,202	21,106,028	19,789,923	83,947,088
Whole	4,783,261	5,679,123	6,316,722	4,911,676	21,690,782
Retail	76,421,463	109,883,510	136,536,484	96,708,075	419,549,532
FIRE	5,453,086	6,078,006	6,917,181	5,636,554	24,084,827
Service	18,939,288	41,353,274	62,644,991	21,364,400	144,301,953
Govt	6,700	7,859	4,290	3,730	22,579
Total	132,801,606	192,856,801	243,481,995	155,092,559	724,232,961
2003					
AFF	763,045	1,577,278	1,697,754	972,884	5,010,961
Min	1,233,618	1,170,493	1,313,871	1,167,280	4,885,262
Const	2,059,743	3,128,868	3,321,173	2,773,568	11,283,352
Manu	1,438,887	2,607,213	3,333,206	1,860,180	9,239,486
TCPU	21,650,525	20,321,138	19,718,329	19,683,518	81,373,510
Whole	5,052,561	6,337,983	7,103,240	5,788,529	24,282,313
Retail	79,981,563	112,417,564	139,063,076	97,803,925	429,266,128
FIRE	5,309,694	5,975,269	6,458,624	5,008,242	22,751,829
Service	18,779,067	41,517,128	62,826,689	21,594,634	144,717,518
Govt	12,319	8,680	12,192	8,789	41,980
Total	136,281,022	195,061,614	244,848,154	156,661,549	732,852,339
2004					
AFF	889,277	1,674,503	1,979,566	981,897	5,525,243
Min	1,047,668	1,082,504	1,908,215	1,463,913	5,502,300
Const	2,217,009	2,933,623	3,291,595	2,852,164	11,294,391
Manu	1,512,130	2,737,701	3,843,780	1,766,185	9,859,796
TCPU	21,021,541	19,473,926	21,221,357	20,990,700	82,707,524
Whole	5,892,430	6,600,388	7,644,161	5,632,401	25,769,380
Retail	83,151,986	122,379,113	153,285,306	102,800,006	461,616,411
FIRE	4,891,080	5,713,200	6,620,051	5,656,495	22,880,826
Service	19,260,116	44,465,495	69,132,092	22,045,099	154,902,802
Govt	13,598	8,521	9,184	3,737	35,040
Total	139,896,835	207,068,974	268,935,307	164,192,597	780,093,713
2005					
				Year to Date	
AFF	930,189				930,189
Min	1,087,830				1,087,830
Const	2,016,842				2,016,842
Manu	1,309,950				1,309,950
TCPU	23,066,441				23,066,441
Whole	5,126,430				5,126,430
Retail	84,027,746				84,027,746
FIRE	4,496,343				4,496,343
Service	18,759,172				18,759,172
Govt	15,214				15,214
Total	140,836,157				140,836,157

Table 1.26

KPB Sales

KPB Annual Gross Sales by Area by Quarter - 2000-2005 - in \$					
	1st Qtr	2nd Qtr	3rd Qtr	4th Qtr	Total
0					
Homer	38,455,167	59,287,582	70,009,668	48,229,307	215,981,724
Kenai	55,609,576	66,158,563	89,505,566	72,408,759	283,682,464
Seldovia	1,150,692	1,526,900	1,693,636	896,097	5,267,325
Seward	19,087,797	38,014,037	57,260,079	27,790,366	142,152,279
Soldotna	55,201,896	72,515,215	89,530,301	72,007,899	289,255,311
KPB Unincorporated	126,664,981	183,977,517	225,474,396	172,187,791	708,304,685
Total	296,170,109	421,479,814	533,473,646	393,520,219	1,644,643,788
2001					
Homer	40,844,978	56,857,475	77,453,956	54,547,098	229,703,507
Kenai	62,418,286	76,673,936	94,911,501	76,422,702	310,426,425
Seldovia	898,811	1,473,305	1,957,554	919,801	5,249,471
Seward	20,531,272	44,452,278	62,873,649	20,503,354	148,360,553
Soldotna	60,802,277	75,042,511	95,670,432	77,603,011	309,118,231
KPB Unincorporated	170,550,210	217,647,967	286,388,798	290,061,824	964,648,799
Total	356,045,834	472,147,472	619,255,890	520,057,790	1,967,506,986
2002					
Homer	44,264,946	68,671,745	89,690,601	60,568,508	263,195,800
Kenai	60,596,369	67,929,291	82,601,639	68,618,104	279,745,403
Seldovia	1,011,712	1,155,055	1,694,174	956,936	4,817,877
Seward	22,954,013	40,385,376	56,721,649	22,306,088	142,367,126
Soldotna	62,331,750	79,761,648	103,624,839	80,180,782	325,899,019
KPB Unincorporated	159,380,961	215,719,788	262,740,841	224,094,818	861,936,408
Total	350,539,751	473,622,903	597,073,743	456,725,236	1,877,961,633
2003					
Homer	51,228,276	75,287,944	87,188,300	60,326,346	274,030,866
Kenai	62,140,357	67,424,299	81,229,776	72,545,810	283,340,242
Seldovia	847,005	1,629,455	2,833,785	1,949,309	7,259,554
Seward	20,933,260	46,984,153	61,707,771	27,334,414	156,959,598
Soldotna	64,233,718	85,179,197	106,204,940	82,155,118	337,772,973
KPB Unincorporated	154,363,797	207,968,267	283,920,157	214,420,083	860,672,304
Total	353,746,413	484,473,315	623,084,729	458,731,080	1,920,035,537
2004					
Homer	48,142,365	68,967,688	93,918,700	72,632,428	283,661,181
Kenai	61,072,504	74,277,836	97,840,299	236,109,595	469,300,234
Seldovia	1,405,047	1,971,670	1,809,067	3,139,417	8,325,201
Seward	21,166,698	42,746,053	63,920,125	38,302,772	166,135,648
Soldotna	69,911,488	89,308,815	107,178,796	94,705,065	361,104,164
KPB Unincorporated	159,174,341	187,112,470	326,422,412	260,768,635	933,477,858
Total	360,872,443	464,384,532	691,089,399	705,657,912	2,222,004,286
2005					
Year to Date					
Homer	49,752,632				49,752,632
Kenai	74,587,278				74,587,278
Seldovia	1,235,684				1,235,684
Seward	24,087,155				24,087,155
Soldotna	64,359,653				64,359,653
KPB Unincorporated	155,070,544				155,070,544
Total	369,092,946				369,092,946

Table 1.27

KPB Sales

KPB Annual Taxable Sales by Area by Quarter - 2000-2005 - in \$

	1st Qtr	2nd Qtr	3rd Qtr	4th Qtr	Total
0					
Homer	17,327,860	28,797,872	35,677,211	21,387,173	103,190,116
Kenai	25,521,513	31,547,905	36,634,363	34,062,345	127,766,126
Seldovia	569,093	1,018,255	1,241,108	589,667	3,418,123
Seward	9,374,360	21,160,898	32,903,473	10,544,695	73,983,426
Soldotna	29,664,420	38,766,616	50,523,183	40,481,909	159,436,128
KPB Unincorporated	35,696,361	55,205,057	66,472,925	41,967,937	199,342,280
Total	118,153,607	176,496,603	223,452,263	149,033,726	667,136,199
2001					
Homer	17,765,204	30,191,477	37,574,702	21,780,156	107,311,539
Kenai	27,889,241	34,988,669	38,162,815	36,003,199	137,043,924
Seldovia	583,555	956,033	1,207,525	612,166	3,359,279
Seward	9,073,493	21,553,264	33,591,333	10,007,501	74,225,591
Soldotna	32,492,377	42,914,074	54,143,248	42,868,739	172,418,438
KPB Unincorporated	38,055,259	57,871,082	68,857,364	46,761,270	211,544,975
Total	125,859,129	188,474,599	233,536,987	158,033,031	705,903,746
2002					
Homer	18,697,104	34,267,489	43,251,111	25,052,414	121,268,118
Kenai	28,938,342	34,649,565	38,192,980	34,988,723	136,769,610
Seldovia	573,624	898,830	1,191,989	607,946	3,272,389
Seward	9,051,044	22,176,474	34,338,060	10,033,118	75,598,696
Soldotna	33,736,608	43,503,934	57,488,623	42,248,703	176,977,868
KPB Unincorporated	41,804,884	57,360,509	69,019,232	42,161,655	210,346,280
Total	132,801,606	192,856,801	243,481,995	155,092,559	724,232,961
2003					
Homer	22,449,940	37,028,284	45,081,265	27,072,236	131,631,725
Kenai	31,093,476	29,801,554	31,351,738	29,065,451	121,312,219
Seldovia	598,970	962,966	1,140,319	674,689	3,376,944
Seward	9,289,341	22,079,581	34,709,882	10,296,934	76,375,738
Soldotna	34,463,622	47,018,649	62,576,271	46,558,340	190,616,882
KPB Unincorporated	38,385,673	58,170,580	69,988,679	42,993,899	209,538,831
Total	136,281,022	195,061,614	244,848,154	156,661,549	732,852,339
2004					
Homer	23,826,122	39,667,030	49,058,644	27,505,766	140,057,562
Kenai	29,545,991	36,254,870	40,032,554	32,794,031	138,627,446
Seldovia	566,726	939,589	1,182,138	693,229	3,381,682
Seward	9,493,481	22,986,031	37,075,050	10,374,949	79,929,511
Soldotna	37,383,328	49,010,429	66,182,951	47,473,561	200,050,269
KPB Unincorporated	39,081,187	58,211,025	75,403,970	45,351,061	218,047,243
Total	139,896,835	207,068,974	268,935,307	164,192,597	780,093,713
2005					
Year to Date					
Homer	23,444,569				23,444,569
Kenai	29,236,679				29,236,679
Seldovia	563,760				563,760
Seward	9,943,549				9,943,549
Soldotna	38,071,634				38,071,634
KPB Unincorporated	39,575,966				39,575,966
Total	140,836,157				140,836,157

Table 1.28

KPB Construction Permitting

Construction Permitting

Construction permits are not required within the KPB except within the incorporated cities - Homer, Kenai, Seldovia, Seward and Soldotna; therefore, data reported in this document does not include all construction activity. It does, however, provide the reader with borough trends. Permit Categories include Residential New (RN), Residential Alteration/Addition (RA), Commercial New (CN) and Commercial Alteration/Addition (CA). Individual cities may have other categories, but in an effort to provide consistent categories across the KPB, those categories have been combined into one of the four. Borough-wide new residential construction is presented in the annual statistical report, *Situations and Prospects*. Homer, Kenai, Seldovia and Soldotna permit activity has been recorded since 1986 but Seward did not require permits until 1988.

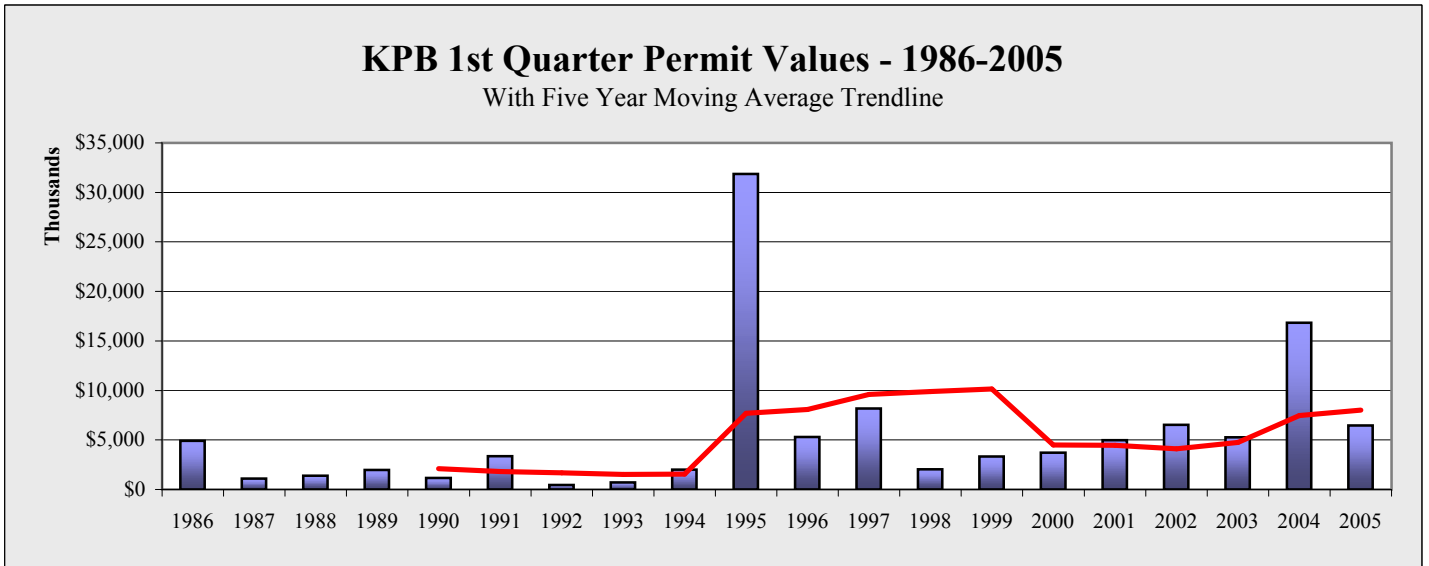

Chart 1.19

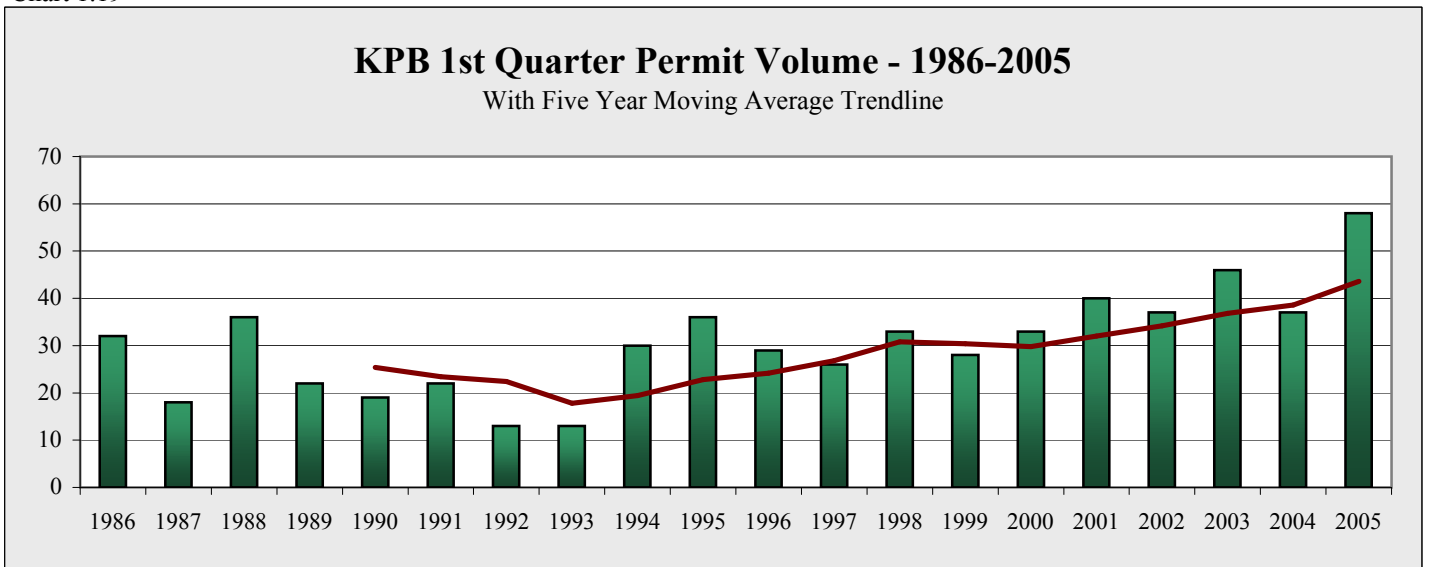

Chart 1.20

KPB 1st Quarter Permit Values by Area - 1999-2005 - in \$								
	1999	2000	2001	2002	2003	2004	2005	Annual Change
Homer	1,943,000	1,798,100	690,000	928,720	1,334,340	3,714,020	3,105,900	-16.4%
Kenai	239,500	462,900	819,500	3,888,200	1,557,600	312,000	425,500	36.4%
Seldovia	8,000	24,000	10,000	10,000	31,000	20,000	15,000	-25.0%
Seward	1,040,550	355,300	416,700	481,440	1,905,355	7,741,600	1,507,300	-80.5%
Soldotna	83,696	1,078,202	3,051,218	1,205,590	427,018	5,064,323	1,421,555	-71.9%
Total	3,314,746	3,718,502	4,987,418	6,513,950	5,255,313	16,851,943	6,475,255	-61.6%
Annual Change		12.2%	34.1%	30.6%	-19.3%	220.7%	-61.6%	

Table 1.29

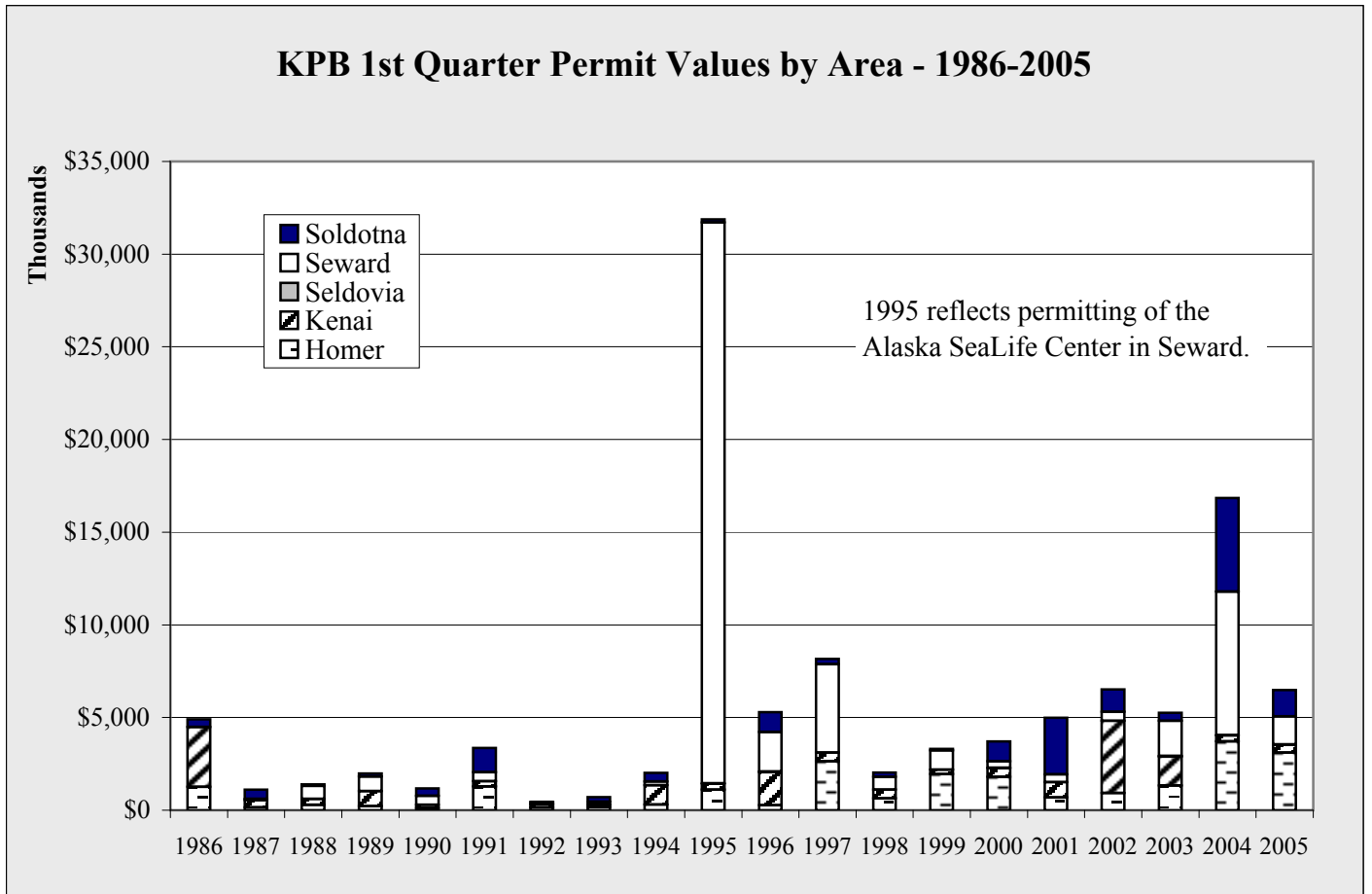

Chart 1.21

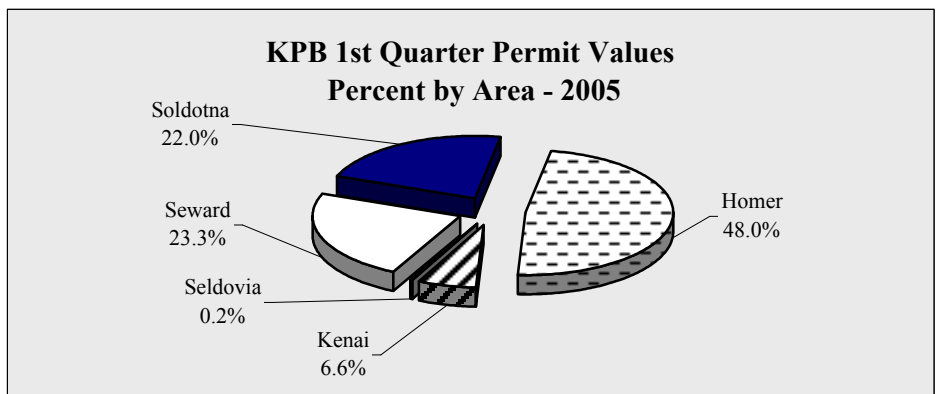

Chart 1.22

KPB 1st Quarter Permit Volume by Area - 1999-2005

	1999	2000	2001	2002	2003	2004	2005	Annual Change
Homer	5	9	7	10	18	16	18	12.5%
Kenai	7	8	11	5	8	4	10	150.0%
Seldovia	1	3	1	1	3	1	1	0.0%
Seward	5	5	11	10	11	7	13	85.7%
Soldotna	10	8	10	11	6	9	16	77.8%
Total	28	33	40	37	46	37	58	56.8%
Annual Change		17.9%	21.2%	-7.5%	24.3%	-19.6%	56.8%	

Table 1.30

KPB 1st Quarter Permit Volume by Area - 1986-2005

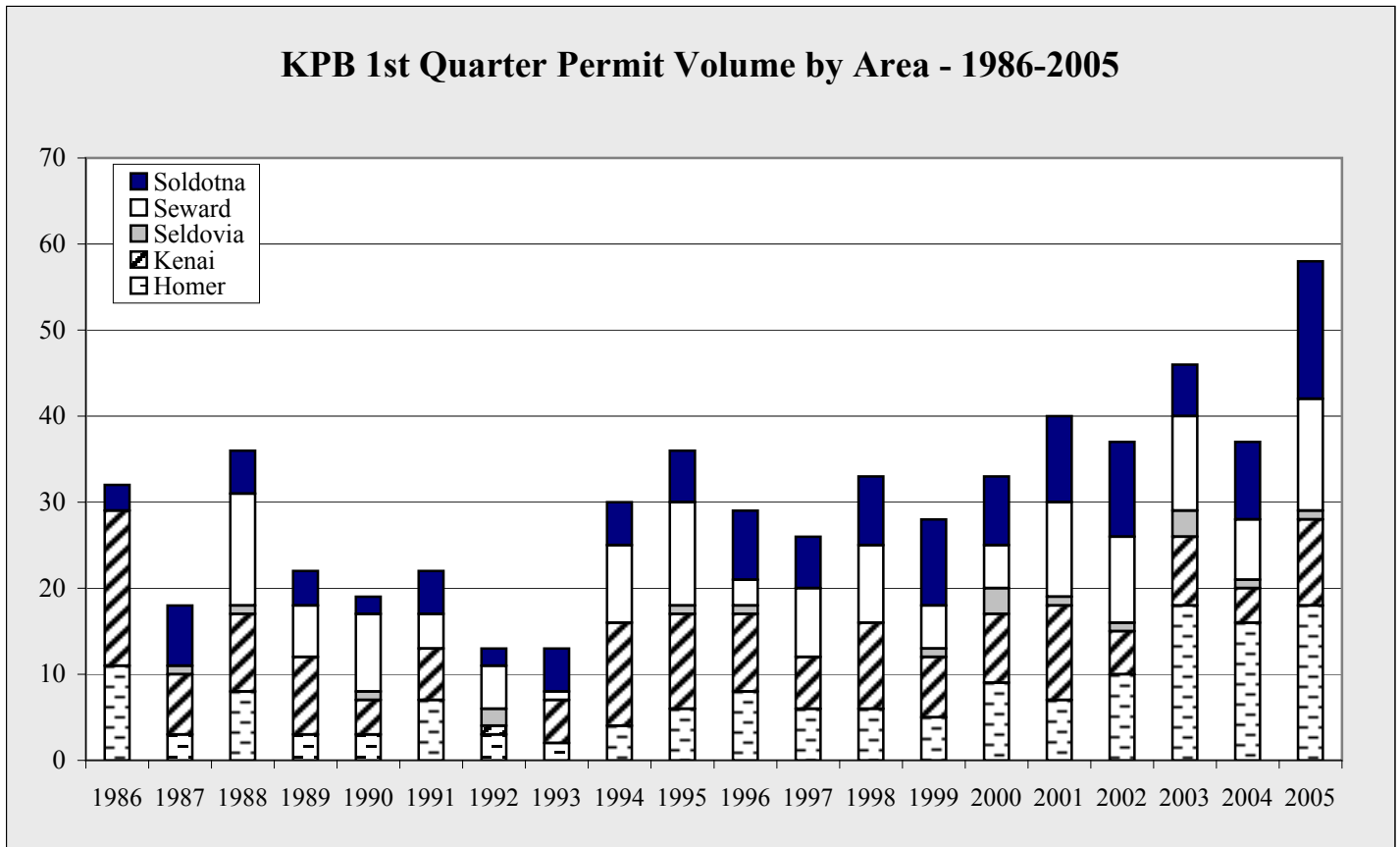

Chart 1.23

KPB 1st Quarter Permit Volume Percent by Area - 2005

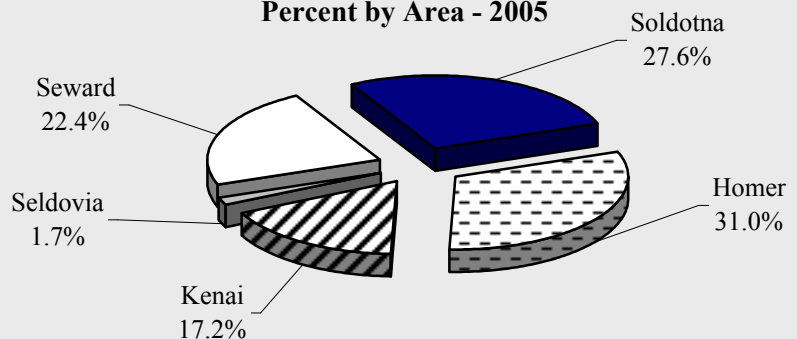

Chart 1.24

KPB 1st Quarter Permit Values by Type - 1999-2005 - in \$

	1999	2000	2001	2002	2003	2004	2005	Annual Change
Residential New	1,673,000	1,242,529	923,000	1,531,609	1,097,800	3,456,797	3,470,356	0.4%
Residential Alter/Add	181,200	18,500	356,860	159,391	393,867	261,520	418,930	60.2%
Commercial New	292,500	669,273	2,958,578	4,294,006	72,000	12,880,026	509,000	-96.0%
Commercial Alter/Add	1,168,046	1,788,200	748,980	528,944	3,691,646	253,600	2,076,969	719.0%
Total	3,314,746	3,718,502	4,987,418	6,513,950	5,255,313	16,851,943	6,475,255	-61.6%
Annual Change		12.2%	34.1%	30.6%	-19.3%	220.7%	-61.6%	

Table 1.31

KPB 1st Quarter Permit Values by Type - 1986-2005

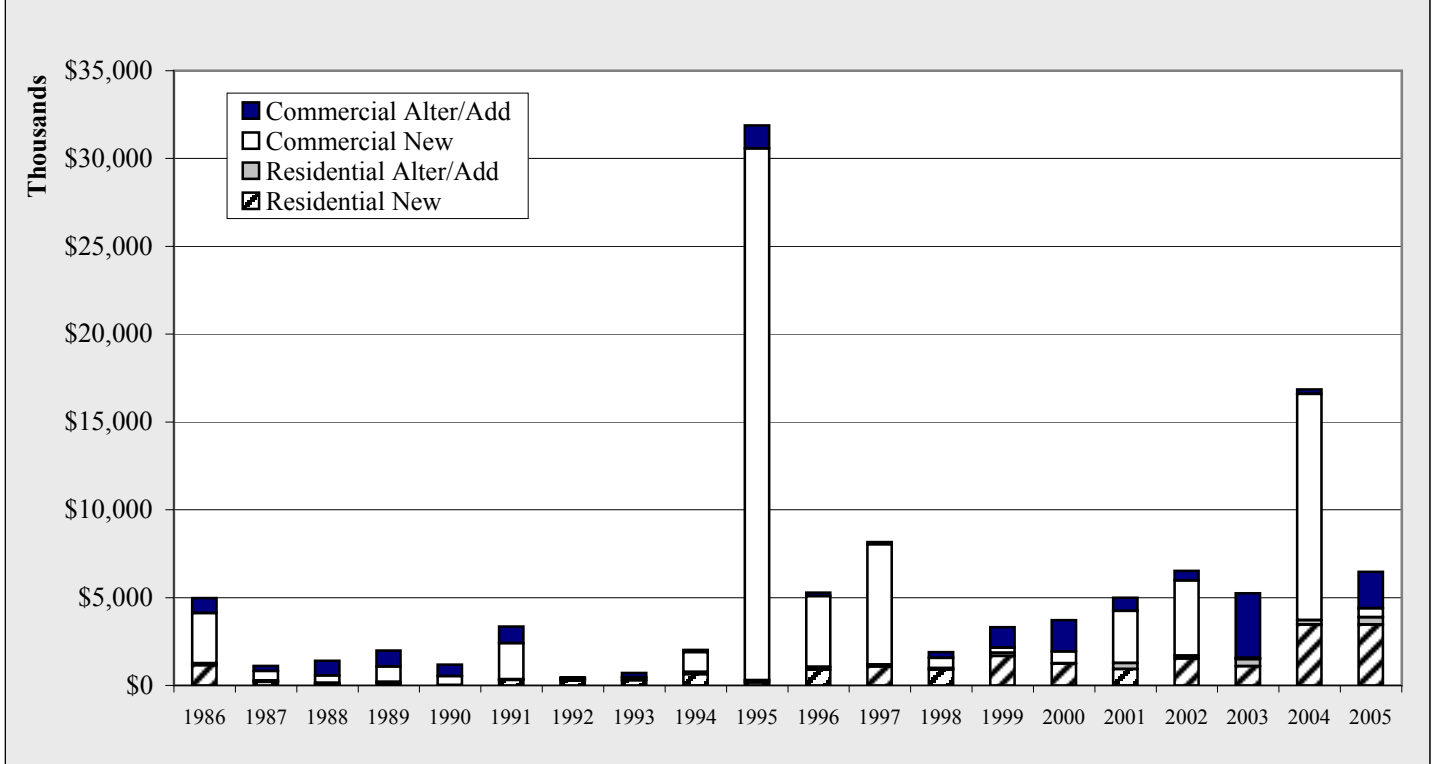

Chart 1.25

KPB 1st Quarter Permit Values - Percent by Type - 2005

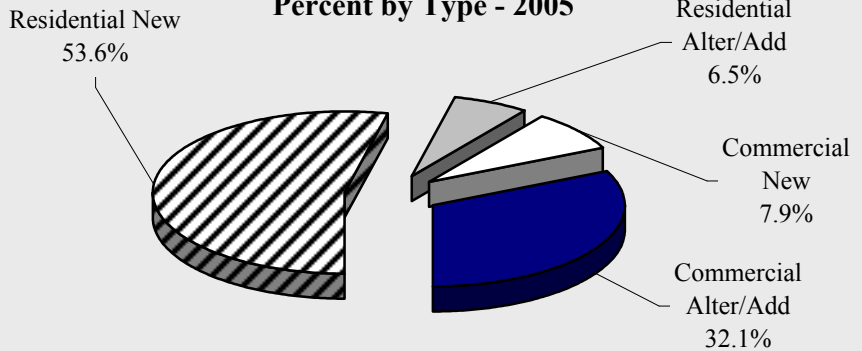

Chart 1.26

KPB Construction Permitting

KPB 1st Quarter Permit Volume by Type - 1999-2005

	1999	2000	2001	2002	2003	2004	2005	Annual Change
Residential New	3	10	7	12	7	17	18	5.9%
Residential Alter/Add	8	4	13	8	17	5	15	200.0%
Commercial New	4	4	6	5	1	7	6	-14.3%
Commercial Alter/Add	13	15	14	12	21	8	19	137.5%
Total	28	33	40	37	46	37	58	56.8%
Annual Change		17.9%	21.2%	-7.5%	24.3%	-19.6%	56.8%	

Table 1.32

KPB 1st Quarter Permit Volume by Type - 1986-2005

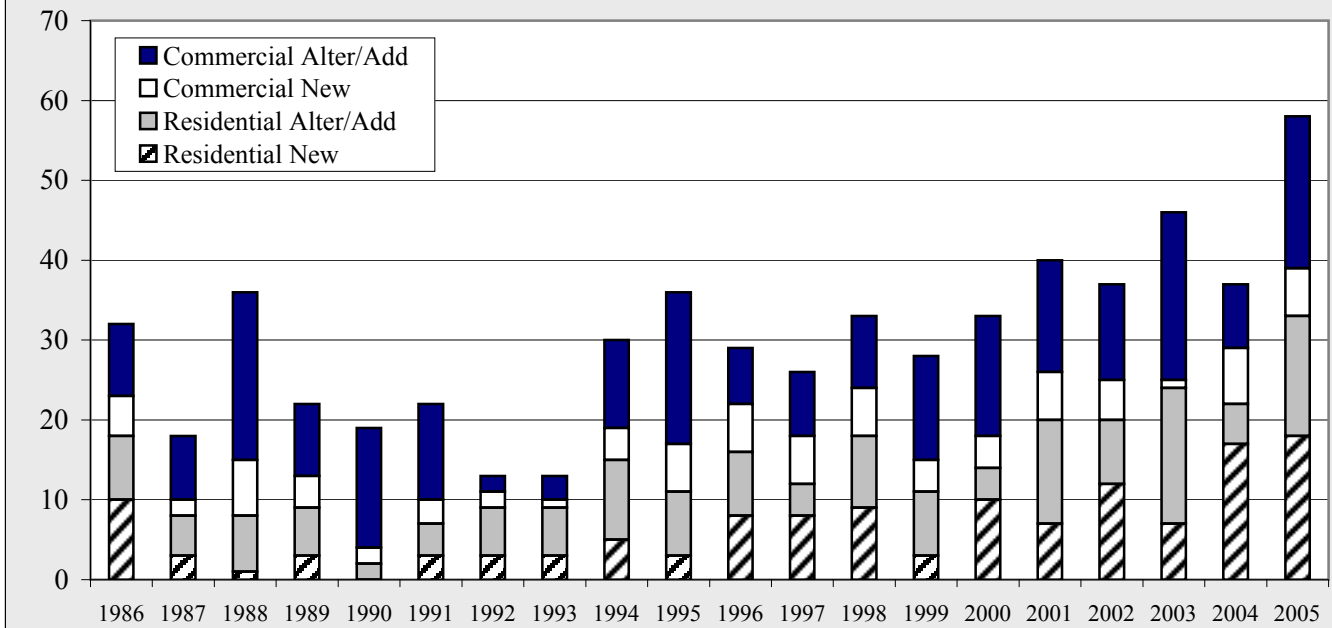

Chart 1.27

KPB 1st Quarter Permit Volume - Percent by Type - 2005

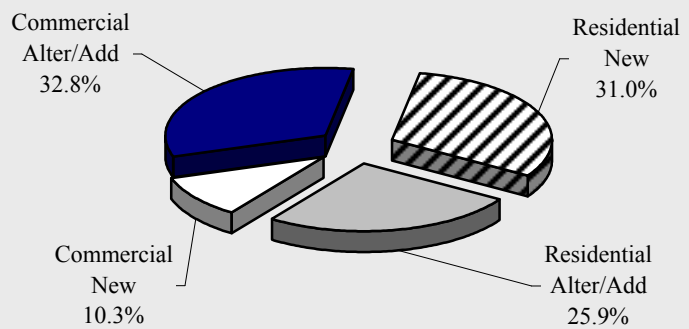

Chart 1.28

KPB Annual Permit Values by Area- 1998-2004 - in \$								
	1998	1999	2000	2001	2002	2003	2004	Annual Change
Homer	6,199,875	10,940,000	7,128,972	19,800,690	10,048,779	15,326,815	24,070,631	57.0%
Kenai	7,642,200	9,441,750	9,398,100	13,578,900	16,799,400	10,441,800	4,786,550	-54.2%
Seldovia	0	479,000	109,200	65,525	356,500	1,902,500	176,200	-90.7%
Seward	6,747,861	4,241,413	3,451,565	2,716,981	7,910,703	7,982,765	17,711,150	121.9%
Soldotna	9,621,817	9,505,120	8,167,420	8,954,972	11,163,894	7,952,297	37,296,926	369.0%
Total	30,211,753	34,607,283	28,255,257	45,117,068	46,279,276	43,606,177	84,041,457	92.7%
Annual Change		14.5%	-18.4%	59.7%	2.6%	-5.8%	92.7%	

Table 1.33

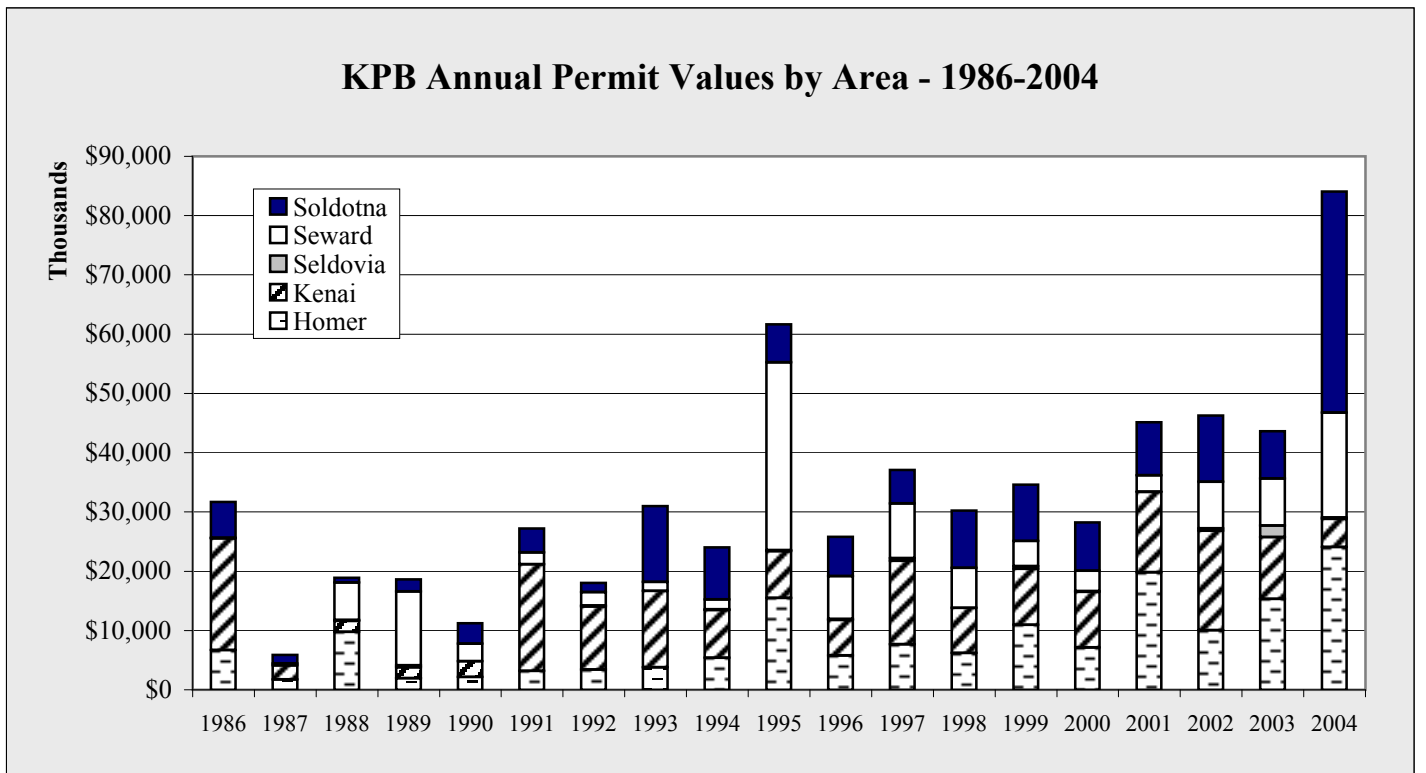

Chart 1.29

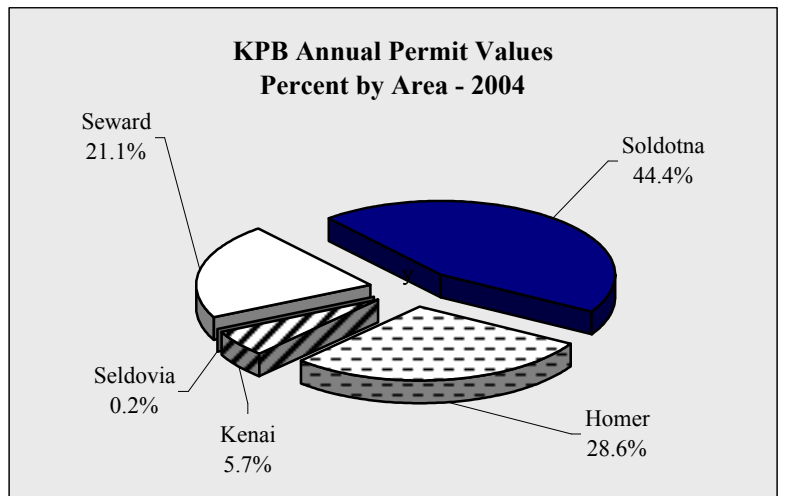

Chart 1.30

KPB Annual Permit Volume by Area- 1998-2004								
	1998	1999	2000	2001	2002	2003	2004	Annual Change
Homer	48	52	58	72	67	86	108	25.6%
Kenai	97	102	93	87	121	114	79	-30.7%
Seldovia	0	20	13	9	8	12	4	-66.7%
Seward	49	56	51	48	64	50	54	8.0%
Soldotna	77	77	88	93	91	74	67	-9.5%
Total	271	307	303	309	351	336	312	-7.1%
Annual Change		13.3%	-1.3%	2.0%	13.6%	-4.3%	-7.1%	

Table 1.34

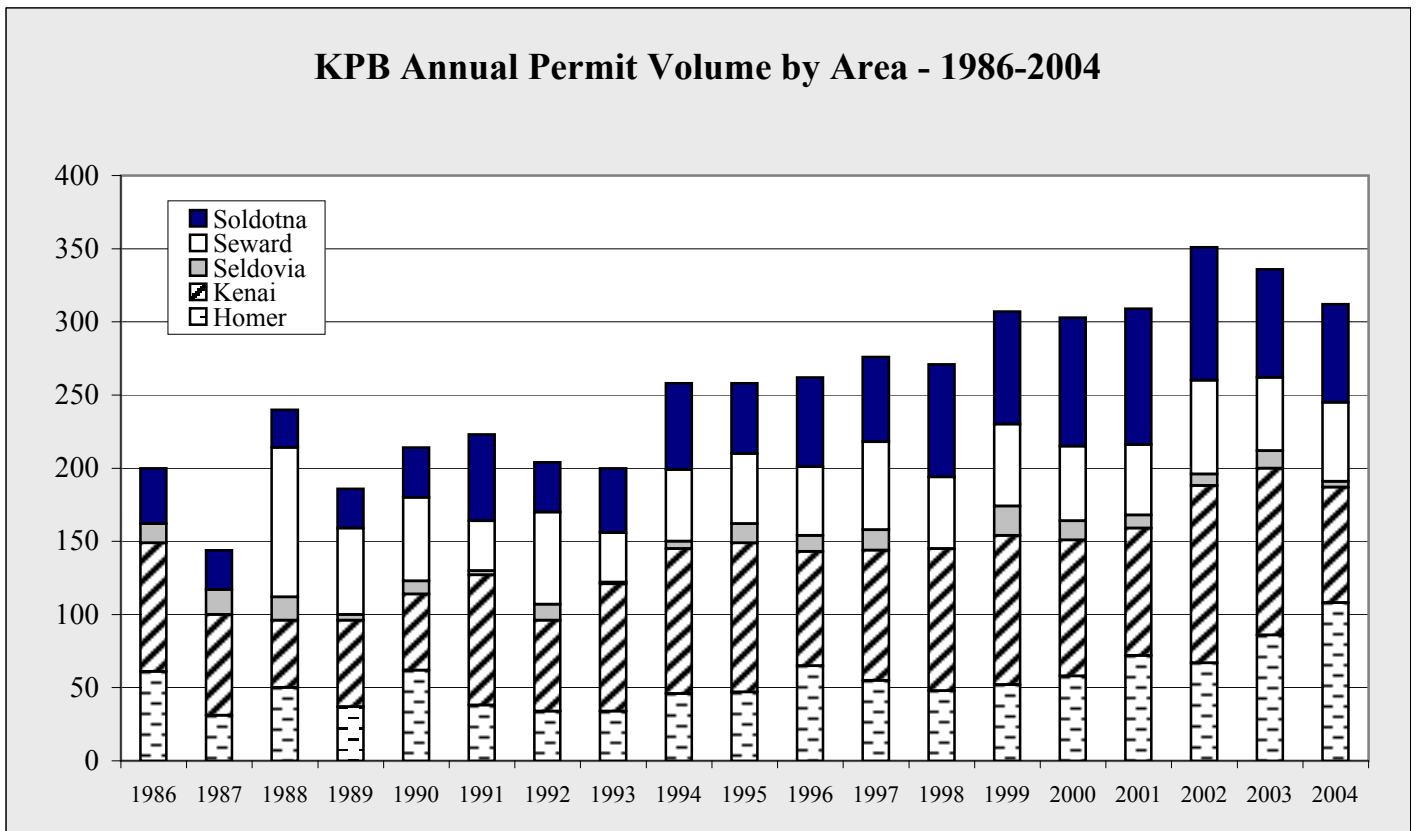

Chart 1.31

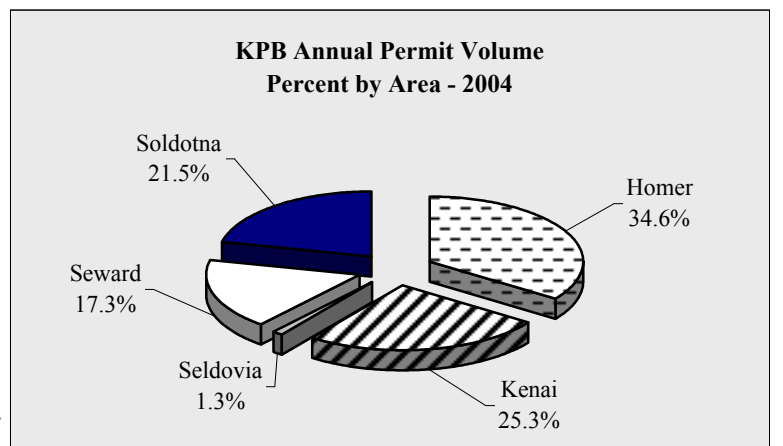

Chart 1.32

KPB Construction Permittives

KPB Annual Permit Values by Type - 1998-2004- in \$

	1998	1999	2000	2001	2002	2003	2004	Annual Change
Residential New	12,376,250	11,395,862	9,885,058	13,391,633	14,358,064	15,729,888	15,935,344	1.3%
Residential Alter/Add	1,747,903	1,834,828	1,990,399	1,996,494	2,305,815	2,280,779	2,880,284	26.3%
Commercial New	13,494,922	18,862,564	10,662,544	11,565,350	21,793,729	15,820,201	56,079,343	254.5%
Commercial Alter/Add	2,592,678	2,514,029	5,717,256	18,163,591	7,821,668	9,775,309	9,146,486	-6.4%
Total	30,211,753	34,607,283	28,255,257	45,117,068	46,279,276	43,606,177	84,041,457	92.7%
Annual Change		14.5%	-18.4%	59.7%	2.6%	-5.8%	92.7%	

Table 1.35

KPB Annual Permit Values by Type - 1986-2004

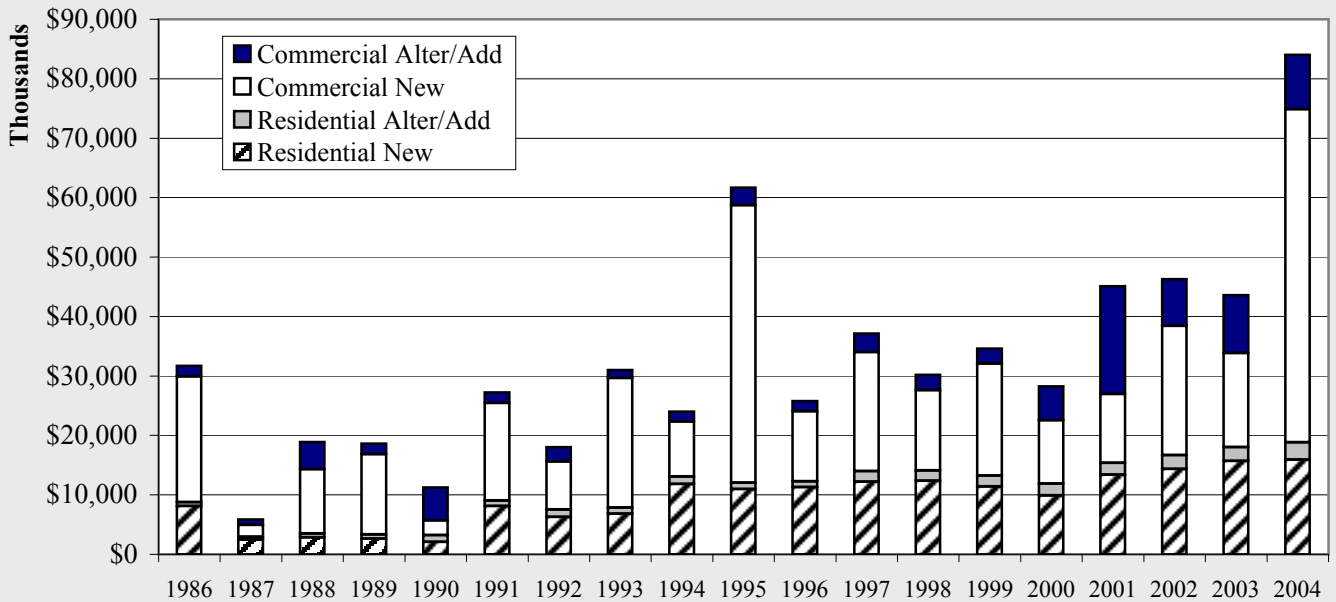

Chart 1.33

KPB Annual Permit Values Percent by Type - 2004

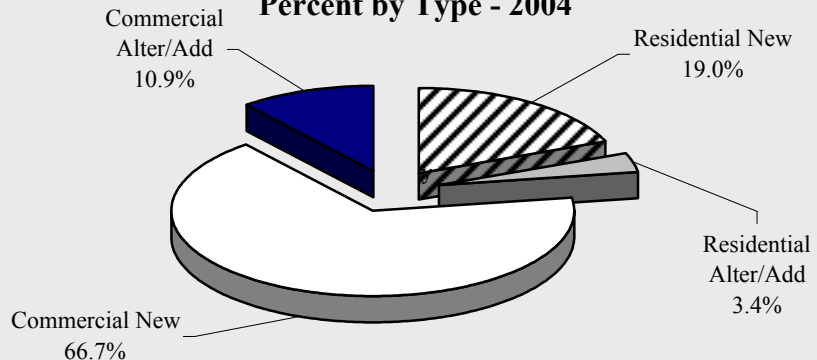

Chart 1.34

KPB Construction Permittives

KPB Annual Permit Volume by Type - 1998-2004

	1998	1999	2000	2001	2002	2003	2004	Annual Change
Residential New	92	79	79	89	104	104	94	-9.6%
Residential Alter/Add	78	98	97	96	116	94	96	2.1%
Commercial New	48	57	45	32	43	42	42	0.0%
Commercial Alter/Add	53	73	82	92	88	96	80	-16.7%
Total	271	307	303	309	351	336	312	-7.1%
Annual Change		13.3%	-1.3%	2.0%	13.6%	-4.3%	-7.1%	

Table 1.36

KPB Annual Permit Volume by Type - 1986-2004

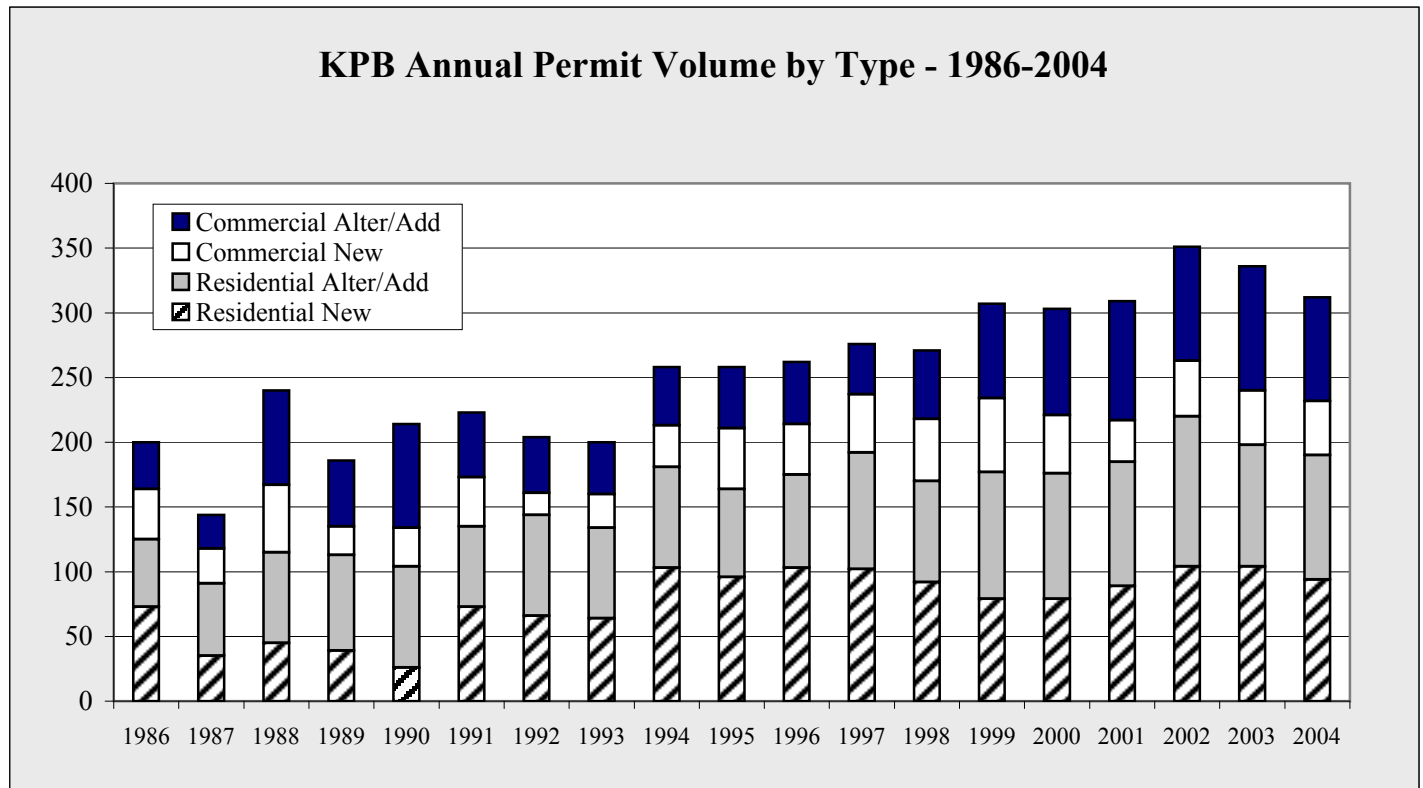

Chart 1.35

KPB Annual Permit Volume Percent by Type - 2004

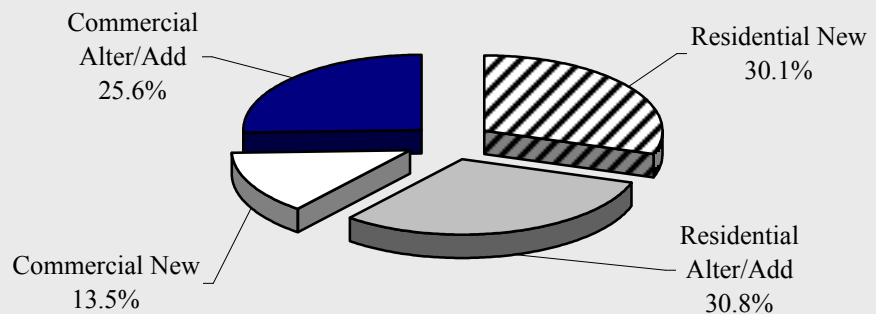

Chart 1.36

KPB Construction Permit Values by Type, Quarter - 1998-2005 - in \$					
	1st Quarter	2nd Quarter	3rd Quarter	4th Quarter	Total
1998					
Residential - New	887,500	6,367,500	3,623,500	1,352,750	12,376,250
Residential - Add/Alter	93,543	879,900	539,500	234,960	1,747,903
Commercial - New	585,754	3,600,436	7,440,732	1,868,000	13,494,922
Commercial - Add/Alter	321,842	280,000	1,586,736	404,100	2,592,678
TOTAL	2,033,639	11,127,836	13,190,468	3,859,810	30,211,753
1999					
Residential - New	1,673,000	4,754,674	3,722,300	1,245,888	11,395,862
Residential - Add/Alter	181,200	667,961	694,267	291,400	1,834,828
Commercial - New	292,500	4,798,818	12,808,341	962,905	18,862,564
Commercial - Add/Alter	1,168,046	724,813	472,570	148,600	2,514,029
TOTAL	3,314,746	10,946,266	17,697,478	2,648,793	34,607,283
2000					
Residential - New	1,242,529	4,531,931	3,137,930	972,668	9,885,058
Residential - Add/Alter	18,500	860,574	672,025	439,300	1,990,399
Commercial - New	669,273	3,564,122	4,966,665	1,462,484	10,662,544
Commercial - Add/Alter	1,788,200	2,269,349	910,625	749,082	5,717,256
TOTAL	3,718,502	11,225,976	9,687,245	3,623,534	28,255,257
2001					
Residential - New	923,000	7,367,801	3,984,532	1,116,300	13,391,633
Residential - Add/Alter	356,860	758,779	531,907	348,948	1,996,494
Commercial - New	2,958,578	5,384,800	2,707,972	514,000	11,565,350
Commercial - Add/Alter	748,980	2,110,989	3,445,622	11,858,000	18,163,591
TOTAL	4,987,418	15,622,369	10,670,033	13,837,248	45,117,068
2002					
Residential - New	1,531,609	6,145,753	5,567,502	1,113,200	14,358,064
Residential - Add/Alter	159,391	1,044,943	875,861	225,620	2,305,815
Commercial - New	4,294,006	8,376,305	5,955,418	3,168,000	21,793,729
Commercial - Add/Alter	528,944	2,430,953	4,515,971	345,800	7,821,668
TOTAL	6,513,950	17,997,954	16,914,752	4,852,620	46,279,276
2003					
Residential - New	1,097,800	7,868,834	4,209,163	2,554,091	15,729,888
Residential - Add/Alter	393,867	984,340	611,572	291,000	2,280,779
Commercial - New	72,000	8,965,210	4,636,000	2,146,991	15,820,201
Commercial - Add/Alter	3,691,646	745,400	3,349,900	1,988,363	9,775,309
TOTAL	5,255,313	18,563,784	12,806,635	6,980,445	43,606,177
2004					
Residential - New	3,456,797	6,374,487	4,950,200	1,153,860	15,935,344
Residential - Add/Alter	261,520	483,839	1,605,471	529,454	2,880,284
Commercial - New	12,880,026	11,147,815	28,989,901	3,061,601	56,079,343
Commercial - Add/Alter	253,600	2,673,643	2,024,493	4,194,750	9,146,486
TOTAL	16,851,943	20,679,784	37,570,065	8,939,665	84,041,457
2005					
					Year to Date
Residential - New	3,470,356				3,470,356
Residential - Add/Alter	418,930				418,930
Commercial - New	509,000				509,000
Commercial - Add/Alter	2,076,969				2,076,969
TOTAL	6,475,255				6,475,255

Table 1.37

KPB Construction Permit Volume by Type, Quarter - 1998-2005					
	1st Quarter	2nd Quarter	3rd Quarter	4th Quarter	Total
1998					
Residential - New	9	45	28	10	92
Residential - Add/Alter	9	24	28	17	78
Commercial - New	6	19	17	6	48
Commercial - Add/Alter	9	16	12	16	53
TOTAL	33	104	85	49	271
1999					
Residential - New	3	38	25	13	79
Residential - Add/Alter	8	36	36	18	98
Commercial - New	4	20	24	9	57
Commercial - Add/Alter	13	22	28	10	73
TOTAL	28	116	113	50	307
2000					
Residential - New	10	32	28	9	79
Residential - Add/Alter	4	38	40	15	97
Commercial - New	4	13	16	12	45
Commercial - Add/Alter	15	30	22	15	82
TOTAL	33	113	106	51	303
2001					
Residential - New	7	45	29	8	89
Residential - Add/Alter	13	38	31	14	96
Commercial - New	6	9	15	2	32
Commercial - Add/Alter	14	36	24	18	92
TOTAL	40	128	99	42	309
2002					
Residential - New	12	45	38	9	104
Residential - Add/Alter	8	42	49	17	116
Commercial - New	5	17	14	7	43
Commercial - Add/Alter	12	32	28	16	88
TOTAL	37	136	129	49	351
2003					
Residential - New	7	47	28	22	104
Residential - Add/Alter	17	33	34	10	94
Commercial - New	1	17	17	7	42
Commercial - Add/Alter	21	26	26	23	96
TOTAL	46	123	105	62	336
2004					
Residential - New	17	34	32	11	94
Residential - Add/Alter	5	30	44	17	96
Commercial - New	7	11	15	9	42
Commercial - Add/Alter	8	31	25	16	80
TOTAL	37	106	116	53	312
2005 Year to Date					
Residential - New	18				18
Residential - Add/Alter	15				15
Commercial - New	6				6
Commercial - Add/Alter	19				19
TOTAL	58				58

Table 1.38

KPB Construction Permitting

KPB Construction Permit Values by Area, Quarter - 1999-2005 - in \$					
	1st Quarter	2nd Quarter	3rd Quarter	4th Quarter	Total
1999					
Homer	1,943,000	2,691,000	5,745,000	561,000	10,940,000
Kenai	239,500	2,022,600	6,122,650	1,057,000	9,441,750
Seldovia	8,000	365,500	87,500	18,000	479,000
Seward	1,040,550	1,082,114	1,615,749	503,000	4,241,413
Soldotna	83,696	4,785,052	4,126,579	509,793	9,505,120
TOTAL	3,314,746	10,946,266	17,697,478	2,648,793	34,607,283
2000					
Homer	1,798,100	2,265,920	2,146,970	917,982	7,128,972
Kenai	462,900	3,163,000	5,094,000	678,200	9,398,100
Seldovia	24,000	22,300	57,900	5,000	109,200
Seward	355,300	1,765,400	711,465	619,400	3,451,565
Soldotna	1,078,202	4,009,356	1,676,910	1,402,952	8,167,420
TOTAL	3,718,502	11,225,976	9,687,245	3,623,534	28,255,257
2001					
Homer	690,000	4,102,040	2,996,350	12,012,300	19,800,690
Kenai	819,500	7,597,900	4,506,200	655,300	13,578,900
Seldovia	10,000	25,000	15,525	15,000	65,525
Seward	416,700	666,239	642,042	992,000	2,716,981
Soldotna	3,051,218	3,231,190	2,509,916	162,648	8,954,972
TOTAL	4,987,418	15,622,369	10,670,033	13,837,248	45,117,068
2002					
Homer	928,720	2,528,209	5,777,330	814,520	10,048,779
Kenai	3,888,200	4,569,400	6,814,000	1,527,800	16,799,400
Seldovia	10,000	8,000	318,500	20,000	356,500
Seward	481,440	3,888,887	1,307,576	2,232,800	7,910,703
Soldotna	1,205,590	7,003,458	2,697,346	257,500	11,163,894
TOTAL	6,513,950	17,997,954	16,914,752	4,852,620	46,279,276
2003					
Homer	1,334,340	7,929,500	3,020,075	3,042,900	15,326,815
Kenai	1,557,600	2,728,350	3,700,350	2,455,500	10,441,800
Seldovia	31,000	0	1,835,000	36,500	1,902,500
Seward	1,905,355	3,672,010	1,832,900	572,500	7,982,765
Soldotna	427,018	4,233,924	2,418,310	873,045	7,952,297
TOTAL	5,255,313	18,563,784	12,806,635	6,980,445	43,606,177
2004					
Homer	3,714,020	7,433,711	9,531,900	3,391,000	24,070,631
Kenai	312,000	1,897,400	1,991,750	585,400	4,786,550
Seldovia	20,000	156,200	0	0	176,200
Seward	7,741,600	7,443,900	2,266,300	259,350	17,711,150
Soldotna	5,064,323	3,748,573	23,780,115	4,703,915	37,296,926
TOTAL	16,851,943	20,679,784	37,570,065	8,939,665	84,041,457
2005					
Year to Date					
Homer	3,105,900				3,105,900
Kenai	425,500				425,500
Seldovia	15,000				15,000
Seward	1,507,300				1,507,300
Soldotna	1,421,555				1,421,555
TOTAL	6,475,255				6,475,255

Table 1.39

KPB Construction Permitting KPB Construction Permit Volume by Area, Quarter - 1999-2005

	1st Quarter	2nd Quarter	3rd Quarter	4th Quarter	Total
1999					
Homer	5	21	20	6	52
Kenai	7	33	40	22	102
Seldovia	1	9	7	3	20
Seward	5	18	23	10	56
Soldotna	10	35	23	9	77
TOTAL	28	116	113	50	307
2000					
Homer	9	20	21	8	58
Kenai	8	36	36	13	93
Seldovia	3	3	6	1	13
Seward	5	20	17	9	51
Soldotna	8	34	26	20	88
TOTAL	33	113	106	51	303
2001					
Homer	7	34	22	9	72
Kenai	11	42	23	11	87
Seldovia	1	1	5	2	9
Seward	11	14	14	9	48
Soldotna	10	37	35	11	93
TOTAL	40	128	99	42	309
2002					
Homer	10	17	27	13	67
Kenai	5	37	59	20	121
Seldovia	1	2	4	1	8
Seward	10	29	14	11	64
Soldotna	11	51	25	4	91
TOTAL	37	136	129	49	351
2003					
Homer	18	34	21	13	86
Kenai	8	40	45	21	114
Seldovia	3	0	5	4	12
Seward	11	13	15	11	50
Soldotna	6	36	19	13	74
TOTAL	46	123	105	62	336
2004					
Homer	16	26	42	24	108
Kenai	4	30	31	14	79
Seldovia	1	3	0	0	4
Seward	7	21	19	7	54
Soldotna	9	26	24	8	67
TOTAL	37	106	116	53	312
2005					
	Year to Date				
Homer	18				18
Kenai	10				10
Seldovia	1				1
Seward	13				13
Soldotna	16				16
TOTAL	58				58

Table 1.40

KPB Employment

Employment data are acquired from the Alaska Department of Labor and Workforce Development (AK DOLWD) as reported by each business.

Government employees include federal, state, borough and local government as well as public school and state university employees. Employees of both Central Peninsula General Hospital in Soldotna and South Peninsula General Hospital in Homer are included in government data rather than service data because they are owned by and receive funds from the KPB.

The AK DOLWD updates employment data regularly. Self-employed workers, fishers, domestics, unpaid family help, most individuals engaged in agriculture and some other smaller worker groups are excluded from these figures due to exemption from certain reporting requirements.

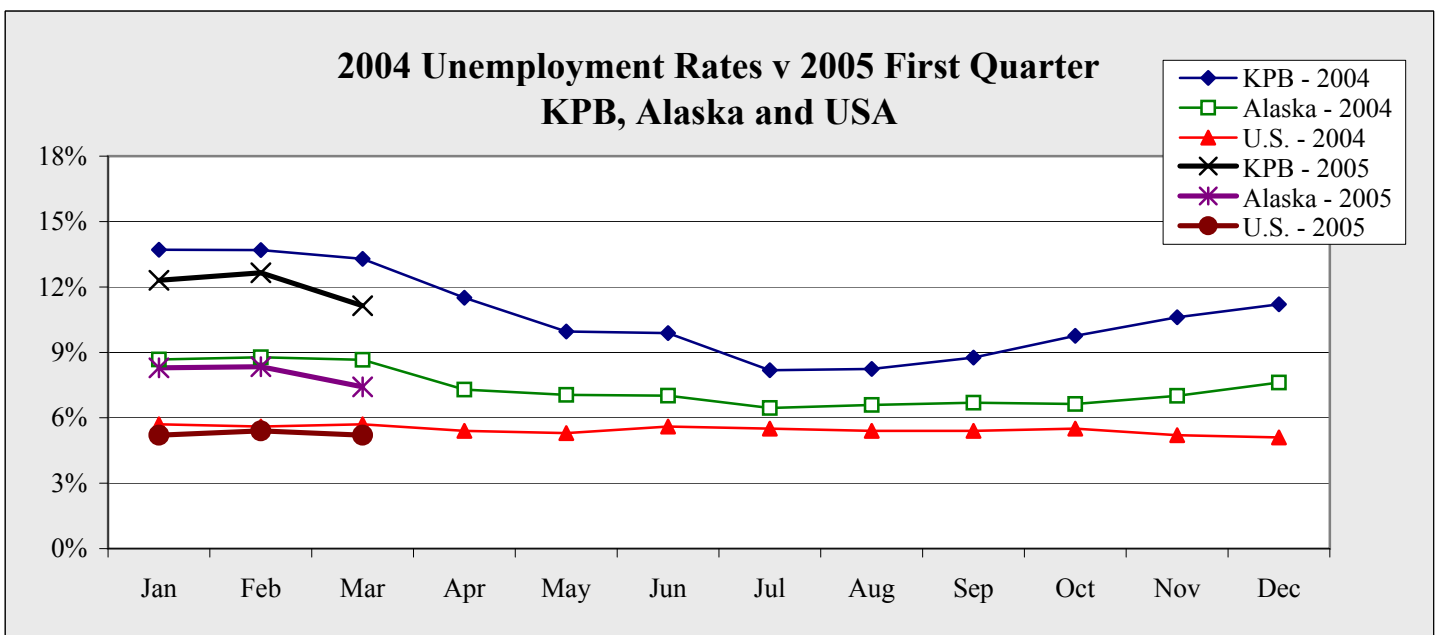

Chart 1.37

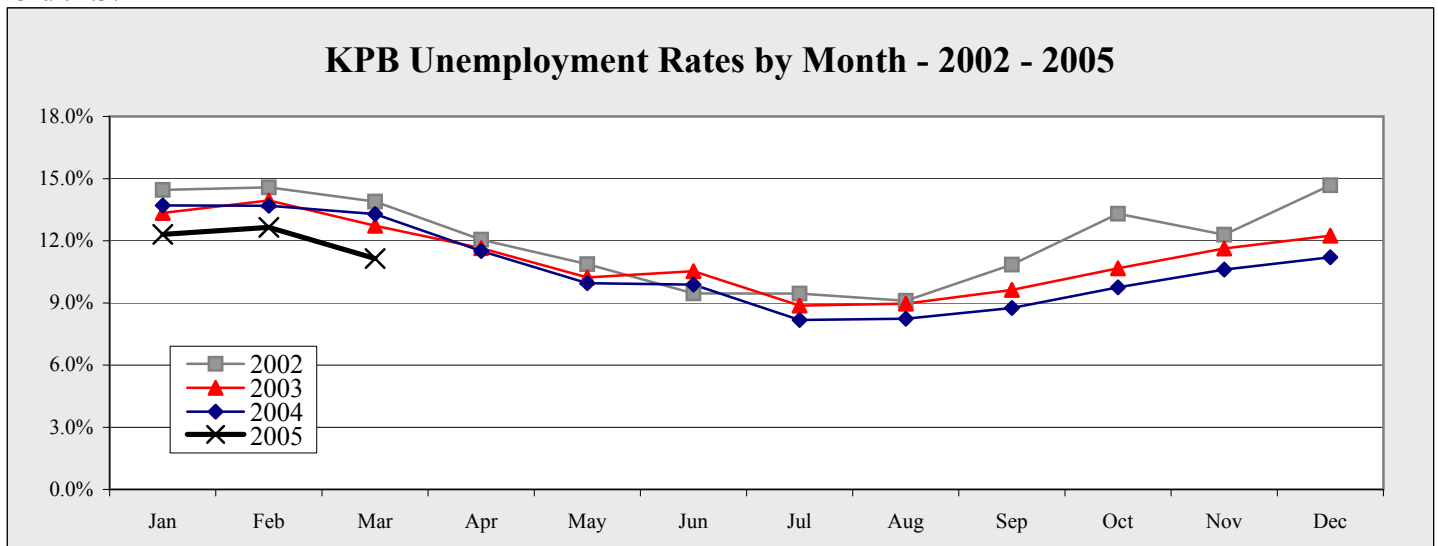

Chart 1.38

KPB Employment

KPB Labor Force by Month - 1990-2005

	Jan	Feb	Mar	Apr	May	Jun	Jul	Aug	Sep	Oct	Nov	Dec	Avg
1990	17,484	17,834	17,907	18,562	19,163	20,281	21,497	20,995	18,632	18,592	18,087	17,804	18,903
1991	18,314	18,612	18,738	19,469	19,806	20,852	22,525	21,608	19,981	19,045	18,919	18,574	19,704
1992	18,749	19,468	19,366	19,734	20,218	22,206	22,766	21,409	20,614	20,300	19,409	19,138	20,281
1993	18,526	19,509	19,827	20,175	20,457	22,835	24,085	23,031	20,626	20,550	19,792	19,293	20,726
1994	19,602	21,104	21,193	20,557	21,046	23,263	24,611	23,372	21,078	20,922	20,057	19,392	21,350
1995	20,603	21,179	20,971	20,505	21,100	22,740	24,340	23,498	21,559	21,432	20,441	19,915	21,524
1996	20,902	21,795	21,739	21,609	22,651	24,000	25,583	24,841	23,228	21,906	21,335	20,561	22,513
1997	21,742	22,421	21,898	21,993	22,076	24,208	25,480	24,414	22,467	21,325	20,589	19,953	22,381
1998	20,677	20,713	20,426	20,395	21,346	23,475	24,773	24,319	22,567	21,208	20,112	19,520	21,628
1999	20,429	21,171	20,932	21,048	21,466	23,076	24,114	23,381	22,244	21,096	20,202	19,727	21,574
2000	20,787	21,091	21,041	21,077	22,115	23,940	23,783	23,616	22,627	21,686	21,670	21,769	21,736
2001	20,807	20,784	20,821	20,865	21,789	23,496	24,134	23,057	22,045	21,353	21,307	21,454	21,676
2002	20,596	20,969	21,108	21,305	21,893	22,863	24,201	23,601	22,099	20,554	21,261	20,446	21,741
2003	21,974	21,827	21,925	22,025	22,923	24,172	24,489	23,759	22,176	21,684	21,660	21,565	22,515
2004	21,566	21,684	21,798	21,795	22,825	24,468	24,850	23,746	22,504	21,821	21,756	21,679	22,541
2005	21,856	21,841	21,980										

Table 1.41

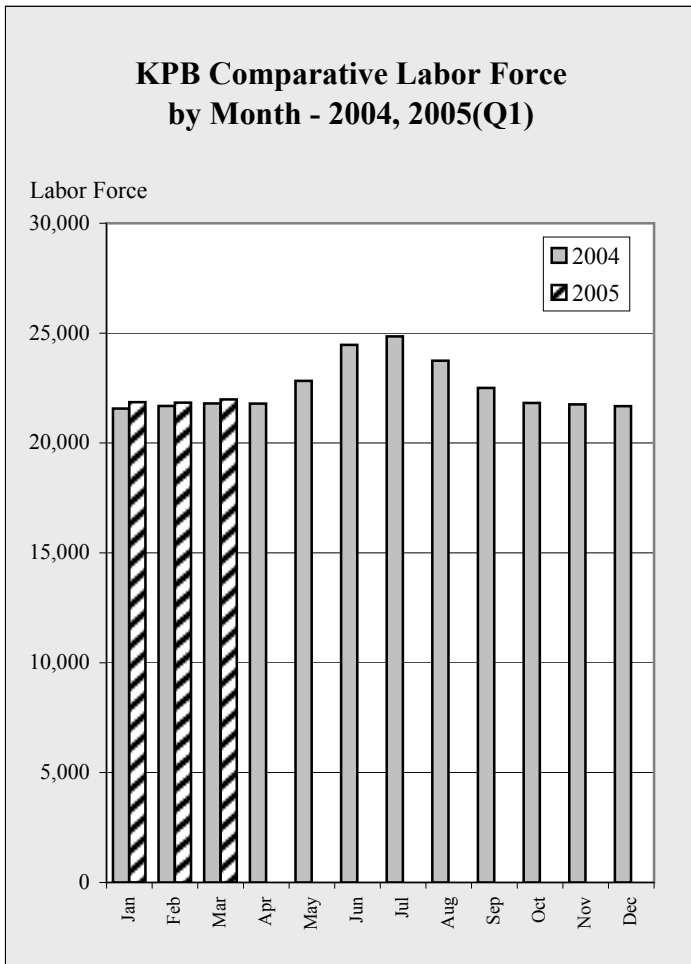

Chart 1.39



Chart 1.40

KPB Employment

KPB Unemployment by Month - 1990-2005

	Jan	Feb	Mar	Apr	May	Jun	Jul	Aug	Sep	Oct	Nov	Dec	Avg
1990	2,684	2,671	2,451	2,321	2,117	1,969	1,651	1,733	1,925	2,384	2,331	2,311	2,212
1991	2,894	2,960	2,769	2,635	2,383	2,381	2,179	2,045	2,203	2,900	3,398	3,523	2,689
1992	4,173	4,388	3,776	3,435	3,081	3,050	2,510	2,004	2,233	2,971	2,983	3,056	3,138
1993	3,644	3,816	3,341	3,084	2,594	2,483	1,949	1,695	1,724	2,507	2,641	2,686	2,680
1994	3,397	3,634	3,282	2,933	2,617	2,516	2,390	1,920	1,819	2,688	2,546	2,753	2,708
1995	3,589	3,623	3,143	2,650	2,238	2,238	2,137	1,863	1,864	2,717	2,807	2,966	2,653
1996	3,749	3,987	3,409	3,163	2,939	2,768	2,555	2,145	2,651	3,293	3,578	3,524	3,147
1997	4,456	4,487	3,849	3,369	2,778	2,814	2,390	1,984	2,093	2,706	2,775	2,667	3,031
1998	3,009	2,973	2,531	2,141	1,855	2,075	1,657	1,371	1,630	2,062	1,994	2,092	2,116
1999	2,921	3,445	2,897	2,519	2,229	2,256	1,994	1,742	1,885	2,198	2,252	2,197	2,378
2000	2,530	2,575	2,445	2,138	1,943	1,843	1,546	1,556	1,496	1,671	1,871	2,019	1,969
2001	2,326	2,378	2,276	2,044	1,767	1,810	1,545	1,561	1,561	1,756	1,965	2,180	1,931
2002	2,978	3,057	2,932	2,568	2,380	2,162	2,288	2,148	2,397	2,735	2,614	3,001	2,605
2003	2,932	3,044	2,790	2,564	2,346	2,546	2,172	2,130	2,135	2,314	2,519	2,641	2,511
2004	2,956	2,969	2,897	2,508	2,272	2,419	2,033	1,956	1,971	2,129	2,309	2,429	2,404
2005	2,690	2,763	2,449										

Table 1.42

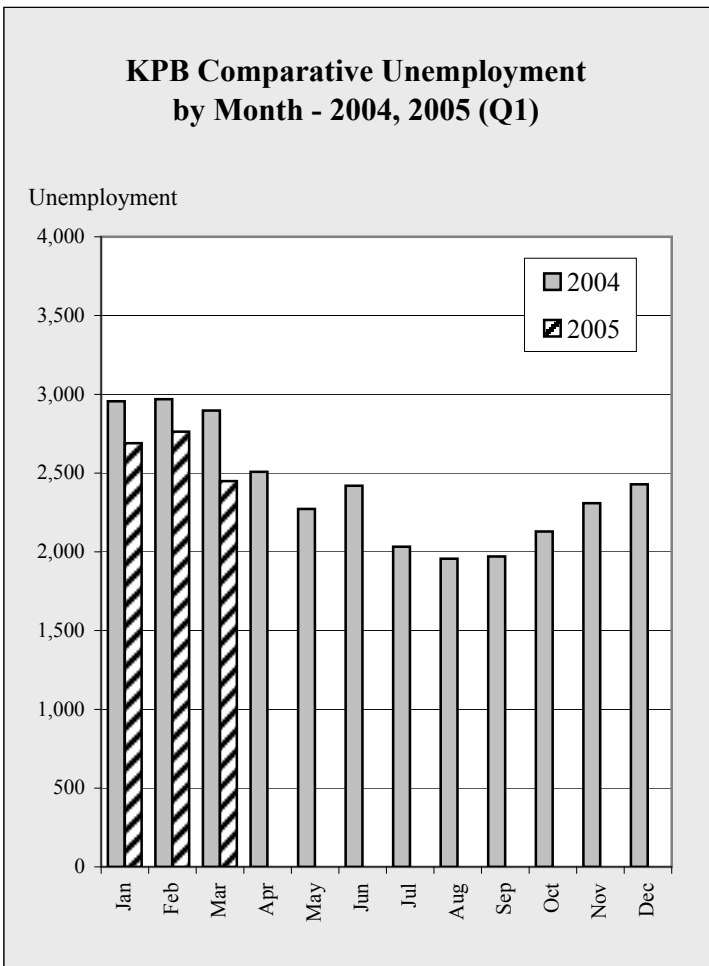

Chart 1.41

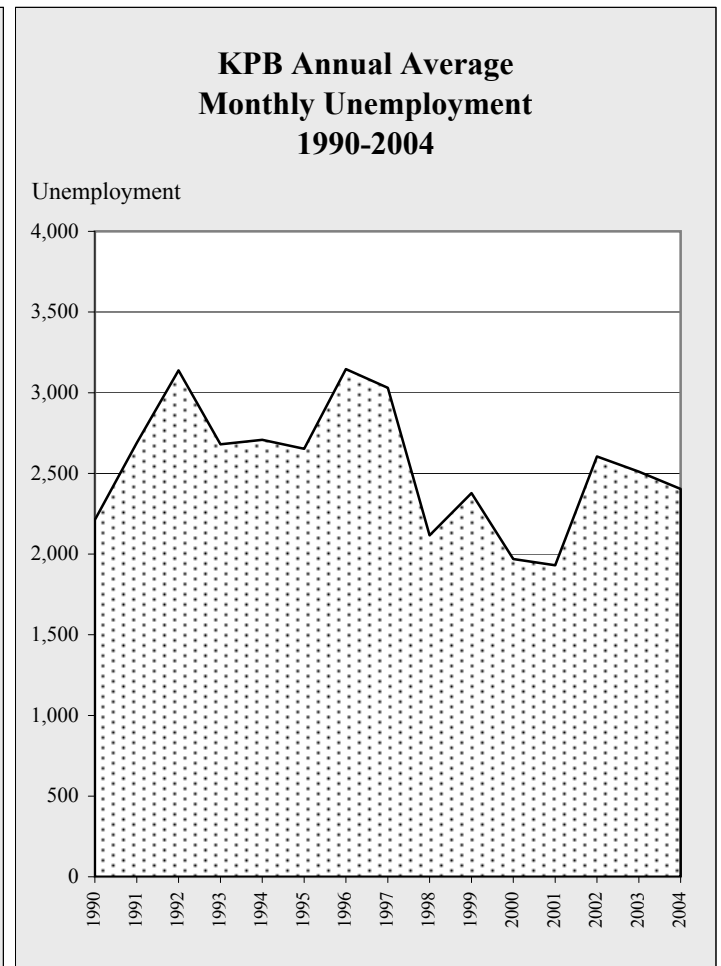

Chart 1.42

KPB Employment

KPB Unemployment Rates by Month - 1990-2005

	Jan	Feb	Mar	Apr	May	Jun	Jul	Aug	Sep	Oct	Nov	Dec	Avg
1990	15.4%	15.0%	13.7%	12.5%	11.0%	9.7%	7.7%	8.3%	10.3%	12.8%	12.9%	13.0%	11.9%
1991	15.8%	15.9%	14.8%	13.5%	12.0%	11.4%	9.7%	9.5%	11.0%	15.2%	18.0%	19.0%	13.8%
1992	22.3%	22.5%	19.5%	17.4%	15.2%	13.7%	11.0%	9.4%	10.8%	14.6%	15.4%	16.0%	15.7%
1993	19.7%	19.6%	16.9%	15.3%	12.7%	10.9%	8.1%	7.4%	8.4%	12.2%	13.3%	13.9%	13.2%
1994	17.3%	17.2%	15.5%	14.3%	12.4%	10.8%	9.7%	8.2%	8.6%	12.8%	12.7%	14.2%	12.8%
1995	17.4%	17.1%	15.0%	12.9%	10.6%	9.8%	8.8%	7.9%	8.6%	12.7%	13.7%	14.9%	12.5%
1996	17.9%	18.3%	15.7%	14.6%	13.0%	11.5%	10.0%	8.6%	11.4%	15.0%	16.8%	17.1%	14.2%
1997	20.5%	20.0%	17.6%	15.3%	12.6%	11.6%	9.4%	8.1%	9.3%	12.7%	13.5%	13.4%	13.7%
1998	14.6%	14.4%	12.4%	10.5%	8.7%	8.8%	6.7%	5.6%	7.2%	9.7%	9.9%	10.7%	9.9%
1999	14.3%	16.3%	13.8%	12.0%	10.4%	9.8%	8.3%	7.5%	8.5%	10.4%	11.1%	11.1%	11.1%
2000	12.2%	12.2%	11.6%	10.1%	8.8%	7.7%	6.5%	6.6%	6.6%	7.7%	8.6%	9.3%	9.0%
2001	11.2%	11.4%	10.9%	9.8%	8.1%	7.7%	6.4%	6.8%	7.1%	8.2%	9.2%	10.2%	8.9%
2002	14.5%	14.6%	13.9%	12.1%	10.9%	9.5%	9.5%	9.1%	10.8%	13.3%	12.3%	14.7%	12.1%
2003	13.3%	13.9%	12.7%	11.6%	10.2%	10.5%	8.9%	9.0%	9.6%	10.7%	11.6%	12.2%	11.2%
2004	13.7%	13.7%	13.3%	11.5%	10.0%	9.9%	8.2%	8.2%	8.8%	9.8%	10.6%	11.2%	10.7%
2005	12.3%	12.7%	11.1%										

Table 1.43

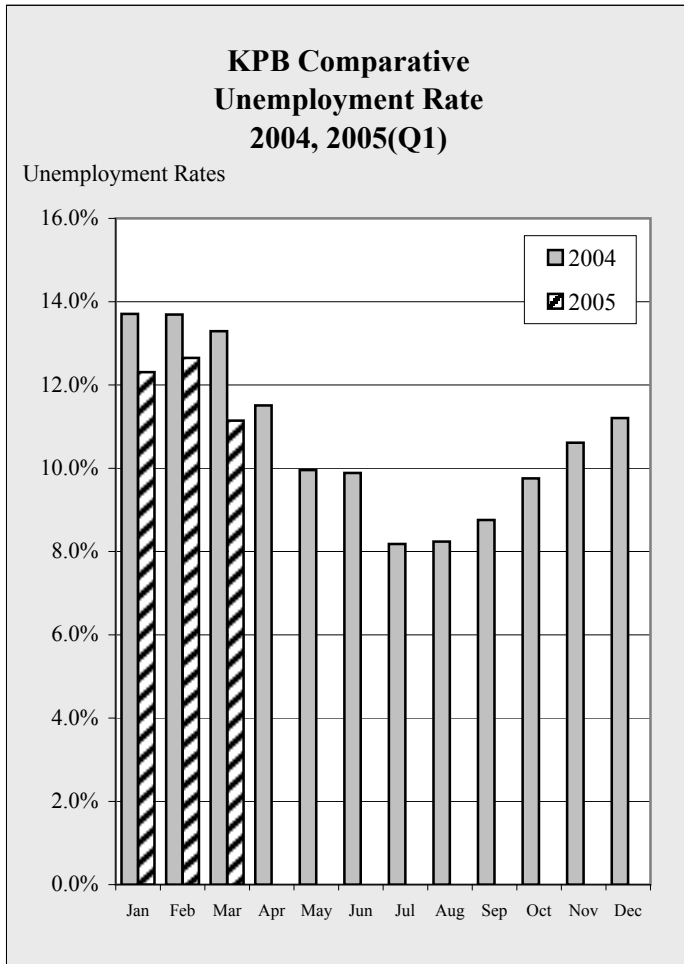

Chart 1.43

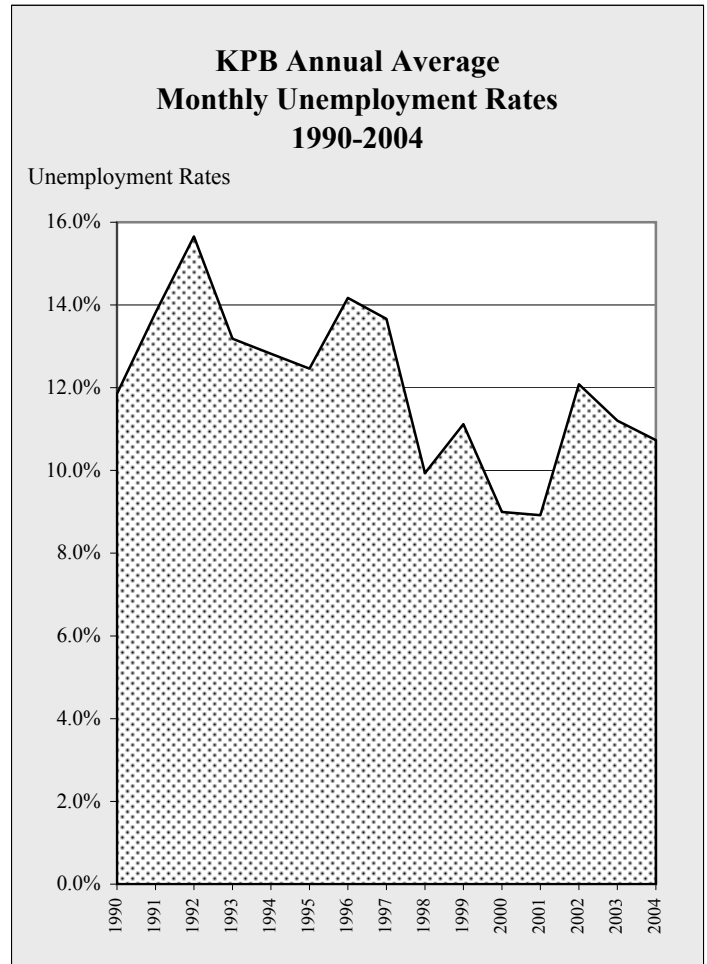

Chart 1.44

KPB Employment

KPB Employment by Month - 1990-2005

	Jan	Feb	Mar	Apr	May	Jun	Jul	Aug	Sep	Oct	Nov	Dec	Avg
1990	14,800	15,163	15,456	16,241	17,046	18,312	19,846	19,262	16,707	16,208	15,756	15,496	16,691
1991	15,420	15,652	15,969	16,834	17,423	18,471	20,346	19,563	17,778	16,145	15,521	15,051	17,014
1992	14,576	15,080	15,590	16,299	17,137	19,156	20,256	19,405	18,381	17,329	16,426	16,082	17,143
1993	14,882	15,693	16,486	17,091	17,863	20,352	22,136	21,336	18,902	18,043	17,151	16,607	18,045
1994	16,205	17,470	17,911	17,624	18,429	20,747	22,221	21,452	19,259	18,234	17,511	16,639	18,642
1995	17,014	17,556	17,828	17,855	18,862	20,502	22,203	21,635	19,695	28,715	17,634	16,949	19,704
1996	17,153	17,808	18,330	18,446	19,712	21,232	23,028	22,696	20,577	18,613	17,757	17,037	19,366
1997	17,286	17,934	18,049	18,624	19,298	21,394	23,090	22,430	20,374	18,619	17,814	17,286	19,350
1998	17,668	17,740	17,895	18,254	19,491	21,400	23,116	22,948	20,937	19,146	18,118	17,428	19,512
1999	17,508	17,726	18,035	18,529	19,237	20,820	22,120	21,639	20,359	18,898	17,950	17,530	19,196
2000	18,257	18,516	18,596	18,939	20,172	22,097	22,237	22,060	21,131	20,015	19,799	19,750	20,131
2001	18,481	18,406	18,545	18,821	20,022	21,686	22,589	21,496	20,484	19,597	19,342	19,274	19,895
2002	17,618	17,912	18,176	18,737	19,513	20,701	21,913	21,453	19,702	17,819	18,647	17,445	19,136
2003	19,042	18,783	19,135	19,461	20,577	21,626	22,317	21,629	20,041	19,370	19,141	18,924	20,004
2004	18,610	18,715	18,901	19,287	20,553	22,049	22,817	21,790	20,533	19,692	19,447	19,250	20,137
2005	19,166	19,078	19,531										

Table 1.44

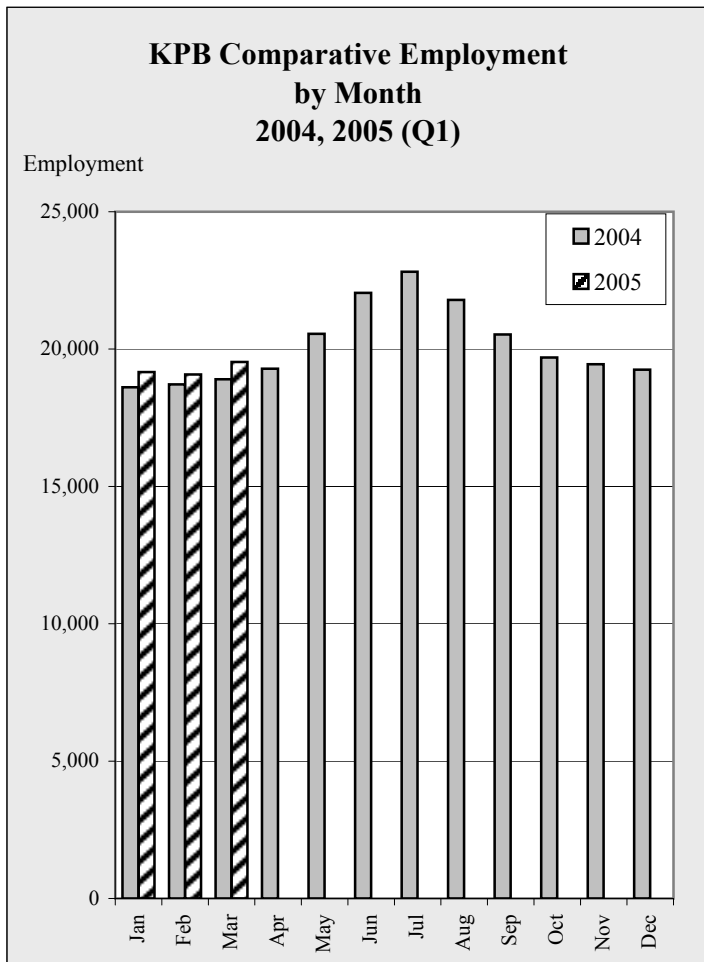

Chart 1.45

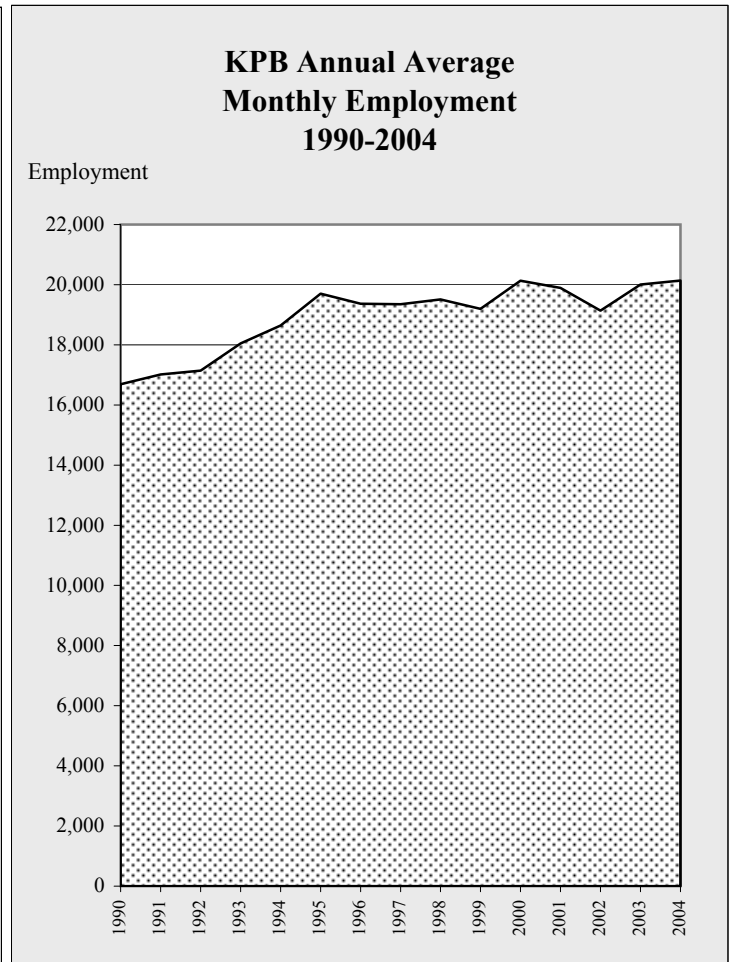

Chart 1.46

Census 2000

KPB Demographics

KPB population trends are determined through the decennial census conducted by the United States Census Bureau. A portion of Census 2000 data is presented in this section. Additional data is available through the U.S. Census Bureau or through the KPB CEDD office. Check out the U.S. Census Bureau website (<http://www.census.gov/>), which has two fantastic options, QuickFacts, and AmericanFactFinder.

Census data is collected for two types of area, incorporated cities and Census Designated Places (CDP). Incorporated cities within the KPB include Homer, Kachemak City, Kenai, Seldovia, Seward and Soldotna. To be classified as a CDP, there are no specific boundaries but rather geographic features such as rivers, roads, or ridges. Certain characteristics must be present, including:

- * A sense of community;
- * A population of 25 or more; and
- * It must have been recognized as possibly fitting the criteria four years prior to the census as planning began.

The Census Bureau considers an incorporated city with a population greater than 2,500 to be urban, of which there are four in the KPB: Homer, Kenai, Seward and Soldotna. As of Census 2000 Kenai is ranked 6th largest in Alaska, Homer ranks 14th, and Soldotna is the 15th largest Alaskan city.

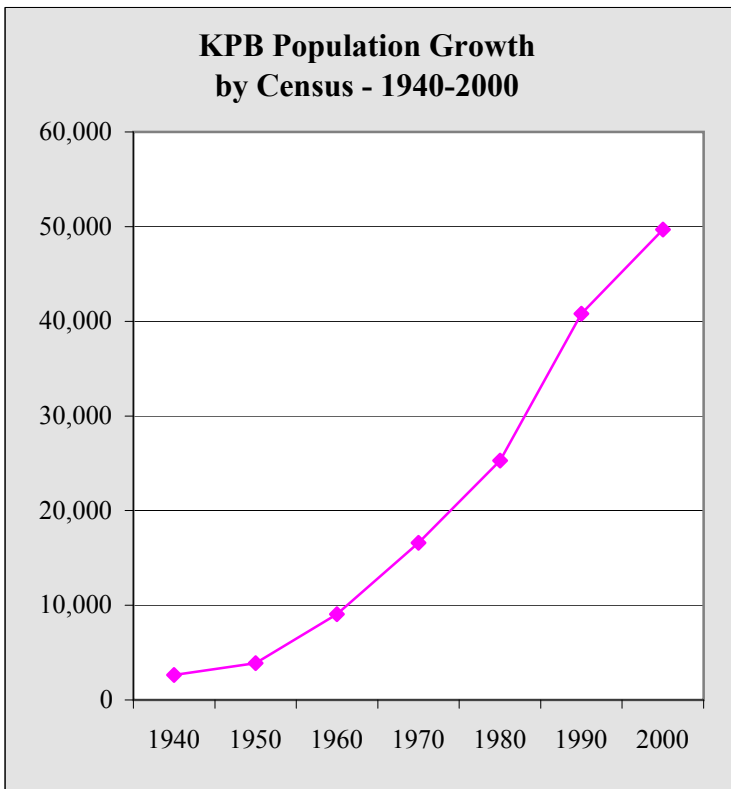

Chart 1.47

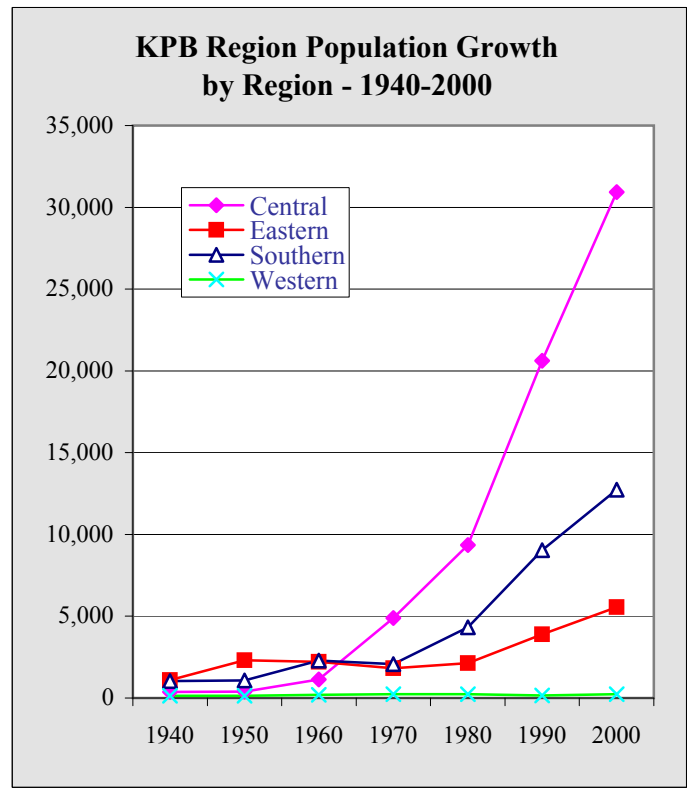

Chart 1.48

KPB Demographics

KPB CDP's Population Estimates - 2000 - 2004

KPB Community	2000 Census	June 1 Estimate (Subject to Annual Revision)				Annual Change
		2001	2002	2003	2004	
Anchor Point	1,845	1,809	1,784	1,812	1,792	-1.1%
Bear Creek	1,748	1,836	1,832	1,835	1,897	3.4%
Beluga	32	24	25	27	26	-3.7%
Clam Gulch	173	168	173	176	164	-6.8%
Cohoe	1,168	1,175	1,209	1,206	1,312	8.8%
Cooper Landing	369	391	372	358	351	-2.0%
Crown Point	75	89	88	78	89	14.1%
Diamond Ridge*	1,802	1,812	404	306	761	148.7%
Fox River	616	594	574	572	587	2.6%
Fritz Creek	1,603	1,662	1,735	1,744	1,732	-0.7%
Funny River	636	624	688	707	727	2.8%
Halibut Cove	35	29	28	27	26	-3.7%
Happy Valley	489	505	521	505	525	4.0%
Homer*	3,946	4,065	5,527	5,865	5,332	-9.1%
Hope	137	145	152	161	165	2.5%
Kachemak	431	426	433	478	475	-0.6%
Kalifornsky	5,846	6,011	6,153	6,249	6,617	5.9%
Kasilof	471	451	504	568	473	-16.7%
Kenai	6,942	6,870	7,071	7,123	6,809	-4.4%
Lowell Point	92	96	108	89	74	-16.9%
Miller Landing*	74	70				
Moose Pass	206	206	217	221	220	-0.5%
Nanwalek	177	184	219	214	203	-5.1%
Nikiski	4,327	4,362	4,360	4,356	4,279	-1.8%
Nikolaevsk	345	345	331	312	306	-1.9%
Ninilchik	772	758	760	774	783	1.2%
Port Graham	171	178	174	165	153	-7.3%
Primrose	93	98	92	86	90	4.7%
Ridgeway	1,932	1,961	1,963	2,022	2,047	1.2%
Salamatof	954	894	897	904	900	-0.4%
Seldovia**	430	435	450	431	426	-1.2%
Seldovia City**	286	285	288	279	263	-5.7%
Seldovia Village**	144	150	166	155	170	9.7%
Seward	2,830	2,759	2,754	2,745	2,540	-7.5%
Soldotna	3,759	3,791	3,856	3,992	3,767	-5.6%
Sterling	4,705	4,753	4,771	4,880	4,940	1.2%
Sunrise	18	16	14	15	19	26.7%
Tyonek	193	161	181	192	184	-4.2%
Remainder Kenai/Cook Inlet		229	188	190	181	-4.7%
Remainder Seward census sub area		23	13	13	8	-38.5%
Remainder of KPB	249					
Kenai Peninsula	49,691	50,005	50,621	51,398	50,980	-0.8%

Table 1.45

* - Homer annexation included all of Miller Landing CDP and part of Diamond Ridge CDP. Annexation was effective April 1, 2002.

** - Seldovia City plus Seldovia Village is not equal to the Seldovia CDP.

Note - All Estimates since 2000 have been revised by the State of Alaska Department of Labor and Workforce Development.

Source - <http://www.labor.state.ak.us/research/pop/estimates/04t4-3.xls>

KPB Demographics

KPB Census by Community/CDP - 1940-2000

KPB Community	Region	1940	1950	1960	1970	1980	1990	2000	
Anchor Point	S	20	65	171	102	226	866	1,845	
Bear Creek	E	0	0	0	0	0	580	1,748	
Beluga	W	New CDP - Census 2000							32
Clam Gulch	C	0	0	0	47	50	79	173	
Cohoe	C	0	0	122	0	0	508	1,168	
Cooper Landing	E	0	60	88	31	116	243	369	
Crown Point	E	0	0	0	0	0	62	75	
Diamond Ridge	S	New						1,802	
Fox River	S	0	0	0	0	0	382	616	
Fritz Creek	S	0	0	0	27	302	1,426	1,603	
Funny River	C	New CDP - Census 2000							636
Halibut Cove	S	0	0	25	44	47	78	35	
Happy Valley	S	0	0	0	0	0	309	489	
Homer	S	325	307	1,247	1,083	2,209	3,660	3,946	
Hope	E	71	63	44	51	103	161	137	
Jakalof Bay	S	Deleted - Census 2000					36	28	Deleted
Kachemak	S	0	0	0	76	403	365	431	
Kalifornsky	C	0	0	0	0	92	285	5,846	
Kasilof	C	62	62	89	71	201	383	471	
Kenai	C	303	321	778	3,533	4,324	6,327	6,942	
Lowell Point	E	New CDP - Census 2000							92
Miller Landing	S	New CDP - Census 2000							74
Moose Pass	E	84	70	136	53	76	81	206	
Nanwalek	S	48	75	78	58	124	158	177	
Nikiski	C		0	0	0	1,109	2,743	4,327	
Nikolaevsk	S	0	0	0	0	0	371	345	
Ninilchik	S	132	97	169	134	341	456	772	
Port Graham	S	93	92	139	107	161	166	171	
Primrose	E	0	0	0	0	0	63	93	
Ridgeway	C	0	0	0	0	0	2,018	1,932	
Salamatof	C	0	0	0	0	334	999	954	
Seldovia City	S	410	437	460	437	479	316	286	
Seward	E	949	2,114	1,891	1,587	1,843	2,699	2,830	
Soldotna	C	0	0	32	1,202	2,320	3,482	3,759	
Sterling	C	0	0	115	30	919	3,802	4,705	
Sunrise	C	New CDP - Census 2000							18
Tyonek	W	136	132	187	232	239	154	193	
Remainder of census area	E		946	3,282	7,681	16,116	7,409	249	
Kenai Peninsula Borough		2,633	4,831	9,053	16,586	25,282	40,802	49,691	

Table 1.46

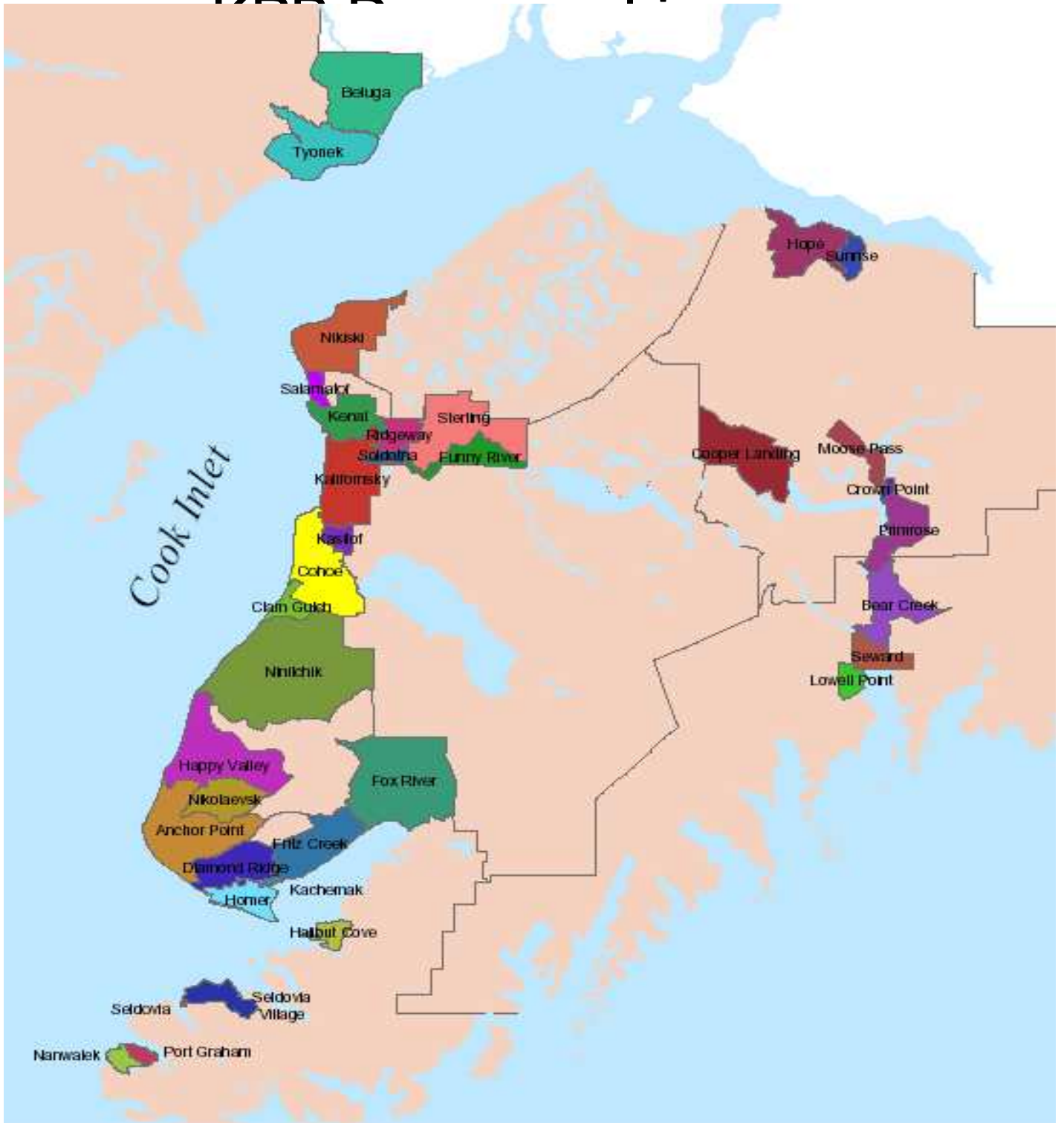

KENAI PENINSULA BOROUGH CENSUS DESIGNATED PLACES

Chart 1.49

KPB Demographics

	1990	2000	Percent Change	Percent of Total Population
Total Population	40,802	49,691	21.8%	
Under 5 years	3,862	3,288	-14.9%	6.6%
5 to 9 years	4,059	4,024	-0.9%	8.1%
10 to 14 years	3,516	4,698	33.6%	9.5%
15 to 19 years	2,970	4,140	39.4%	8.3%
20 to 24 years	2,081	2,132	2.5%	4.3%
25 to 34 years	7,348	5,648	-23.1%	11.4%
35 to 44 years	8,234	9,074	10.2%	18.3%
45 to 54 years	4,205	8,739	107.8%	17.6%
55 to 59 years	1,376	2,632	91.3%	5.3%
60 to 64 years	1,164	1,667	43.2%	3.4%
65 to 74 years	1,489	2,361	58.6%	4.8%
75 to 84 years	419	1,077	157.0%	2.2%
85 years and over	79	211	167.1%	0.4%

Table 1.47

KPB's median age increased from 31.1 years during the 1990 census to 36.3 as of Census 2000. Alaska's median age is 32.4 years while the United States median age is 35.3 years.

KPB's 2003 population, estimated by the AK DOL&WD is estimated at 51,220, a 0.1% increase over 2002. Estimates are based primarily on births, deaths and Permanent Fund Dividend applications.

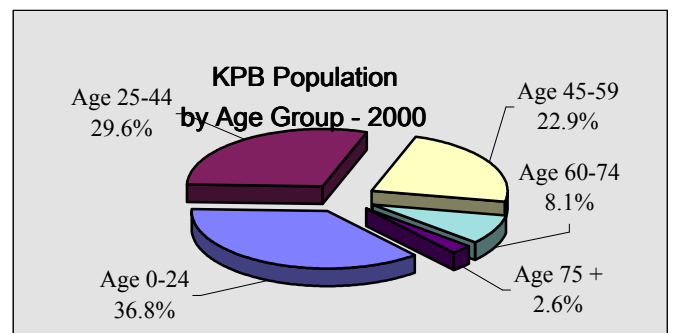

Chart 1.50

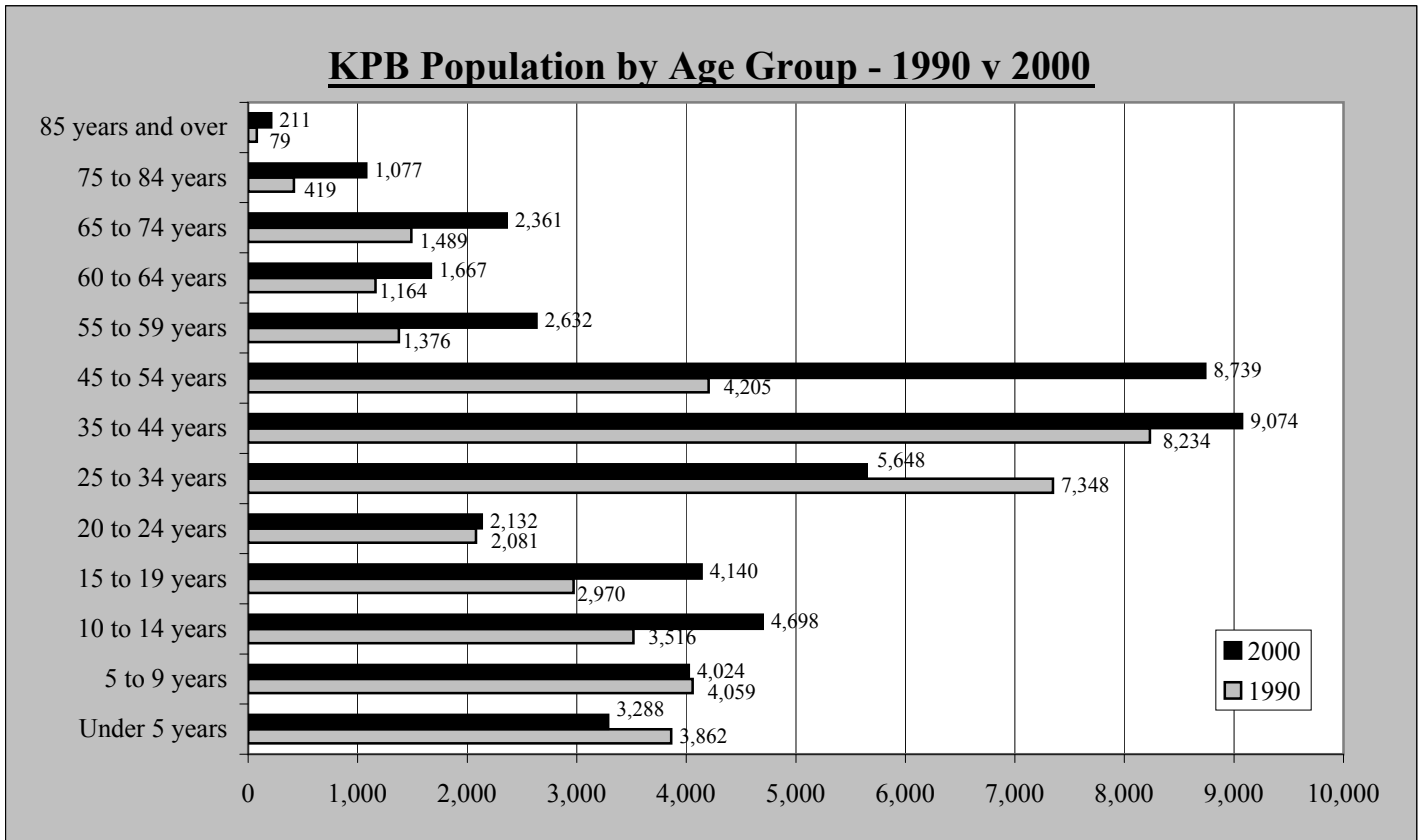

Chart 1.51

KPB Select Data - 1990 v 2000 Demographics

Population					Housing				
	1990	2000	Percent Change	Percent of Total		1990	2000	Percent Change	Percent of Total
Total Population	40,802	49,691	21.8%	100.0%	Total Households	14,250	18,438	29.4%	100.0%
Male	21,606	25,853	19.7%	52.0%	Family Households	10,216	12,716	24.5%	69.0%
Female	19,196	23,838	24.2%	48.0%	With Children Under 18		7,003	NA	38.0%
Under 5 years	3,795	3,288	-13.4%	6.6%	Married Couple Family	8,456	10,218	20.8%	55.4%
5 to 9 years	4,104	4,024	-1.9%	8.1%	With Own Children Under 18		5,133	NA	27.8%
10 to 14 years	3,505	4,698	34.0%	9.5%	Female Householder, no husband present		1,654	NA	9.0%
15 to 19 years	2,939	4,140	40.9%	8.3%	With Own Children Under 18		1,276	NA	6.9%
20 to 24 years	2,086	2,132	2.2%	4.3%	Average Household Size	2.79	2.62	-6.1%	0.0%
25 to 34 years	7,281	5,648	-22.4%	11.4%	Average Family Size		3.15	NA	0.0%
35 to 44 years	8,229	9,074	10.3%	18.3%	Total Housing Units	19,364	24,871	NA	100.0%
45 to 54 years	4,280	8,739	104.2%	17.6%	Occupied Housing Units	14,250	18,438	29.4%	74.1%
55 to 59 years	1,387	2,632	89.8%	5.3%	Vacant Housing Units	5,114	6,433	25.8%	25.9%
60 to 64 years	1,181	1,667	41.2%	3.4%	Seasonal, Recreational, Occasional Use	2,819	4,560	61.8%	18.3%
65 to 74 years	1,503	2,361	57.1%	4.8%	Owner Vacancy Rate	4.1%	2.9%	NA	NA
75 to 84 years	431	1,077	149.9%	2.2%	Rental Vacancy Rate	13.9%	14.4%	NA	NA
85 years and over	81	211	160.5%	0.4%	Owner Occupied Units	9,677	13,585	40.4%	54.6%
Median Age	31.1	36.3	16.7%	NA	Renter Occupied Units	4,573	4,853	6.1%	19.5%
18 Years and Over	13,396	34,832	160.0%	70.1%	Marital Status (over 15)		37,696	NA	100.0%
Male		18,239	NA	NA	Never married		8,829	NA	23.4%
Female		16,593	NA	NA	Married except separated		22,022	NA	58.4%
65 Years and Over	2,015	3,649	81.1%	7.3%	Separated		698	NA	1.9%
Male		1,765	NA	NA	Widowed		1,330	NA	3.5%
Female		1,884	NA	NA	Divorced		4,817	NA	12.8%
Place of Birth					Disabled, Noninstitutionalized				
Native Born	39,726	48,335	21.7%	97.3%	Population 5 to 20		13,244	NA	100.0%
Born in Alaska		17,440	NA	35.1%	With a Disability		842	NA	6.4%
Born in other state		30,444	NA	61.3%	Population 21 to 64		28,547	NA	100.0%
Foreign Born	1,076	1,356	26.0%	2.7%	With a Disability		4,843	NA	17.0%
Naturalized Citizen		872	NA	1.8%	Percent Employed		45.4%	NA	45.4%
Not a Citizen		484	NA	1.0%	Without a Disability		23,704	NA	83.0%
Veteran Status					Percent Employed		69.9%	NA	69.9%
Civilian veterans	5,335	5,941	11.4%	17.1%	Income in 1999 - Families				
Educational Attainment							Total		12,736
Population 25 years and over				31,388	Less than \$10,000	604	602	-0.3%	4.7%
Less than 9th grade	934	985	5.5%	3.1%	\$10,000 - \$14,999	548	512	-6.6%	4.0%
9th-12th, no diploma	2,185	2,620	19.9%	8.3%	\$15,000 - \$24,999	1,177	1,248	6.0%	9.8%
High School Diploma	8,560	9,990	16.7%	31.8%	\$25,000 - \$34,999	1,151	1,396	21.3%	11.0%
College, no degree	6,581	9,492	44.2%	30.2%	\$35,000 - \$49,999	1,895	1,970	4.0%	15.5%
Associate Degree	1,789	1,939	8.4%	6.2%	\$50,000 - \$74,999	2,688	3,148	17.1%	24.7%
Bachelor's Degree	3,165	4,254	34.4%	13.6%	\$75,000 - \$99,999	1,361	1,855	36.3%	14.6%
Graduate, Profess Degree	1,209	2,108	74.4%	6.7%	\$100,000 - \$149,999	687	1,561	127.2%	12.3%
Percent HS Grad	87.2%	88.5%	1.5%	NA	\$150,000 - \$199,999	279	245	-12.2%	1.9%
Percent Bachelor's +	17.9%	20.3%	13.4%	NA	\$200,000 or more	NA	199	NA	1.6%
					Median Income - \$	48,339	54,106	11.9%	NA

Table 1.48

Homer Sales

Homer 1st Quarter Gross Sales by Industry - 1999-2005 - in \$

	1999	2000	2001	2002	2003	2004	2005	Annual Change
AFF	94,065	174,500	160,466	134,712	249,333	229,352	264,446	15.3%
Min	195	0	9,137	1,363	0	256	0	NA
Const	6,011,769	7,295,167	8,123,440	8,430,924	9,795,523	4,325,965	4,253,028	-1.7%
Manu	3,510,592	1,753,833	1,325,393	1,253,834	1,317,636	1,116,143	725,931	-35.0%
TCPU	8,313,407	7,762,978	8,393,207	9,784,288	9,460,657	9,977,448	10,868,207	8.9%
Whole	4,137,168	3,177,603	3,500,654	3,358,010	4,044,595	4,122,172	3,928,233	-4.7%
Retail	11,284,262	12,205,397	12,926,124	13,767,872	17,108,705	18,227,417	19,595,441	7.5%
FIRE	1,957,019	1,447,561	1,405,203	1,527,725	1,989,925	2,247,358	1,996,686	-11.2%
Service	4,245,171	4,638,128	5,001,354	6,006,218	7,261,902	7,895,860	8,120,660	2.8%
Govt	0	0	0	0	0	394	0	-100.0%
Total	39,553,648	38,455,167	40,844,978	44,264,946	51,228,276	48,142,365	49,752,632	3.3%
Annual Change		-2.8%	6.2%	8.4%	15.7%	-6.0%	3.3%	

Table 2.1

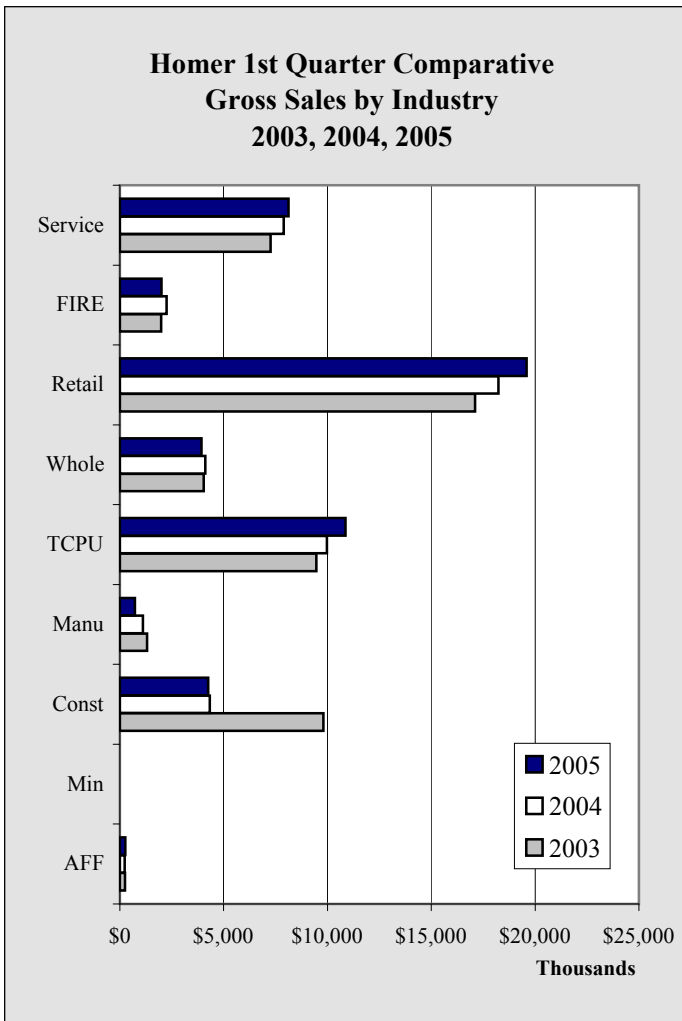

Chart 2.1

Homer's annexation became effective 4/1/2002

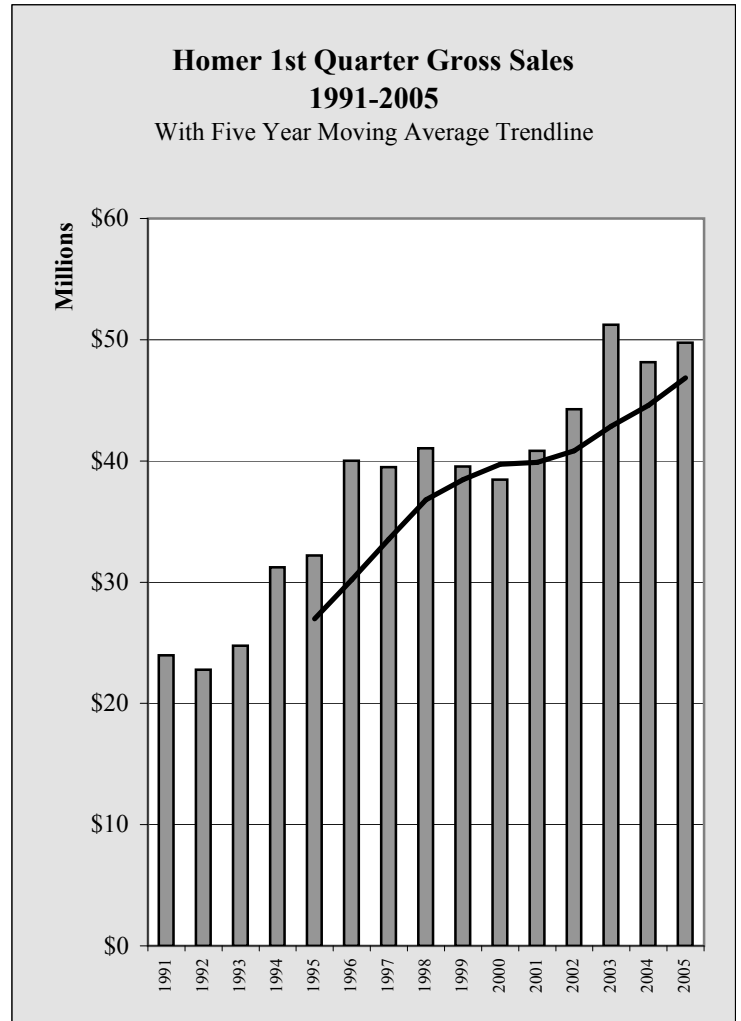

Chart 2.2

Homer Sales

Homer 1st Quarter Taxable Sales by Industry - 1999-2005 - in \$								
	1999	2000	2001	2002	2003	2004	2005	Annual Change
AFF	79,865	108,581	108,289	117,273	135,734	157,957	181,451	14.9%
Min	195	0	1,640	710	0	0	0	NA
Const	182,033	214,922	178,792	237,634	243,346	276,885	219,709	-20.6%
Manu	345,033	352,233	325,875	263,252	277,526	305,351	212,592	-30.4%
TCPU	2,300,797	2,182,015	2,129,650	2,225,122	2,890,615	2,806,506	2,836,081	1.1%
Whole	1,510,910	1,649,698	1,691,835	1,662,455	2,010,808	2,234,379	1,690,457	-24.3%
Retail	8,815,674	9,187,838	9,549,519	10,100,688	11,998,705	12,978,758	13,291,621	2.4%
FIRE	661,240	675,571	692,034	768,568	900,146	890,703	826,738	-7.2%
Service	2,742,720	2,957,002	3,087,570	3,321,402	3,993,060	4,175,189	4,185,920	0.3%
Govt	0	0	0	0	0	394	0	-100.0%
Total	16,638,467	17,327,860	17,765,204	18,697,104	22,449,940	23,826,122	23,444,569	-1.6%
Annual Change		4.1%	2.5%	5.2%	20.1%	6.1%	-1.6%	

Table 2.2

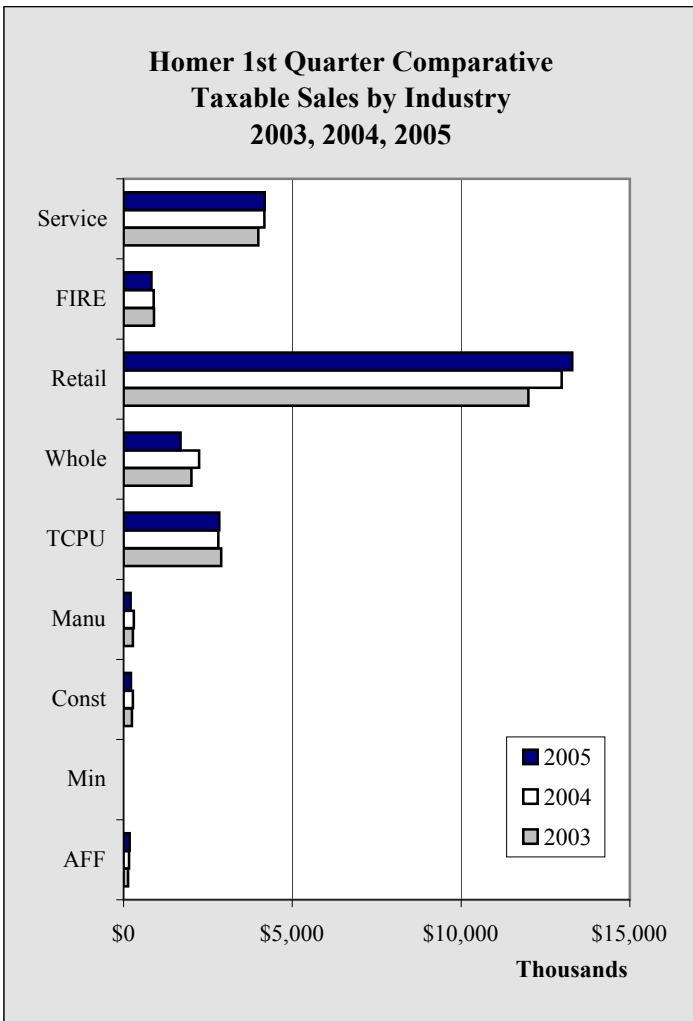

Chart 2.3
Homer's annexation became effective 4/1/2002

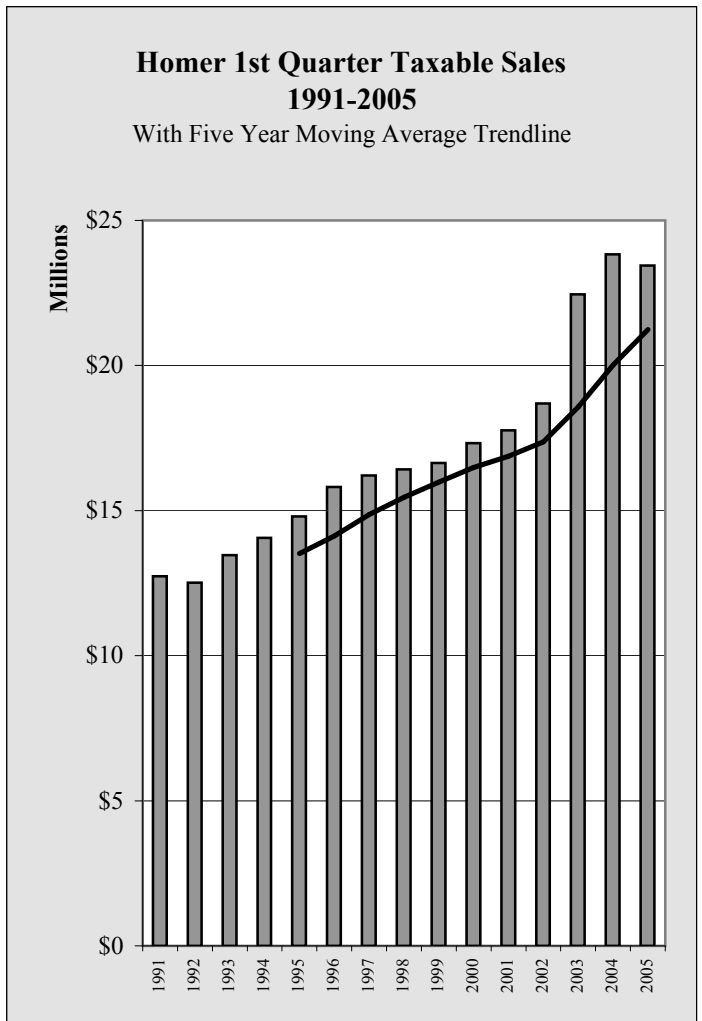

Chart 2.4

Homer Annual Gross Sales by Industry - 1998-2004 - in \$

	1998	1999	2000	2001	2002	2003	2004	Annual Change
AFF	1,231,758	1,132,289	1,763,891	931,926	1,013,352	1,592,413	1,520,013	-4.5%
Min	130	13,595	24,864	15,819	8,582	1,283	151,171	11682.6%
Const	37,787,332	27,642,104	42,378,954	40,149,696	45,829,436	41,984,440	32,449,476	-22.7%
Manu	19,649,701	16,450,883	6,761,789	6,482,895	6,590,594	6,755,907	5,657,729	-16.3%
TCPU	34,491,856	33,675,536	34,493,682	40,495,596	42,137,752	39,996,686	40,511,899	1.3%
Whole	14,672,913	17,513,809	16,999,389	18,602,483	19,915,750	22,075,685	26,528,880	20.2%
Retail	64,712,270	66,221,369	71,465,479	75,795,576	88,239,711	97,820,663	105,672,450	8.0%
FIRE	8,574,588	7,448,936	6,682,678	7,544,432	8,453,334	9,936,484	12,077,132	21.5%
Service	31,322,069	33,743,954	35,410,998	39,685,084	51,007,289	53,867,042	59,092,037	9.7%
Govt	0	0	0	0	0	263	394	49.8%
Total	212,442,617	203,842,475	215,981,724	229,703,507	263,195,800	274,030,603	283,660,787	3.5%
Annual Change		-4.0%	6.0%	6.4%	14.6%	4.1%	3.5%	

Table 2.3

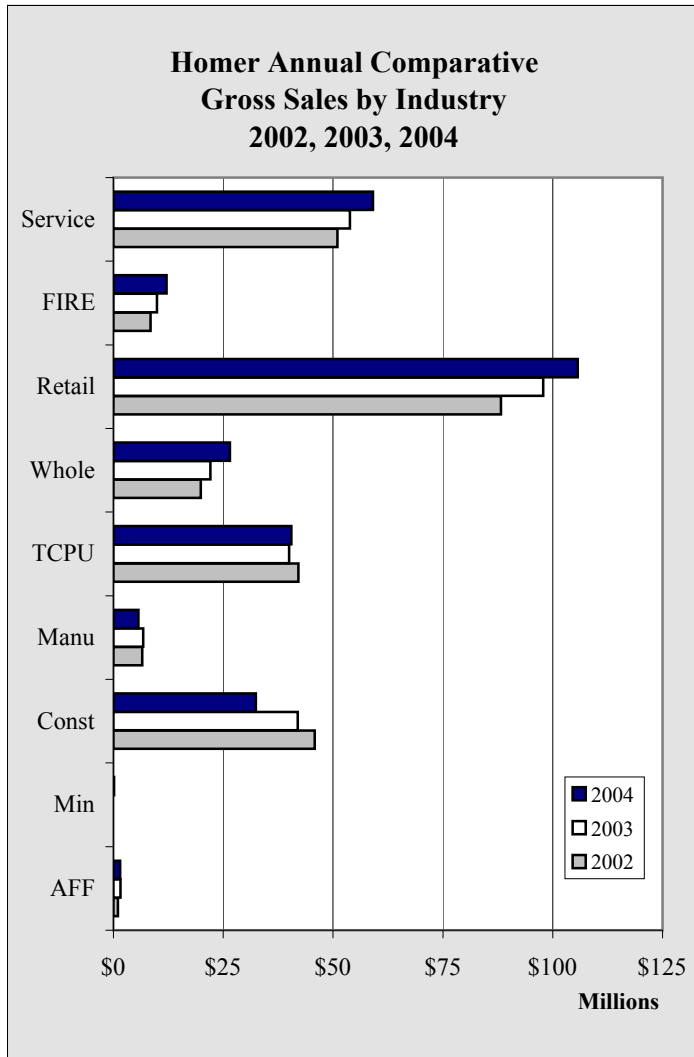

Chart 2.5

Homer's annexation became effective 4/1/2002

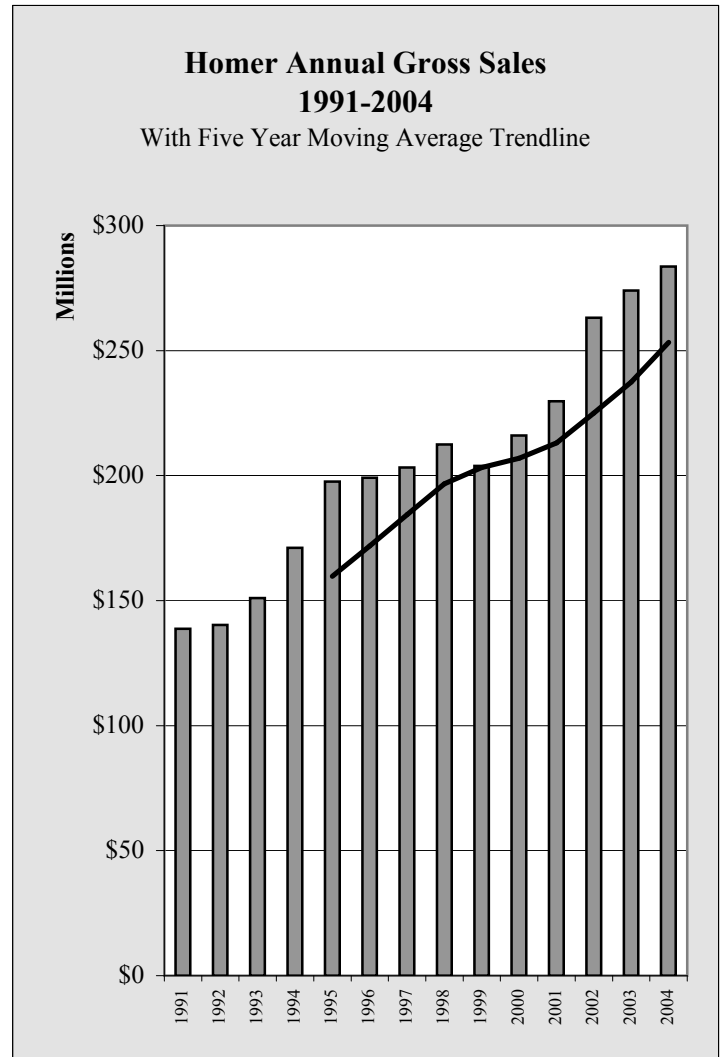

Chart 2.6

Homer Annual Taxable Sales by Industry - 1998-2004 - in \$								
	1998	1999	2000	2001	2002	2003	2004	Annual Change
AFF	626,058	461,892	519,595	577,360	641,294	773,421	912,356	18.0%
Min	130	195	1,104	5,993	2,665	347	104	-70.0%
Const	820,655	891,101	891,188	940,211	1,125,715	1,208,909	1,182,169	-2.2%
Manu	2,087,103	2,084,079	2,045,894	1,769,534	1,822,345	1,848,166	1,857,314	0.5%
TCPU	9,578,082	10,137,988	10,110,454	10,200,922	11,698,087	12,717,059	12,827,427	0.9%
Whole	7,485,103	8,034,552	8,633,107	8,953,325	8,876,648	10,611,085	11,429,493	7.7%
Retail	48,994,370	50,357,048	53,206,860	56,027,806	63,864,887	69,823,667	74,187,604	6.2%
FIRE	2,814,367	2,949,461	3,147,793	3,460,712	3,890,685	4,074,657	4,984,716	22.3%
Service	22,035,474	23,232,422	24,634,121	25,375,676	29,345,792	30,574,151	32,675,985	6.9%
Govt	0	0	0	0	0	263	394	49.8%
Total	94,441,342	98,148,738	103,190,116	107,311,539	121,268,118	131,631,462	140,057,168	6.4%
Annual Change		3.9%	5.1%	4.0%	13.0%	8.5%	6.4%	

Table 2.4

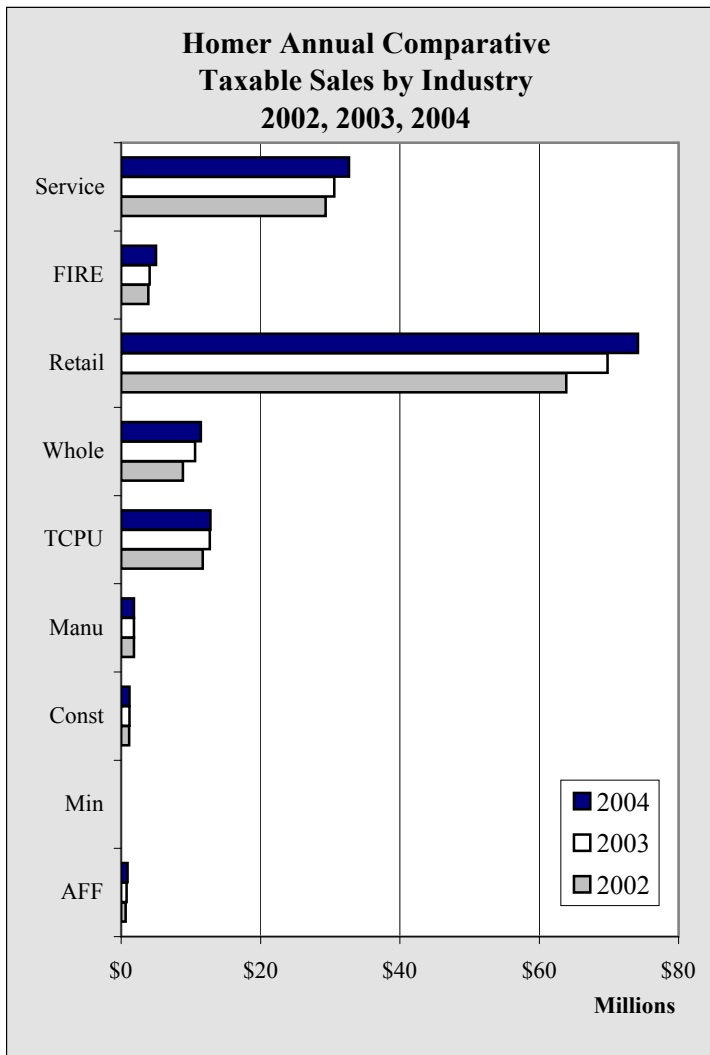

Chart 2.7

Homer's annexation became effective 4/1/2002

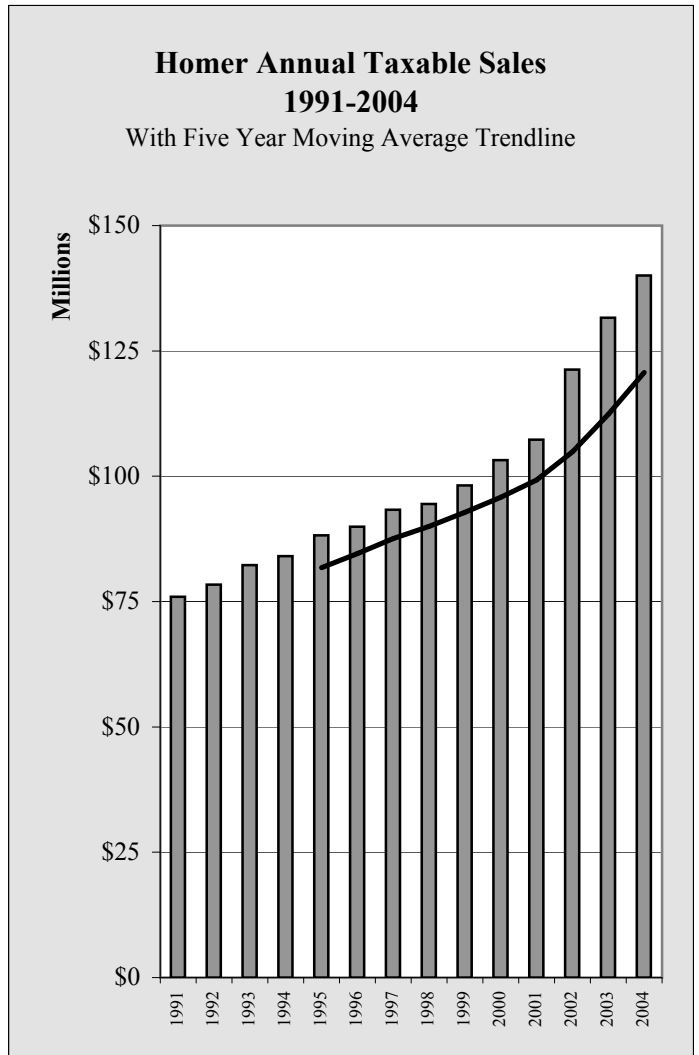

Chart 2.8

Homer Gross Sales by Industry by Quarter - 2001-2005 - in \$					
	1st Quarter	2nd Quarter	3rd Quarter	4th Quarter	Total
2001					
AFF	160,466	221,357	369,625	180,478	931,926
Min	9,137	1,844	4,209	629	15,819
Const	8,123,440	6,727,125	13,713,481	11,585,650	40,149,696
Manu	1,325,393	1,455,193	1,967,400	1,734,909	6,482,895
TCPU	8,393,207	8,926,617	12,698,696	10,477,076	40,495,596
Whole	3,500,654	5,204,028	6,252,096	3,645,705	18,602,483
Retail	12,926,124	20,975,149	24,152,918	17,741,385	75,795,576
FIRE	1,405,203	1,982,111	2,278,077	1,879,041	7,544,432
Service	5,001,354	11,364,051	16,017,454	7,302,225	39,685,084
Govt	0	0	0	0	0
Total	40,844,978	56,857,475	77,453,956	54,547,098	229,703,507
2002					
AFF	134,712	250,389	358,911	269,340	1,013,352
Min	1,363	3,836	3,383	0	8,582
Const	8,430,924	7,437,731	15,972,357	13,988,424	45,829,436
Manu	1,253,834	1,790,421	2,153,455	1,392,884	6,590,594
TCPU	9,784,288	10,982,097	11,525,181	9,846,186	42,137,752
Whole	3,358,010	5,360,132	6,595,619	4,601,989	19,915,750
Retail	13,767,872	24,997,009	28,967,558	20,507,272	88,239,711
FIRE	1,527,725	2,046,589	2,696,231	2,182,789	8,453,334
Service	6,006,218	15,803,541	21,417,906	7,779,624	51,007,289
Govt	0	0	0	0	0
Total	44,264,946	68,671,745	89,690,601	60,568,508	263,195,800
2003					
AFF	249,333	420,146	485,712	437,222	1,592,413
Min	0	0	448	835	1,283
Const	9,795,523	11,071,038	11,629,038	9,488,841	41,984,440
Manu	1,317,636	1,899,935	2,019,280	1,519,056	6,755,907
TCPU	9,460,657	9,778,534	11,335,988	9,421,507	39,996,686
Whole	4,044,595	6,092,813	6,629,440	5,308,837	22,075,685
Retail	17,108,705	27,557,784	31,205,896	21,948,278	97,820,663
FIRE	1,989,925	2,547,744	2,825,493	2,573,322	9,936,484
Service	7,261,902	15,919,950	21,057,005	9,628,185	53,867,042
Govt	0	0	0	263	263
Total	51,228,276	75,287,944	87,188,300	60,326,346	274,030,866
2004					
AFF	229,352	430,095	512,372	348,194	1,520,013
Min	256	104	695	150,116	151,171
Const	4,325,965	5,685,550	9,736,168	12,701,793	32,449,476
Manu	1,116,143	1,807,647	1,752,124	981,815	5,657,729
TCPU	9,977,448	5,034,111	13,967,425	11,532,915	40,511,899
Whole	4,122,172	6,421,737	7,325,763	8,659,208	26,528,880
Retail	18,227,417	30,021,416	34,477,697	22,945,920	105,672,450
FIRE	2,247,358	2,619,310	3,341,741	3,868,723	12,077,132
Service	7,895,860	16,947,718	22,804,715	11,443,744	59,092,037
Govt	394	0	0	0	394
Total	48,142,365	68,967,688	93,918,700	72,632,428	283,661,181
2005					
AFF	264,446				264,446
Min	0				0
Const	4,253,028				4,253,028
Manu	725,931				725,931
TCPU	10,868,207				10,868,207
Whole	3,928,233				3,928,233
Retail	19,595,441				19,595,441
FIRE	1,996,686				1,996,686
Service	8,120,660				8,120,660
Govt	0				0
Total	49,752,632				49,752,632
Year to Date					

Table 2.5

Homer Taxable Sales by Industry by Quarter - 2001-2005 - in \$					
	1st Quarter	2nd Quarter	3rd Quarter	4th Quarter	Total
2001					
AFF	108,289	146,035	177,823	145,213	577,360
Min	1,640	1,549	2,175	629	5,993
Const	178,792	217,384	280,862	263,173	940,211
Manu	325,875	528,377	525,720	389,562	1,769,534
TCPU	2,129,650	2,581,062	3,245,406	2,244,804	10,200,922
Whole	1,691,835	2,538,512	2,883,405	1,839,573	8,953,325
Retail	9,549,519	15,861,254	18,278,875	12,338,158	56,027,806
FIRE	692,034	923,819	1,006,507	838,352	3,460,712
Service	3,087,570	7,393,485	11,173,929	3,720,692	25,375,676
Govt	0	0	0	0	0
Total	17,765,204	30,191,477	37,574,702	21,780,156	107,311,539
2002					
AFF	117,273	166,982	195,905	161,134	641,294
Min	710	1,955	0	0	2,665
Const	237,634	266,994	324,412	296,675	1,125,715
Manu	263,252	557,095	597,126	404,872	1,822,345
TCPU	2,225,122	2,873,043	3,752,729	2,847,193	11,698,087
Whole	1,662,455	2,518,226	2,928,198	1,767,769	8,876,648
Retail	10,100,688	18,247,283	21,308,629	14,208,287	63,864,887
FIRE	768,568	1,005,737	1,165,651	950,729	3,890,685
Service	3,321,402	8,630,174	12,978,461	4,415,755	29,345,792
Govt	0	0	0	0	0
Total	18,697,104	34,267,489	43,251,111	25,052,414	121,268,118
2003					
AFF	135,734	212,539	250,473	174,675	773,421
Min	0	0	0	347	347
Const	243,346	312,650	335,295	317,618	1,208,909
Manu	277,526	532,466	618,081	420,093	1,848,166
TCPU	2,890,615	3,212,975	3,752,532	2,860,937	12,717,059
Whole	2,010,808	2,966,252	3,370,701	2,263,324	10,611,085
Retail	11,998,705	19,762,887	22,642,061	15,420,014	69,823,667
FIRE	900,146	1,062,609	1,146,791	965,111	4,074,657
Service	3,993,060	8,965,906	12,965,331	4,649,854	30,574,151
Govt	0	0	0	263	263
Total	22,449,940	37,028,284	45,081,265	27,072,236	131,631,725
2004					
AFF	157,957	247,630	305,982	200,787	912,356
Min	0	104	0	0	104
Const	276,885	319,319	300,979	284,986	1,182,169
Manu	305,351	608,034	632,048	311,881	1,857,314
TCPU	2,806,506	3,248,197	3,909,932	2,862,792	12,827,427
Whole	2,234,379	3,320,836	3,998,096	1,876,182	11,429,493
Retail	12,978,758	21,267,878	24,233,534	15,707,434	74,187,604
FIRE	890,703	1,153,472	1,453,305	1,487,236	4,984,716
Service	4,175,189	9,501,560	14,224,768	4,774,468	32,675,985
Govt	394	0	0	0	394
Total	23,826,122	39,667,030	49,058,644	27,505,766	140,057,562
2005					
					Year to Date
AFF	181,451				181,451
Min	0				0
Const	219,709				219,709
Manu	212,592				212,592
TCPU	2,836,081				2,836,081
Whole	1,690,457				1,690,457
Retail	13,291,621				13,291,621
FIRE	826,738				826,738
Service	4,185,920				4,185,920
Govt	0				0
Total	23,444,569				23,444,569

Table 2.6

Homer 1st Quarter Permit Values by Type - 1999-2005 - in \$

	1999	2000	2001	2002	2003	2004	2005	Annual Change
Residential New	1,673,000	392,600	300,000	891,760	979,800	2,597,500	1,694,400	-34.8%
Residential Alter/Add	0	5,500	60,000	8,960	232,540	201,520	1,500	-99.3%
Commercial New	270,000	85,000	285,000	0	0	915,000	108,000	-88.2%
Commercial Alter/Add	0	1,315,000	45,000	28,000	122,000	0	1,302,000	NA
TOTAL	1,943,000	1,798,100	690,000	928,720	1,334,340	3,714,020	3,105,900	-16.4%
Annual Change		-7.5%	-61.6%	34.6%	43.7%	178.3%	-16.4%	

Table 2.7

Homer 1st Quarter Permit Values by Type - 1986-2005

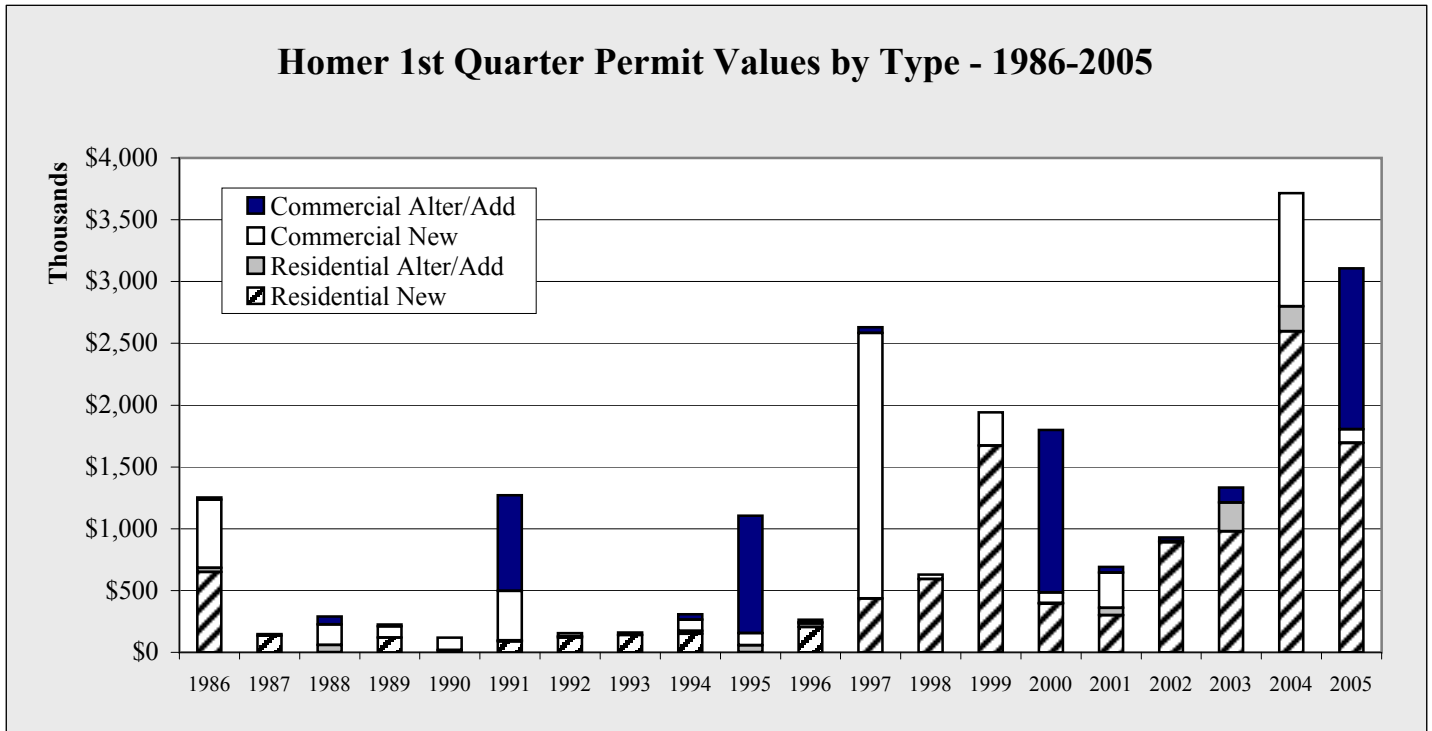

Chart 2.9

Homer 1st Quarter Permit Values Percent by Type - 2005

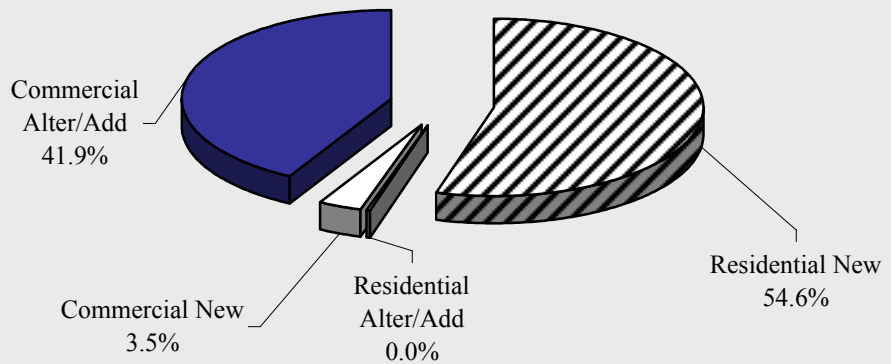

Chart 2.10

Homer 1st Quarter Permit Volume by Type - 1999-2005

	1999	2000	2001	2002	2003	2004	2005	Annual Change
Residential New	3	4	3	8	6	11	10	-9.1%
Residential Alter/Add	0	1	1	1	8	2	1	-50.0%
Commercial New	2	1	2	0	0	2	2	0.0%
Commercial Alter/Add	0	3	1	1	4	1	5	400.0%
TOTAL	5	9	7	10	18	16	18	12.5%
Annual Change		80.0%	-22.2%	42.9%	80.0%	-11.1%	12.5%	

Table 2.8

Homer 1st Quarter Permit Volume by Type - 1986-2005

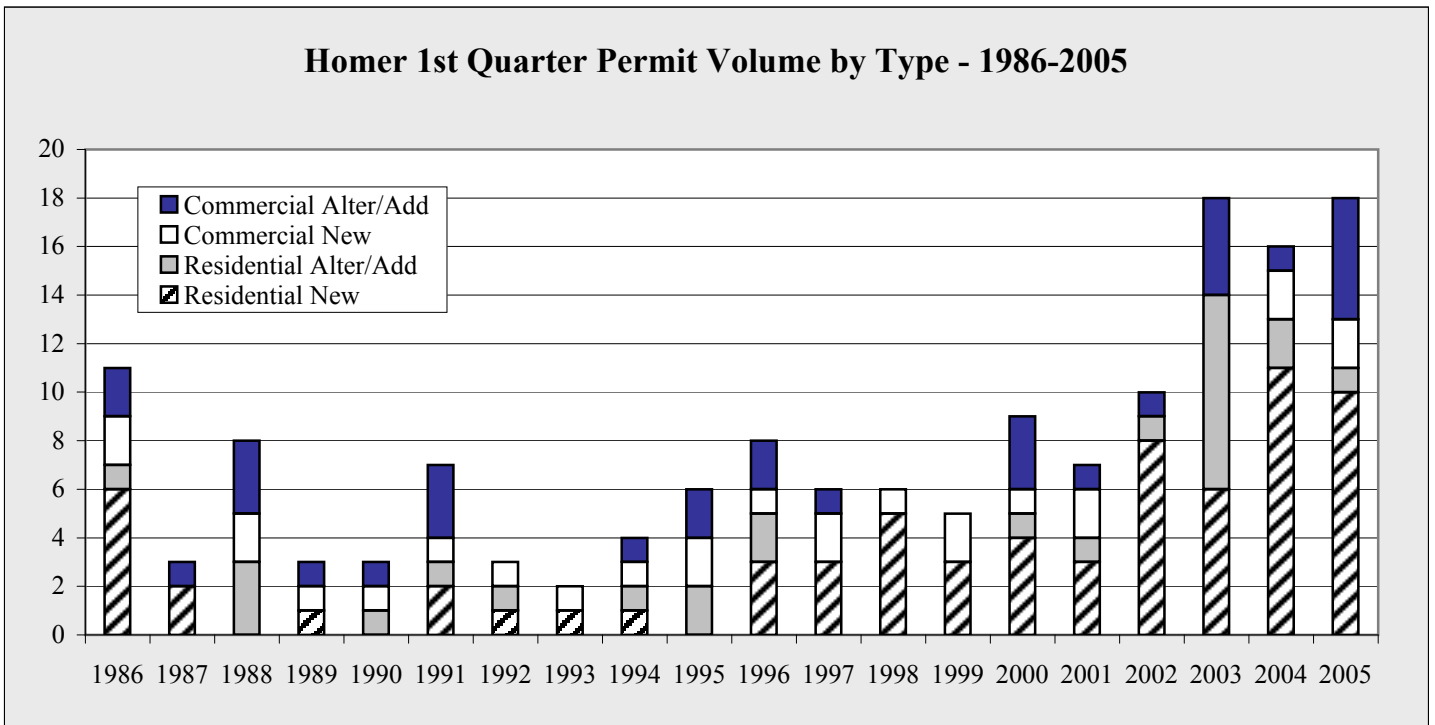

Chart 2.11

Homer 1st Quarter Permit Volume Percent by Type - 2005

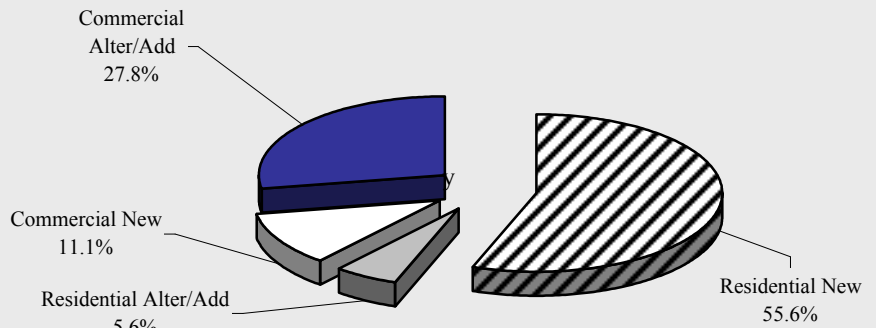

Chart 2.12

Homer Annual Permit Values by Type - 1998-2004 - in \$

	1998	1999	2000	2001	2002	2003	2004	Annual Change
Residential New	2,850,750	3,646,000	2,611,040	4,047,780	4,226,720	8,120,455	6,695,500	-17.5%
Residential Alter/Add	539,600	367,000	230,060	609,160	536,620	806,600	1,695,550	110.2%
Commercial New	2,528,025	6,906,000	1,663,480	2,410,800	4,990,740	5,764,520	14,400,518	149.8%
Commercial Alter/Add	281,500	21,000	2,624,392	12,732,950	294,699	635,240	1,279,063	101.4%
TOTAL	6,199,875	10,940,000	7,128,972	19,800,690	10,048,779	15,326,815	24,070,631	57.0%
Annual Change		76.5%	-34.8%	177.7%	-49.3%	52.5%	57.0%	

Table 2.9

Homer Annual Permit Values by Type - 1986-2004

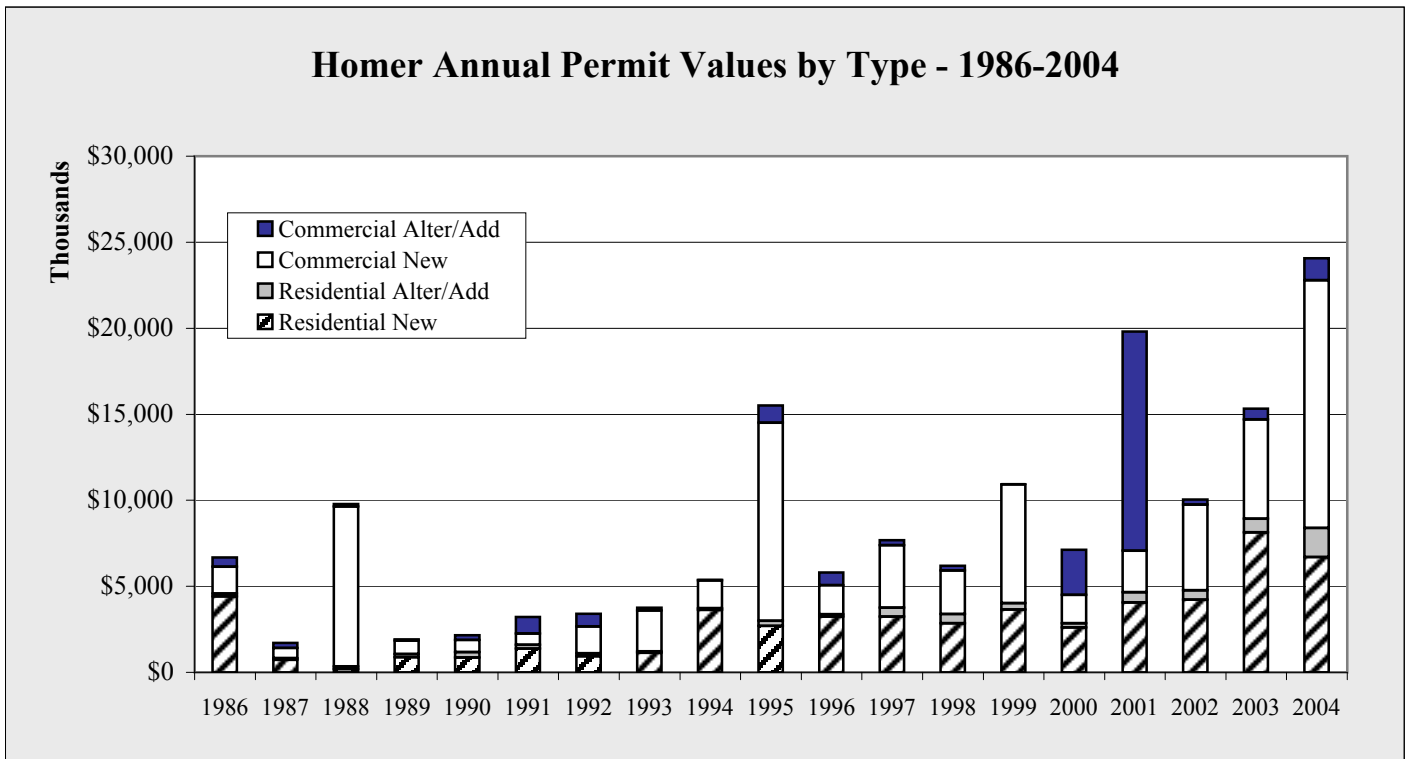

Chart 2.13

**Homer Annual Permit Values
Percent by Type - 2004**

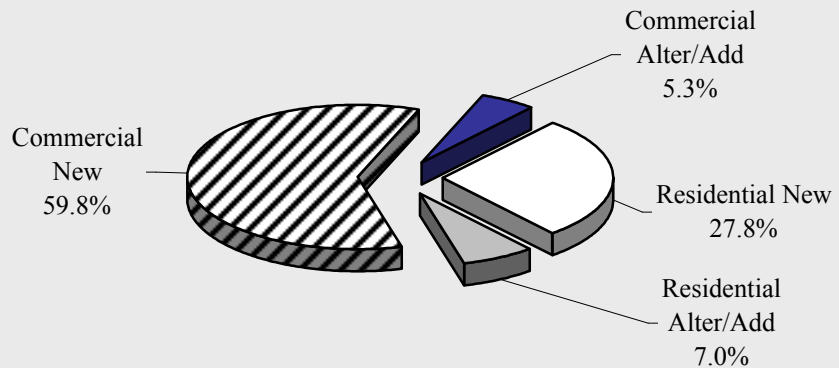

Chart 2.14

Homer Annual Permit Volume by Type - 1998-2004

	1998	1999	2000	2001	2002	2003	2004	Annual Change
Residential New	23	21	23	30	32	47	41	-12.8%
Residential Alter/Add	11	17	8	19	20	19	37	94.7%
Commercial New	9	12	8	8	8	11	22	100.0%
Commercial Alter/Add	5	2	19	15	7	9	8	-11.1%
TOTAL	48	52	58	72	67	86	108	25.6%
Annual Change		8.3%	11.5%	24.1%	-6.9%	28.4%	25.6%	

Table 2.10

Homer Annual Permit Volume by Type - 1986-2004

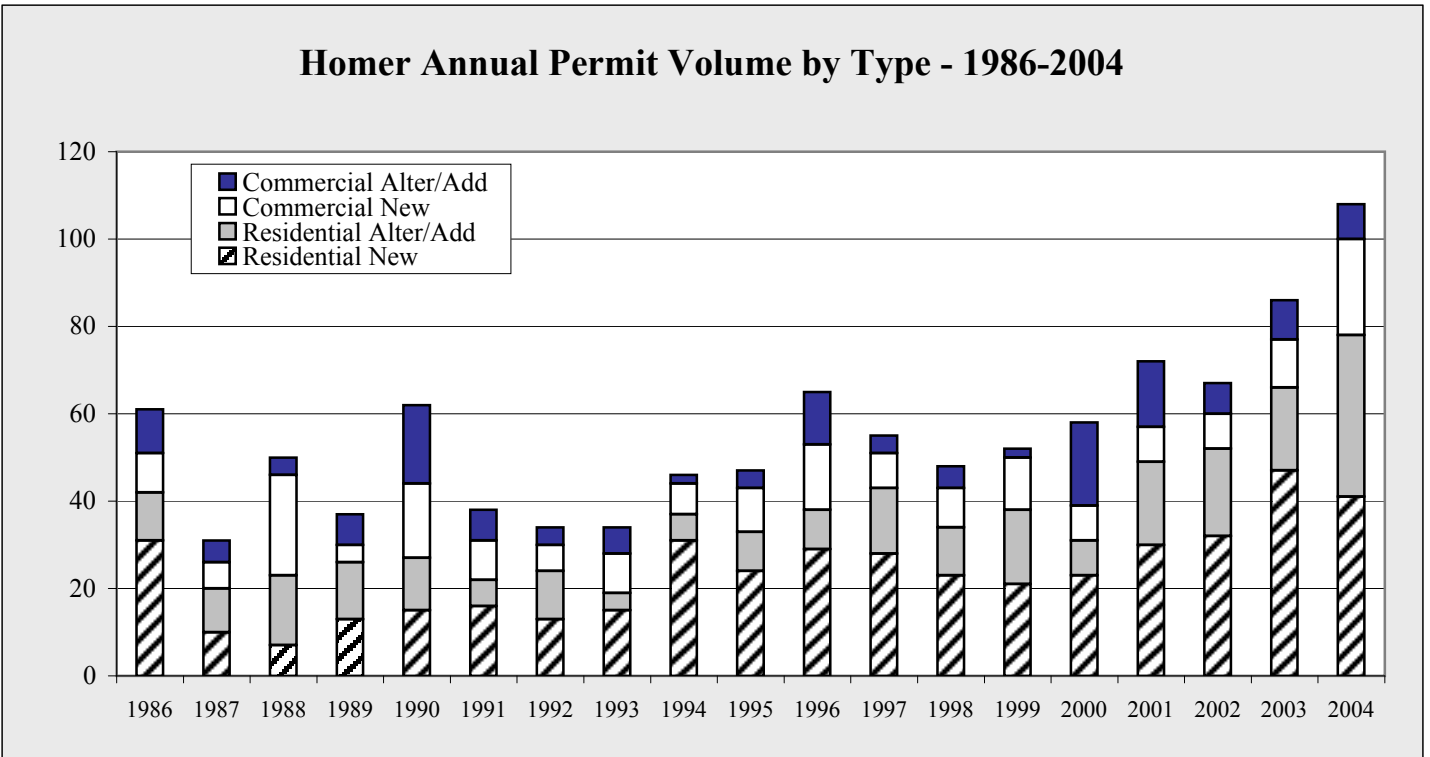

Chart 2.15

Homer Annual Permit Volume Percent by Type - 2004

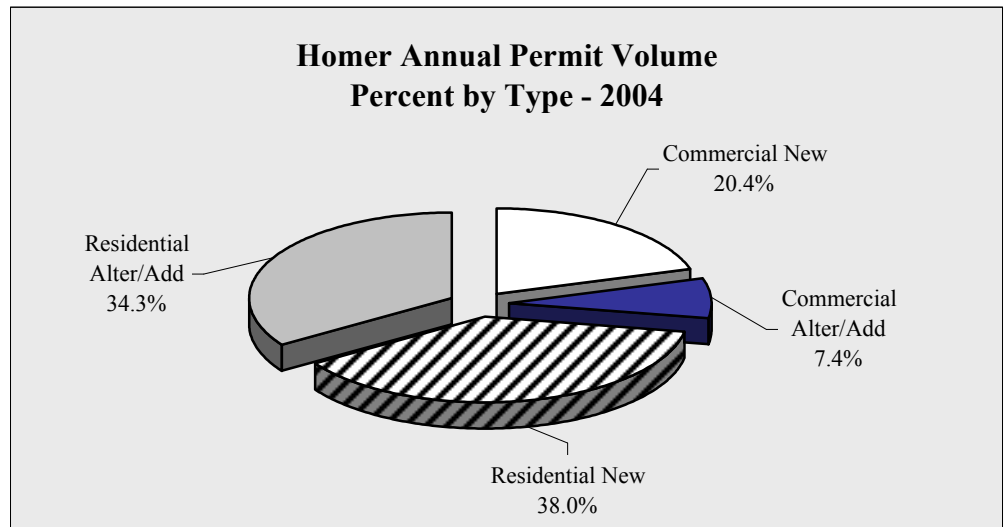

Chart 2.16

Homer Annual Permit Values by Quarter by Type - 1998-2005 - in \$

	1st Quarter	2nd Quarter	3rd Quarter	4th Quarter	Annual Total
1998					
Residential - New	594,000	875,000	620,000	761,750	2,850,750
Residential - Add/Alter	0	140,400	254,200	145,000	539,600
Commercial - New	35,970	1,192,036	41,019	1,259,000	2,528,025
Commercial - Add/Alter	0	66,500	175,000	40,000	281,500
TOTAL	629,970	2,273,936	1,090,219	2,205,750	6,199,875
1999					
Residential - New	1,673,000	1,038,000	740,000	195,000	3,646,000
Residential - Add/Alter	0	118,000	199,000	50,000	367,000
Commercial - New	270,000	1,520,000	4,800,000	316,000	6,906,000
Commercial - Add/Alter	0	15,000	6,000	0	21,000
TOTAL	1,943,000	2,691,000	5,745,000	561,000	10,940,000
2000					
Residential - New	392,600	867,440	1,025,000	326,000	2,611,040
Residential - Add/Alter	5,500	115,000	109,560	0	230,060
Commercial - New	85,000	725,480	805,000	48,000	1,663,480
Commercial - Add/Alter	1,315,000	558,000	207,410	543,982	2,624,392
TOTAL	1,798,100	2,265,920	2,146,970	917,982	7,128,972
2001					
Residential - New	300,000	2,093,800	1,161,680	492,300	4,047,780
Residential - Add/Alter	60,000	306,440	122,720	120,000	609,160
Commercial - New	285,000	1,485,800	340,000	300,000	2,410,800
Commercial - Add/Alter	45,000	216,000	1,371,950	11,100,000	12,732,950
TOTAL	690,000	4,102,040	2,996,350	12,012,300	19,800,690
2002					
Residential - New	891,760	1,308,460	1,466,300	560,200	4,226,720
Residential - Add/Alter	8,960	205,400	217,940	104,320	536,620
Commercial - New	0	1,000,000	3,912,740	78,000	4,990,740
Commercial - Add/Alter	28,000	14,349	180,350	72,000	294,699
TOTAL	928,720	2,528,209	5,777,330	814,520	10,048,779
2003					
Residential - New	979,800	3,811,480	2,106,275	1,222,900	8,120,455
Residential - Add/Alter	232,540	239,060	285,000	50,000	806,600
Commercial - New	0	3,535,720	628,800	1,600,000	5,764,520
Commercial - Add/Alter	122,000	343,240	0	170,000	635,240
TOTAL	1,334,340	7,929,500	3,020,075	3,042,900	15,326,815
2004					
Residential - New	2,597,500	2,495,400	1,225,600	377,000	6,695,500
Residential - Add/Alter	201,520	205,730	851,300	437,000	1,695,550
Commercial - New	915,000	4,700,518	6,225,000	2,560,000	14,400,518
Commercial - Add/Alter	0	32,063	1,230,000	17,000	1,279,063
TOTAL	3,714,020	7,433,711	9,531,900	3,391,000	24,070,631
2005					
	Year to Date				
Residential - New	1,694,400				1,694,400
Residential - Add/Alter	1,500				1,500
Commercial - New	108,000				108,000
Commercial - Add/Alter	1,302,000				1,302,000
TOTAL	3,105,900				3,105,900

Table 2.11

Homer Annual Permit Volume by Quarter by Type - 1998-2005					
	1st Quarter	2nd Quarter	3rd Quarter	4th Quarter	Annual Total
1998					
Residential - New	5	6	6	6	23
Residential - Add/Alter	0	4	5	2	11
Commercial - New	1	5	2	1	9
Commercial - Add/Alter	0	3	1	1	5
TOTAL	6	18	14	10	48
1999					
Residential - New	3	9	6	3	21
Residential - Add/Alter	0	4	11	2	17
Commercial - New	2	7	2	1	12
Commercial - Add/Alter	0	1	1	0	2
TOTAL	5	21	20	6	52
2000					
Residential - New	4	7	8	4	23
Residential - Add/Alter	1	2	5	0	8
Commercial - New	1	3	2	2	8
Commercial - Add/Alter	3	8	6	2	19
TOTAL	9	20	21	8	58
2001					
Residential - New	3	14	9	4	30
Residential - Add/Alter	1	12	4	2	19
Commercial - New	2	3	2	1	8
Commercial - Add/Alter	1	5	7	2	15
TOTAL	7	34	22	9	72
2002					
Residential - New	8	9	10	5	32
Residential - Add/Alter	1	5	8	6	20
Commercial - New	0	1	6	1	8
Commercial - Add/Alter	1	2	3	1	7
TOTAL	10	17	27	13	67
2003					
Residential - New	6	17	15	9	47
Residential - Add/Alter	8	6	3	2	19
Commercial - New	0	7	3	1	11
Commercial - Add/Alter	4	4	0	1	9
TOTAL	18	34	21	13	86
2004					
Residential - New	11	15	9	6	41
Residential - Add/Alter	2	5	21	9	37
Commercial - New	2	5	8	7	22
Commercial - Add/Alter	1	1	4	2	8
TOTAL	16	26	42	24	108
2005					
	Year to Date				
Residential - New	10				10
Residential - Add/Alter	1				1
Commercial - New	2				2
Commercial - Add/Alter	5				5
TOTAL	18				18

Table 2.12

Homer Cost of Food Survey

Cost of food data is collected by the University of Alaska, Fairbanks Cooperative Extension. Each quarter the Cooperative Extension surveys up to three grocers in communities throughout the state to determine the cost of food for one week. Specific guidelines are presented to the surveyors regarding item size and sale price for 104 items.

HOMER							
	March 2000	March 2001	March 2002	March 2003	March 2004	March 2005	Annual Change
Sales Tax (in percent)	5.5	5.5	5.5	5.5	5.5	5.5	
Percent of Food Unavailable	1.0	0.0	0.0	1.0	0.0	0.0	
Child 1 year	20.6	20.0	21.0	19.4	21.0	20.9	0.2%
Child 2 years	0.0	0.0	21.0	19.4	20.7	20.7	0.2%
Children 3-5 years	18.1	21.9	23.0	21.3	22.7	22.9	0.7%
Children 6-8 years	22.4	29.2	30.7	28.5	30.7	30.7	0.1%
Children 9-11 years	33.9	33.1	34.8	32.2	34.4	34.5	0.2%
Males 12-14 years	38.3	37.5	39.3	36.4	38.8	39.0	0.6%
Males 15-19 years	39.5	38.7	40.7	37.4	39.9	40.2	0.6%
Males 20-50 years	39.2	38.6	40.7	37.5	40.0	40.3	0.5%
Males 51 years & over	37.4	36.7	38.7	35.7	38.2	38.4	0.5%
Females 12-19 years	33.1	32.3	34.0	31.3	33.6	33.8	0.6%
Females 20-50 years	34.3	33.7	35.6	32.8	35.0	35.1	0.3%
Females 51 years and over	33.3	32.8	34.6	31.9	33.9	34.2	0.6%
Family of 2 (20-50 years)	80.8	79.6	83.8	77.4	82.5	82.9	0.4%
Family of 2 (51 & older)	77.7	76.5	80.7	74.4	79.4	79.8	0.6%
Family of 4 children 1-5 years	116.6	114.3	120.2	111.1	118.4	119.0	0.4%
Family of 4 children 6-11 years	137.4	134.7	141.7	131.0	140.1	140.5	0.3%
Electricity, 1000 kWh	103.5	112.4	118.9	124.7	101.3	115.9	14.4%
Heating oil, 55 gal		75.9	56.7	82.0	88.6	120.5	36.0%
Gas-55 gal unleaded auto		99.0	85.2	105.0	103.4	117.1	13.3%
Lumber, 2X4X8'		2.6	3.1	2.7	3.3	3.6	9.4%
Propane, 100 LB refill		38.7	38.7	42.2	45.8	52.8	15.3%

Table 2.13

Homer Cost of Food Survey

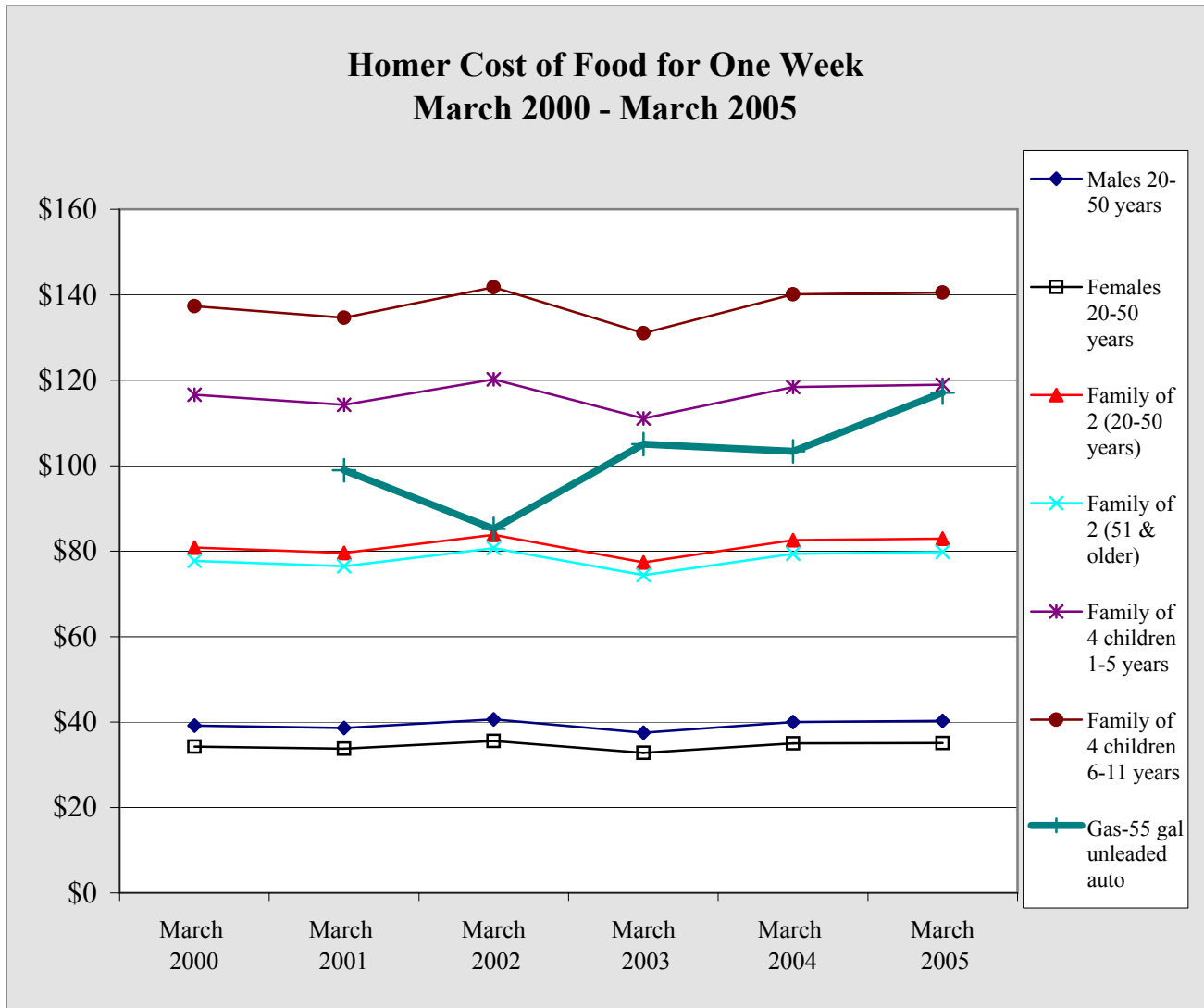

Chart 2.17

* Data for 1999 not available

* Gas Price for 2000 not available

Homer Select Data 1990-2000 **Homer Population**

Population					Housing				
	1990	2000	Percent Change	Percent of Total		1990	2000	Percent Change	Percent of Total
Total Population	3,660	3,946	7.8%	100.0%	Total Households	1,411	1,599	13.3%	100.0%
Male	1,869	1,951	4.4%	49.4%	Family Households	912	1,009	10.6%	63.1%
Female	1,791	1,995	11.4%	50.6%	With Children Under 18		553	NA	34.6%
Under 5 years	333	254	-23.7%	6.4%	Married Couple Family	706	772	9.3%	48.3%
5 to 9 years	346	297	-14.2%	7.5%	With Own Children Under 18		381	NA	23.8%
10 to 14 years	277	327	18.1%	8.3%	Female Householder, no husband present		162	NA	10.1%
15 to 19 years	234	319	36.3%	8.1%	With Own Children Under 18		123	NA	7.7%
20 to 24 years	172	177	2.9%	4.5%	Average Household Size	2.54	2.40	NA	0.2%
25 to 34 years	672	401	-40.3%	10.2%	Average Family Size		2.99	NA	0.2%
35 to 44 years	774	659	-14.9%	16.7%	Total Housing Units	1,673	1,873	NA	117.1%
45 to 54 years	389	748	92.3%	19.0%	Occupied Housing Units	1,411	1,599	13.3%	100.0%
55 to 59 years	108	223	106.5%	5.7%	Vacant Housing Units	262	274	4.6%	17.1%
60 to 64 years	95	143	50.5%	3.6%	Seasonal, Recreational, Occasional Use	65	129	98.5%	8.1%
65 to 74 years	172	207	20.3%	5.2%	Owner Vacancy Rate		2.9%	NA	NA
75 to 84 years	72	143	98.6%	3.6%	Rental Vacancy Rate		10.9%	NA	NA
85 years and over	16	48	200.0%	1.2%	Owner Occupied Units	763	987	29.4%	61.7%
Median Age	32.4	38.8	19.8%	NA	Renter Occupied Units	648	612	-5.6%	38.3%
18 Years and Over	1,111	2,857	157.2%	72.4%	Marital Status (over 15)		3,071	NA	NA
Male	NA	1,419	NA	NA	Never married		719	NA	23.4%
Female	NA	1,438	NA	NA	Married except separated		1,722	NA	56.1%
65 Years and Over	260	398	53.1%	10.1%	Separated		60	NA	2.0%
Male	NA	182	NA	NA	Widowed		111	NA	3.6%
Female	NA	216	NA	NA	Divorced		459	NA	14.9%
Place of Birth					Disabled, Noninstitutionalized				
Native Born	3,559	3,813	7.1%	96.6%	Population 5 to 20		988	NA	100.0%
Born in Alaska		1,190	NA	30.2%	With a Disability		37	NA	3.7%
Born in other state		2,581	NA	65.4%	Population 21 to 64		2,242	NA	100.0%
Foreign Born	101	141	39.6%	3.6%	With a Disability		362	NA	16.1%
Naturalized Citizen		99	NA	2.5%	Percent Employed		50.0%	NA	0.0%
Not a Citizen		42	NA	1.1%	Without a Disability		1,880	NA	83.9%
Veteran Status					Percent Employed		75.7%	NA	0.0%
Civilian veterans	472	454	NA	16.4%	Income in 1999 - Families				
Educational Attainment						Total	1008		
Population 25 years and over				2,564	Less than \$10,000	53	46	-13.2%	4.6%
Less than 9th grade	61	35	-42.6%	1.4%	\$10,000 - \$14,999	70	38	-45.7%	3.8%
9th-12th, no diploma	204	16	-92.2%	0.6%	\$15,000 - \$24,999	122	100	-18.0%	9.9%
High School Diploma	671	660	-1.6%	25.7%	\$25,000 - \$34,999	127	93	-26.8%	9.2%
College, no degree	601	829	37.9%	32.3%	\$35,000 - \$49,999	151	182	20.5%	18.1%
Associate Degree	163	132	-19.0%	5.1%	\$50,000 - \$74,999	215	261	21.4%	25.9%
Bachelor's Degree	467	474	1.5%	18.5%	\$75,000 - \$99,999	89	145	62.9%	14.4%
Graduate, Profess Degree	131	274	109.2%	10.7%	\$100,000 - \$149,999	64	107	67.2%	10.6%
Percent HS Grad	88.5%	92.4%	4.4%	0.0%	\$150,000 - \$199,999	30	17	-43.3%	1.7%
Percent Bachelor's +	26.0%	29.2%	12.3%	0.0%	\$200,000 or more	NA	19	NA	1.9%
					Median Income - \$	42,824	53,571	25.1%	NA

Table 2.14

Kenai 1st Quarter Gross Sales by Industry - 1999-2005 - in \$								
	1999	2000	2001	2002	2003	2004	2005	Annual Change
AFF	629,110	1,289,933	633,357	1,170,314	1,002,650	1,061,786	1,613,553	52.0%
Min	37,476	1,537,438	852,594	2,214,717	942,570	2,011,733	2,243,621	11.5%
Const	3,055,890	3,678,541	1,914,204	3,777,071	4,115,296	2,314,222	1,901,453	-17.8%
Manu	1,475,182	2,268,724	2,808,918	2,256,153	2,997,006	1,610,022	1,676,345	4.1%
TCPU	6,364,713	6,312,579	6,078,860	6,416,059	7,714,369	6,489,016	20,301,148	212.9%
Whole	1,912,703	2,723,434	4,987,946	3,364,888	3,221,739	5,349,782	4,968,831	-7.1%
Retail	27,061,077	27,945,524	34,150,036	28,474,145	30,107,230	29,814,280	30,440,005	2.1%
FIRE	2,650,247	2,518,820	2,962,348	3,439,155	3,050,602	2,864,673	2,536,399	-11.5%
Service	6,123,394	7,334,383	8,030,023	9,483,867	8,988,895	9,556,990	8,905,923	-6.8%
Govt	105	200	0	0	0	0	0	NA
Total	49,309,897	55,609,576	62,418,286	60,596,369	62,140,357	61,072,504	74,587,278	22.1%
Annual Change		12.8%	12.2%	-2.9%	2.5%	-1.7%	22.1%	

Table 3.1

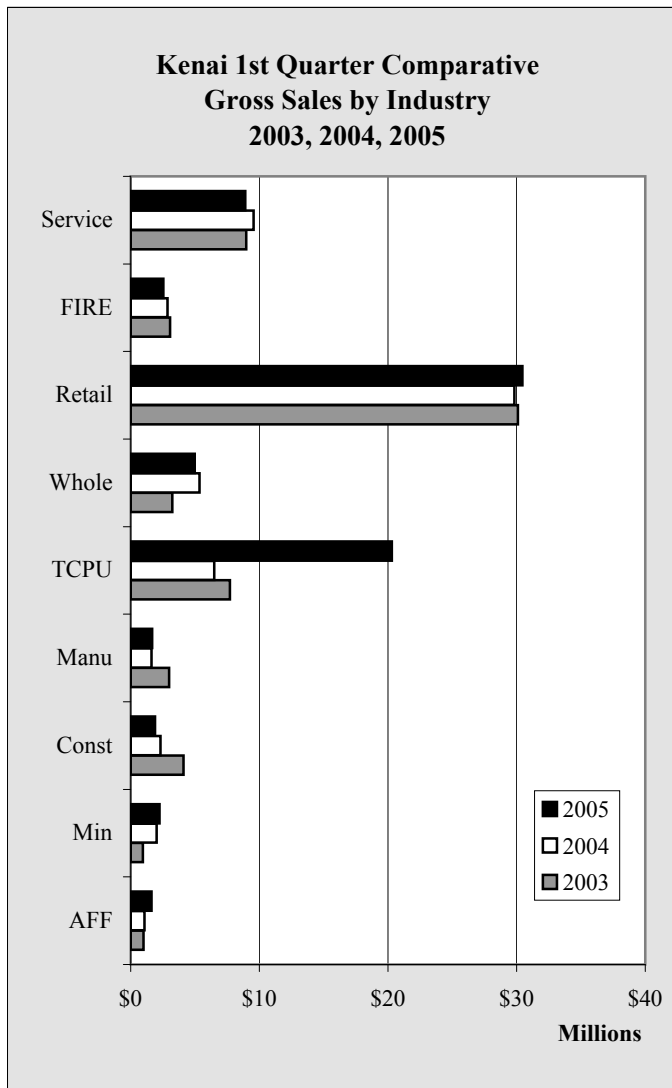

Chart 3.1

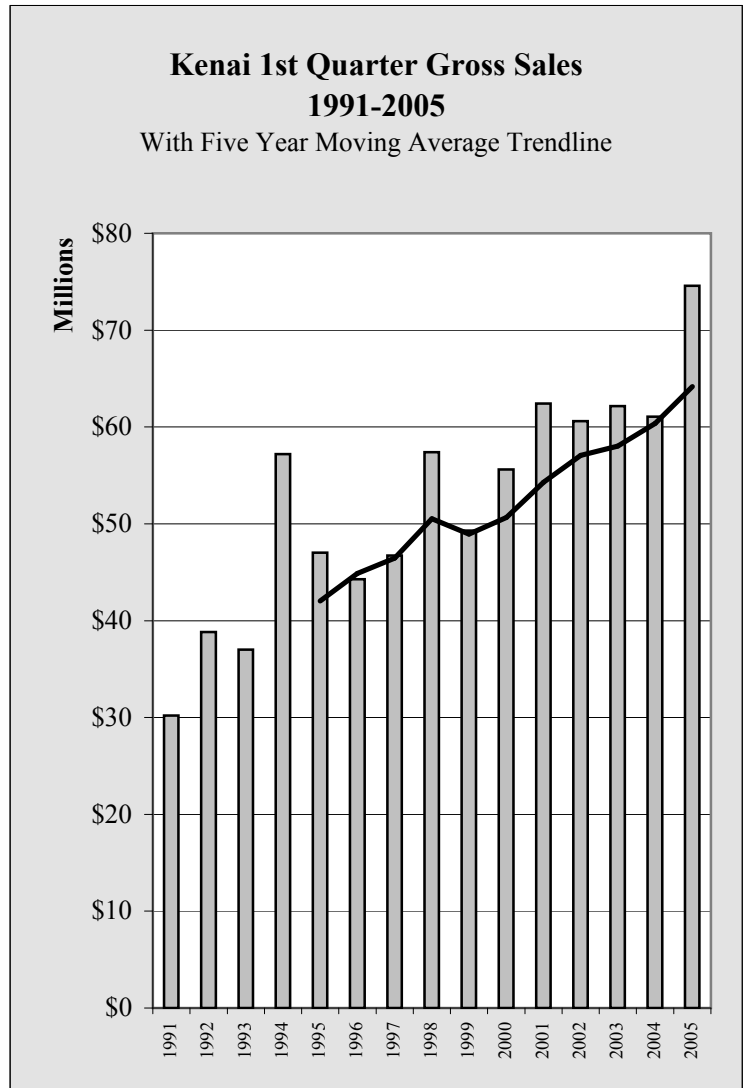

Chart 3.2

Kenai 1st Quarter Taxable Sales by Industry - 1999-2005 - in \$								
	1999	2000	2001	2002	2003	2004	2005	Annual Change
AFF	99,230	79,672	88,262	90,609	87,894	97,275	141,622	45.6%
Min	7,264	30,513	58,812	51,370	34,119	63,827	70,218	10.0%
Const	257,031	234,824	237,187	248,573	242,193	270,414	192,533	-28.8%
Manu	356,148	436,177	437,740	349,360	441,292	508,762	434,079	-14.7%
TCPU	3,587,280	3,661,405	3,398,397	3,779,839	4,932,006	3,939,435	3,890,462	-1.2%
Whole	168,481	182,229	179,452	107,790	79,538	152,309	90,018	-40.9%
Retail	16,109,907	16,163,284	18,137,349	18,685,738	20,062,767	19,316,910	19,538,827	1.1%
FIRE	1,204,578	1,230,731	1,527,679	1,645,401	1,480,683	1,256,343	1,107,224	-11.9%
Service	3,393,873	3,502,478	3,824,363	3,979,662	3,732,984	3,940,716	3,771,696	-4.3%
Govt	105	200	0	0	0	0	0	NA
Total	25,183,897	25,521,513	27,889,241	28,938,342	31,093,476	29,545,991	29,236,679	-1.0%
Annual Change		1.3%	9.3%	3.8%	7.4%	-5.0%	-1.0%	

Table 3.2

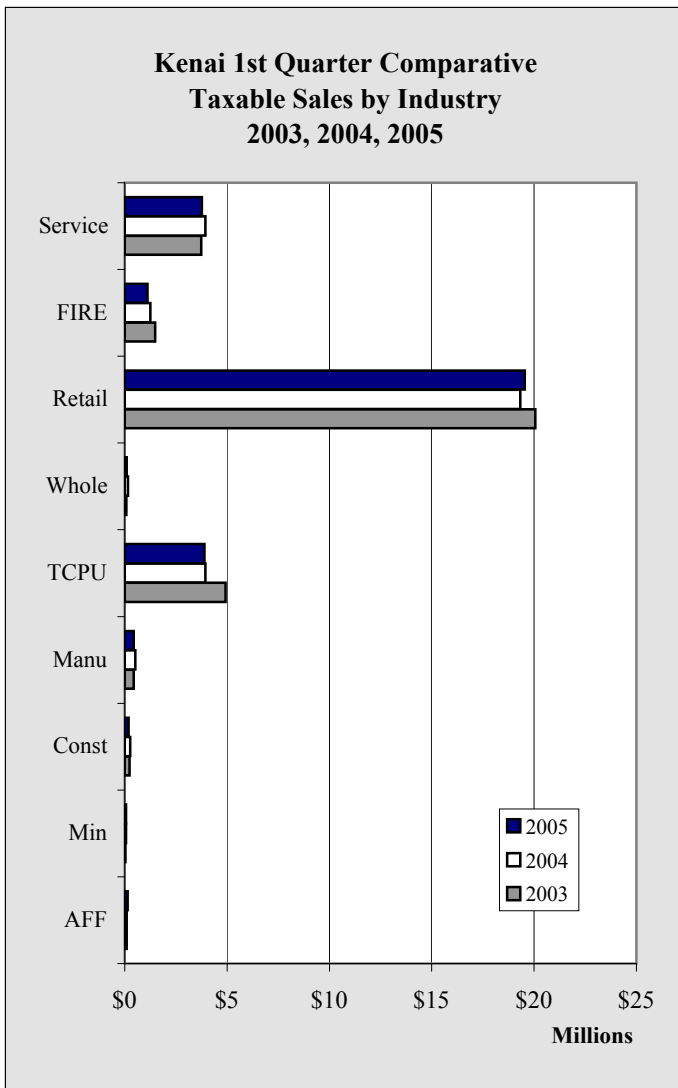

Chart 3.3

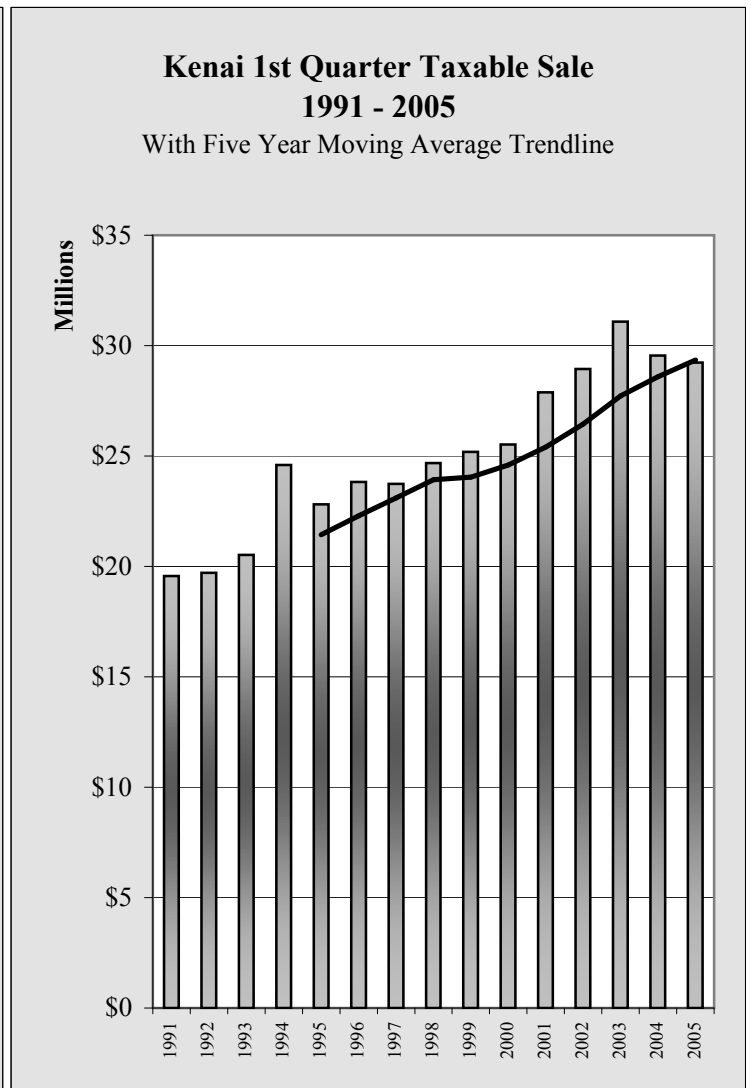

Chart 3.4

Kenai Sales

Kenai Annual Gross Sales by Industry - 1998-2004 - in \$

	1998	1999	2000	2001	2002	2003	2004	Annual Change
AFF	21,856,770	27,031,481	17,757,626	11,304,090	9,488,174	12,584,181	16,349,894	29.9%
Min	208,531	1,424,691	5,507,130	2,507,234	3,916,074	4,915,930	8,727,840	77.5%
Const	21,481,466	20,692,714	17,177,398	24,151,985	18,522,782	30,636,346	12,902,345	-57.9%
Manu	7,526,545	7,854,159	10,445,806	12,646,047	12,496,147	14,994,862	9,506,441	-36.6%
TCPU	23,017,785	26,815,943	23,883,929	24,107,421	27,762,814	24,667,417	29,890,326	21.2%
Whole	10,194,981	10,520,958	17,902,155	19,965,613	17,521,629	19,037,117	187,702,003	886.0%
Retail	149,397,570	133,272,201	145,306,370	164,046,542	134,565,667	119,219,213	146,045,543	22.5%
FIRE	10,300,066	10,463,600	11,935,000	13,853,920	13,529,801	12,784,912	12,915,093	1.0%
Service	36,094,281	32,669,956	33,766,762	37,842,360	41,942,315	44,500,264	45,260,749	1.7%
Govt	1,945	415	288	1,213	0	0	0	NA
Total	280,079,940	270,746,118	283,682,464	310,426,425	279,745,403	283,340,242	469,300,234	65.6%
Annual Change		-3.3%	4.8%	9.4%	-9.9%	1.3%	65.6%	

Table 3.3

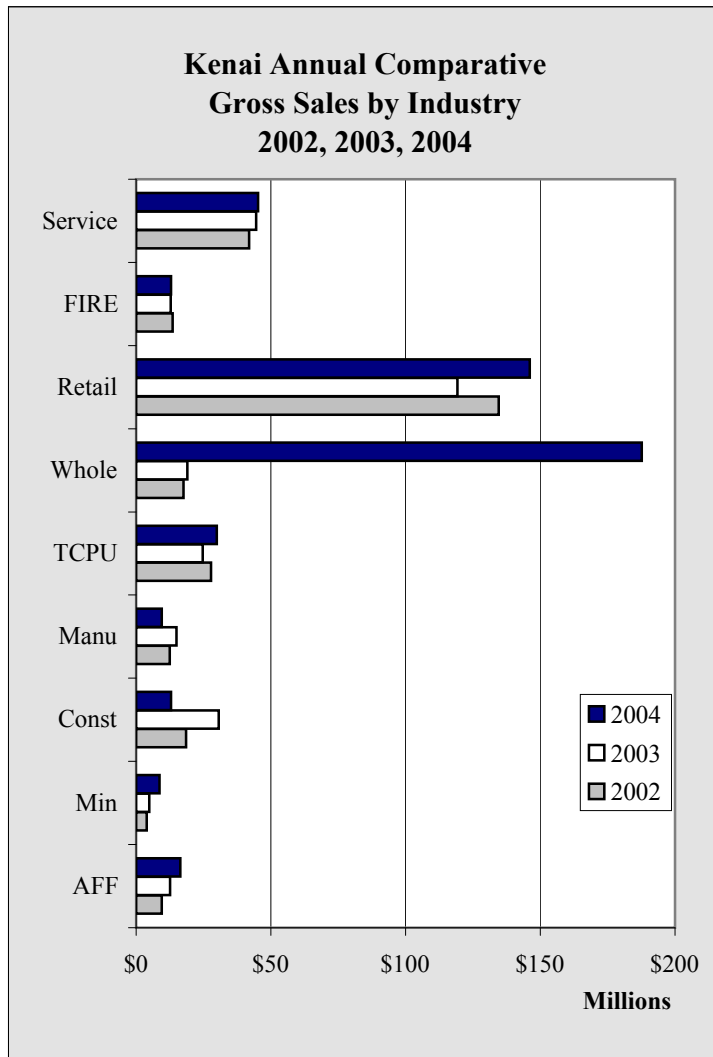

Chart 3.5

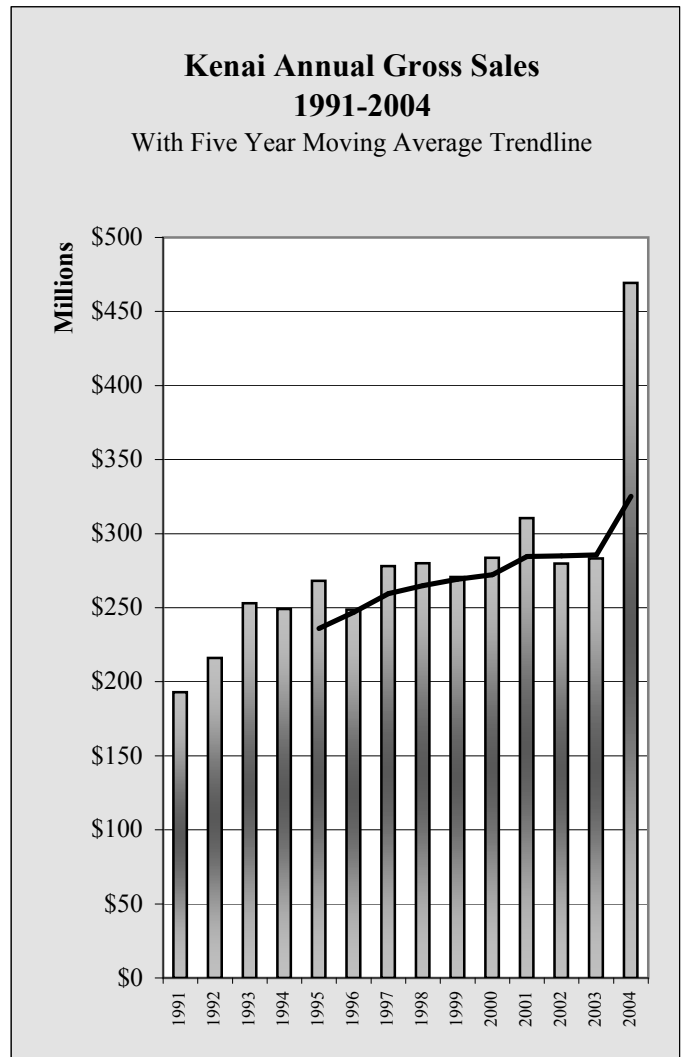

Chart 3.6

Kenai Sales

Kenai Annual Taxable Sales by Industry - 1998-2004 - in \$

	1998	1999	2000	2001	2002	2003	2004	Annual Change
AFF	448,689	513,026	518,603	505,615	505,614	559,313	718,415	28.4%
Min	49,522	96,651	166,846	223,196	213,971	192,718	262,963	36.4%
Const	1,200,303	1,180,607	1,085,964	1,171,924	1,111,101	1,172,308	1,146,165	-2.2%
Manu	2,140,912	2,085,657	2,450,721	2,238,645	2,218,515	2,451,929	2,853,082	16.4%
TCPU	12,899,378	15,330,911	13,458,834	13,192,948	16,120,066	15,890,944	14,094,256	-11.3%
Whole	877,088	829,682	898,759	727,784	517,025	494,254	473,716	-4.2%
Retail	80,814,442	81,828,974	85,347,467	93,226,651	90,195,938	76,153,080	94,195,956	23.7%
FIRE	4,918,254	4,824,067	5,718,387	6,757,340	6,600,246	5,601,342	5,209,124	-7.0%
Service	16,680,181	17,677,101	18,120,257	18,998,608	19,287,134	18,796,331	19,673,769	4.7%
Govt	1,938	415	288	1,213	0	0	0	NA
Total	120,030,707	124,367,091	127,766,126	137,043,924	136,769,610	121,312,219	138,627,446	14.3%
Annual Change		3.6%	2.7%	7.3%	-0.2%	-11.3%	14.3%	

Table 3.4

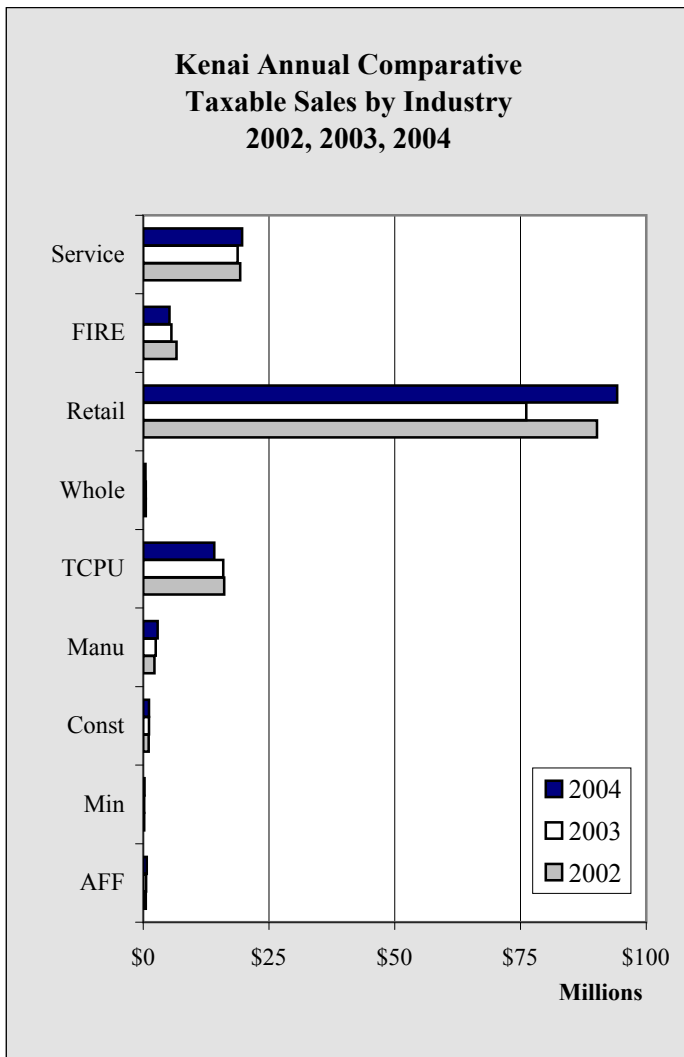

Chart 3.7

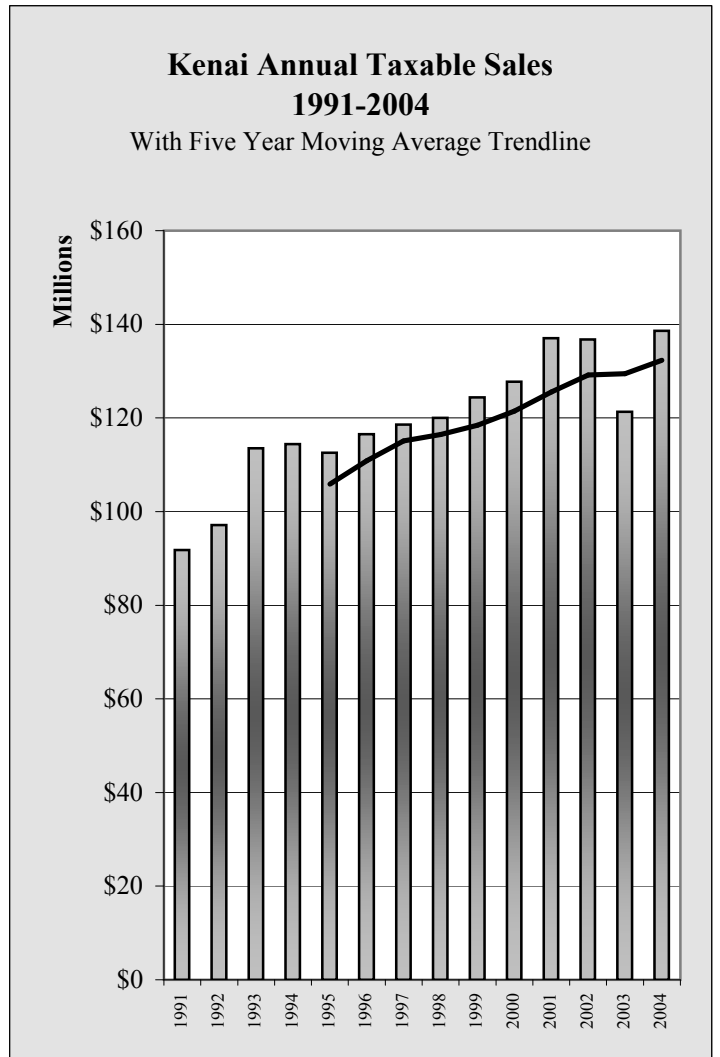

Chart 3.8

Kenai Sales

Kenai Gross Sales by Industry by Quarter - 2002-2005 - in \$					
	1st Quarter	2nd Quarter	3rd Quarter	4th Quarter	Total
2002					
AFF	1,170,314	810,865	7,279,641	227,354	9,488,174
Min	2,214,717	516,408	805,341	379,608	3,916,074
Const	3,777,071	4,295,333	4,991,407	5,458,971	18,522,782
Manu	2,256,153	3,007,187	3,464,827	3,767,980	12,496,147
TCPU	6,416,059	6,155,532	8,070,497	7,120,726	27,762,814
Whole	3,364,888	4,677,095	5,410,024	4,069,622	17,521,629
Retail	28,474,145	34,741,208	36,679,657	34,670,657	134,565,667
FIRE	3,439,155	3,667,615	3,373,799	3,049,232	13,529,801
Service	9,483,867	10,058,048	12,526,446	9,873,954	41,942,315
Govt	0	0	0	0	0
Total	60,596,369	67,929,291	82,601,639	68,618,104	279,745,403
2003					
AFF	1,002,650	838,734	10,272,676	470,121	12,584,181
Min	942,570	872,788	1,517,115	1,583,457	4,915,930
Const	4,115,296	6,454,835	7,865,523	12,200,692	30,636,346
Manu	2,997,006	4,210,293	5,529,544	2,258,019	14,994,862
TCPU	7,714,369	6,152,058	4,859,475	5,941,515	24,667,417
Whole	3,221,739	4,841,740	5,639,800	5,333,838	19,037,117
Retail	30,107,230	28,949,996	30,099,399	30,062,588	119,219,213
FIRE	3,050,602	3,256,374	3,127,817	3,350,119	12,784,912
Service	8,988,895	11,847,481	12,318,427	11,345,461	44,500,264
Govt	0	0	0	0	0
Total	62,140,357	67,424,299	81,229,776	72,545,810	283,340,242
2004					
AFF	1,061,786	1,296,885	12,241,519	1,749,704	16,349,894
Min	2,011,733	2,172,358	2,186,041	2,357,708	8,727,840
Const	2,314,222	2,769,875	3,622,703	4,195,545	12,902,345
Manu	1,610,022	3,062,848	2,757,875	2,075,696	9,506,441
TCPU	6,489,016	5,560,861	11,816,038	6,024,411	29,890,326
Whole	5,349,782	5,842,357	7,155,295	169,354,569	187,702,003
Retail	29,814,280	39,251,887	40,496,449	36,482,927	146,045,543
FIRE	2,864,673	3,219,231	3,430,855	3,400,334	12,915,093
Service	9,556,990	11,101,534	14,133,524	10,468,701	45,260,749
Govt	0	0	0	0	0
Total	61,072,504	74,277,836	97,840,299	236,109,595	469,300,234
2005					Year to Date
AFF	1,613,553				1,613,553
Min	2,243,621				2,243,621
Const	1,901,453				1,901,453
Manu	1,676,345				1,676,345
TCPU	20,301,148				20,301,148
Whole	4,968,831				4,968,831
Retail	30,440,005				30,440,005
FIRE	2,536,399				2,536,399
Service	8,905,923				8,905,923
Govt	0				0
Total	74,587,278				74,587,278

Table 3.5

Kenai Sales

Kenai Taxable Sales by Industry by Quarter - 2002-2005 - in \$					
	1st Quarter	2nd Quarter	3rd Quarter	4th Quarter	Total
2002					
AFF	90,609	128,556	200,238	86,211	505,614
Min	51,370	57,479	52,898	52,224	213,971
Const	248,573	273,401	292,612	296,515	1,111,101
Manu	349,360	622,875	754,966	491,314	2,218,515
TCPU	3,779,839	3,794,883	4,235,801	4,309,543	16,120,066
Whole	107,790	146,986	138,933	123,316	517,025
Retail	18,685,738	22,876,325	24,650,115	23,983,760	90,195,938
FIRE	1,645,401	1,684,226	1,706,454	1,564,165	6,600,246
Service	3,979,662	5,064,834	6,160,963	4,081,675	19,287,134
Govt	0	0	0	0	0
Total	28,938,342	34,649,565	38,192,980	34,988,723	136,769,610
2003					
AFF	87,894	134,783	237,344	99,292	559,313
Min	34,119	46,723	51,411	60,465	192,718
Const	242,193	295,969	316,506	317,640	1,172,308
Manu	441,292	687,335	816,883	506,419	2,451,929
TCPU	4,932,006	4,056,076	3,270,630	3,632,232	15,890,944
Whole	79,538	111,864	145,387	157,465	494,254
Retail	20,062,767	18,246,087	19,174,865	18,669,361	76,153,080
FIRE	1,480,683	1,494,804	1,373,022	1,252,833	5,601,342
Service	3,732,984	4,727,913	5,965,690	4,369,744	18,796,331
Govt	0	0	0	0	0
Total	31,093,476	29,801,554	31,351,738	29,065,451	121,312,219
2004					
AFF	97,275	159,363	351,638	110,139	718,415
Min	63,827	57,575	75,540	66,021	262,963
Const	270,414	294,583	308,561	272,607	1,146,165
Manu	508,762	803,910	1,023,087	517,323	2,853,082
TCPU	3,939,435	3,467,903	3,197,445	3,489,473	14,094,256
Whole	152,309	127,610	109,725	84,072	473,716
Retail	19,316,910	25,145,460	26,970,841	22,762,745	94,195,956
FIRE	1,256,343	1,345,408	1,362,338	1,245,035	5,209,124
Service	3,940,716	4,853,058	6,633,379	4,246,616	19,673,769
Govt	0	0	0	0	0
Total	29,545,991	36,254,870	40,032,554	32,794,031	138,627,446
2005					
	Year to Date				
AFF	141,622				141,622
Min	70,218				70,218
Const	192,533				192,533
Manu	434,079				434,079
TCPU	3,890,462				3,890,462
Whole	90,018				90,018
Retail	19,538,827				19,538,827
FIRE	1,107,224				1,107,224
Service	3,771,696				3,771,696
Govt	0				0
Total	29,236,679				29,236,679

Table 3.6

Kenai Construction Permitting

Kenai 1st Quarter Permit Values by Type - 1999-2005 - in \$

	1999	2000	2001	2002	2003	2004	2005	Annual Change
Residential - New	0	228,000	623,000	279,000	0	300,000	0	NA
Residential - Add/Alter	122,000	7,000	161,500	28,000	15,000	12,000	134,500	1020.8%
Commercial - New	14,500	65,000	15,000	3,579,200	0	0	0	NA
Commercial - Add/Alter	103,000	162,900	20,000	2,000	1,542,600	0	291,000	NA
TOTAL	239,500	462,900	819,500	3,888,200	1,557,600	312,000	425,500	36.4%
Annual Change		93.3%	77.0%	374.5%	-59.9%	-80.0%	36.4%	

Table 3.7

Kenai 1st Quarter Permit Values by Type - 1986-2005

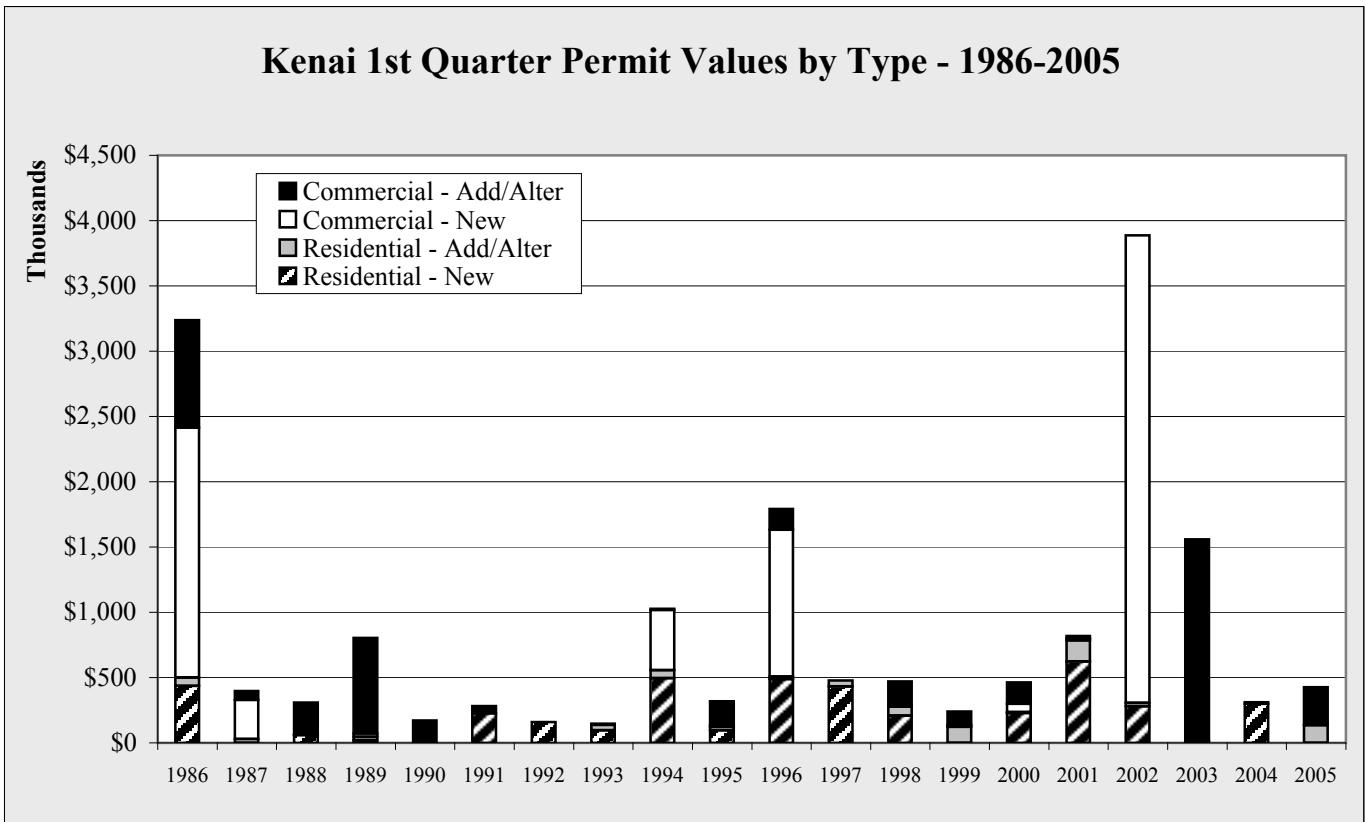

Chart 3.9

Kenai 1st Quarter Permit Value Percent by Type - 2005

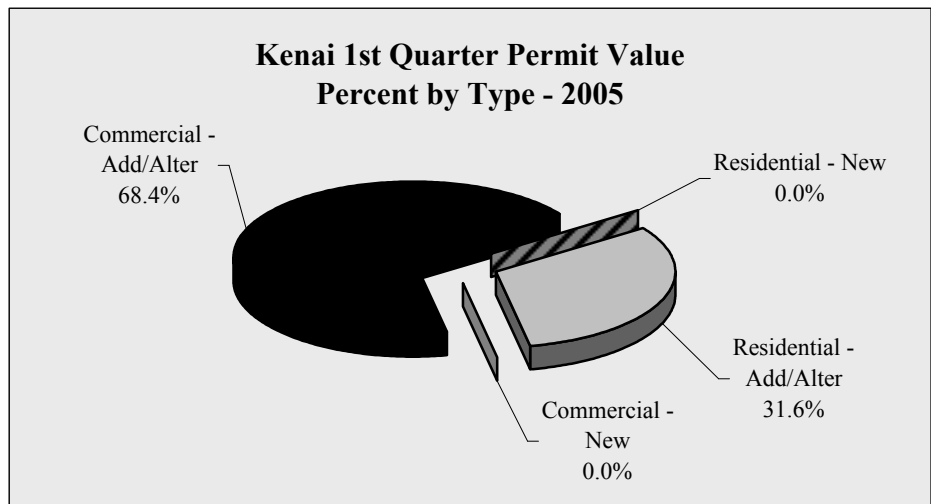

Chart 3.10

Kenai Construction Permitting

Kenai 1st Quarter Permit Volume by Type - 1999-2005

	1999	2000	2001	2002	2003	2004	2005	Annual Change
Residential - New	3	2	5	1	1	1	0	-100.0%
Residential - Add/Alter	1	1	1	1	0	0	7	NA
Commercial - New	3	4	1	1	7	0	0	NA
Commercial - Add/Alter	7	8	11	5	8	4	3	-25.0%
TOTAL	14	15	18	8	16	5	10	100.0%
Annual Change		7.1%	20.0%	-55.6%	100.0%	-68.8%	100.0%	

Table 3.8

Kenai 1st Quarter Permit Volume by Type - 1986-2005

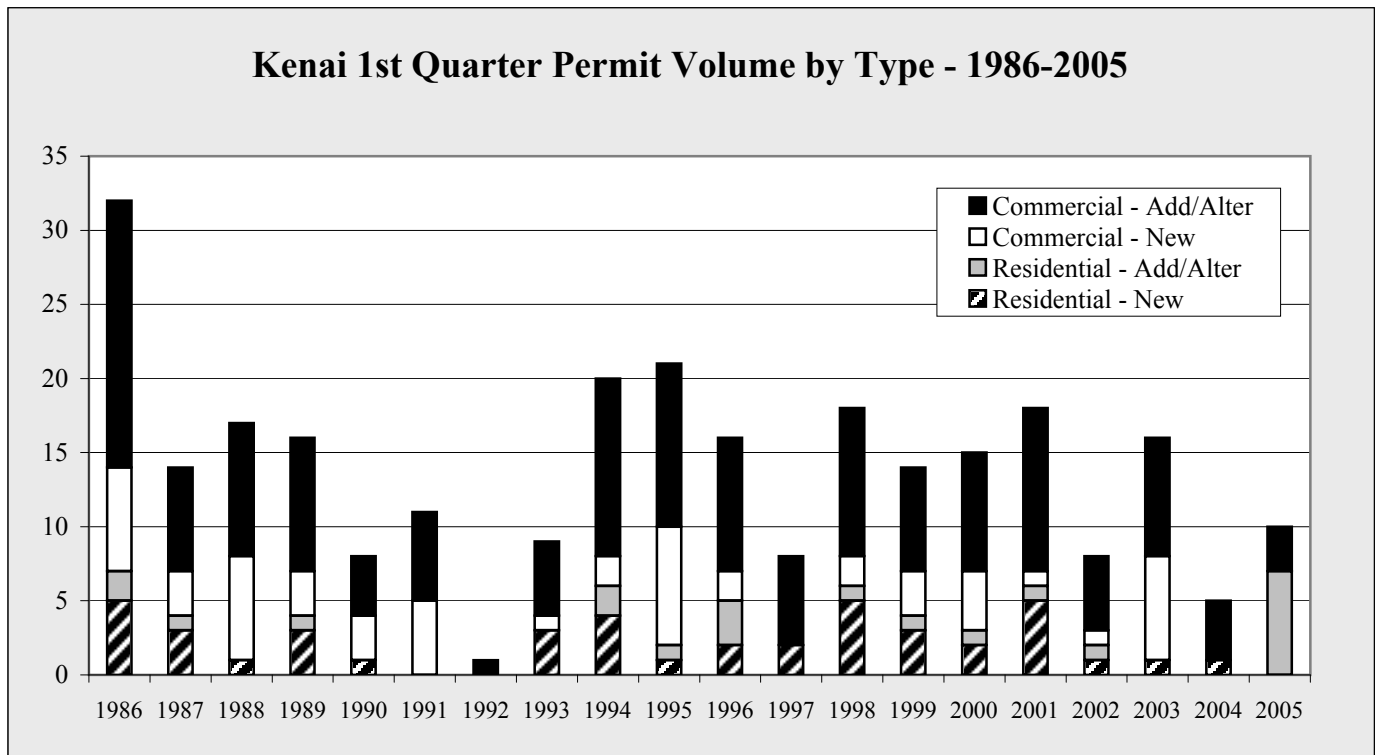

Chart 3.11

Kenai 1st Quarter Permit Volume Percent by Type - 2005

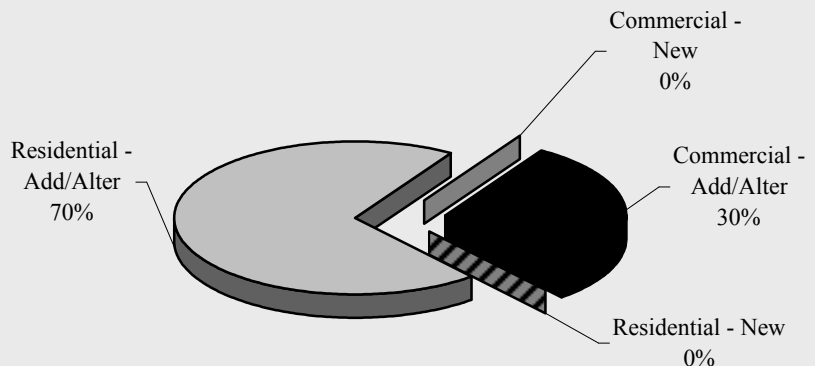

Chart 3.12

Kenai Construction Permitting

Kenai Annual Permit Values by Type - 1998-2004 - in \$

	1998	1999	2000	2001	2002	2003	2004	Annual Change
Residential - New	6,033,500	3,324,000	3,497,000	4,985,000	5,917,000	3,282,000	3,058,500	-6.8%
Residential - Add/Alter	730,700	798,000	888,400	675,100	723,500	882,050	400,150	-54.6%
Commercial - New	151,000	4,797,750	4,250,000	5,379,700	6,261,200	304,000	331,000	8.9%
Commercial - Add/Alter	727,000	522,000	762,700	2,539,100	3,897,700	5,973,750	996,900	-83.3%
TOTAL	7,642,200	9,441,750	9,398,100	13,578,900	16,799,400	10,441,800	4,786,550	-54.2%
Annual Change		23.5%	-0.5%	44.5%	23.7%	-37.8%	-54.2%	

Table 3.9

Kenai Annual Permit Values by Type - 1986-2004

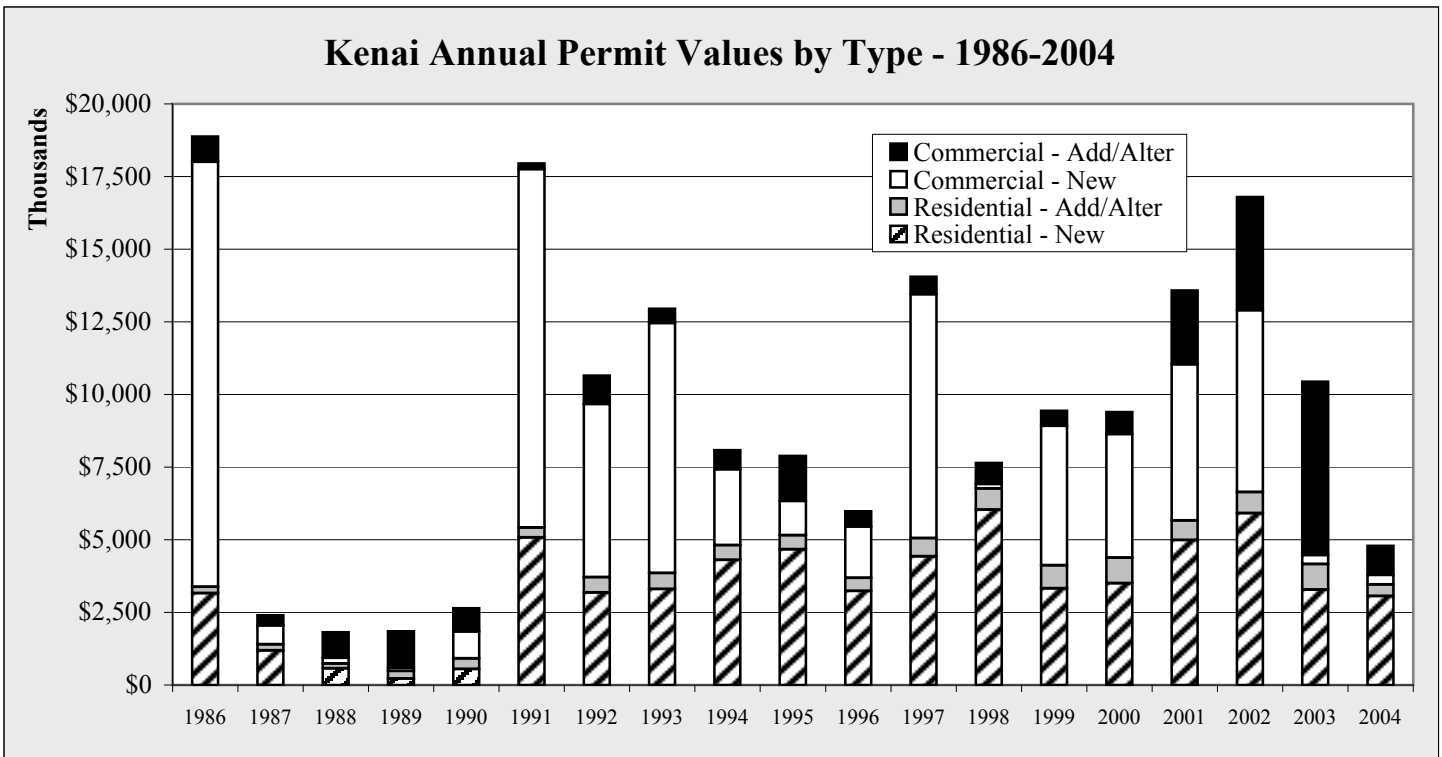

Chart 3.13

Kenai Annual Permit Values
Percent by Type - 2004

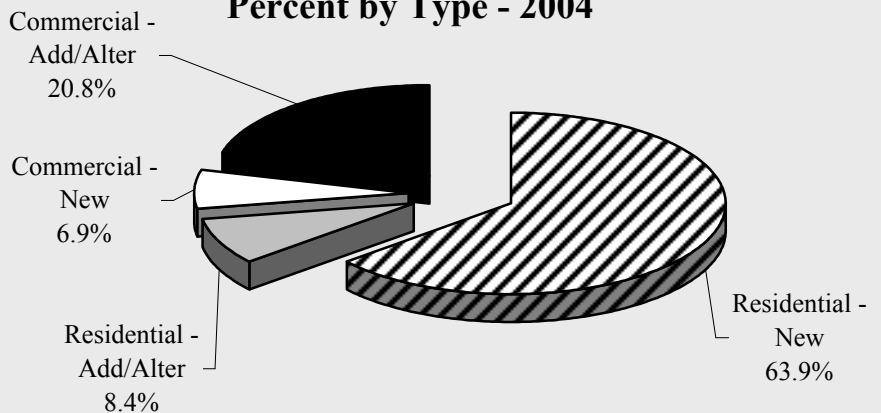

Chart 3.14

Kenai Construction Permitting

Kenai Annual Permit Volume by Type - 1998-2004

	1998	1999	2000	2001	2002	2003	2004	Annual Change
Residential - New	45	26	26	30	42	22	20	-9.1%
Residential - Add/Alter	33	41	45	31	45	44	25	-43.2%
Commercial - New	4	13	11	8	9	4	3	-25.0%
Commercial - Add/Alter	15	22	11	18	25	44	31	-29.5%
TOTAL	97	102	93	87	121	114	79	-30.7%
Annual Change		5.2%	-8.8%	-6.5%	39.1%	-5.8%	-30.7%	

Table 3.10

Kenai Annual Permit Volume by Type - 1986-2004

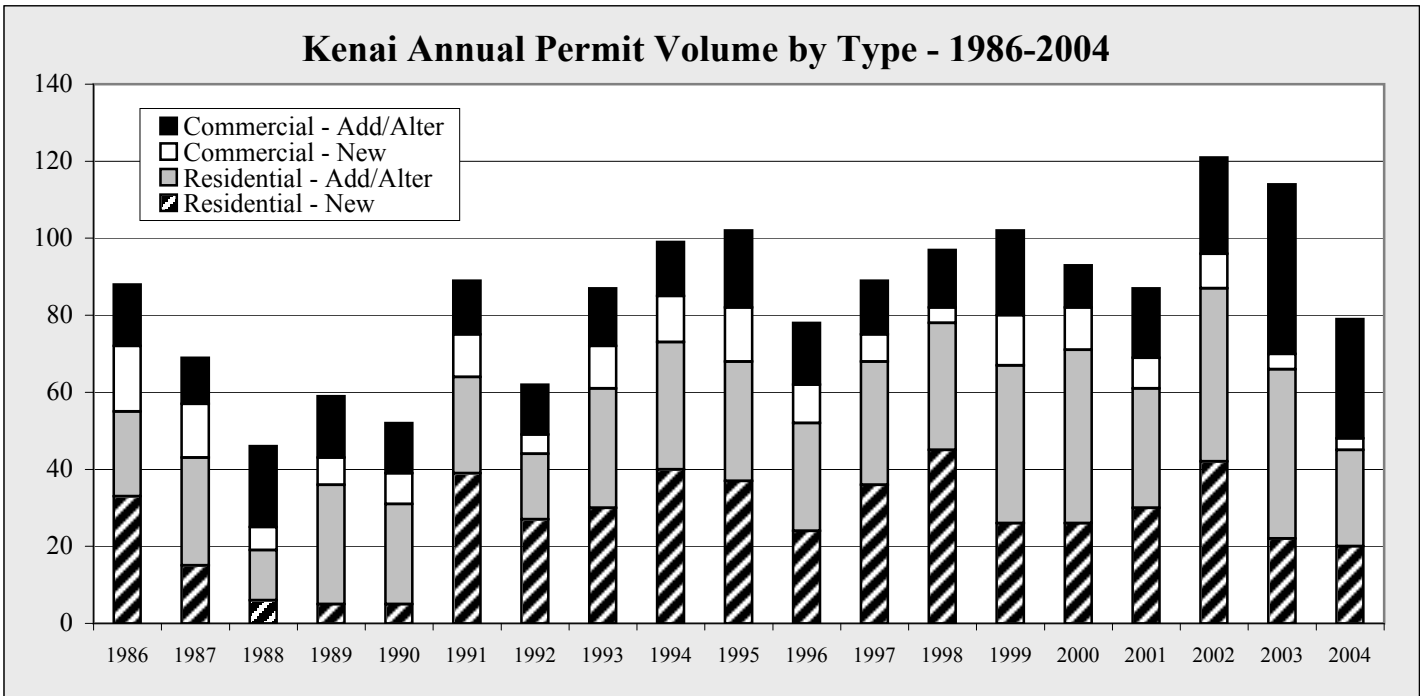

Chart 3.15

Kenai Annual Permit Volume Percent by Type - 2004

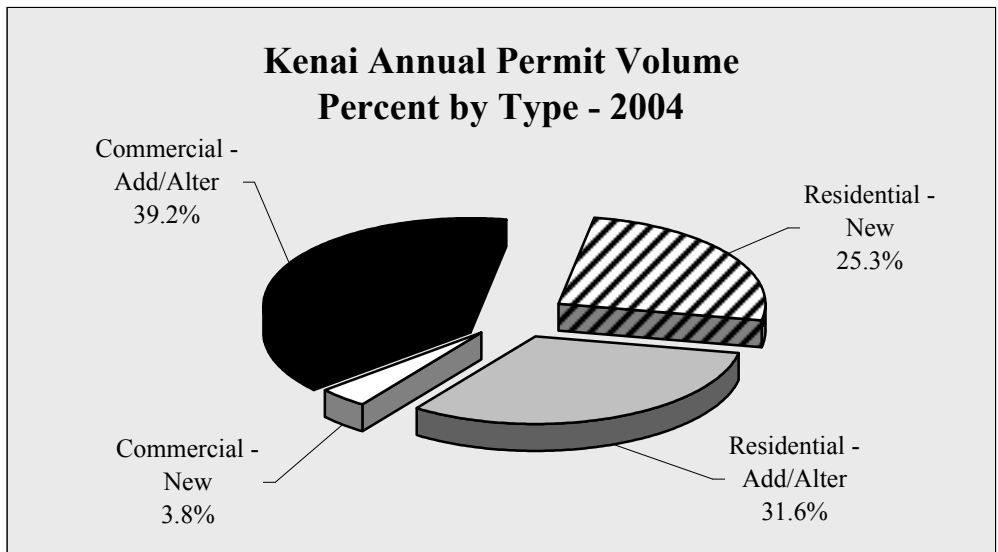

Chart 3.16

Kenai Construction Permitting

Kenai Permit Values by Quarter by Type - 1998-2005 - in \$

	1st Quarter	2nd Quarter	3rd Quarter	4th Quarter	Total
1998					
Residential - New	208,500	3,884,500	1,524,500	416,000	6,033,500
Residential - Add/Alter	68,500	495,500	122,900	43,800	730,700
Commercial - New	7,000	0	95,000	49,000	151,000
Commercial - Add/Alter	186,500	21,500	432,500	86,500	727,000
TOTAL	470,500	4,401,500	2,174,900	595,300	7,642,200
1999					
Residential - New	0	1,573,000	1,049,000	702,000	3,324,000
Residential - Add/Alter	122,000	187,600	267,000	221,400	798,000
Commercial - New	14,500	61,000	4,597,250	125,000	4,797,750
Commercial - Add/Alter	103,000	201,000	209,400	8,600	522,000
TOTAL	239,500	2,022,600	6,122,650	1,057,000	9,441,750
2000					
Residential - New	228,000	1,606,000	1,287,000	376,000	3,497,000
Residential - Add/Alter	7,000	439,000	387,000	55,400	888,400
Commercial - New	65,000	1,045,000	2,896,000	244,000	4,250,000
Commercial - Add/Alter	162,900	73,000	524,000	2,800	762,700
TOTAL	462,900	3,163,000	5,094,000	678,200	9,398,100
2001					
Residential - New	623,000	2,886,000	1,152,000	324,000	4,985,000
Residential Add/Alter	161,500	228,300	217,500	67,800	675,100
Commercial - New	15,000	3,744,000	1,406,700	214,000	5,379,700
Commercial - Add/Alter	20,000	739,600	1,730,000	49,500	2,539,100
TOTAL	819,500	7,597,900	4,506,200	655,300	13,578,900
2002					
Residential - New	279,000	2,362,000	2,899,000	377,000	5,917,000
Residential Add/Alter	28,000	323,100	302,400	70,000	723,500
Commercial - New	3,579,200	1,480,000	212,000	990,000	6,261,200
Commercial - Add/Alter	2,000	404,300	3,400,600	90,800	3,897,700
TOTAL	3,888,200	4,569,400	6,814,000	1,527,800	16,799,400
2003					
Residential - New	0	1,943,000	560,000	779,000	3,282,000
Residential Add/Alter	15,000	515,200	168,850	183,000	882,050
Commercial - New	0	0	51,000	253,000	304,000
Commercial - Add/Alter	1,542,600	270,150	2,920,500	1,240,500	5,973,750
TOTAL	1,557,600	2,728,350	3,700,350	2,455,500	10,441,800
2004					
Residential - New	300,000	1,079,000	1,197,500	482,000	3,058,500
Residential Add/Alter	12,000	52,200	308,950	27,000	400,150
Commercial - New	0	81,000	250,000	0	331,000
Commercial - Add/Alter	0	685,200	235,300	76,400	996,900
TOTAL	312,000	1,897,400	1,991,750	585,400	4,786,550
2005					
					Year to Date
Residential - New	0				0
Residential Add/Alter	134,500				134,500
Commercial - New	0				0
Commercial - Add/Alter	291,000				291,000
TOTAL	425,500				425,500

Table 3.11

Kenai Construction Permitting

Kenai Permit Volume by Quarter by Type - 1998-2005

	1st Quarter	2nd Quarter	3rd Quarter	4th Quarter	Total
1998					
Residential - New	2	27	13	3	45
Residential - Add/Alter	5	10	13	5	33
Commercial - New	1	0	1	2	4
Commercial - Add/Alter	2	2	3	8	15
TOTAL	10	39	30	18	97
1999					
Residential - New	0	12	7	7	26
Residential - Add/Alter	3	13	12	13	41
Commercial - New	1	1	10	1	13
Commercial - Add/Alter	3	7	11	1	22
TOTAL	7	33	40	22	102
2000					
Residential - New	1	11	11	3	26
Residential - Add/Alter	2	18	18	7	45
Commercial - New	1	4	4	2	11
Commercial - Add/Alter	4	3	3	1	11
TOTAL	8	36	36	13	93
2001					
Residential - New	4	16	8	2	30
Residential Add/Alter	5	13	8	5	31
Commercial - New	1	3	3	1	8
Commercial - Add/Alter	1	10	4	3	18
TOTAL	11	42	23	11	87
2002					
Residential - New	2	18	19	3	42
Residential Add/Alter	1	14	26	4	45
Commercial - New	1	3	2	3	9
Commercial - Add/Alter	1	2	12	10	25
TOTAL	5	37	59	20	121
2003					
Residential - New	0	13	3	6	22
Residential Add/Alter	1	16	22	5	44
Commercial - New	0	0	2	2	4
Commercial - Add/Alter	7	11	18	8	44
TOTAL	8	40	45	21	114
2004					
Residential - New	3	5	8	4	20
Residential Add/Alter	1	8	12	4	25
Commercial - New	0	2	1	0	3
Commercial - Add/Alter	0	15	10	6	31
TOTAL	4	30	31	14	79
2005 Year to Date					
Residential - New	0				0
Residential Add/Alter	7				7
Commercial - New	0				0
Commercial - Add/Alter	3				3
TOTAL	10	0	0	0	10

Table 3.12

Kenai Cost of Food Survey

Cost of food data is collected by the University of Alaska, Fairbanks Cooperative Extension. Each quarter the Cooperative Extension surveys up to three grocers in communities throughout the state to determine the cost of food for one week. Specific guidelines are presented to the surveyors regarding item size and sale price for 104 items. It has been determined that separation of Kenai and Soldotna data would be meaningless so data presented relates to both communities.

KENAI/SOLDOTNA										
	March 1997	March 1998	March 1999	March 2000	March 2001	March 2002	March 2003	March 2004	March 2005	Annual Change
Sales Tax (in percent)	5.0	5.0	5.0	5.0	5.0	5.0	5.0	5.0	5.0	
Percent of Food Unavailable	0.0	0.0	0.0	1.0	1.0	0.0	1.0	0.0	0.0	
Child, 1 year	16.4	15.9	16.6	16.7	16.8	17.1	18.1	19.2	19.1	-0.6%
Child, 2 years	0.0	0.0	0.0	0.0	0.0	17.1	18.1	18.9	18.9	-0.2%
Children 3-5 years of age	22.2	17.4	18.2	14.7	18.4	18.7	19.9	20.8	20.8	0.4%
Children 6-8 years of age	23.8	23.0	24.2	18.1	24.5	25.0	26.6	28.0	27.9	-0.3%
Children 9-11 years of age	27.0	26.2	27.5	27.5	27.8	28.3	30.1	31.5	31.4	-0.2%
Males 12-14 years of age	30.6	29.5	31.0	31.1	31.5	32.0	33.9	35.4	35.5	0.2%
Males 15-19 years of age	31.5	30.4	31.9	32.0	32.5	33.0	34.9	36.5	36.6	0.2%
Males 20-50 years of age	31.3	30.2	31.6	31.8	32.4	33.0	35.0	36.6	36.7	0.2%
Males 51 and older	29.9	28.9	30.1	30.3	30.8	31.5	33.3	34.9	35.0	0.1%
Females 12-19 years of age	26.4	25.5	26.7	26.8	27.2	27.6	29.2	30.7	30.7	0.2%
Females 20-50 years of age	27.5	26.6	27.6	27.8	28.4	28.9	30.6	32.0	32.0	-0.1%
Females 51 and older	26.7	25.7	26.8	27.0	27.6	28.1	29.7	31.0	31.1	0.2%
Family of 2, 20-50 years of age	62.7	62.5	65.1	65.5	66.8	68.1	72.2	75.4	75.5	0.1%
Family of 2, 51 years and older	62.2	60.1	62.6	63.0	64.2	65.5	69.4	72.5	72.6	0.2%
Family of 4, children 1-5 years	93.1	90.0	94.0	94.5	96.0	97.7	103.6	108.2	108.3	0.1%
Family of 4, children 6-11 years	109.6	105.9	110.9	111.4	113.1	115.2	122.2	128.1	127.9	-0.1%
Electricity, 1000 kWh	111.0	119.9	120.7	119.4	111.9	122.1	124.4	100.8	115.4	14.4%
Gasoline, auto, 55 gal	77.0	74.8	67.3	82.0	94.1	79.5	100.1	100.7	120.5	19.7%
Lumber, 2X4X8'	3.9	3.3	3.5	3.6	3.0	3.1	3.3	3.0	3.3	8.2%
Propane, 100 lb. refill	39.5	39.5	34.9	42.5	49.6	43.4	54.0	49.1	56.6	15.4%
Sewer & Water, monthly	41.6	41.3	0.0	0.0	0.0	0.0	0.0	0.0	0.0	NA

Table 3.13

Kenai Cost of Food Survey

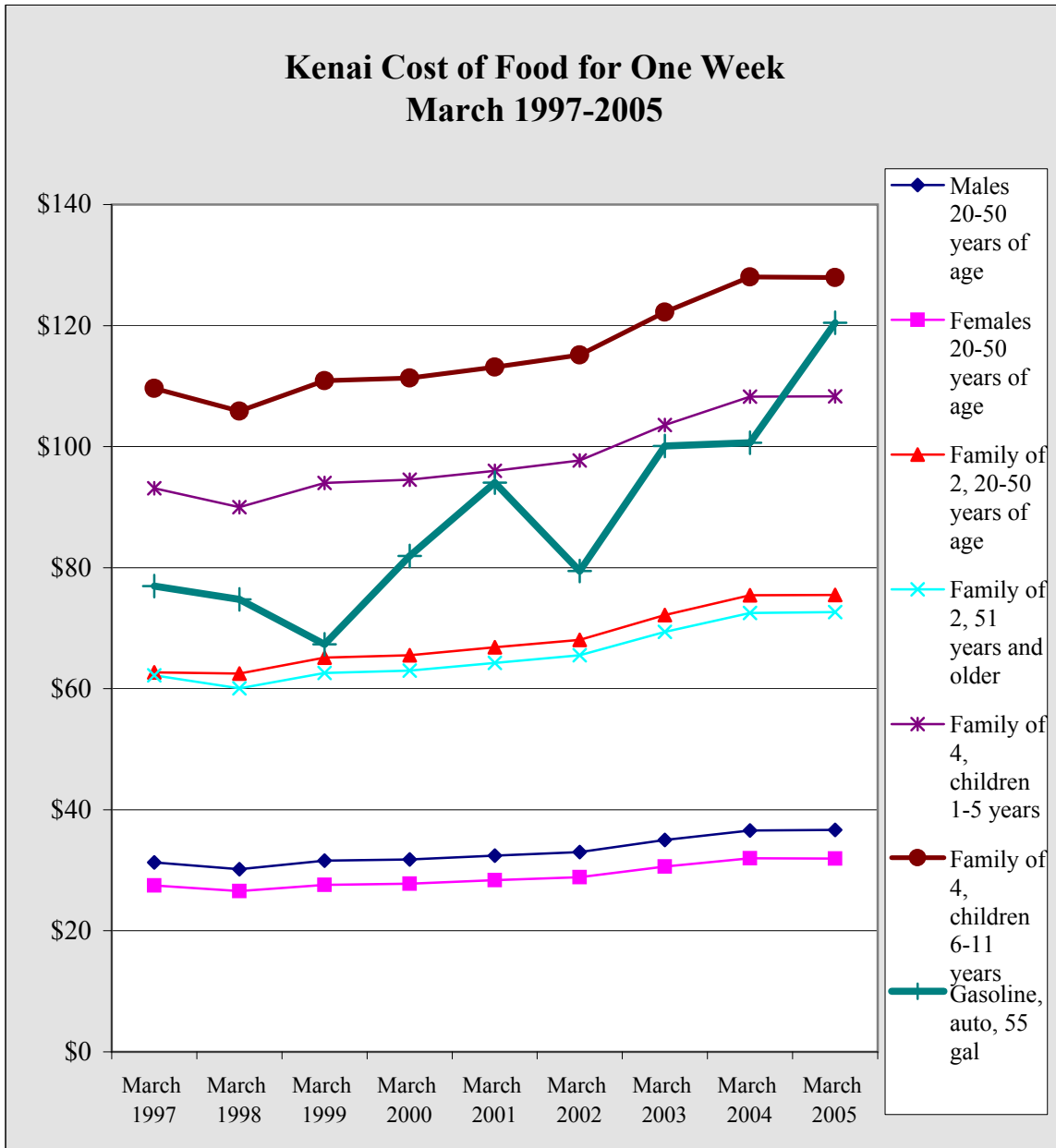

Chart 3.17

Kenai Population

Kenai Select Detail - 1990 & 2000

Population					Housing				
	1990	2000	Percent Change	Percent of Total		1990	2000	Percent Change	Percent of Total
Total Population	6,327	6,942	9.7%	100.0%	Total Households	2,329	2,622	12.6%	100.0%
Male	3,269	3,430	4.9%	49.4%	Family Households	1,626	1,787	9.9%	68.2%
Female	3,058	3,512	14.8%	50.6%	With Children Under 18		1,066	NA	40.7%
Under 5 years	673	554	-17.7%	8.0%	Married Couple Family	1,294	1,325	2.4%	50.5%
5 to 9 years	615	635	3.3%	9.1%	With Own Children Under 18		703	NA	26.8%
10 to 14 years	471	689	46.3%	9.9%	Female Householder, no husband present		320	NA	12.2%
15 to 19 years	493	577	17.0%	8.3%	With Own Children Under 18		261	NA	10.0%
20 to 24 years	443	356	-19.6%	5.1%	Average Household Size	2.70	2.64	NA	0.1%
25 to 34 years	1,303	899	-31.0%	13.0%	Average Family Size		3.20	NA	0.1%
35 to 44 years	1,065	1,274	19.6%	18.4%	Total Housing Units	2,681	3,003	NA	114.5%
45 to 54 years	624	994	59.3%	14.3%	Occupied Housing Units	2,329	2,622	12.6%	100.0%
55 to 59 years	206	317	53.9%	4.6%	Vacant Housing Units	352	381	8.2%	14.5%
60 to 64 years	175	204	16.6%	2.9%	Seasonal, Recreational, Occasional Use	50	58	16.0%	2.2%
65 to 74 years	207	281	35.7%	4.0%	Owner Vacancy Rate	6.3%	2.6%	NA	NA
75 to 84 years	41	137	234.1%	2.0%	Rental Vacancy Rate	8.7%	17.9%	NA	NA
85 years and over	11	25	127.3%	0.4%	Owner Occupied Units	1,270	1,583	24.6%	60.4%
Median Age	28.6	32.3	12.9%	NA	Renter Occupied Units	1,059	1,039	-1.9%	39.6%
18 Years and Over	2,074	4,665	124.9%	NA	Marital Status (over 15)		5,099	NA	NA
Male		2,292	NA	NA	Never married		1,199	NA	23.5%
Female		2,373	NA	NA	Married except separated		2,845	NA	55.8%
65 Years and Over	259	443	71.0%	NA	Separated		106	NA	2.1%
Male		195	NA	NA	Widowed		200	NA	3.9%
Female		248	NA	NA	Divorced		749	NA	14.7%
Place of Birth					Disabled, Noninstitutionalized				
Native Born	6,176	6,777	9.7%	97.6%	Population 5 to 20		1,896	NA	100.0%
Born in Alaska		2,458	NA	35.4%	With a Disability		149	NA	7.9%
Born in other state		4,255	NA	61.3%	Population 21 to 64		3,997	NA	100.0%
Foreign Born	151	159	5.3%	2.3%	With a Disability		297	NA	7.4%
Naturalized Citizen		69	NA	1.0%	Percent Employed		39.5%	NA	0.0%
Not a Citizen		90	NA	1.3%	Without a Disability		3,400	NA	85.1%
Veteran Status					Percent Employed		71.0%	NA	0.0%
Civilian veterans	815	784	NA	16.7%	Income in 1999 - Families				
Educational Attainment					Total	1,773			
Population 25 years and over				4,212	Less than \$10,000	95	85	-10.5%	4.8%
Less than 9th grade	118	141	19.5%	3.3%	\$10,000 - \$14,999	78	68	-12.8%	3.8%
9th-12th, no diploma	340	350	2.9%	8.3%	\$15,000 - \$24,999	165	182	10.3%	10.3%
High School Diploma	1,347	1,372	1.9%	32.6%	\$25,000 - \$34,999	198	233	17.7%	13.1%
College, no degree	1,050	1,417	35.0%	33.6%	\$35,000 - \$49,999	293	209	-28.7%	11.8%
Associate Degree	241	256	6.2%	6.1%	\$50,000 - \$74,999	438	436	-0.5%	24.6%
Bachelor's Degree	374	469	25.4%	11.1%	\$75,000 - \$99,999	216	310	43.5%	17.5%
Graduate, Profess Degree	178	207	16.3%	4.9%	\$100,000 - \$149,999	108	190	75.9%	10.7%
Percent HS Grad	87.4%	88.3%	1.0%	NA	\$150,000 - \$199,999	48	45	-6.3%	2.5%
Percent Bachelor's +	15.1%	16.0%	6.0%	NA	\$200,000 or more	NA	15	NA	0.8%
					Median Income - \$	49,552	56,856	14.7%	NA

Table 3.14

Seldovia Sales

Seldovia 1st Quarter Gross Sales by Industry - 1999-2005 - in \$								
	1999	2000	2001	2002	2003	2004	2005	Annual Change
Const	12,261	46,844	30,023	66,782	27,947	601,376	433,991	-27.8%
Manu	3,227	3,729	2,989	1,704	1,845	1,249	1,331	6.6%
TCPU	188,073	159,367	162,024	163,245	147,749	151,748	160,989	6.1%
Whole	254,537	16,761	25,686	3,760	9,201	14,150	12,898	-8.8%
Retail	312,303	807,661	553,396	485,479	544,320	522,637	524,567	0.4%
FIRE	38,117	14,063	23,824	158,668	7,090	9,127	16,009	75.4%
Service	99,540	102,267	100,869	132,074	108,853	104,760	85,899	-18.0%
Total	908,058	1,150,692	898,811	1,011,712	847,005	1,405,047	1,235,684	-12.1%
Annual Change		26.7%	-21.9%	12.6%	-16.3%	65.9%	-12.1%	

Table 4.1

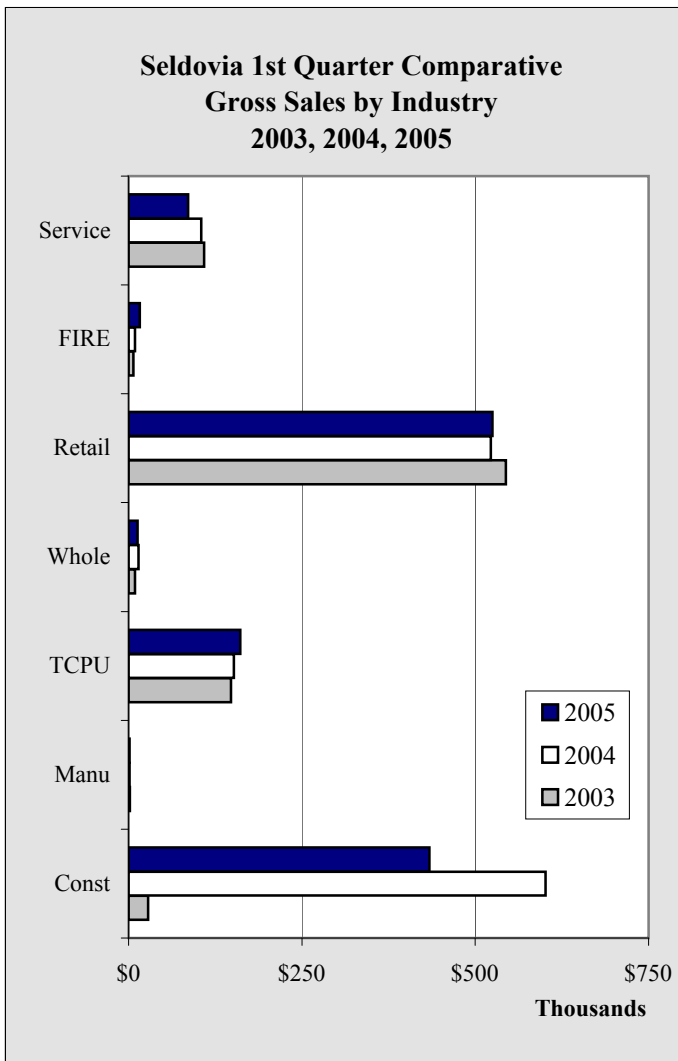

Chart 4.1

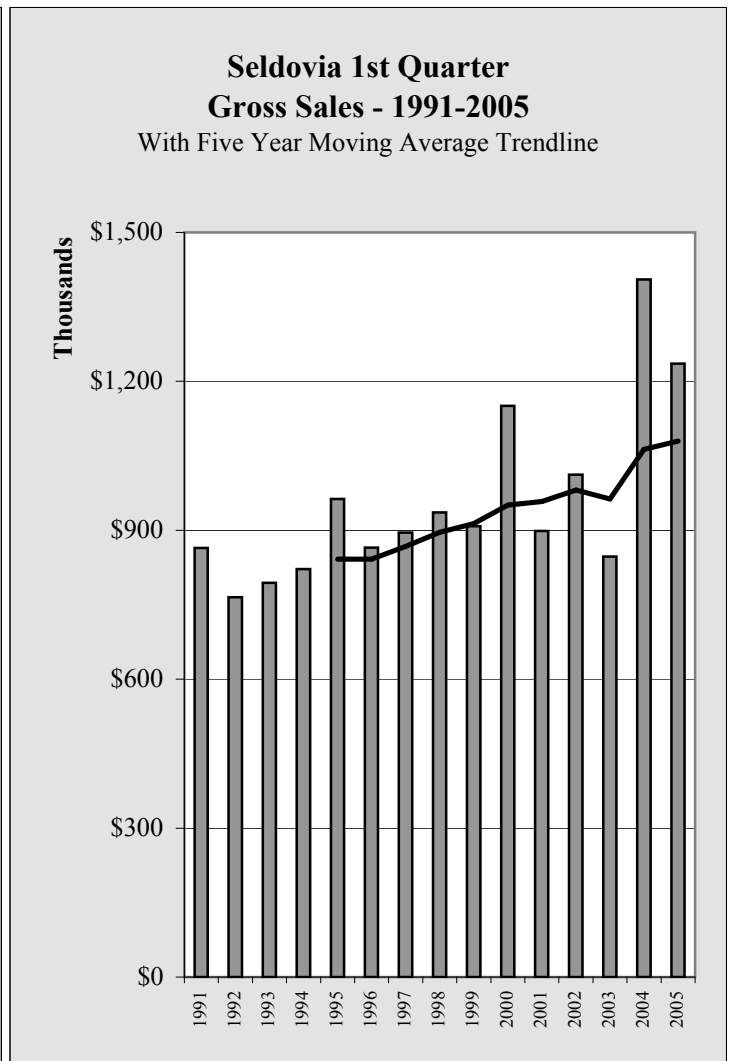

Chart 4.2

Seldovia Sales

Seldovia 1st Quarter Taxable Sales by Industry - 1999-2005 - in \$								
	1999	2000	2001	2002	2003	2004	2005	Annual Change
Const	4,361	9,989	7,595	6,980	1,131	5,160	4,155	-19.5%
Manu	1,078	1,709	1,054	1,194	368	649	831	28.0%
TCPU	113,032	110,305	117,188	115,021	103,692	96,989	102,157	5.3%
Whole	97,835	1,003	250	159	150	30	75	150.0%
Retail	275,795	369,861	392,049	367,416	415,056	392,241	381,255	-2.8%
FIRE	18,037	8,593	6,389	7,178	4,600	5,942	11,204	88.6%
Service	59,300	67,633	59,030	75,676	73,973	65,715	64,083	-2.5%
Total	569,438	569,093	583,555	573,624	598,970	566,726	563,760	-0.5%
Annual Change		-0.1%	2.5%	-1.7%	4.4%	-5.4%	-0.5%	

Table 4.2

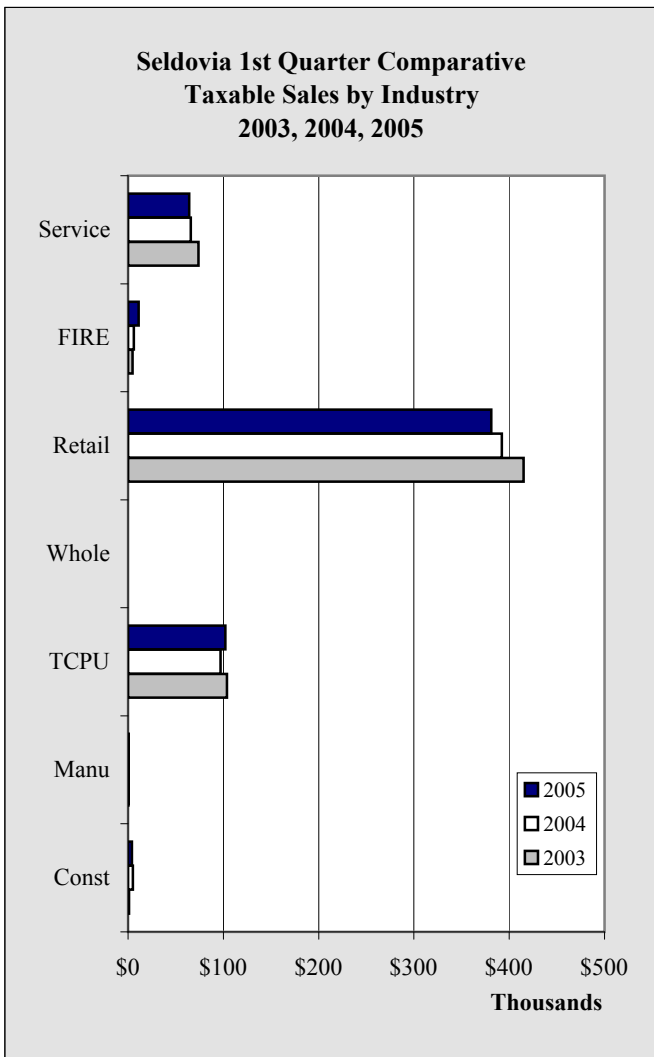

Chart 4.3

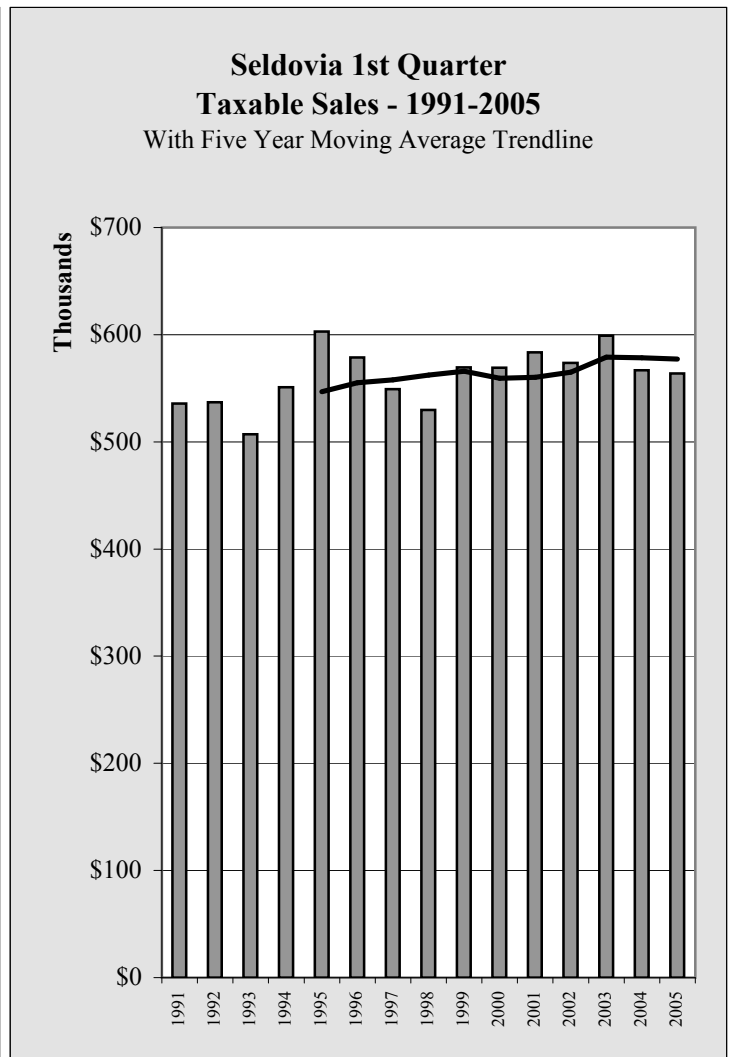

Chart 4.4

Seldovia Sales

Seldovia Annual Gross Sales by Industry - 1998-2004 - in \$

	1998	1999	2000	2001	2002	2003	2004	Annual Change
AFF	3,422	3,084	2,797	3,787	6,306	5,737	28,760	401.3%
Const	302,999	200,475	567,881	427,249	233,790	2,235,069	2,432,152	8.8%
Manu	53,202	142,303	22,483	40,983	41,694	44,136	24,563	-44.3%
TCPU	724,009	702,895	642,067	615,305	589,101	609,377	621,624	2.0%
Whole	886,557	466,249	74,511	58,140	40,755	143,974	105,348	-26.8%
Retail	1,698,659	2,359,533	2,969,768	2,710,711	2,527,071	2,565,299	2,640,802	2.9%
FIRE	134,421	111,959	62,750	509,244	443,797	590,854	1,446,162	144.8%
Service	920,470	858,272	925,068	884,052	935,363	1,065,108	1,025,790	-3.7%
Total	4,723,739	4,844,770	5,267,325	5,249,471	4,817,877	7,259,554	8,325,201	14.7%
Annual Change		2.6%	8.7%	-0.3%	-8.2%	50.7%	14.7%	

Table 4.3

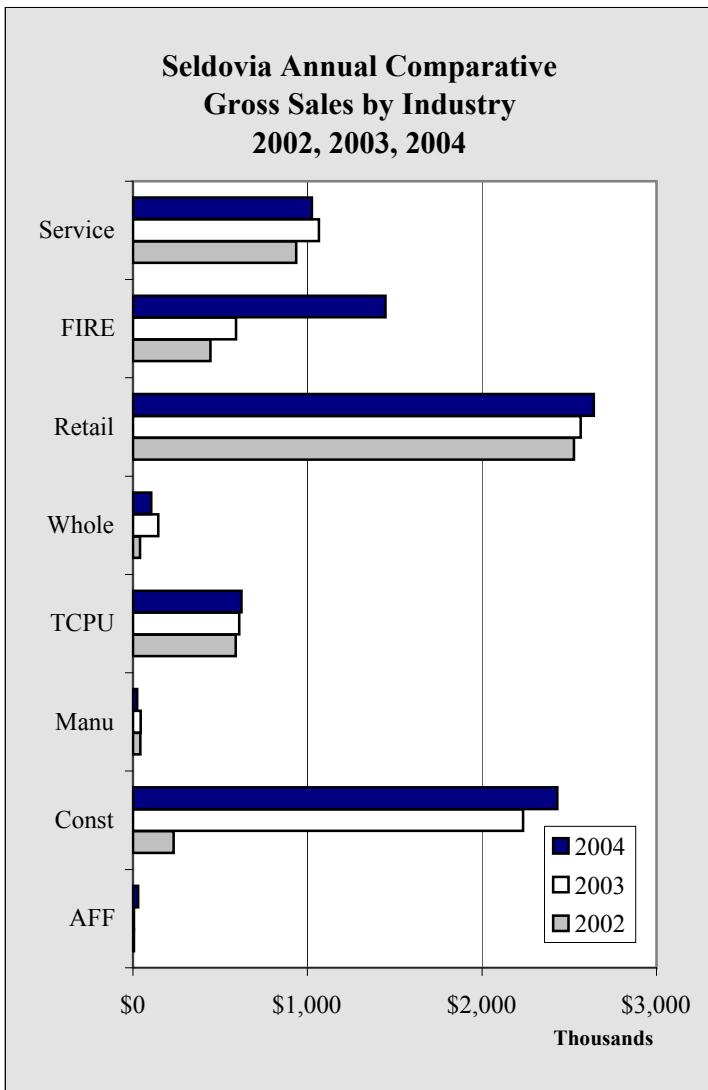

Chart 4.5

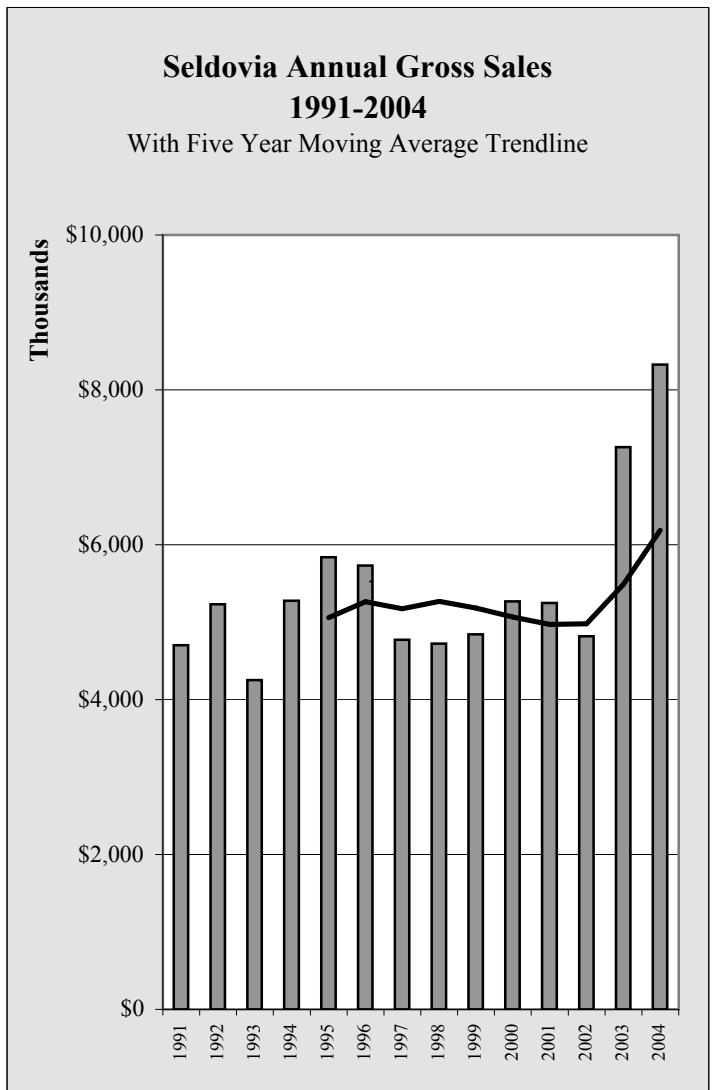

Chart 4.6

Seldovia Sales

Seldovia Annual Taxable Sales by Industry - 1998-2004 - in \$

	1998	1999	2000	2001	2002	2003	2004	Annual Change
AFF	3,422	3,084	2,771	3,616	3,551	2,970	3,140	5.7%
Const	32,244	37,757	41,098	34,175	22,683	26,848	27,088	0.9%
Manu	16,711	7,035	4,892	4,818	6,509	9,098	9,146	0.5%
TCPU	438,292	473,005	455,499	410,584	427,667	450,291	411,317	-8.7%
Whole	510,369	106,422	4,692	4,069	945	1,649	426	-74.2%
Retail	1,577,816	1,877,036	2,165,560	2,226,879	2,118,927	2,155,556	2,167,989	0.6%
FIRE	83,118	65,347	28,771	31,657	24,937	29,796	43,310	45.4%
Service	736,321	659,563	714,840	643,481	667,170	700,736	719,266	2.6%
Total	3,398,293	3,229,249	3,418,123	3,359,279	3,272,389	3,376,944	3,381,682	0.1%
Annual Change		-5.0%	5.8%	-1.7%	-2.6%	3.2%	0.1%	

Table 4.4

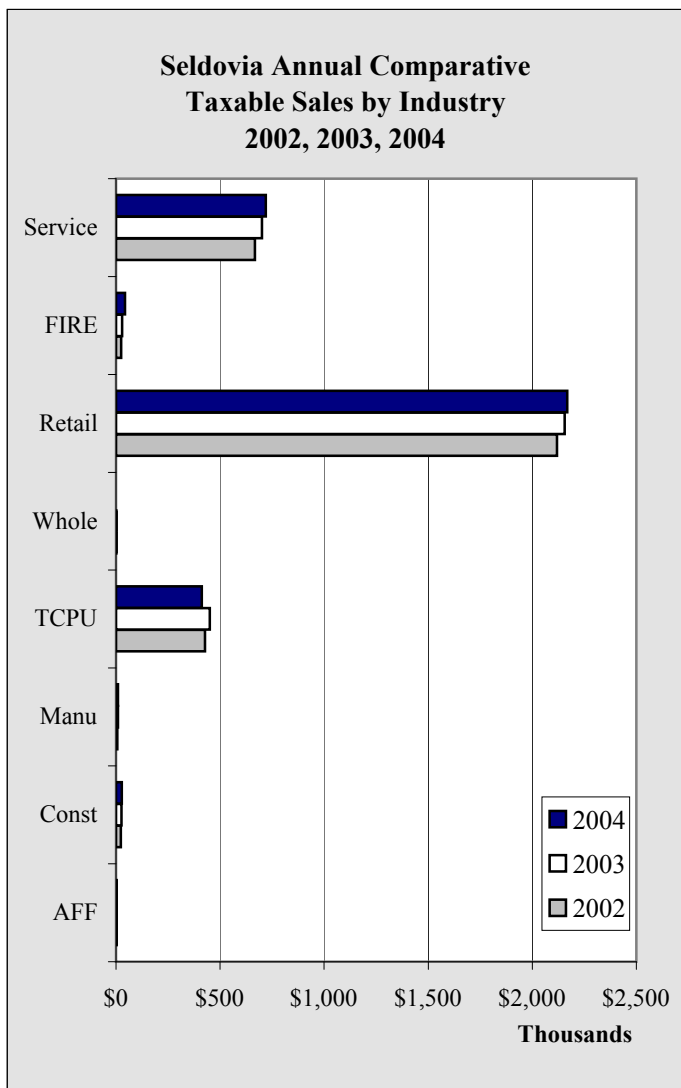

Chart 4.7

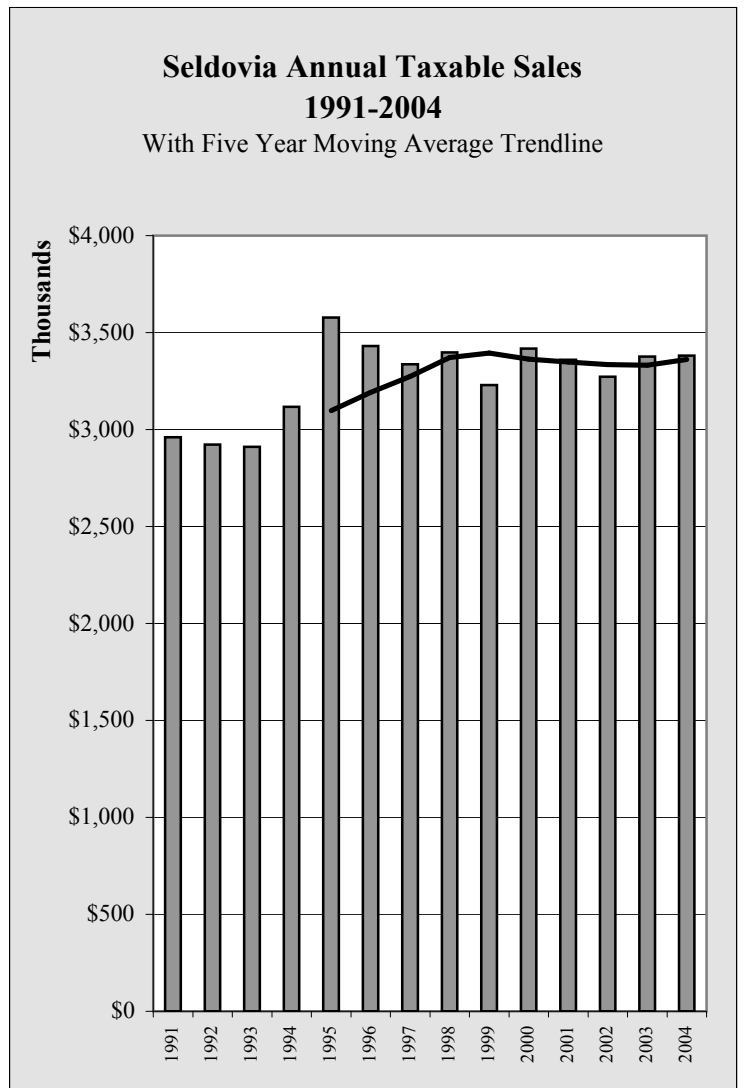

Chart 4.8

Seldovia Sales

Seldovia Gross Sales by Industry by Quarter - 2001-2005 - in \$					
	1st Quarter	2nd Quarter	3rd Quarter	4th Quarter	Total
2001					
AFF	0	3,707	80	0	3,787
Const	30,023	287,028	65,667	44,531	427,249
Manu	2,989	14,430	22,581	983	40,983
TCPU	162,024	138,629	167,386	147,266	615,305
Whole	25,686	13,490	12,723	6,241	58,140
Retail	553,396	758,967	835,067	563,281	2,710,711
FIRE	23,824	17,006	458,280	10,134	509,244
Service	100,869	240,048	395,770	147,365	884,052
Total	898,811	1,473,305	1,957,554	919,801	5,249,471
2002					
AFF	0	6,306	0	0	6,306
Const	66,782	42,719	84,321	39,968	233,790
Manu	1,704	5,911	2,556	31,523	41,694
TCPU	163,245	136,379	137,154	152,323	589,101
Whole	3,760	7,040	22,402	7,553	40,755
Retail	485,479	690,215	825,256	526,121	2,527,071
FIRE	158,668	8,734	220,225	56,170	443,797
Service	132,074	257,751	402,260	143,278	935,363
Total	1,011,712	1,155,055	1,694,174	956,936	4,817,877
2003					
AFF	0	5,737	0	0	5,737
Const	27,947	213,775	1,256,705	736,642	2,235,069
Manu	1,845	25,326	14,320	2,645	44,136
TCPU	147,749	135,580	137,236	188,812	609,377
Whole	9,201	17,477	71,441	45,855	143,974
Retail	544,320	711,358	768,860	540,761	2,565,299
FIRE	7,090	242,188	91,073	250,503	590,854
Service	108,853	278,014	494,150	184,091	1,065,108
Total	847,005	1,629,455	2,833,785	1,949,309	7,259,554
2004					
AFF	0	11,260	17,500	0	28,760
Const	601,376	763,635	360,893	706,248	2,432,152
Manu	1,249	8,735	12,786	1,793	24,563
TCPU	151,748	152,078	168,520	149,278	621,624
Whole	14,150	26,237	30,407	34,554	105,348
Retail	522,637	722,686	762,079	633,400	2,640,802
FIRE	9,127	10,170	14,447	1,412,418	1,446,162
Service	104,760	276,869	442,435	201,726	1,025,790
Total	1,405,047	1,971,670	1,809,067	3,139,417	8,325,201
2005					
					Year to Date
AFF	0				0
Const	0				0
Manu	433,991				433,991
TCPU	1,331				1,331
Whole	160,989				160,989
Retail	12,898				12,898
FIRE	524,567				524,567
Service	16,009				16,009
Total	1,149,785				1,149,785

Table 4.5

Seldovia Sales

Seldovia Taxable Sales by Industry by Quarter - 2001-2005 - in \$					
	1st Quarter	2nd Quarter	3rd Quarter	4th Quarter	Total
2001					
AFF	0	3,616	0	0	3,616
Const	7,595	9,498	9,793	7,289	34,175
Manu	1,054	1,243	2,047	474	4,818
TCPU	117,188	94,825	105,304	93,267	410,584
Whole	250	1,305	1,416	1,098	4,069
Retail	392,049	657,146	751,665	426,019	2,226,879
FIRE	6,389	7,434	10,190	7,644	31,657
Service	59,030	180,966	327,110	76,375	643,481
Total	583,555	956,033	1,207,525	612,166	3,359,279
2002					
AFF	0	3,551	0	0	3,551
Const	6,980	9,130	5,551	1,022	22,683
Manu	1,194	1,806	655	2,854	6,509
TCPU	115,021	95,299	106,236	111,111	427,667
Whole	159	135	651	0	945
Retail	367,416	590,349	754,759	406,403	2,118,927
FIRE	7,178	6,144	7,535	4,080	24,937
Service	75,676	192,416	316,602	82,476	667,170
Total	573,624	898,830	1,191,989	607,946	3,272,389
2003					
AFF	0	2,970	0	0	2,970
Const	1,131	9,946	6,900	8,871	26,848
Manu	368	1,749	6,036	945	9,098
TCPU	103,692	96,701	107,036	142,862	450,291
Whole	150	321	640	538	1,649
Retail	415,056	620,851	693,503	426,146	2,155,556
FIRE	4,600	9,430	7,783	7,983	29,796
Service	73,973	220,998	318,421	87,344	700,736
Total	598,970	962,966	1,140,319	674,689	3,376,944
2004					
AFF	0	3,140	0	0	3,140
Const	5,160	8,058	7,520	6,350	27,088
Manu	649	2,135	4,964	1,398	9,146
TCPU	96,989	105,084	118,010	91,234	411,317
Whole	30	137	131	128	426
Retail	392,241	613,360	698,936	463,452	2,167,989
FIRE	5,942	8,540	10,589	18,239	43,310
Service	65,715	199,135	341,988	112,428	719,266
Total	566,726	939,589	1,182,138	693,229	3,381,682
2005					
	Year to Date				
AFF	0				0
Const	0				0
Manu	4,155				4,155
TCPU	831				831
Whole	102,157				102,157
Retail	75				75
FIRE	381,255				381,255
Service	11,204				11,204
Total	499,677				499,677

Table 4.6

Seldovia 1st Quarter Permit Values by Type - 1999-2005 - in \$							
	1999	2000	2001	2002	2003	2004	2005
Residential - New	0	18,000	0	0	0	20,000	0
Residential - Add/Alter	0	6,000	0	10,000	31,000	0	15,000
Commercial - New	8,000	0	0	0	0	0	0
Commercial - Add/Alter	0	0	10,000	0	0	0	0
TOTAL	8,000	24,000	10,000	10,000	31,000	20,000	15,000
Annual Change		200.0%	-58.3%	0.0%	210.0%	-35.5%	-25.0%

Table 4.7

Seldovia 1st Quarter Permit Volume by Type - 1999-2005							
	1999	2000	2001	2002	2003	2004	2005
Residential - New	0	2	0	0	0	1	0
Residential - Add/Alter	0	1	0	1	3	0	1
Commercial - New	1	0	0	0	0	0	0
Commercial - Add/Alter	0	0	1	0	0	0	0
TOTAL	1	3	1	1	3	1	1
Annual Change		200.0%	-66.7%	0.0%	200.0%	-66.7%	0.0%

Table 4.8

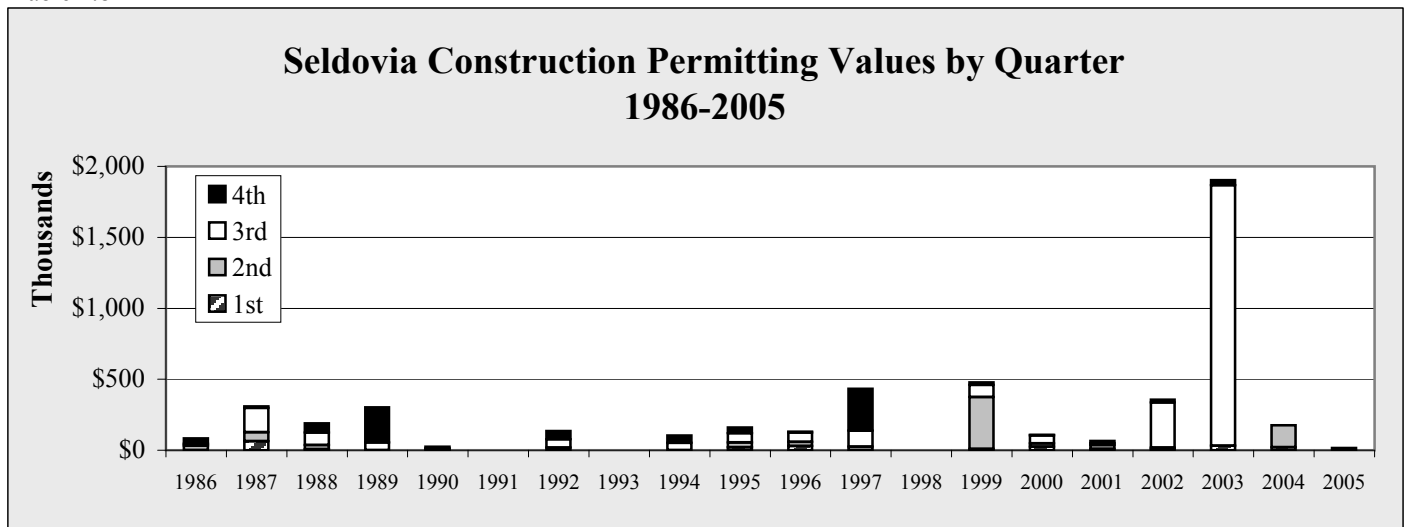

Chart 4.9

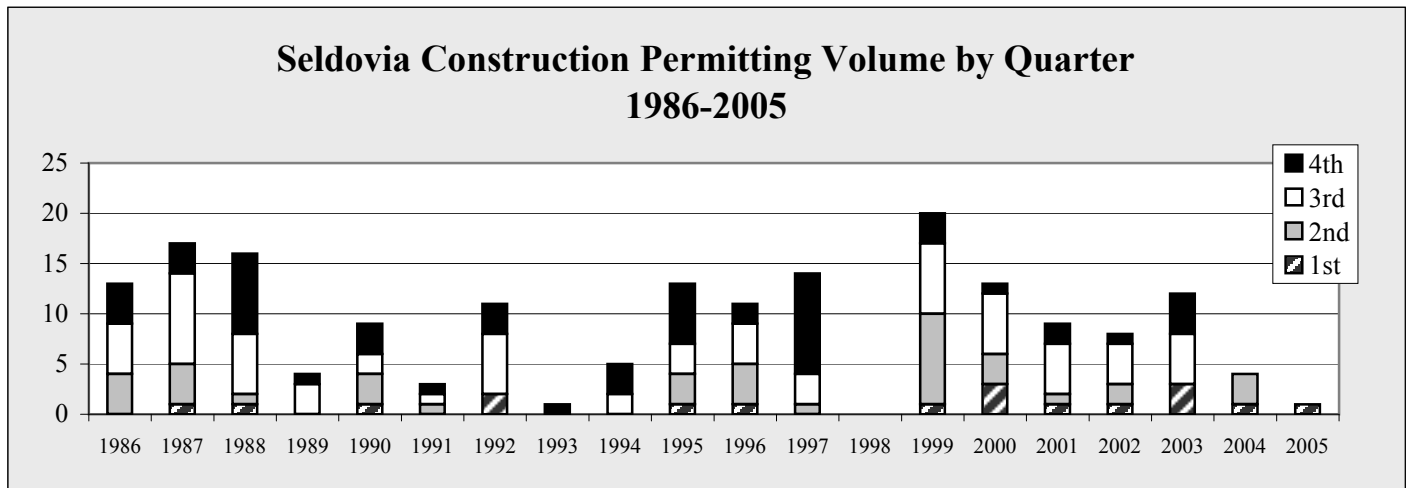

Chart 4.10

Seldovia Construction Permitting

Seldovia Annual Permit Values by Type by Quarter - 1998-2005 - in \$					
	1st Quarter	2nd Quarter	3rd Quarter	4th Quarter	Total
1998					
Residential - New	0	0	0	0	0
Residential - Add/Alter	0	0	0	0	0
Commercial - New	0	0	0	0	0
Commercial - Add/Alter	0	0	0	0	0
TOTAL	0	0	0	0	0
1999					
Residential - New	0	105,000	55,000	0	160,000
Residential - Add/Alter	0	16,500	14,500	5,000	36,000
Commercial - New	8,000	244,000	12,000	0	264,000
Commercial - Add/Alter	0	0	6,000	13,000	19,000
TOTAL	8,000	365,500	87,500	18,000	479,000
2000					
Residential - New	18,000	8,000	19,000	0	45,000
Residential - Add/Alter	6,000	14,300	35,400	5,000	60,700
Commercial - New	0	0	0	0	0
Commercial - Add/Alter	0	0	3,500	0	3,500
TOTAL	24,000	22,300	57,900	5,000	109,200
2001					
Residential - New	0	25,000	10,000	0	35,000
Residential - Add/Alter	0	0	5,525	5,000	10,525
Commercial - New	0	0	0	0	0
Commercial - Add/Alter	10,000	0	0	10,000	20,000
TOTAL	10,000	25,000	15,525	15,000	65,525
2002					
Residential - New	0	0	308,000	0	308,000
Residential - Add/Alter	10,000	8,000	10,500	20,000	48,500
Commercial - New	0	0	0	0	0
Commercial - Add/Alter	0	0	0	0	0
TOTAL	10,000	8,000	318,500	20,000	356,500
2003					
Residential - New	0	0	150,000	26,000	176,000
Residential - Add/Alter	31,000	0	0	3,000	34,000
Commercial - New	0	0	1,685,000	7,500	1,692,500
Commercial - Add/Alter	0	0	0	0	0
TOTAL	31,000	0	1,835,000	36,500	1,902,500
2004					
Residential - New	20,000	150,000	0	0	170,000
Residential - Add/Alter	0	6,200	0	0	6,200
Commercial - New	0	0	0	0	0
Commercial - Add/Alter	0	0	0	0	0
TOTAL	20,000	156,200	0	0	176,200
2005					
					Year to Date
Residential - New	0				0
Residential - Add/Alter	15,000				15,000
Commercial - New	0				0
Commercial - Add/Alter	0				0
TOTAL	15,000				15,000

Table 4.9

Seldovia Construction Permitting

Seldovia Annual Permit Volume by Type by Quarter - 1998-2005					
	1st Quarter	2nd Quarter	3rd Quarter	4th Quarter	Total
1998					
Residential - New	0	0	0	0	0
Residential - Add/Alter	0	0	0	0	0
Commercial - New	0	0	0	0	0
Commercial - Add/Alter	0	0	0	0	0
TOTAL	0	0	0	0	0
1999					
Residential - New	0	2	1	0	3
Residential - Add/Alter	0	4	4	1	9
Commercial - New	1	3	1	0	5
Commercial - Add/Alter	0	0	1	2	3
TOTAL	1	9	7	3	20
2000					
Residential - New	2	2	2	0	6
Residential - Add/Alter	1	1	3	1	6
Commercial - New	0	0	0	0	0
Commercial - Add/Alter	0	0	1	0	1
TOTAL	3	3	6	1	13
2001					
Residential - New	0	1	1	0	2
Residential Add/Alter	0	0	4	1	5
Commercial - New	0	0	0	0	0
Commercial - Add/Alter	1	0	0	1	2
TOTAL	1	1	5	2	9
2002					
Residential - New	0	0	2	0	2
Residential Add/Alter	1	2	2	1	6
Commercial - New	0	0	0	0	0
Commercial - Add/Alter	0	0	0	0	0
TOTAL	1	2	4	1	8
2003					
Residential - New	0	0	1	2	3
Residential Add/Alter	3	0	0	1	4
Commercial - New	0	0	3	1	4
Commercial - Add/Alter	0	0	1	0	1
TOTAL	3	0	5	4	12
2004					
Residential - New	1	1	0	0	2
Residential Add/Alter	0	2	0	0	2
Commercial - New	0	0	0	0	0
Commercial - Add/Alter	0	0	0	0	0
TOTAL	1	3	0	0	4
2005					
	Year to Date				
Residential - New	0				0
Residential Add/Alter	1				1
Commercial - New	0				0
Commercial - Add/Alter	0				0
TOTAL	1				1

Table 4.10

Seldovia Population

Seldovia Select Detail - 1990 v 2000

Population					Housing					
	1990	2000	Percent Change	Percent of Total		1990	2000	Percent Change	Percent of Total	
Total Population	316	286	-9.5%	100.0%	Total Households	129	134	3.9%	100.0%	
Male	167	145	-13.2%	50.7%	Family Households	67	71	6.0%	53.0%	
Female	149	141	-5.4%	49.3%	With Children Under 18		30	NA	22.4%	
Under 5 years	23	15	-34.8%	5.2%	Married Couple Family	54	60	11.1%	44.8%	
5 to 9 years	35	21	-40.0%	7.3%	With Own Children Under 18		22	NA	16.4%	
10 to 14 years	20	20	0.0%	7.0%	Female Householder, no husband present		10	NA	7.5%	
15 to 19 years	23	19	-17.4%	6.6%	With Own Children Under 18		8	NA	6.0%	
20 to 24 years	8	7	-12.5%	2.4%	Average Household Size	2.45	2.13	NA	1.6%	
25 to 34 years	46	17	-63.0%	5.9%	Average Family Size		2.93	NA	2.2%	
35 to 44 years	51	43	-15.7%	15.0%	Total Housing Units	221	232	NA	173.1%	
45 to 54 years	45	50	11.1%	17.5%	Occupied Housing Units	129	134	3.9%	100.0%	
55 to 59 years	15	29	93.3%	10.1%	Vacant Housing Units	92	98	6.5%	73.1%	
60 to 64 years	18	28	55.6%	9.8%	Seasonal, Recreational, Occasional Use	58	81	39.7%	60.4%	
65 to 74 years	14	27	92.9%	9.4%	Owner Vacancy Rate	2.5%	NA	NA	NA	
75 to 84 years	12	7	-41.7%	2.4%	Rental Vacancy Rate	30.1%	24.5%	NA	NA	
85 years and over	6	3	-50.0%	1.0%	Owner Occupied Units	78	94	20.5%	70.1%	
Median Age	35.5	45.3	27.6%	NA	Renter Occupied Units	51	40	-21.6%	29.9%	
18 Years and Over	93	217	133.3%	29.4%	Marital Status (over 15)		235	NA	NA	
Male		114	NA	NA	Never married		48	NA	20.4%	
Female		103	NA	NA	Married except separated		133	NA	56.6%	
65 Years and Over	32	37	15.6%	29.4%	Separated		3	NA	1.3%	
Male		22	NA	NA	Widowed		2	NA	0.9%	
Female		15	NA	NA	Divorced		49	NA	20.9%	
Place of Birth					Disabled, Noninstitutionalized					
Native Born	305	283	-7.2%	NA	Population 5 to 20		68	NA	100.0%	
Born in Alaska		106	NA	NA	With a Disability		8	NA	11.8%	
Born in other state		177	NA	NA	Population 21 to 64		187	NA	100.0%	
Foreign Born	10	8	-20.0%	NA	With a Disability		36	NA	19.3%	
Naturalized Citizen		1	NA	NA	Percent Employed		55.6%	NA	0.3%	
Not a Citizen		7	NA	NA	Without a Disability		151	NA	80.7%	
Veteran Status					Percent Employed		64.2%	NA	0.3%	
Civilian veterans	39	49	NA	21.7%	Income in 1999 - Families					
Educational Attainment									Total	66
Population 25 years and over				2,564	Less than \$10,000	0	NA	NA	NA	
Less than 9th grade	8	10	25.0%	0.4%	\$10,000 - \$14,999	9	5	-44.4%	7.6%	
9th-12th, no diploma	14	19	35.7%	0.7%	\$15,000 - \$24,999	12	5	-58.3%	7.6%	
High School Diploma	64	52	-18.8%	2.0%	\$25,000 - \$34,999	5	6	20.0%	9.1%	
College, no degree	46	82	78.3%	3.2%	\$35,000 - \$49,999	14	12	-14.3%	18.2%	
Associate Degree	6	6	0.0%	0.2%	\$50,000 - \$74,999	18	15	-16.7%	22.7%	
Bachelor's Degree	23	35	52.2%	1.4%	\$75,000 - \$99,999	3	14	366.7%	21.2%	
Graduate, Profess Degree	13	10	-23.1%	0.4%	\$100,000 - \$149,999	4	4	0.0%	6.1%	
Percent HS Grad	87.4%	86.4%	-1.1%	0.0%	\$150,000 - \$199,999	2	5	150.0%	7.6%	
Percent Bachelor's +	20.7%	21.0%	1.4%	0.0%	\$200,000 or more	NA	NA	NA	NA	
					Median Income - \$	45,313	58,000	28.0%	NA	

Table 4.11

Seward Sales

Seward 1st Quarter Gross Sales by Industry - 1999-2005 - in \$

	1999	2000	2001	2002	2003	2004	2005	Annual Change
AFF	42,770	29,612	27,525	20,810	35,450	54,549	30,789	-43.6%
Min	67,649	102,213	63,891	48,952	67,921	24,996	32,647	30.6%
Const	3,859,640	2,142,805	3,865,008	3,040,364	3,401,454	3,306,762	6,127,292	85.3%
Manu	811,226	903,176	2,314,947	1,974,606	1,468,277	892,586	939,970	5.3%
TCPU	2,188,096	1,926,386	2,321,975	2,253,103	2,084,901	2,592,442	2,741,108	5.7%
Whole	1,051,496	378,036	361,455	386,897	385,079	544,648	520,186	-4.5%
Retail	7,450,620	8,152,343	6,972,958	7,932,221	7,796,709	8,616,690	9,025,663	4.7%
FIRE	1,904,649	1,966,455	1,089,430	1,790,625	1,394,159	1,407,043	860,232	-38.9%
Service	5,980,741	3,486,771	3,514,083	5,506,435	4,299,310	3,726,982	3,809,268	2.2%
Govt	0	0	0	0	0	0	0	NA
Total	23,356,887	19,087,797	20,531,272	22,954,013	20,933,260	21,166,698	24,087,155	13.8%
Annual Change		-18.3%	7.6%	11.8%	-8.8%	1.1%	13.8%	

Table 5.1

Seward 1st Quarter Comparative Gross Sales by Industry 2003, 2004, 2005

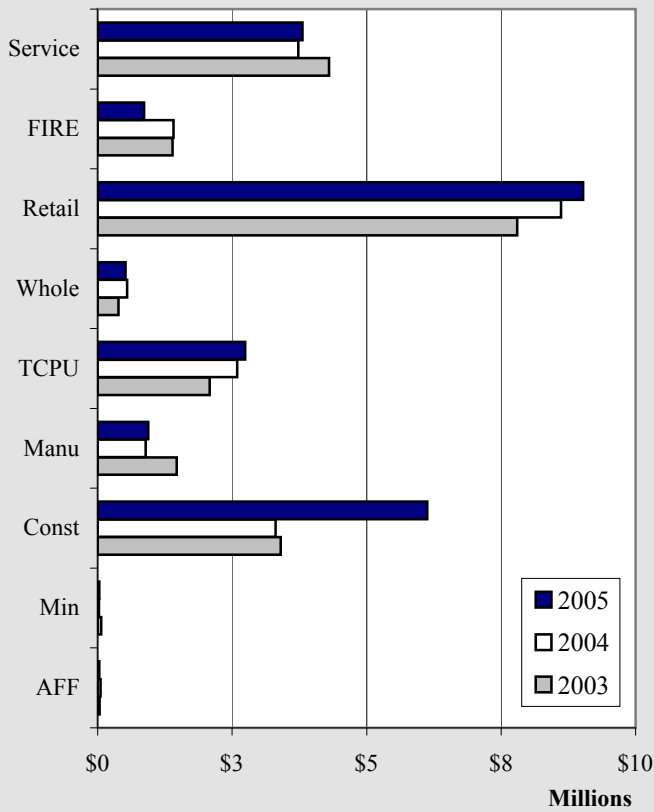

Chart 5.1

Seward 1st Quarter Gross Sales 1991-2005 With Five Year Moving Average Trendline

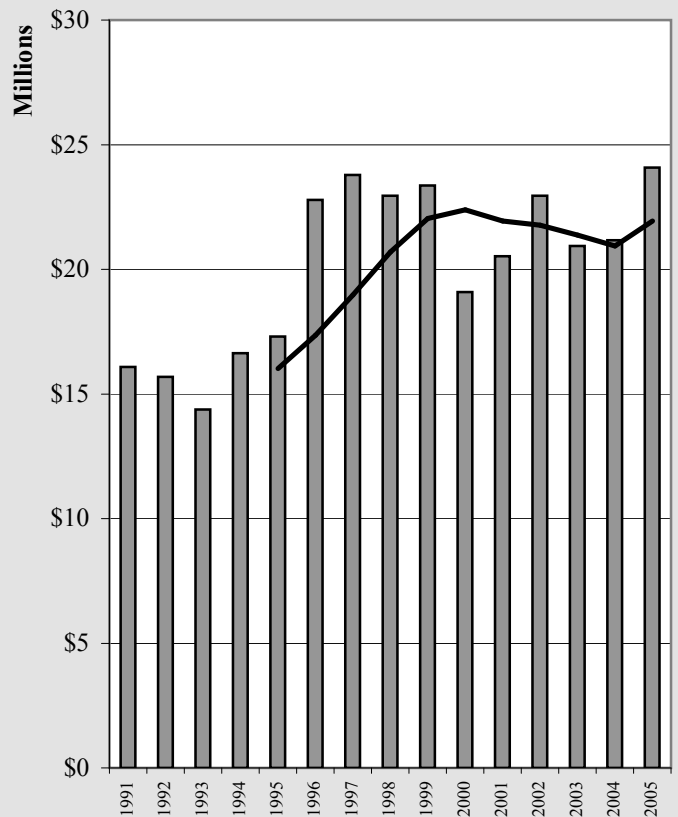

Chart 5.2

Seward Sales

Seward 1st Quarter Taxable Sales by Industry - 1999-2005 - in \$								
	1999	2000	2001	2002	2003	2004	2005	Annual Change
AFF	6,422	11,504	3,990	6,729	11,673	11,923	8,489	-28.8%
Min	1,444	0	0	0	0	0	0	NA
Const	165,176	154,446	130,066	128,807	126,874	167,430	151,989	-9.2%
Manu	152,135	142,706	124,810	115,801	144,853	131,626	79,282	-39.8%
TCPU	699,556	738,521	652,774	560,857	588,465	581,778	583,500	0.3%
Whole	21,666	25,528	29,309	12,026	15,297	23,473	13,977	-40.5%
Retail	5,309,599	5,369,566	5,326,126	5,387,940	5,598,838	5,826,218	6,305,957	8.2%
FIRE	368,278	337,316	363,832	354,630	330,069	295,698	261,416	-11.6%
Service	2,494,402	2,594,773	2,442,586	2,484,254	2,473,272	2,455,335	2,538,939	3.4%
Govt	0	0	0	0	0	0	0	NA
Total	9,218,678	9,374,360	9,073,493	9,051,044	9,289,341	9,493,481	9,943,549	4.7%
Annual Change		1.7%	-3.2%	-0.2%	2.6%	2.2%	4.7%	

Table 5.2

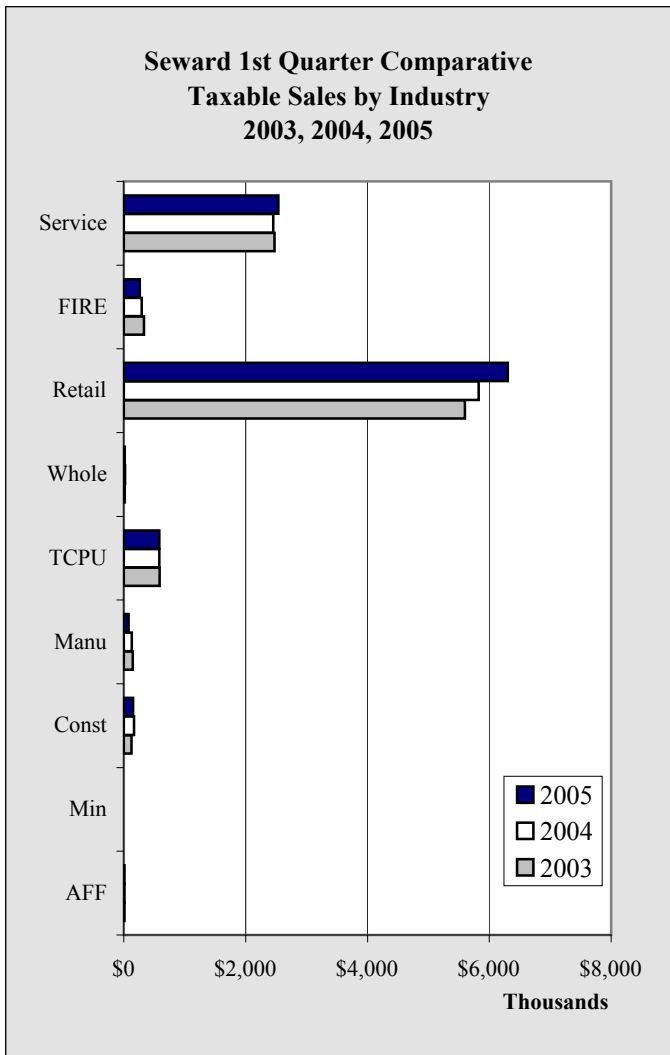

Chart 5.3

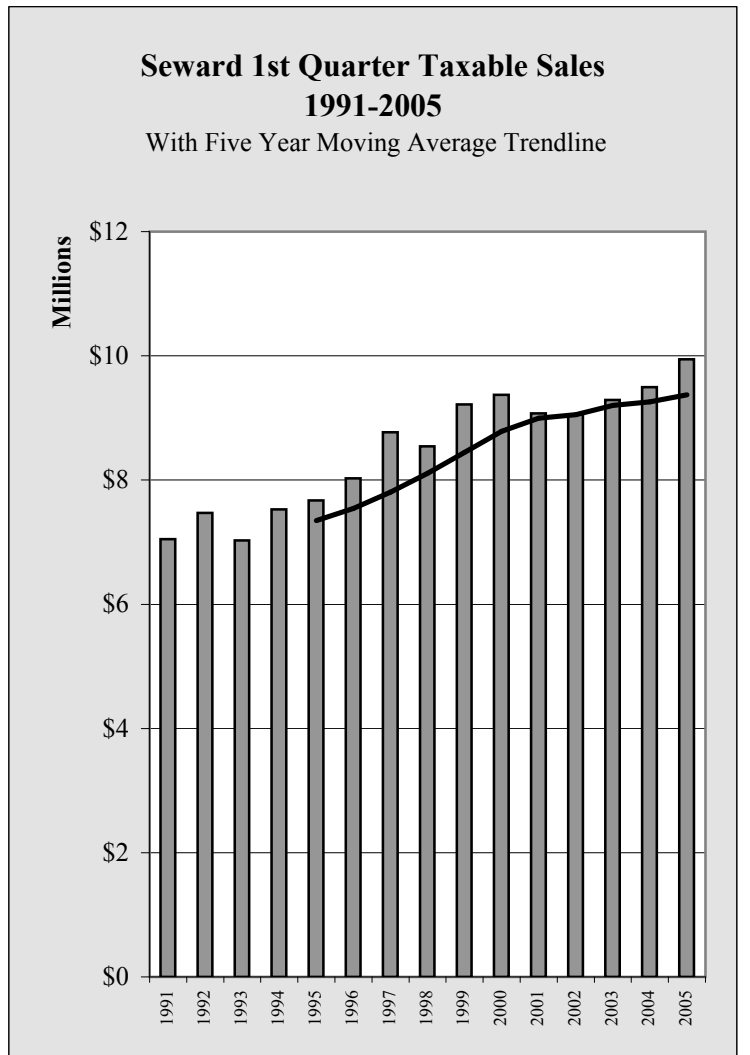

Chart 5.4

Seward Sales

Seward Annual Gross Sales by Industry - 1998-2004 - in \$

	1998	1999	2000	2001	2002	2003	2004	Annual Change
AFF	472,717	414,123	689,481	437,640	298,046	489,097	651,718	33.2%
Min	229,681	332,546	405,115	330,859	377,441	189,755	228,403	20.4%
Const	19,183,104	12,588,992	16,255,816	21,082,426	11,084,304	28,881,212	31,490,526	9.0%
Manu	4,266,551	4,895,971	9,541,307	12,023,577	11,540,635	10,446,881	7,214,583	-30.9%
TCPU	13,656,791	12,011,182	14,705,875	12,840,952	13,026,323	12,969,855	11,702,893	-9.8%
Whole	7,270,151	3,064,525	2,339,175	2,231,731	2,208,659	2,600,579	3,953,585	52.0%
Retail	44,656,247	48,356,132	51,460,505	50,408,318	52,600,754	53,593,021	60,041,140	12.0%
FIRE	8,498,546	9,458,188	8,394,110	6,333,381	7,595,826	7,557,129	7,207,271	-4.6%
Service	34,272,460	39,033,862	38,360,895	42,671,669	43,635,138	40,232,069	43,645,529	8.5%
Govt	0	0	0	0	0	0	0	NA
Total	132,506,248	130,155,521	142,152,279	148,360,553	142,367,126	156,959,598	166,135,648	5.8%
Annual Change		-1.8%	9.2%	4.4%	-4.0%	10.2%	5.8%	

Table 5.3

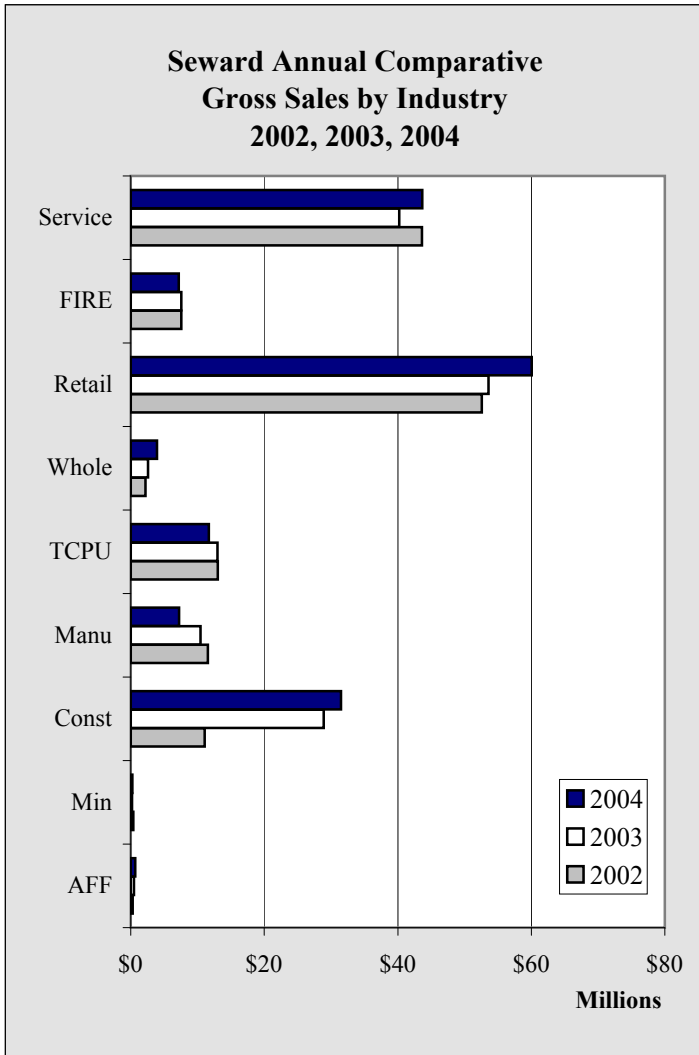

Chart 5.5

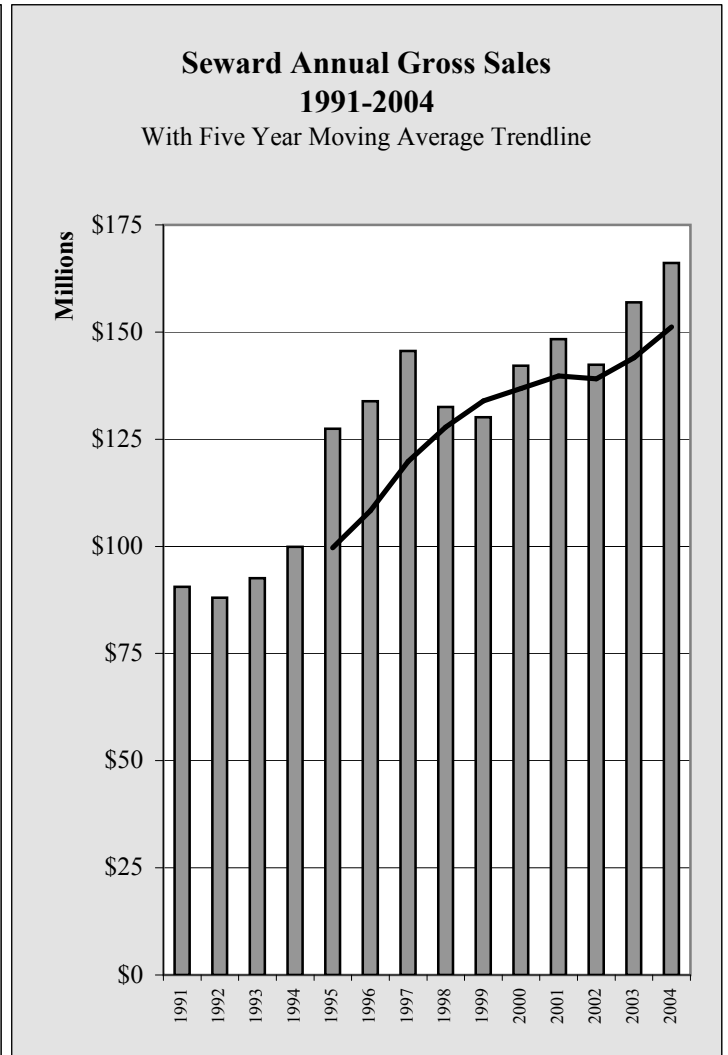

Chart 5.6

Seward Sales

Seward Annual Taxable Sales by Industry - 1998-2004 - in \$								
	1998	1999	2000	2001	2002	2003	2004	Annual Change
AFF	190,979	126,681	240,141	170,624	114,521	217,323	227,337	4.6%
Min	221	1,444	500	0	0	3,455	0	NA
Const	709,318	718,945	671,326	567,626	565,290	683,590	738,180	8.0%
Manu	505,430	585,005	639,366	962,382	988,659	629,648	605,028	-3.9%
TCPU	3,826,559	3,801,591	3,991,338	2,936,725	2,916,215	2,921,669	2,853,456	-2.3%
Whole	382,361	128,287	141,551	135,396	107,027	119,020	107,918	-9.3%
Retail	33,478,522	35,539,902	37,600,377	38,191,615	39,040,960	40,270,165	42,412,476	5.3%
FIRE	1,604,043	1,662,085	1,583,364	1,665,703	1,780,596	1,593,083	1,583,071	-0.6%
Service	26,580,831	28,908,259	29,115,463	29,595,520	30,085,428	29,937,785	31,402,045	4.9%
Govt	0	0	0	0	0	0	0	NA
Total	67,278,264	71,472,199	73,983,426	74,225,591	75,598,696	76,375,738	79,929,511	4.7%
Annual Change		6.2%	3.5%	0.3%	1.8%	1.0%	4.7%	

Table 5.4

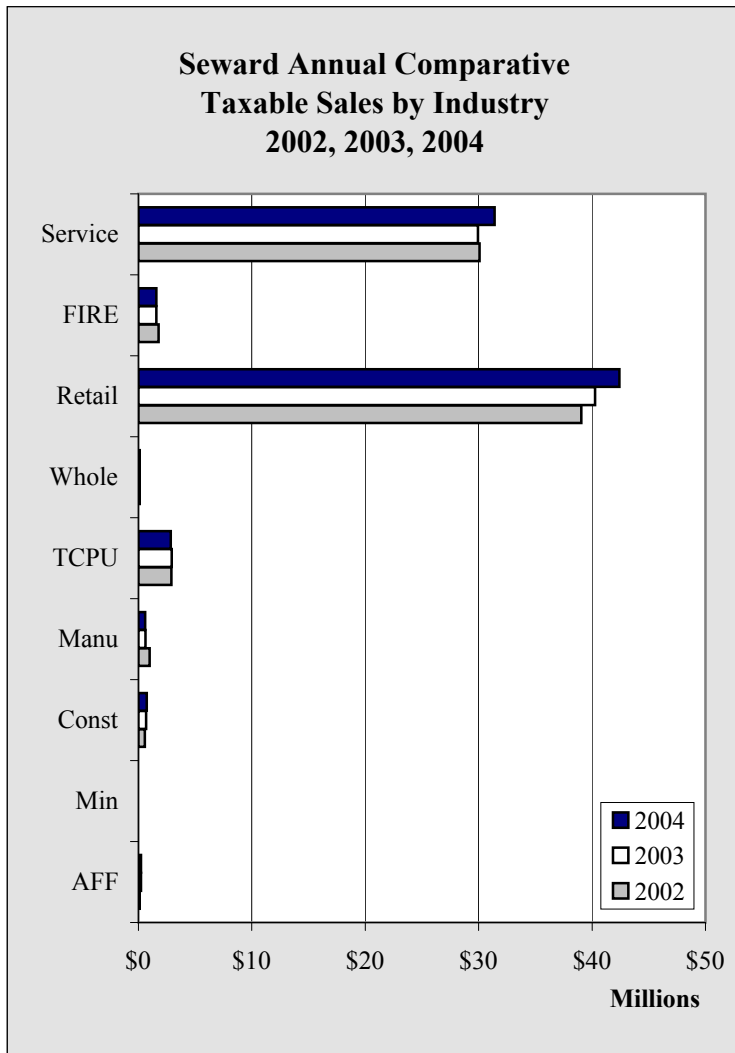

Chart 5.7

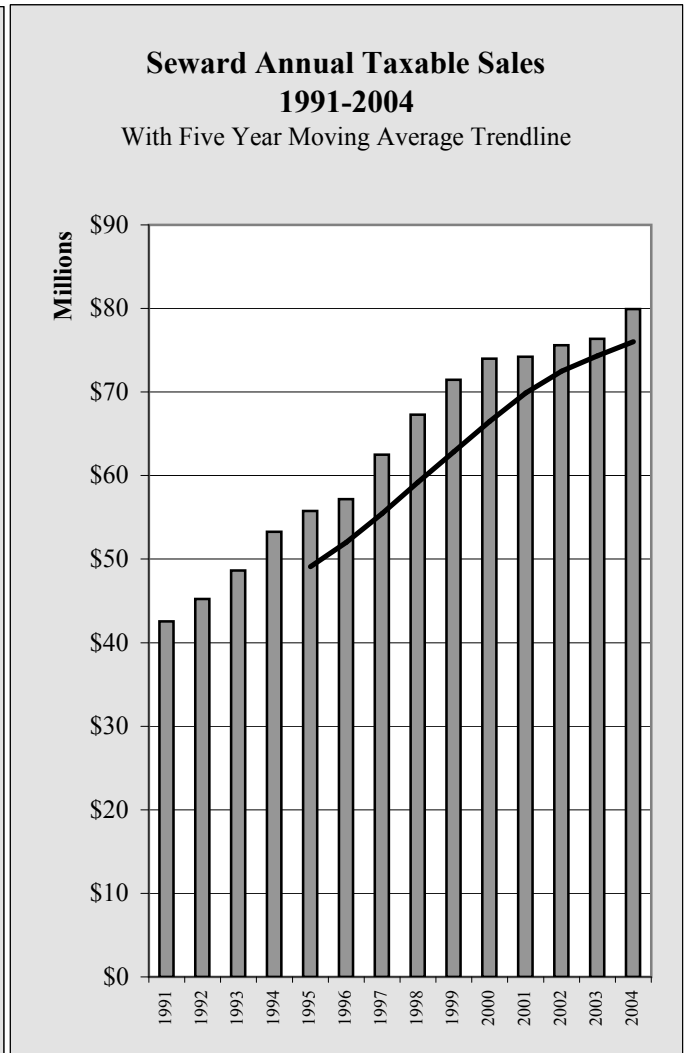

Chart 5.8

Seward Sales

Seward Gross Sales by Industry by Quarter - 2002-2005 - in \$					
	1st Quarter	2nd Quarter	3rd Quarter	4th Quarter	Total
2002					
AFF	20,810	153,308	99,235	24,693	298,046
Min	48,952	131,150	133,354	63,985	377,441
Const	3,040,364	2,363,700	2,223,341	3,456,899	11,084,304
Manu	1,974,606	3,261,062	3,854,201	2,450,766	11,540,635
TCPU	2,253,103	3,404,989	5,193,908	2,174,323	13,026,323
Whole	386,897	671,893	755,749	394,120	2,208,659
Retail	7,932,221	15,310,055	21,049,806	8,308,672	52,600,754
FIRE	1,790,625	2,345,636	2,473,329	986,236	7,595,826
Service	5,506,435	12,743,583	20,938,726	4,446,394	43,635,138
Govt	0	0	0	0	0
Total	22,954,013	40,385,376	56,721,649	22,306,088	142,367,126
2003					
AFF	35,450	180,817	233,386	39,444	489,097
Min	67,921	49,589	49,094	23,151	189,755
Const	3,401,454	10,116,956	9,666,381	5,696,421	28,881,212
Manu	1,468,277	3,785,614	2,466,178	2,726,812	10,446,881
TCPU	2,084,901	3,313,681	5,201,510	2,369,763	12,969,855
Whole	385,079	682,756	888,555	644,189	2,600,579
Retail	7,796,709	14,977,089	21,297,449	9,521,774	53,593,021
FIRE	1,394,159	2,106,421	2,068,760	1,987,789	7,557,129
Service	4,299,310	11,771,230	19,836,458	4,325,071	40,232,069
Govt	0	0	0	0	0
Total	20,933,260	46,984,153	61,707,771	27,334,414	156,959,598
2004					
AFF	54,549	271,027	248,373	77,769	651,718
Min	24,996	78,789	89,202	35,416	228,403
Const	3,306,762	4,487,357	6,884,443	16,811,964	31,490,526
Manu	892,586	1,922,115	3,515,011	884,871	7,214,583
TCPU	2,592,442	3,233,313	3,570,845	2,306,293	11,702,893
Whole	544,648	910,240	1,199,749	1,298,948	3,953,585
Retail	8,616,690	17,930,784	24,148,081	9,345,585	60,041,140
FIRE	1,407,043	1,663,066	2,516,118	1,621,044	7,207,271
Service	3,726,982	12,249,362	21,748,303	5,920,882	43,645,529
Govt	0	0	0	0	0
Total	21,166,698	42,746,053	63,920,125	38,302,772	166,135,648
2005					
					Year to Date
AFF	30,789				30,789
Min	32,647				32,647
Const	6,127,292				6,127,292
Manu	939,970				939,970
TCPU	2,741,108				2,741,108
Whole	520,186				520,186
Retail	9,025,663				9,025,663
FIRE	860,232				860,232
Service	3,809,268				3,809,268
Govt	0				0
Total	24,087,155				24,087,155

Table 5.5

Seward Sales

Seward Taxable Sales by Industry by Quarter - 2002-2005 - in \$					
	1st Quarter	2nd Quarter	3rd Quarter	4th Quarter	Total
2002					
AFF	6,729	57,747	39,602	10,443	114,521
Min	0	0	0	0	0
Const	128,807	140,758	155,433	140,292	565,290
Manu	115,801	299,221	451,494	122,143	988,659
TCPU	560,857	780,744	991,036	583,578	2,916,215
Whole	12,026	38,741	39,460	16,800	107,027
Retail	5,387,940	11,179,774	16,466,497	6,006,749	39,040,960
FIRE	354,630	488,696	593,326	343,944	1,780,596
Service	2,484,254	9,190,793	15,601,212	2,809,169	30,085,428
Govt	0	0	0	0	0
Total	9,051,044	22,176,474	34,338,060	10,033,118	75,598,696
2003					
AFF	11,673	70,505	116,949	18,196	217,323
Min	0	1,754	1,701	0	3,455
Const	126,874	190,057	174,588	192,071	683,590
Manu	144,853	157,138	183,847	143,810	629,648
TCPU	588,465	806,530	941,349	585,325	2,921,669
Whole	15,297	40,058	49,420	14,245	119,020
Retail	5,598,838	11,465,828	16,898,663	6,306,836	40,270,165
FIRE	330,069	415,752	530,822	316,440	1,593,083
Service	2,473,272	8,931,959	15,812,543	2,720,011	29,937,785
Govt	0	0	0	0	0
Total	9,289,341	22,079,581	34,709,882	10,296,934	76,375,738
2004					
AFF	11,923	77,870	129,744	7,800	227,337
Min	0	0	0	0	0
Const	167,430	198,782	187,781	184,187	738,180
Manu	131,626	162,634	163,756	147,012	605,028
TCPU	581,778	758,614	1,009,472	503,592	2,853,456
Whole	23,473	34,969	34,753	14,723	107,918
Retail	5,826,218	11,944,392	18,197,996	6,443,870	42,412,476
FIRE	295,698	394,778	563,136	329,459	1,583,071
Service	2,455,335	9,413,992	16,788,412	2,744,306	31,402,045
Govt	0	0	0	0	0
Total	9,493,481	22,986,031	37,075,050	10,374,949	79,929,511
2005					
				Year to Date	
AFF	8,489				8,489
Min	0				0
Const	151,989				151,989
Manu	79,282				79,282
TCPU	583,500				583,500
Whole	13,977				13,977
Retail	6,305,957				6,305,957
FIRE	261,416				261,416
Service	2,538,939				2,538,939
Govt	0				0
Total	9,943,549				9,943,549

Table 5.6

Seward Construction Permitting

Seward 1st Quarter Permit Values by Type - 1999-2005 - in \$

	1999	2000	2001	2002	2003	2004	2005	Annual Change
Residential - New	0	230,000	0	120,000	118,000	0	1,055,000	NA
Residential - Add/Alter	5,200	0	30,200	25,496	57,500	48,000	6,300	-86.9%
Commercial - New	0	85,000	0	0	72,000	7,500,000	206,000	-97.3%
Commercial - Add/Alter	1,035,350	40,300	386,500	335,944	1,657,855	193,600	240,000	24.0%
TOTAL	1,040,550	355,300	416,700	481,440	1,905,355	7,741,600	1,507,300	-80.5%
Annual Change		-65.9%	17.3%	15.5%	295.8%	306.3%	-80.5%	

Table 5.7

Seward 1st Quarter Permit Values by Type - 1988-2005

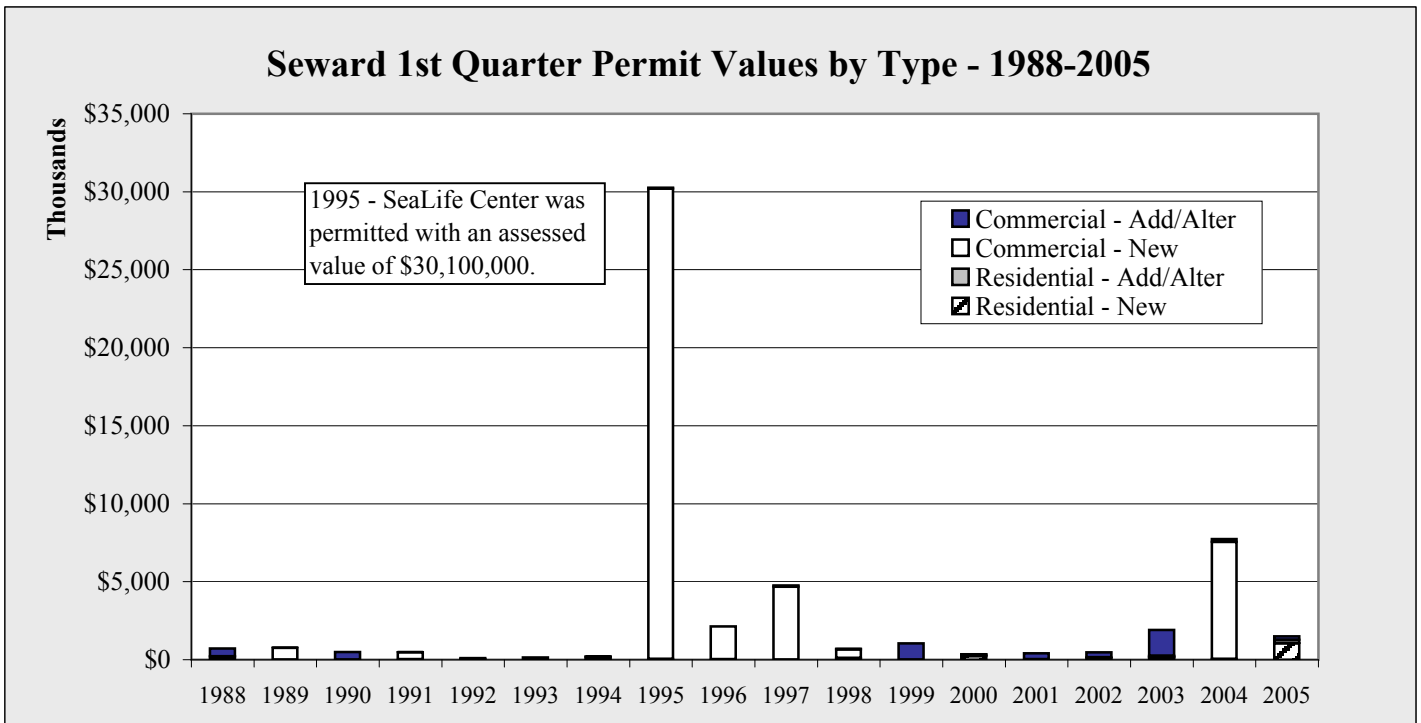

Chart 5.9

Seward 1st Quarter Permit Values Percent by Type - 2005

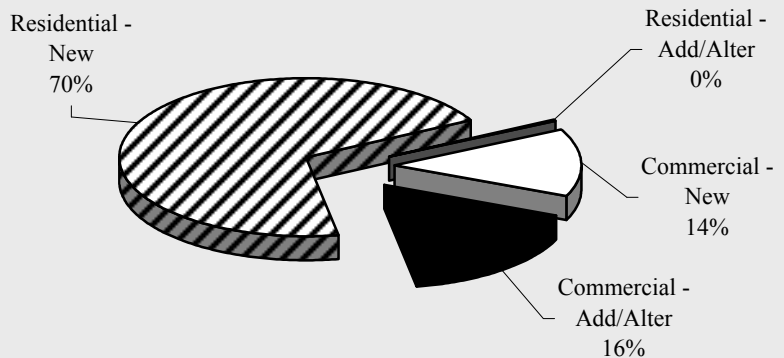

Chart 5.10

Seward Construction Permitting

Seward 1st Quarter Permit Volume by Type - 1999-2005

	1999	2000	2001	2002	2003	2004	2005	Annual Change
Residential - New	0	1	0	1	1	0	4	NA
Residential - Add/Alter	1	0	4	3	2	2	3	50.0%
Commercial - New	0	1	0	0	1	1	2	100.0%
Commercial - Add/Alter	4	3	7	6	7	4	4	0.0%
TOTAL	5	5	11	10	11	7	13	85.7%
Annual Change		0.0%	120.0%	-9.1%	10.0%	-36.4%	85.7%	

Table 5.8

Seward 1st Quarter Permit Volume by Type - 1988-2005

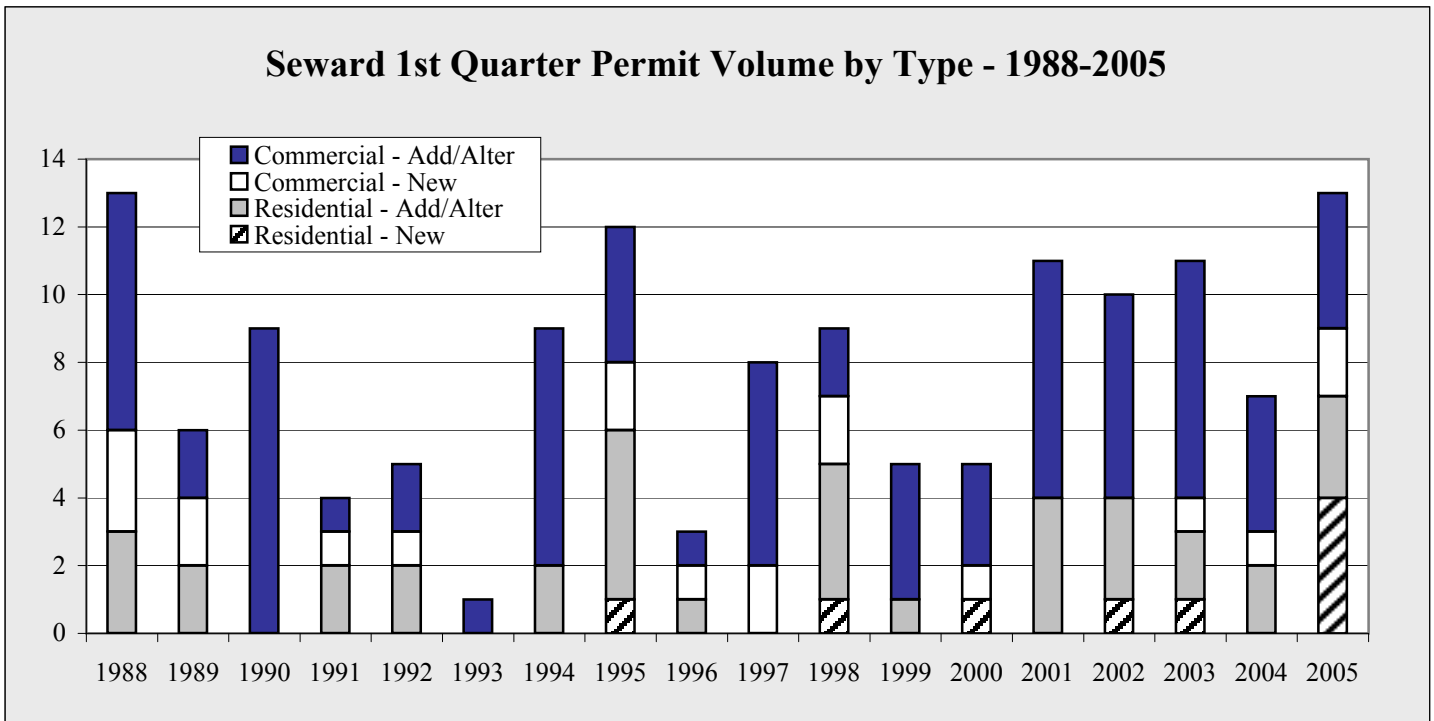

Chart 5.11

Seward 1st Quarter Permit Volume Percent by Type - 2005

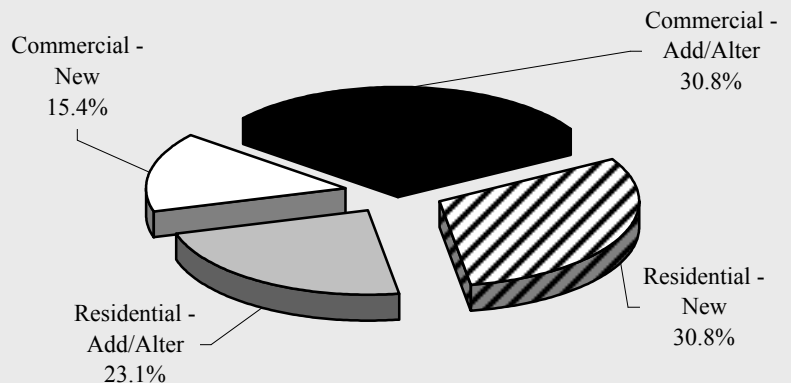

Chart 5.12

Seward Construction Permitting

Seward Annual Permit Values by Type - 1998-2004 - in \$

	1998	1999	2000	2001	2002	2003	2004	Annual Change
Residential - New	1,145,000	1,217,400	1,023,000	450,000	725,000	1,077,500	2,130,000	97.7%
Residential - Add/Alter	240,543	256,600	446,000	344,214	242,008	294,500	500,400	69.9%
Commercial - New	4,925,232	1,393,275	825,000	486,028	6,144,730	4,290,000	13,018,800	203.5%
Commercial - Add/Alter	437,086	1,374,138	1,157,565	1,436,739	798,965	2,320,765	2,061,950	-11.2%
TOTAL	6,747,861	4,241,413	3,451,565	2,716,981	7,910,703	7,982,765	17,711,150	121.9%
Annual Change		-37.1%	-18.6%	-21.3%	191.2%	0.9%	121.9%	

Table 5.9

Seward Annual Permit Values by Type - 1988-2004

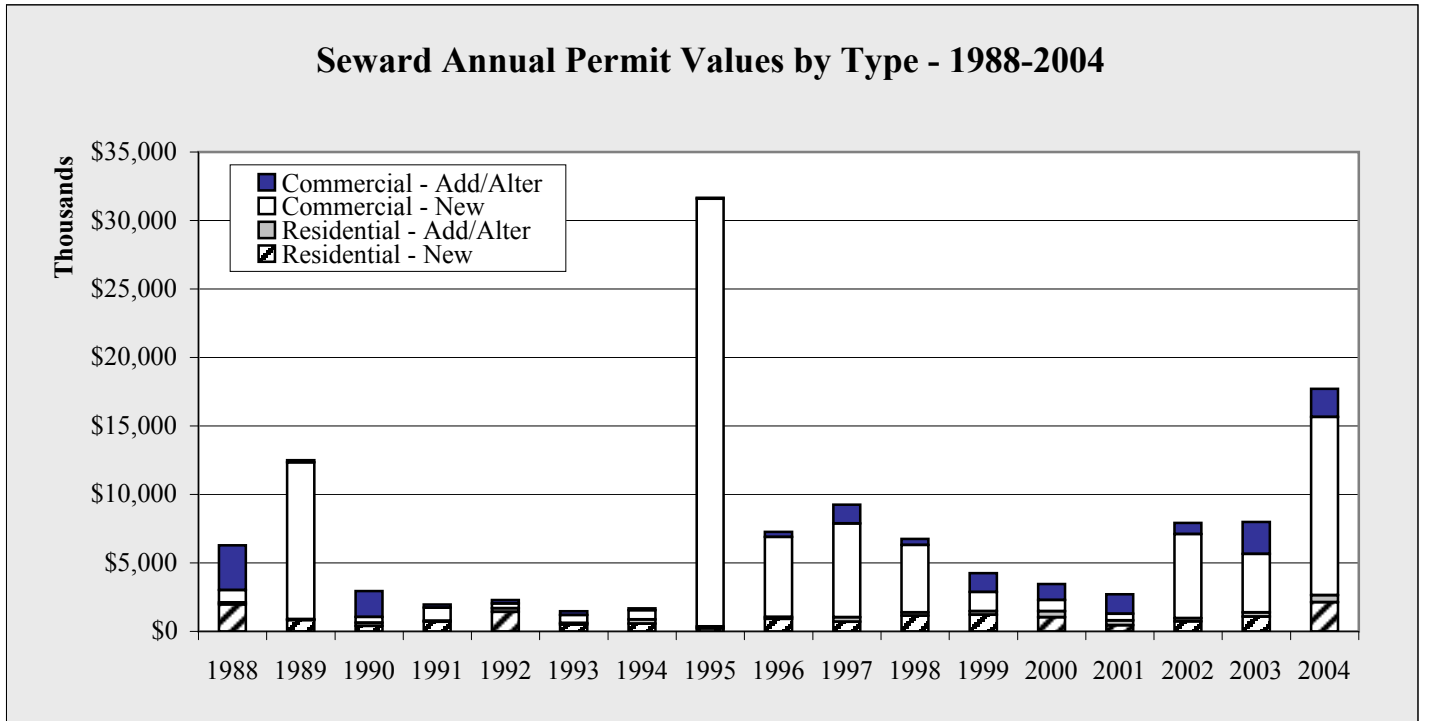

Chart 5.13

Seward Annual Permit Values Percent by Type - 2004

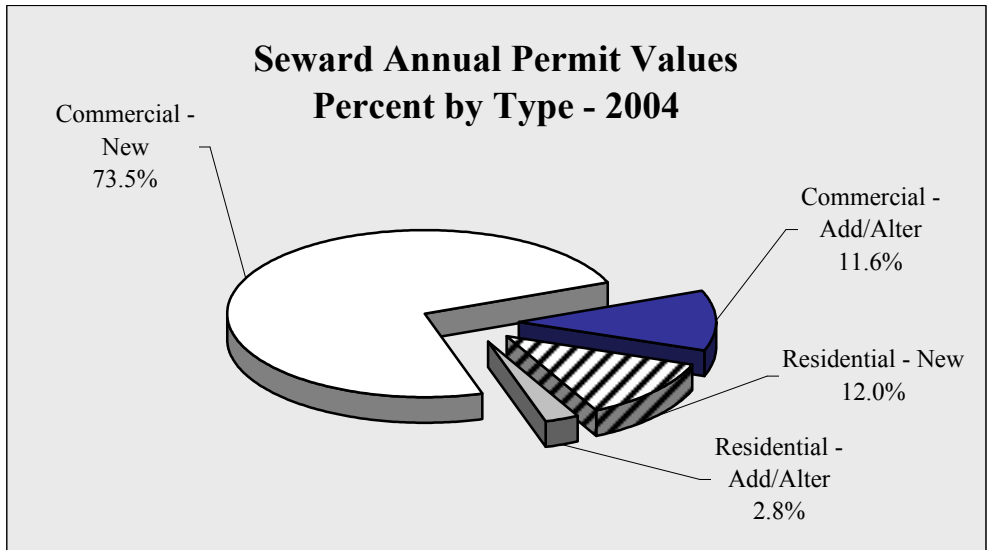

Chart 5.14

Seward Construction Permitting

Seward Annual Permit Volume by Type - 1998-2004

	1998	1999	2000	2001	2002	2003	2004	Annual Change
Residential - New	9	10	5	3	4	8	12	50.0%
Residential - Add/Alter	18	15	19	18	25	11	15	36.4%
Commercial - New	10	7	8	6	8	7	4	-42.9%
Commercial - Add/Alter	12	24	19	21	27	24	23	-4.2%
TOTAL	49	56	51	48	64	50	54	8.0%
Annual Change		14.3%	-8.9%	-5.9%	33.3%	-21.9%	8.0%	

Table 5.10

Seward Annual Permit Volume by Type - 1988-2004

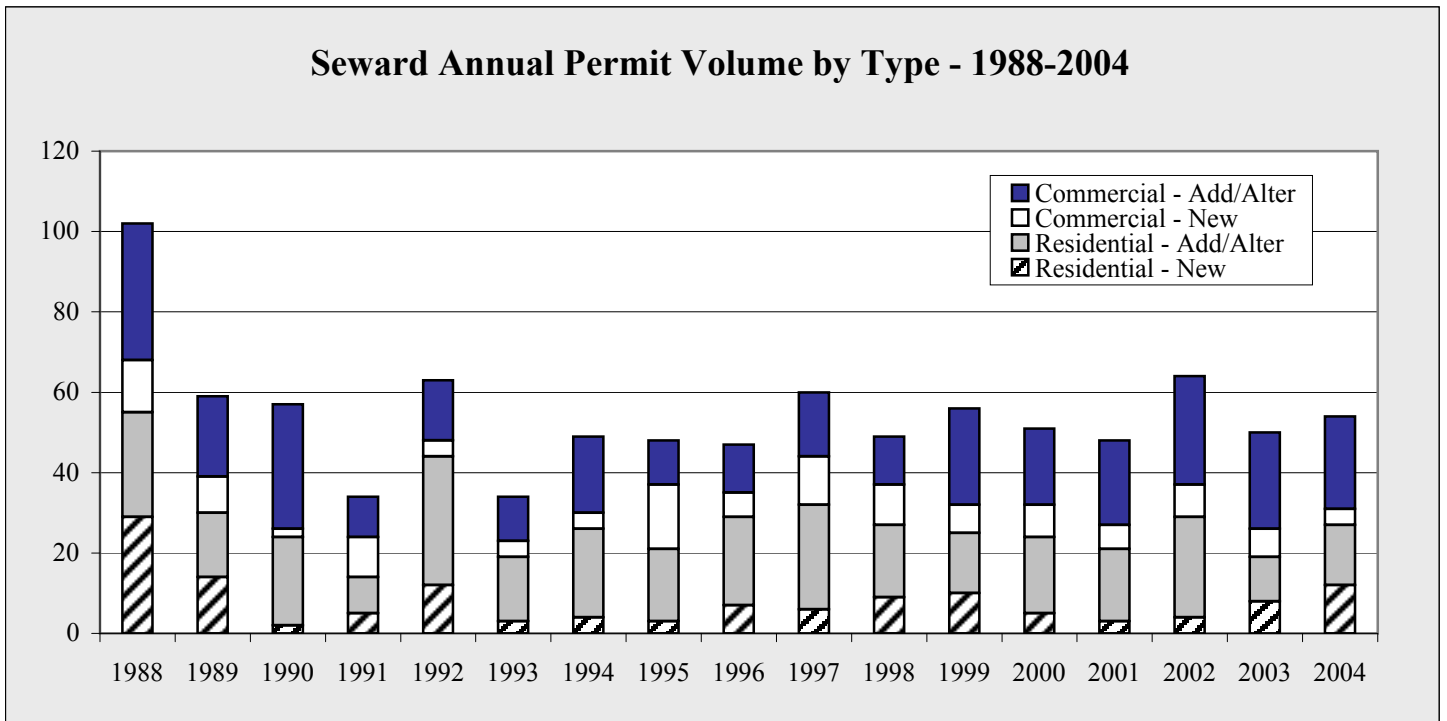

Chart 5.15

Seward Annual Permit Volume Percent by Type - 2004

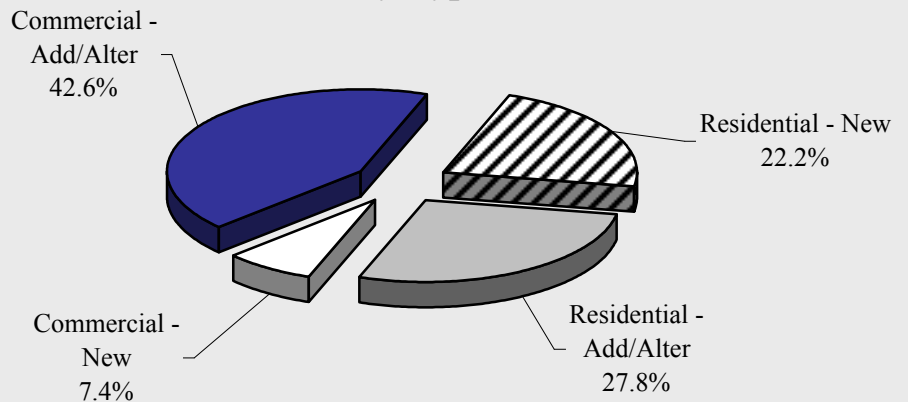

Chart 5.16

Seward Construction Permitting

Seward Annual Permit Values by Quarter by Type - 1998-2005 - in \$					
	1st Quarter	2nd Quarter	3rd Quarter	4th Quarter	Total
1998					
Residential - New	85,000	643,000	417,000	0	1,145,000
Residential - Add/Alter	25,043	122,000	59,000	34,500	240,543
Commercial - New	536,232	75,000	4,054,000	260,000	4,925,232
Commercial - Add/Alter	56,800	119,000	256,186	5,100	437,086
TOTAL	703,075	959,000	4,786,186	299,600	6,747,861
1999					
Residential - New	0	585,000	509,400	123,000	1,217,400
Residential - Add/Alter	5,200	164,500	71,900	15,000	256,600
Commercial - New	0	250,000	903,275	240,000	1,393,275
Commercial - Add/Alter	1,035,350	82,614	131,174	125,000	1,374,138
TOTAL	1,040,550	1,082,114	1,615,749	503,000	4,241,413
2000					
Residential - New	230,000	530,000	263,000	0	1,023,000
Residential - Add/Alter	0	67,600	39,000	339,400	446,000
Commercial - New	85,000	210,000	330,000	200,000	825,000
Commercial - Add/Alter	40,300	957,800	79,465	80,000	1,157,565
TOTAL	355,300	1,765,400	711,465	619,400	3,451,565
2001					
Residential - New	0	0	150,000	300,000	450,000
Residential Add/Alter	30,200	73,000	136,014	105,000	344,214
Commercial - New	0	155,000	331,028	0	486,028
Commercial - Add/Alter	386,500	438,239	25,000	587,000	1,436,739
TOTAL	416,700	666,239	642,042	992,000	2,716,981
2002					
Residential - New	120,000	400,000	205,000	0	725,000
Residential Add/Alter	25,496	169,157	27,555	19,800	242,008
Commercial - New	0	3,294,730	750,000	2,100,000	6,144,730
Commercial - Add/Alter	335,944	25,000	325,021	113,000	798,965
TOTAL	481,440	3,888,887	1,307,576	2,232,800	7,910,703
2003					
Residential - New	118,000	215,000	744,500	0	1,077,500
Residential - Add/Alter	57,500	100,000	87,000	50,000	294,500
Commercial - New	72,000	3,313,000	900,000	5,000	4,290,000
Commercial - Add/Alter	1,657,855	44,010	101,400	517,500	2,320,765
TOTAL	1,905,355	3,672,010	1,832,900	572,500	7,982,765
2004					
Residential - New	0	873,000	1,257,000	0	2,130,000
Residential - Add/Alter	48,000	144,900	299,500	8,000	500,400
Commercial - New	7,500,000	5,000,000	518,800	0	13,018,800
Commercial - Add/Alter	193,600	1,426,000	191,000	251,350	2,061,950
TOTAL	7,741,600	7,443,900	2,266,300	259,350	17,711,150
2005					
	Year to Date				
Residential - New	1,055,000				1,055,000
Residential - Add/Alter	6,300				6,300
Commercial - New	206,000				206,000
Commercial - Add/Alter	240,000				240,000
TOTAL	1,507,300				1,507,300

Table 5.11

Seward Construction Permitting

Seward Annual Permit Volume by Quarter by Type - 1998-2005					
	1st Quarter	2nd Quarter	3rd Quarter	4th Quarter	Total
1998					
Residential - New	1	6	2	0	9
Residential - Add/Alter	4	4	5	5	18
Commercial - New	2	3	4	1	10
Commercial - Add/Alter	2	7	2	1	12
TOTAL	9	20	13	7	49
1999					
Residential - New	0	5	4	1	10
Residential - Add/Alter	1	7	5	2	15
Commercial - New	0	1	5	1	7
Commercial - Add/Alter	4	5	9	6	24
TOTAL	5	18	23	10	56
2000					
Residential - New	1	2	2	0	5
Residential - Add/Alter	0	8	7	4	19
Commercial - New	1	3	3	1	8
Commercial - Add/Alter	3	7	5	4	19
TOTAL	5	20	17	9	51
2001					
Residential - New	0	0	1	2	3
Residential Add/Alter	4	3	9	2	18
Commercial - New	0	3	3	0	6
Commercial - Add/Alter	7	8	1	5	21
TOTAL	11	14	14	9	48
2002					
Residential - New	1	1	2	0	4
Residential Add/Alter	3	15	3	4	25
Commercial - New	0	4	1	3	8
Commercial - Add/Alter	6	9	8	4	27
TOTAL	10	29	14	11	64
2003					
Residential - New	1	2	5	0	8
Residential - Add/Alter	2	3	5	1	11
Commercial - New	1	4	1	1	7
Commercial - Add/Alter	7	4	4	9	24
TOTAL	11	13	15	11	50
2004					
Residential - New	0	4	8	0	12
Residential - Add/Alter	2	7	5	1	15
Commercial - New	1	1	2	0	4
Commercial - Add/Alter	4	9	4	6	23
TOTAL	7	21	19	7	54
2005					Year to Date
Residential - New	4				4
Residential - Add/Alter	3				3
Commercial - New	2				2
Commercial - Add/Alter	4				4
TOTAL	13				13

Table 5.12

Seward Cost of Food

Cost of food data is collected by the University of Alaska, Fairbanks Cooperative Extension. Each quarter the Cooperative Extension surveys up to three grocers in communities throughout the state to determine the cost of food for one week. Specific guidelines are presented to the surveyors regarding item size and sale price for 104 items.

SEWARD								
	March 1997	March 1998	March 2001*	March 2002	March 2003	March 2004	March 2005	Annual Change
Sales Tax Rate	5.0	5.0	5.0	5.0	5.0	6.0	6.0	NA
Percent of Food Unavailable	0.0	0.0	5.0	2.0	2.0	0.0	2.0	NA
Child, 1 year	18.0	19.9	18.3	19.1	18.1	21.3	20.0	-6.1%
Child, 2 years	0.0	0.0	0.0	19.1	18.1	21.0	19.8	-5.7%
Children 3-5 years of age	24.3	21.8	20.1	20.9	19.8	23.0	21.8	-5.2%
Children 6-8 years of age	26.1	29.0	26.7	27.9	26.5	31.1	29.3	-5.8%
Children 9-11 years of age	29.6	32.9	30.3	31.6	30.0	34.9	32.9	-5.7%
Males 12-14 years of age	33.4	37.2	34.3	35.7	33.8	39.3	37.2	-5.3%
Males 15-19 years of age	34.4	38.3	35.4	36.9	34.8	40.5	38.3	-5.3%
Males 20-50 years of age	34.3	38.1	35.3	36.9	34.9	40.6	38.4	-5.3%
Males 51 and older	32.7	36.4	33.6	35.2	33.2	38.7	36.7	-5.4%
Females 12-19 years of age	28.8	32.0	29.6	30.9	29.1	34.0	32.2	-5.3%
Females 20-50 years of age	30.1	33.4	30.9	32.3	30.5	35.5	33.5	-5.6%
Females 51 and older	29.2	32.3	30.0	31.4	29.6	34.4	32.6	-5.3%
Family of 2, 20-50 years of age	68.7	78.8	72.8	76.1	72.0	83.7	79.1	-5.4%
Family of 2, 51 years and older	68.1	75.6	70.0	73.3	69.2	80.5	76.2	-5.3%
Family of 4, children 1-5 years	101.9	113.2	104.6	109.2	103.3	120.1	113.6	-5.4%
Family of 4, children 6-11 years	120.0	133.4	123.2	128.7	121.8	142.1	134.1	-5.6%
Electricity, 1000 kWh	120.4	128.4	134.1	139.6	125.7	139.3	140.9	1.1%
Heating Oil, 55 gal	69.3	93.5	91.3	65.5	87.5	85.3	116.1	36.1%
Gasoline, auto, 55 gal	84.1	73.7	101.2	90.2	107.8	102.3	119.4	16.7%
Lumber, 2X4X8	3.6	2.8	2.8	3.0	3.3	2.2	3.8	69.1%
Propane, 100 lb. Refill	0.0	0.0	49.5	48.4	59.7	56.6	67.3	18.8%

Table 5.13

* March 1999 and 2000 information is not available.

Seward Cost of Food

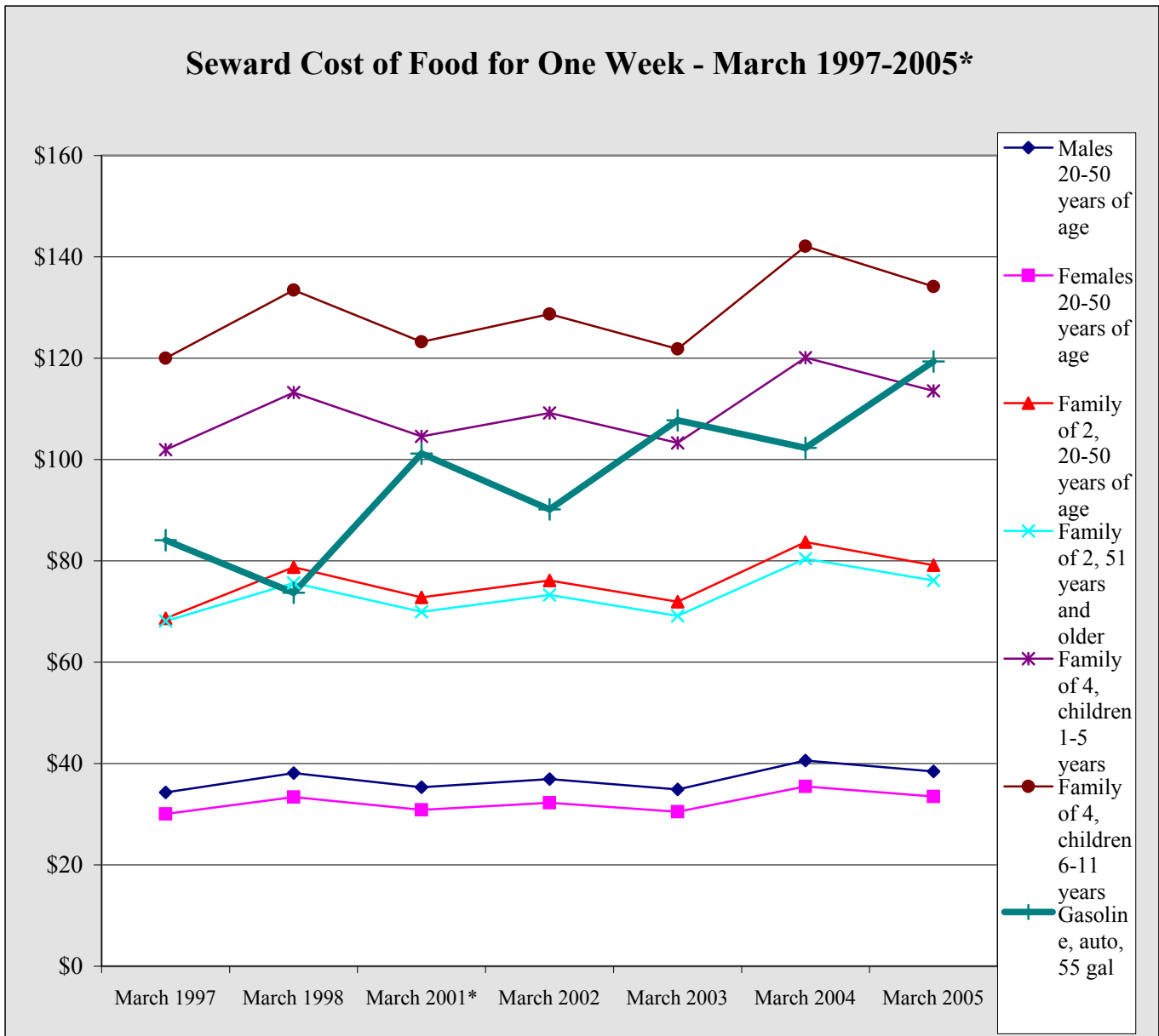

Chart 5.17

* March 1999 and 2000 information is not available.

Seward Population

Seward Select Detail - 1990 v 2000

Population				
	1990	2000	Percent Change	Percent of Total
Total Population	2,699	2,830	4.9%	100.0%
Male	1,587	1,699	7.1%	60.0%
Female	1,112	1,131	1.7%	40.0%
Under 5 years	205	164	-20.0%	5.8%
5 to 9 years	177	162	-8.5%	5.7%
10 to 14 years	164	177	7.9%	6.3%
15 to 19 years	135	194	43.7%	6.9%
20 to 24 years	210	178	-15.2%	6.3%
25 to 34 years	611	431	-29.5%	15.2%
35 to 44 years	563	585	3.9%	20.7%
45 to 54 years	282	501	77.7%	17.7%
55 to 59 years	79	146	84.8%	5.2%
60 to 64 years	104	81	-22.1%	2.9%
65 to 74 years	115	134	16.5%	4.7%
75 to 84 years	39	56	43.6%	2.0%
85 years and over	15	21	40.0%	0.7%
Median Age	32.6	37.1	13.8%	NA
18 Years and Over	643	2,210	243.7%	78.1%
Male		1,381	NA	NA
Female		829	NA	NA
65 Years and Over	169	211	24.9%	7.5%
Male		99	NA	NA
Female		112	NA	NA
Place of Birth				
Native Born	2,593	2,695	3.9%	95.2%
Born in Alaska		1,081	NA	38.2%
Born in other state		1,594	NA	56.3%
Foreign Born	106	135	27.4%	4.8%
Naturalized Citizen		81	NA	2.9%
Not a Citizen		54	NA	1.9%
Veteran Status				
Civilian veterans	436	404	-7.3%	18.5%
Educational Attainment				
Population 25 years and over				1,956
Less than 9th grade	54	61	13.0%	3.1%
9th-12th, no diploma	157	200	27.4%	10.2%
High School Diploma	696	748	7.5%	38.2%
College, no degree	510	521	2.2%	26.6%
Associate Degree	110	115	4.5%	5.9%
Bachelor's Degree	181	198	9.4%	10.1%
Graduate, Profess Degree	97	113	16.5%	5.8%
Percent HS Grad	88.3%	86.7%	-1.8%	NA
Percent Bachelor's +	15.4%	15.9%	3.2%	NA

Housing				
	1990	2000	Percent Change	Percent of Total
Total Households	886	917	3.5%	100.0%
Family Households	536	556	3.7%	60.6%
With Children Under 18		327	NA	35.7%
Married Couple Family	399	409	2.5%	44.6%
With Own Children Under 18		215	NA	23.4%
Female Householder, no husband present		111	NA	12.1%
With Own Children Under 18		87	NA	9.5%
Average Household Size	2.47	2.40	NA	0.3%
Average Family Size		3.04	NA	0.3%
Total Housing Units	1,010	1,058	NA	115.4%
Occupied Housing Units	886	917	3.5%	100.0%
Vacant Housing Units	124	141	13.7%	15.4%
Seasonal, Recreational, Occasional Use	27	63	133.3%	6.9%
Owner Vacancy Rate	1.6%	2.5%	NA	NA
Rental Vacancy Rate	9.7%	8.4%	NA	NA
Owner Occupied Units	420	461	9.8%	50.3%
Renter Occupied Units	466	456	-2.1%	49.7%
Marital Status (over 15)		2,320	NA	NA
Never married		734	NA	31.6%
Married except separated		1,078	NA	46.5%
Separated		43	NA	1.9%
Widowed		119	NA	5.1%
Divorced		346	NA	14.9%
Disabled, Noninstitutionalized				
Population 5 to 20		551	NA	100.0%
With a Disability		33	NA	6.0%
Population 21 to 64		1,414	NA	100.0%
With a Disability		271	NA	19.2%
Percent Employed		49.4%	NA	NA
Without a Disability		1,143	NA	80.8%
Percent Employed		70.5%	NA	NA
Income in 1999 - Families				
		Total	553	
Less than \$10,000	35	29	-17.1%	5.2%
\$10,000 - \$14,999	28	33	17.9%	6.0%
\$15,000 - \$24,999	67	50	-25.4%	9.0%
\$25,000 - \$34,999	68	53	-22.1%	9.6%
\$35,000 - \$49,999	91	73	-19.8%	13.2%
\$50,000 - \$74,999	114	155	36.0%	28.0%
\$75,000 - \$99,999	76	79	3.9%	14.3%
\$100,000 - \$149,999	41	55	34.1%	9.9%
\$150,000 - \$199,999	16	17	6.3%	3.1%
\$200,000 or more	NA	9	NA	1.6%
Median Income - \$	47,500	54,904	15.6%	NA

Table 5.14

Sales Sales

Soldotna 1st Quarter Gross Sales by Industry - 1999-2005 - in \$

	1999	2000	2001	2002	2003	2004	2005	Annual Change
AFF	97,954	158,182	215,220	231,354	287,421	556,985	577,172	3.6%
Min	47,052	71,262	49,472	98,101	110,629	92,181	90,039	-2.3%
Const	2,307,621	3,044,411	4,015,371	3,228,042	3,997,918	2,956,843	4,089,120	38.3%
Manu	481,304	641,545	967,938	900,894	1,129,391	543,783	513,059	-5.7%
TCPU	3,991,637	4,039,609	4,764,455	3,685,725	4,211,327	4,796,956	5,315,503	10.8%
Whole	5,799,487	7,278,779	6,827,062	8,072,050	7,309,289	9,720,151	2,084,468	-78.6%
Retail	30,513,785	31,528,136	34,715,249	36,487,247	36,787,701	39,606,915	40,334,405	1.8%
FIRE	2,100,160	1,976,395	2,166,881	2,258,203	2,461,298	3,032,921	2,707,082	-10.7%
Service	6,078,154	6,456,290	7,074,122	7,363,434	7,926,425	8,597,849	8,646,908	0.6%
Govt	12,826	7,287	6,507	6,700	12,319	6,904	1,897	-72.5%
Total	51,429,980	55,201,896	60,802,277	62,331,750	64,233,718	69,911,488	64,359,653	-7.9%
Annual Change		7.3%	10.1%	2.5%	3.1%	8.8%	-7.9%	

Table 6.1

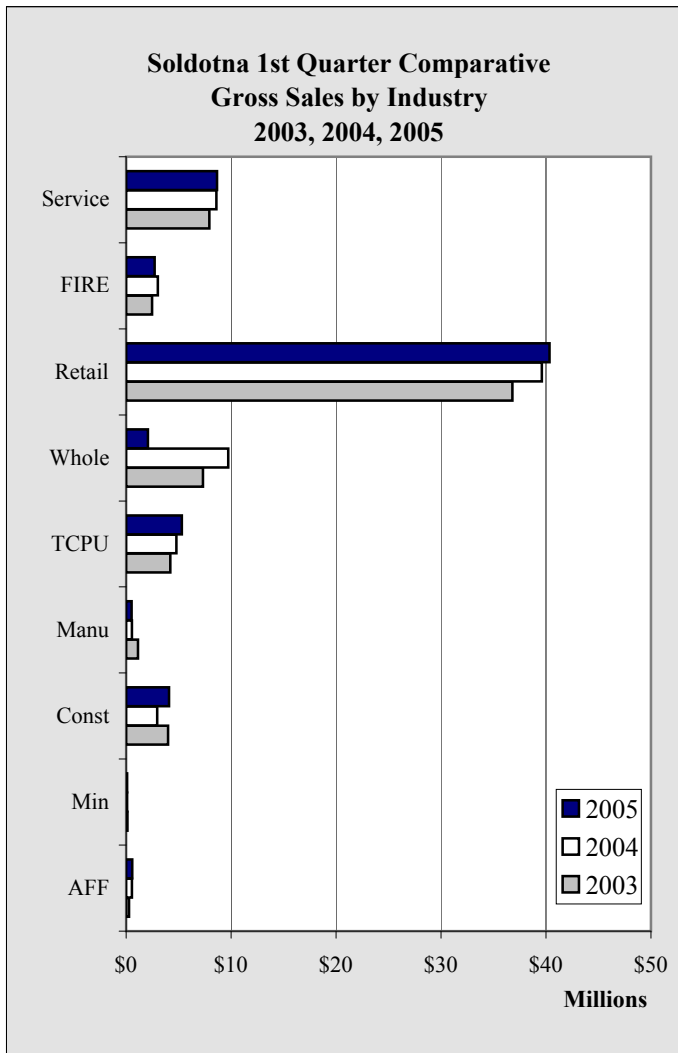

Chart 6.1

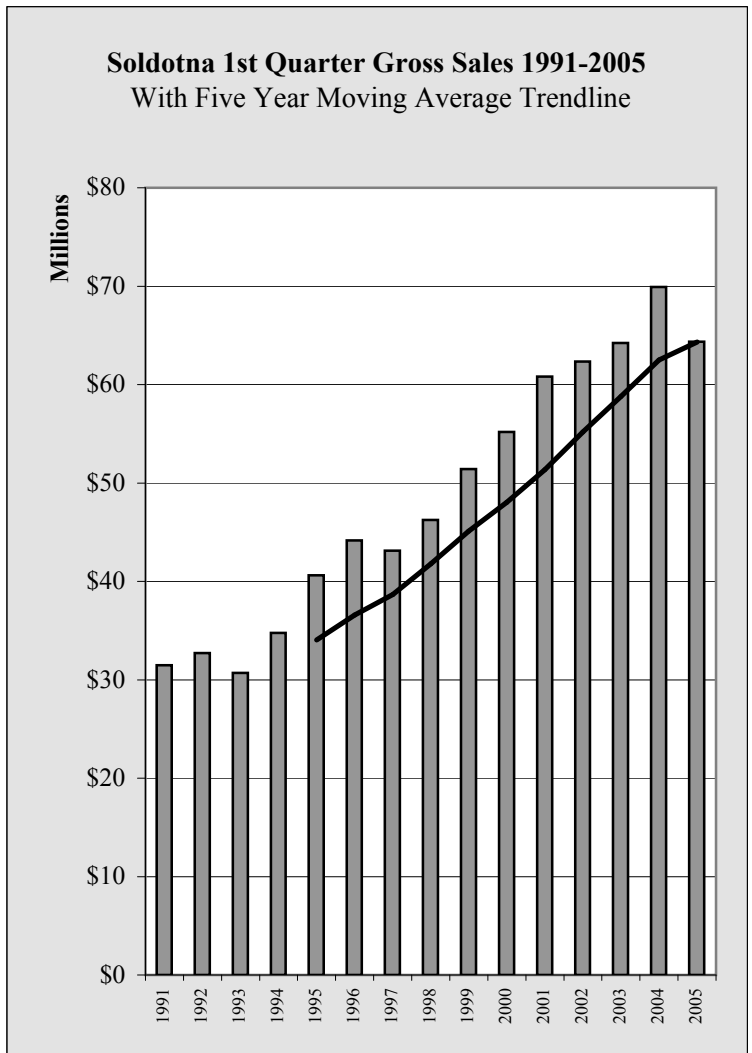

Chart 6.2

Sales Tax

Soldotna 1st Quarter Taxable Sales by Industry - 1999-2005 - in \$

	1999	2000	2001	2002	2003	2004	2005	Annual Change
AFF	94,556	148,104	183,856	185,252	167,593	219,231	179,414	-18.2%
Min	0	1,148	7,612	6,447	9,374	6,675	6,145	-7.9%
Const	295,263	316,000	234,518	283,099	301,760	316,960	327,458	3.3%
Manu	199,670	194,558	199,966	181,486	219,705	197,841	199,659	0.9%
TCPU	2,544,919	2,608,749	2,584,193	2,752,273	3,219,035	3,338,198	3,298,150	-1.2%
Whole	59,914	71,213	124,637	135,437	173,053	154,053	117,758	-23.6%
Retail	21,325,306	22,423,668	25,030,145	25,570,526	25,769,374	28,539,627	29,559,836	3.6%
FIRE	858,013	860,411	1,072,034	1,170,633	1,141,419	961,092	951,012	-1.0%
Service	3,049,461	3,033,282	3,048,909	3,444,755	3,449,990	3,642,747	3,430,305	-5.8%
Govt	12,826	7,287	6,507	6,700	12,319	6,904	1,897	-72.5%
Total	28,439,928	29,664,420	32,492,377	33,736,608	34,463,622	37,383,328	38,071,634	1.8%
Annual Change		4.3%	9.5%	3.8%	2.2%	8.5%	1.8%	

Table 6.2

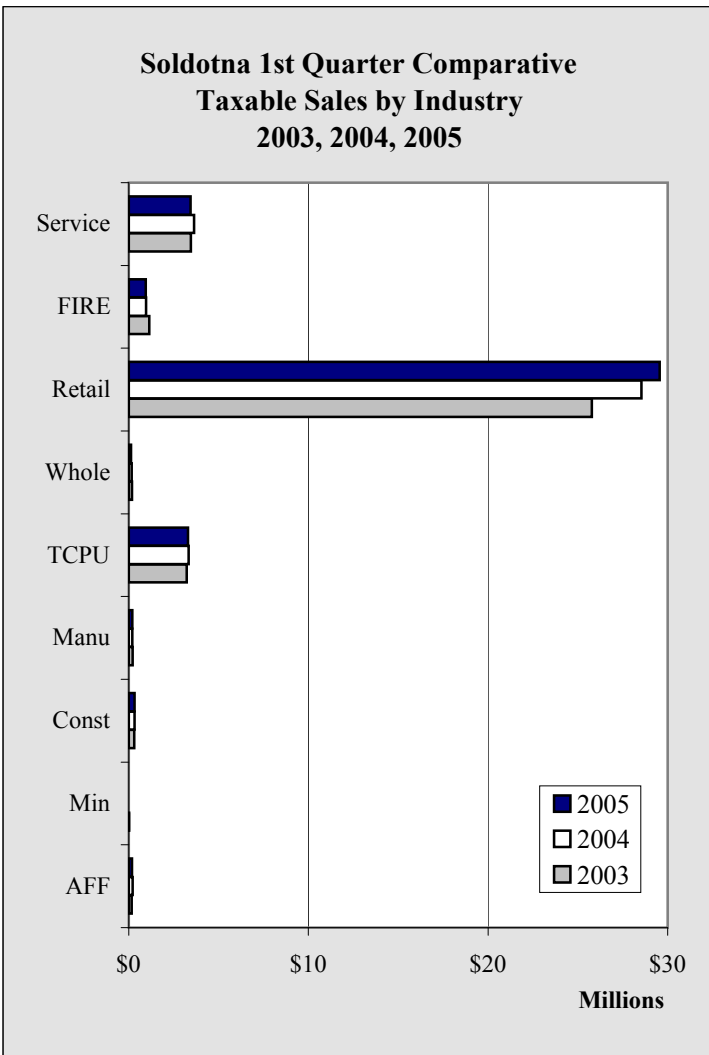

Chart 6.3

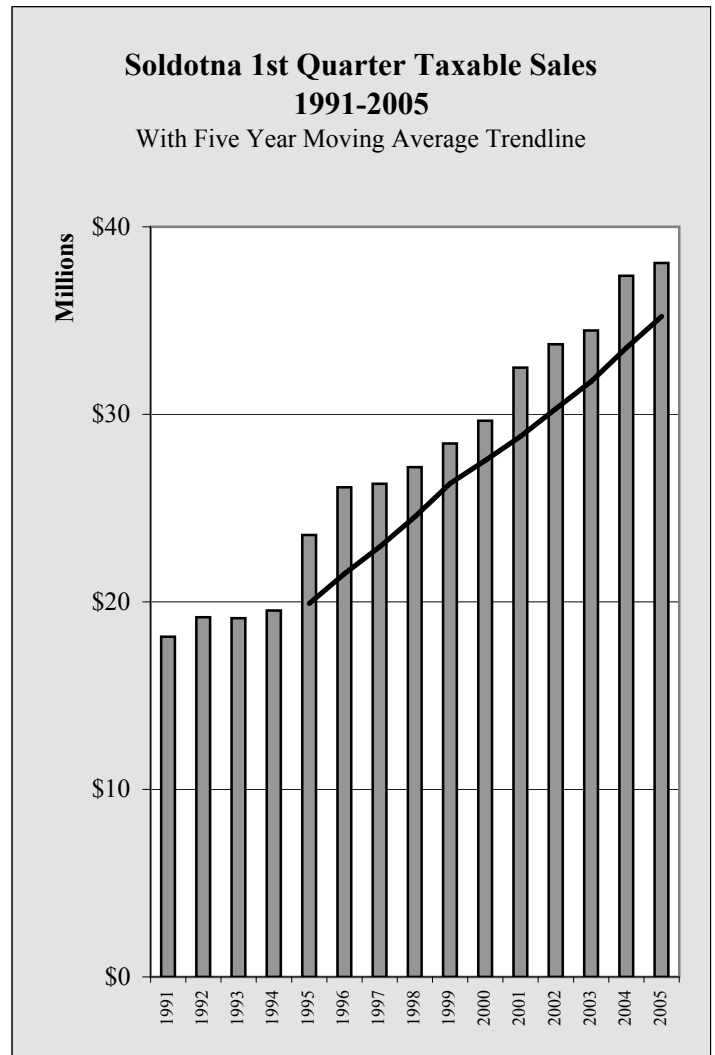

Chart 6.4

Soldotna Sales

Soldotna Annual Gross Sales by Industry - 1998-2004 - in \$

	1998	1999	2000	2001	2002	2003	2004	Annual Change
AFF	689,389	954,143	1,727,448	1,664,917	1,853,591	2,523,473	3,223,216	27.7%
Min	2,729,541	306,689	305,525	305,091	410,684	450,504	548,472	21.7%
Const	20,205,240	17,075,443	20,761,485	19,395,458	22,467,091	20,813,302	27,758,056	33.4%
Manu	3,192,979	3,210,218	5,446,988	5,938,040	6,301,658	7,729,281	4,338,040	-43.9%
TCPU	14,308,591	17,467,668	15,708,998	17,799,215	15,900,605	16,342,600	20,221,946	23.7%
Whole	14,626,150	32,515,047	32,610,279	31,467,653	40,201,769	34,368,869	28,770,110	-16.3%
Retail	157,774,054	166,898,488	170,201,586	187,606,859	191,944,180	204,741,275	217,650,893	6.3%
FIRE	7,365,455	8,509,983	10,210,170	10,232,574	10,465,959	10,733,557	11,881,330	10.7%
Service	29,884,044	30,622,659	32,265,770	34,689,321	36,330,903	40,028,395	46,691,122	16.6%
Govt	18,221	28,399	17,062	19,103	22,579	41,717	20,979	-49.7%
Total	250,793,664	277,588,737	289,255,311	309,118,231	325,899,019	337,772,973	361,104,164	6.9%
Annual Change		10.7%	4.2%	6.9%	5.4%	3.6%	6.9%	

Table 6.3

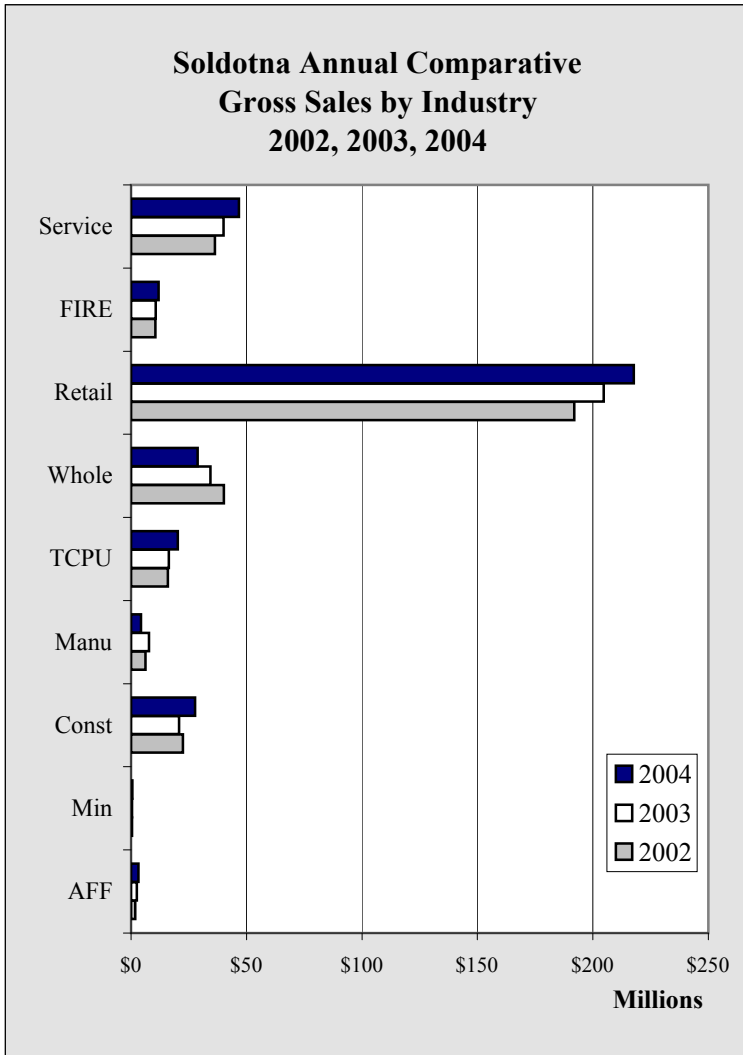

Chart 6.5

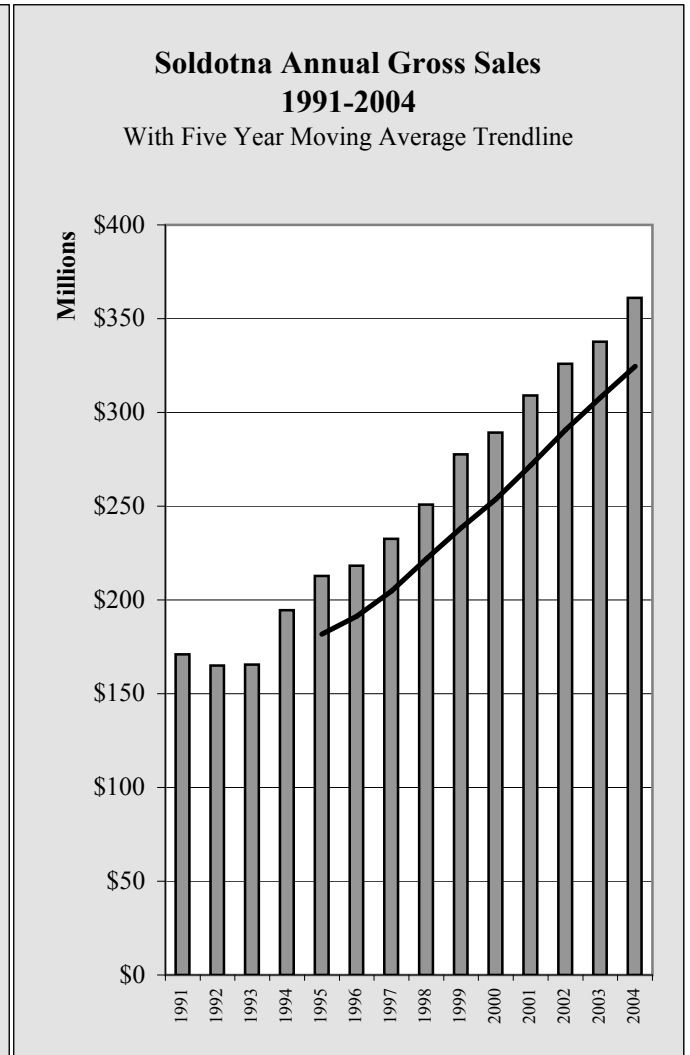

Chart 6.6

Sales Sales

Soldotna Annual Taxable Sales by Industry - 1998-2004 - in \$

	1998	1999	2000	2001	2002	2003	2004	Annual Change
AFF	466,912	697,062	921,908	1,117,793	1,043,812	1,176,634	1,123,088	-4.6%
Min	8,010	5,675	11,333	35,080	33,278	33,067	20,326	-38.5%
Const	1,320,297	1,471,239	1,233,755	1,173,265	1,317,838	1,590,497	1,412,936	-11.2%
Manu	1,439,440	1,467,864	1,567,147	1,638,254	1,635,572	1,674,325	1,663,082	-0.7%
TCPU	9,374,360	10,378,566	10,311,502	10,527,433	11,178,060	12,295,182	12,421,267	1.0%
Whole	369,062	322,925	715,161	786,443	763,236	997,320	805,376	-19.2%
Retail	115,732,671	122,401,180	124,618,575	136,194,643	138,178,507	151,168,576	159,827,563	5.7%
FIRE	3,662,452	3,776,435	4,545,775	5,207,613	5,279,203	4,435,121	4,396,348	-0.9%
Service	15,398,236	15,403,419	15,493,910	15,718,811	17,525,783	17,204,443	18,359,304	6.7%
Govt	18,221	28,399	17,062	19,103	22,579	41,717	20,979	-49.7%
Total	147,789,661	155,952,764	159,436,128	172,418,438	176,977,868	190,616,882	200,050,269	4.9%
Annual Change		5.5%	2.2%	8.1%	2.6%	7.7%	4.9%	

Table 6.4

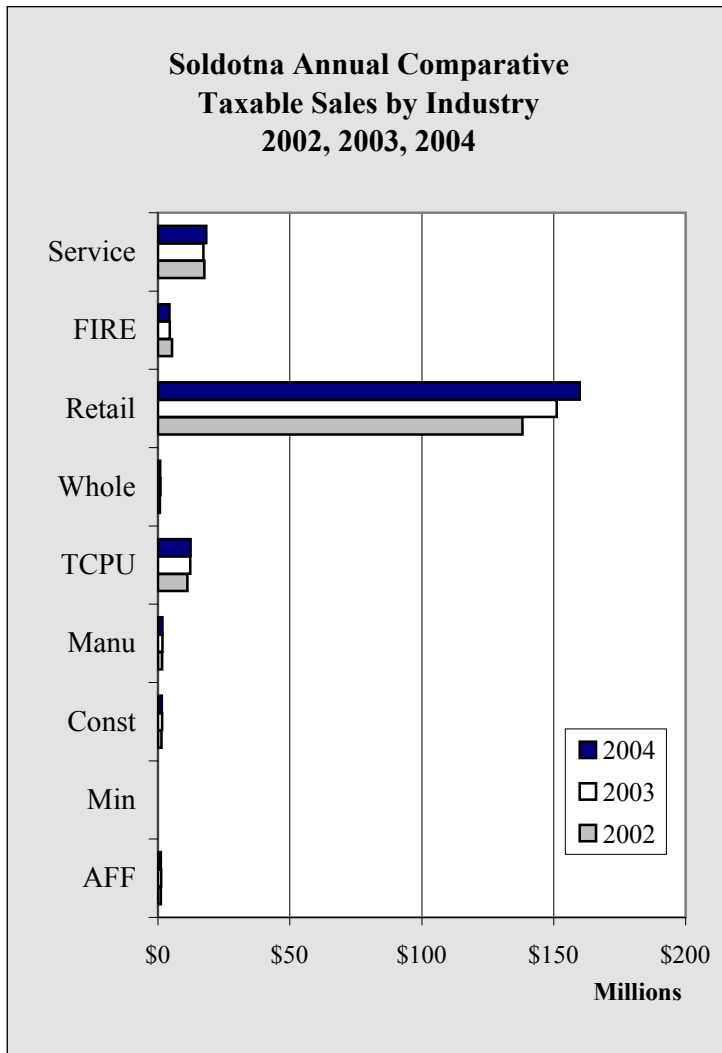

Chart 6.7

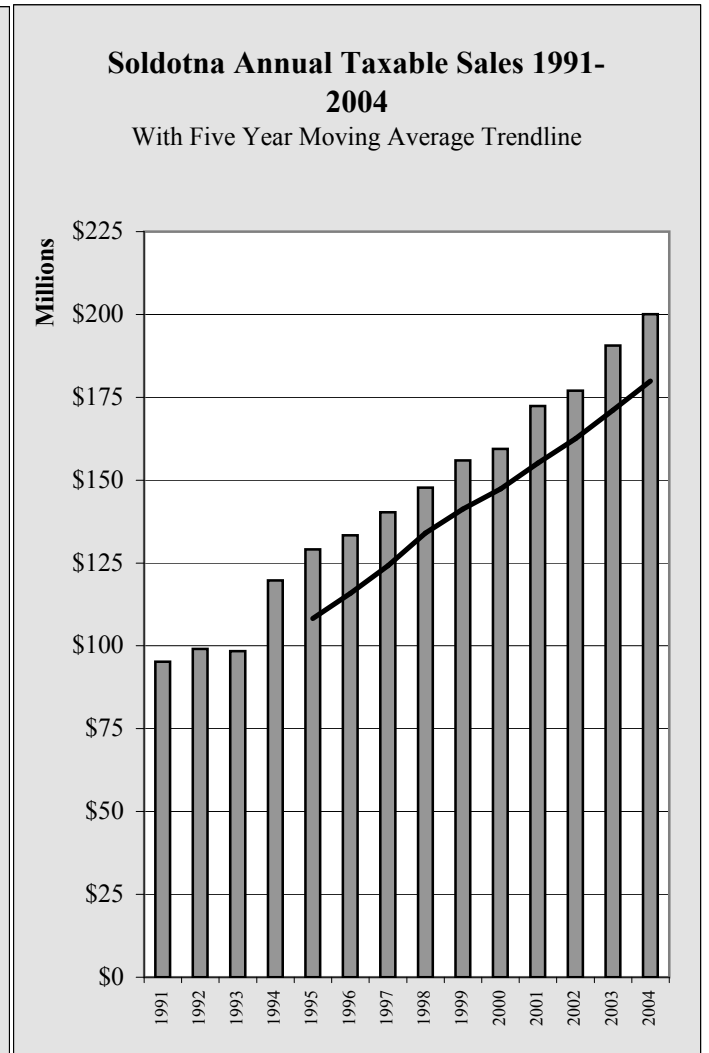

Chart 6.8

Soldotna Sales

Soldotna Gross Sales by Industry by Quarter - 2002-2005 - in \$					
	1st Quarter	2nd Quarter	3rd Quarter	4th Quarter	Total
2002					
AFF	231,354	493,143	667,821	461,273	1,853,591
Min	98,101	106,949	86,164	119,470	410,684
Const	3,228,042	4,934,965	8,313,280	5,990,804	22,467,091
Manu	900,894	1,727,614	2,352,093	1,321,057	6,301,658
TCPU	3,685,725	3,531,451	4,900,494	3,782,935	15,900,605
Whole	8,072,050	7,353,520	12,524,522	12,251,677	40,201,769
Retail	36,487,247	49,060,629	60,884,442	45,511,862	191,944,180
FIRE	2,258,203	2,983,720	2,591,812	2,632,224	10,465,959
Service	7,363,434	9,561,798	11,299,921	8,105,750	36,330,903
Govt	6,700	7,859	4,290	3,730	22,579
Total	62,331,750	79,761,648	103,624,839	80,180,782	325,899,019
2003					
AFF	287,421	558,058	920,446	757,548	2,523,473
Min	110,629	122,012	99,139	118,724	450,504
Const	3,997,918	3,954,148	6,734,379	6,126,857	20,813,302
Manu	1,129,391	2,288,148	2,843,498	1,468,244	7,729,281
TCPU	4,211,327	3,827,252	3,716,921	4,587,100	16,342,600
Whole	7,309,289	9,554,591	10,562,562	6,942,427	34,368,869
Retail	36,787,701	52,189,612	66,012,371	49,751,591	204,741,275
FIRE	2,461,298	2,547,857	2,821,665	2,902,737	10,733,557
Service	7,926,425	10,128,839	12,481,767	9,491,364	40,028,395
Govt	12,319	8,680	12,192	8,526	41,717
Total	64,233,718	85,179,197	106,204,940	82,155,118	337,772,973
2004					
AFF	556,985	645,572	1,043,046	977,613	3,223,216
Min	92,181	154,892	136,149	165,250	548,472
Const	2,956,843	5,879,390	9,245,159	9,676,664	27,758,056
Manu	543,783	1,132,457	1,857,842	803,958	4,338,040
TCPU	4,796,956	4,716,238	5,692,042	5,016,710	20,221,946
Whole	9,720,151	8,967,548	3,326,912	6,755,499	28,770,110
Retail	39,606,915	54,023,404	70,300,859	53,719,715	217,650,893
FIRE	3,032,921	2,956,541	2,822,065	3,069,803	11,881,330
Service	8,597,849	10,824,252	12,751,842	14,517,179	46,691,122
Govt	6,904	8,521	2,880	2,674	20,979
Total	69,911,488	89,308,815	107,178,796	94,705,065	361,104,164
2005					
					Year to Date
AFF	577,172				577,172
Min	90,039				90,039
Const	4,089,120				4,089,120
Manu	513,059				513,059
TCPU	5,315,503				5,315,503
Whole	2,084,468				2,084,468
Retail	40,334,405				40,334,405
FIRE	2,707,082				2,707,082
Service	8,646,908				8,646,908
Govt	1,897				1,897
Total	64,359,653				64,359,653

Table 6.5

Soldotna Sales

Soldotna Taxable Sales by Industry by Quarter - 2002-2005- in \$					
	1st Quarter	2nd Quarter	3rd Quarter	4th Quarter	Total
2002					
AFF	185,252	286,565	393,521	178,474	1,043,812
Min	6,447	7,414	7,836	11,581	33,278
Const	283,099	329,803	369,398	335,538	1,317,838
Manu	181,486	429,327	710,329	314,430	1,635,572
TCPU	2,752,273	2,619,156	2,944,886	2,861,745	11,178,060
Whole	135,437	231,064	251,226	145,509	763,236
Retail	25,570,526	33,723,015	45,546,360	33,338,606	138,178,507
FIRE	1,170,633	1,266,667	1,502,411	1,339,492	5,279,203
Service	3,444,755	4,603,064	5,758,366	3,719,598	17,525,783
Govt	6,700	7,859	4,290	3,730	22,579
Total	33,736,608	43,503,934	57,488,623	42,248,703	176,977,868
2003					
AFF	167,593	297,426	457,868	253,747	1,176,634
Min	9,374	7,401	7,885	8,407	33,067
Const	301,760	430,437	465,297	393,003	1,590,497
Manu	219,705	436,364	739,665	278,591	1,674,325
TCPU	3,219,035	2,964,183	2,959,644	3,152,320	12,295,182
Whole	173,053	288,627	339,309	196,331	997,320
Retail	25,769,374	36,976,302	50,742,487	37,680,413	151,168,576
FIRE	1,141,419	1,151,616	1,159,465	982,621	4,435,121
Service	3,449,990	4,457,613	5,692,459	3,604,381	17,204,443
Govt	12,319	8,680	12,192	8,526	41,717
Total	34,463,622	47,018,649	62,576,271	46,558,340	190,616,882
2004					
AFF	219,231	270,912	444,134	188,811	1,123,088
Min	6,675	5,828	3,030	4,793	20,326
Const	316,960	377,000	368,702	350,274	1,412,936
Manu	197,841	375,725	804,097	285,419	1,663,082
TCPU	3,338,198	2,985,335	2,949,371	3,148,363	12,421,267
Whole	154,053	254,535	263,334	133,454	805,376
Retail	28,539,627	38,707,449	53,991,389	38,589,098	159,827,563
FIRE	961,092	1,130,865	1,284,286	1,020,105	4,396,348
Service	3,642,747	4,894,259	6,071,728	3,750,570	18,359,304
Govt	6,904	8,521	2,880	2,674	20,979
Total	37,383,328	49,010,429	66,182,951	47,473,561	200,050,269
2005					
					Year to Date
AFF	179,414				179,414
Min	6,145				6,145
Const	327,458				327,458
Manu	199,659				199,659
TCPU	3,298,150				3,298,150
Whole	117,758				117,758
Retail	29,559,836				29,559,836
FIRE	951,012				951,012
Service	3,430,305				3,430,305
Govt	1,897				1,897
Total	38,071,634				38,071,634

Table 6.6

Soldotna Construction Permitting

Soldotna 1st Quarter Permit Values by Type - 1999-2005 - in \$

	1999	2000	2001	2002	2003	2004	2005	Annual Change
Residential - New	0	373,929	0	240,849	0	539,297	720,956	33.7%
Residential - Add/Alter	54,000	0	105,160	86,935	57,827	0	261,630	NA
Commercial - New	0	434,273	2,658,578	714,806	0	4,465,026	195,000	-95.6%
Commercial - Add/Alter	29,696	270,000	287,480	163,000	369,191	60,000	243,969	306.6%
TOTAL	83,696	1,078,202	3,051,218	1,205,590	427,018	5,064,323	1,421,555	-71.9%
Annual Change		1188.2%	183.0%	-60.5%	-64.6%	1086.0%	-71.9%	

Table 6.7

Soldotna 1st Quarter Permit Values by Type - 1986-2005

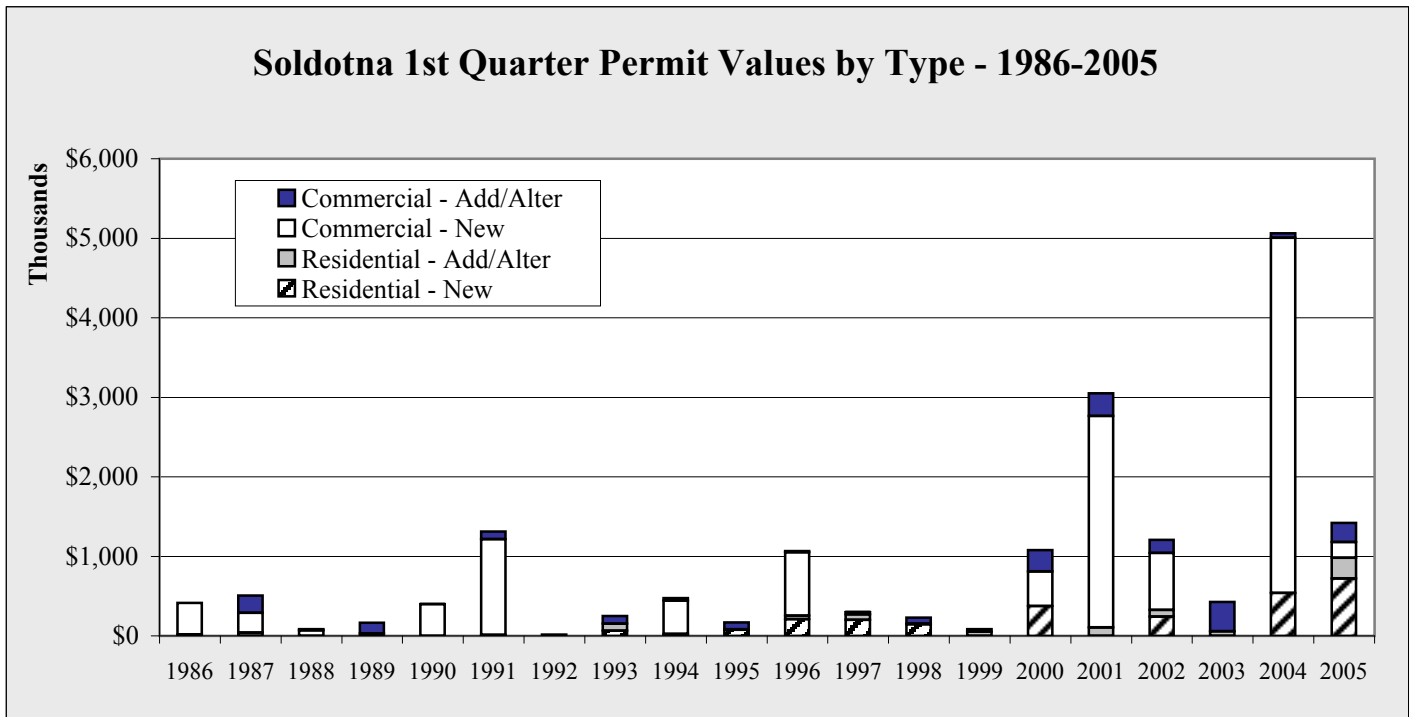

Chart 6.9

Soldotna 1st Quarter Permit Values Percent by Type - 2005

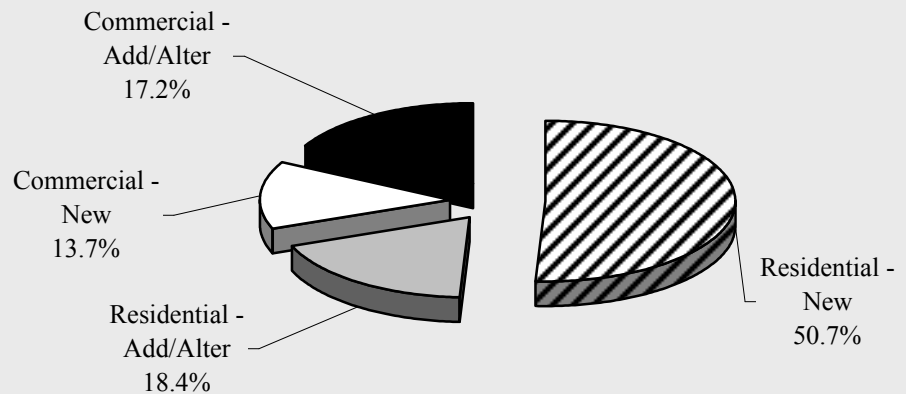

Chart 6.10

Soldotna Construction Permitting

Soldotna 1st Quarter Permit Volume by Type - 1999-2005

	1999	2000	2001	2002	2003	2004	2005	Annual Change
Residential - New	0	2	0	1	0	2	4	100.0%
Residential - Add/Alter	4	0	3	2	3	0	3	NA
Commercial - New	0	1	3	4	0	4	2	-50.0%
Commercial - Add/Alter	6	5	4	4	3	3	7	133.3%
TOTAL	10	8	10	11	6	9	16	77.8%
Annual Change		-20.0%	25.0%	10.0%	-45.5%	50.0%	77.8%	

Table 6.8

Soldotna 1st Quarter Permit Volume by Type - 1986-2005

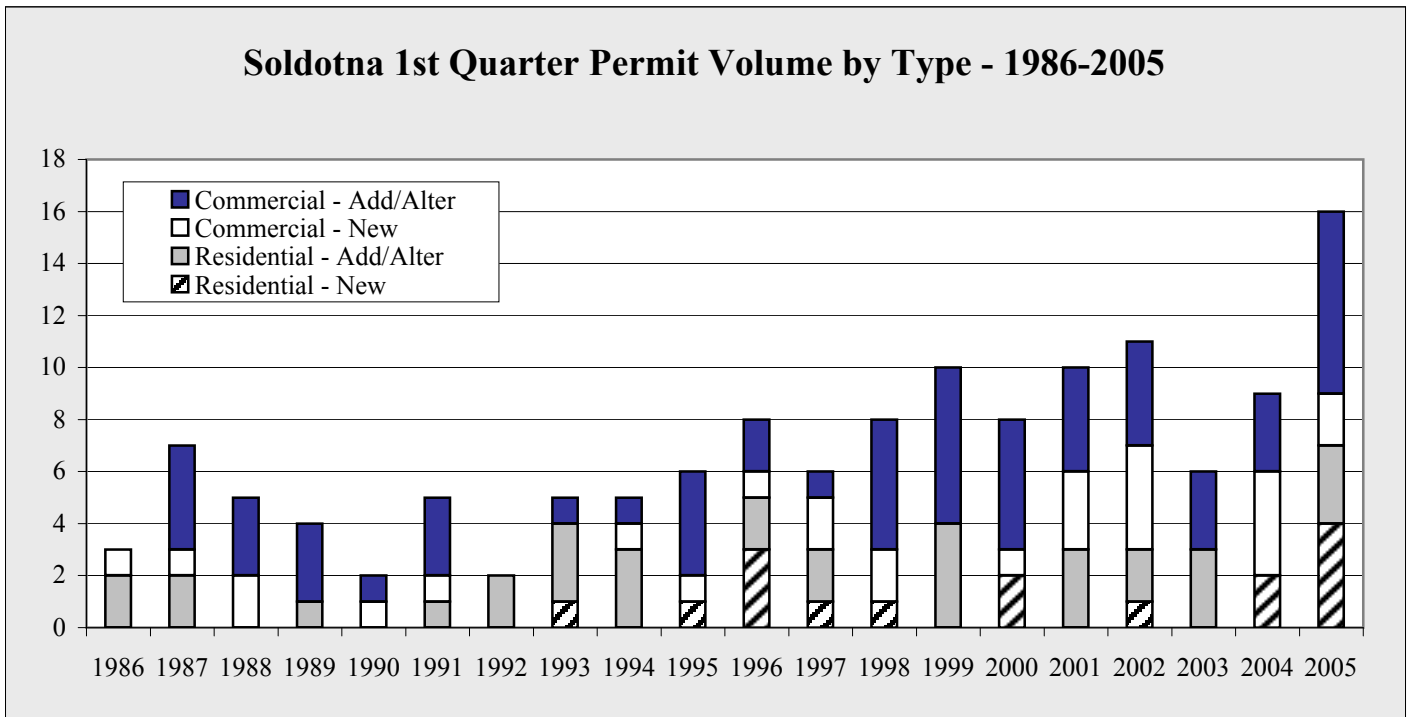

Chart 6.11

Soldotna 1st Quarter Permit Volume Percent by Type - 2005

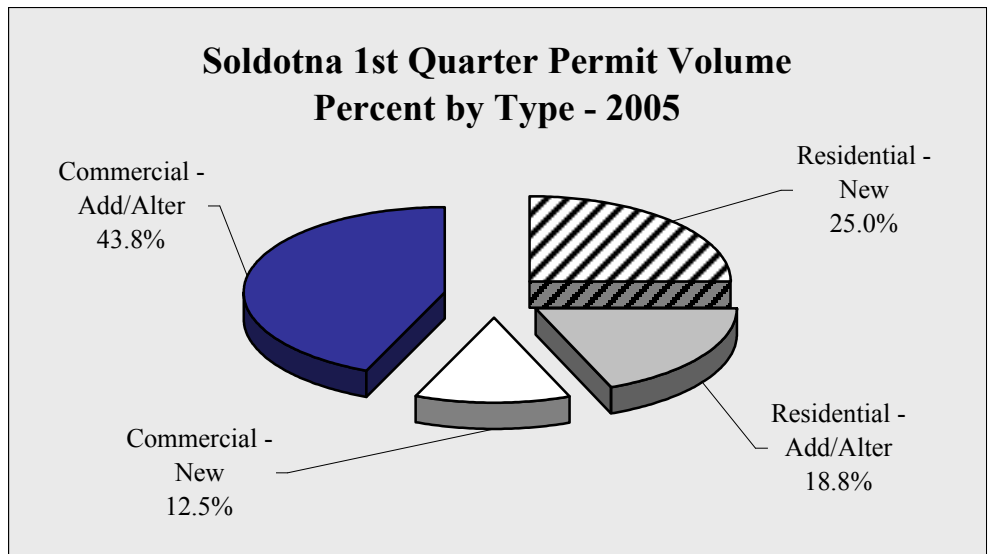

Chart 6.12

Soldotna Construction Permitting

Soldotna Annual Permit Values by Type - 1998-2004 - in \$

	1998	1999	2000	2001	2002	2003	2004	Annual Change
Residential - New	2,347,000	3,048,462	2,709,018	3,873,853	3,181,344	3,073,933	3,881,344	26.3%
Residential - Add/Alter	237,060	377,228	365,239	357,495	755,187	263,629	277,984	5.4%
Commercial - New	5,890,665	5,501,539	3,924,064	3,288,822	4,397,059	3,769,181	28,329,025	651.6%
Commercial - Add/Alter	1,147,092	577,891	1,169,099	1,434,802	2,830,304	845,554	4,808,573	468.7%
TOTAL	9,621,817	9,505,120	8,167,420	8,954,972	11,163,894	7,952,297	37,296,926	369.0%
Annual Change		-1.2%	-14.1%	9.6%	24.7%	-28.8%	369.0%	

Table 6.9

Soldotna Annual Permit Values by Type - 1986-2004

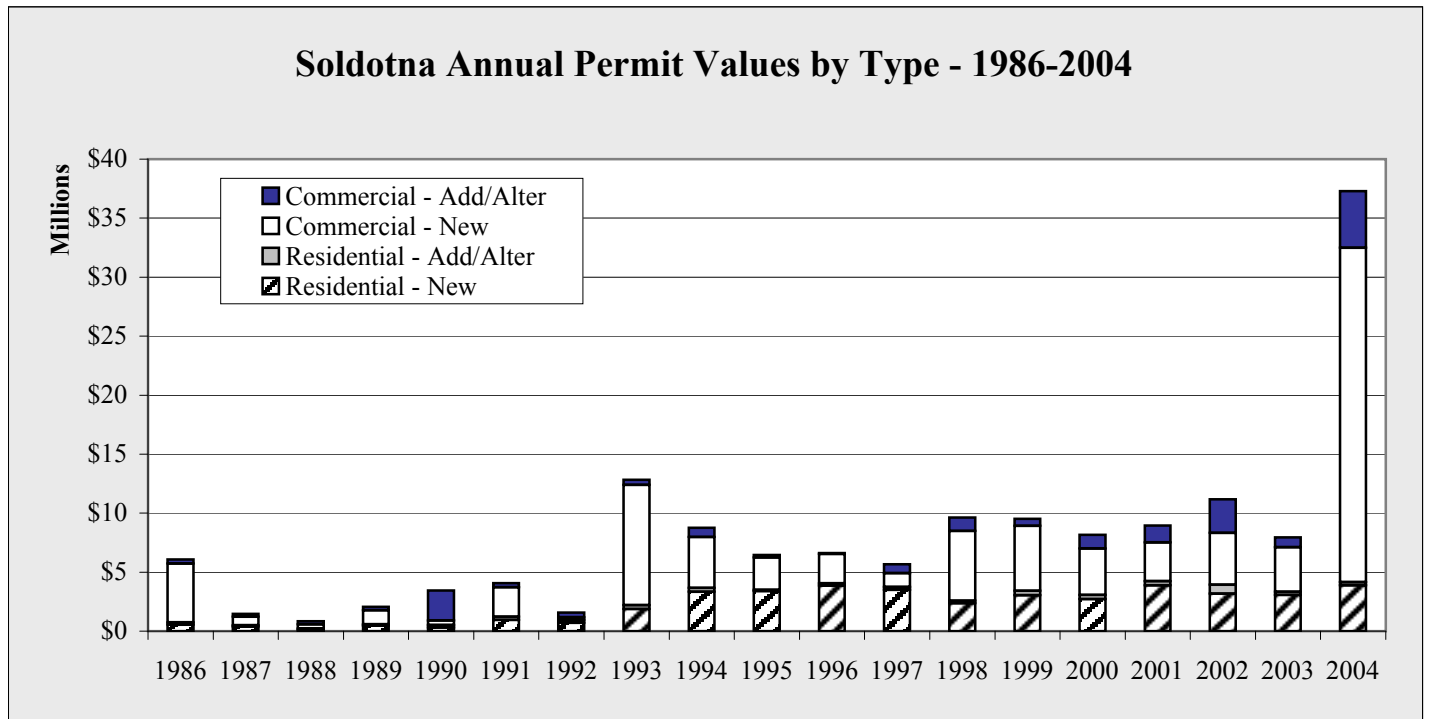

Chart 6.13

Soldotna Annual Permit Value Percent by Type - 2004

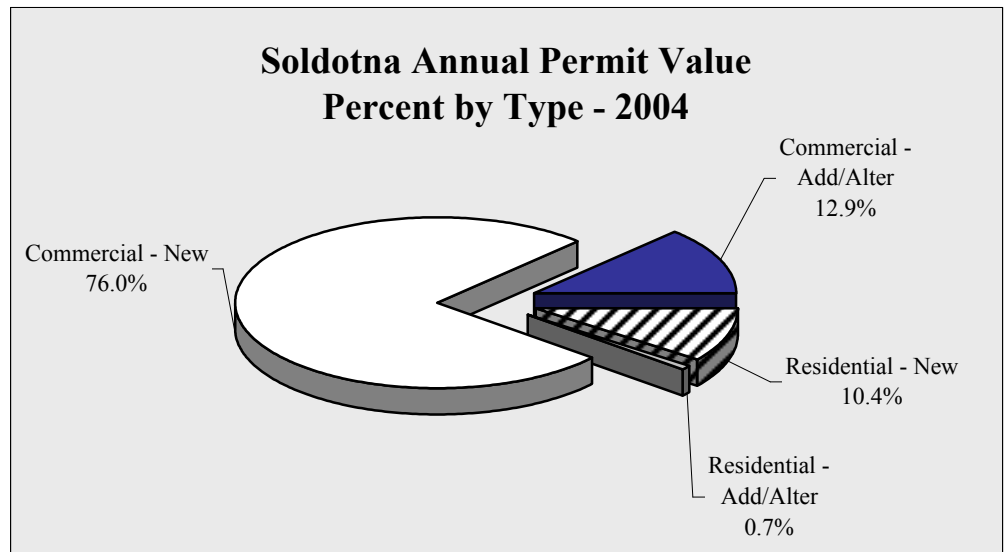

Chart 6.14

Soldotna Construction Permitting

Soldotna Annual Permit Volume by Type - 1998-2004

	1998	1999	2000	2001	2002	2003	2004	Annual Change
Residential - New	15	19	19	24	24	24	19	-20.8%
Residential - Add/Alter	16	16	19	23	20	16	17	6.3%
Commercial - New	25	20	18	10	18	16	13	-18.8%
Commercial - Add/Alter	21	22	32	36	29	18	18	0.0%
TOTAL	77	77	88	93	91	74	67	-9.5%
Annual Change		0.0%	14.3%	5.7%	-2.2%	-18.7%	-9.5%	

Table 6.10

Soldotna Annual Permit Volume by Type - 1986-2004

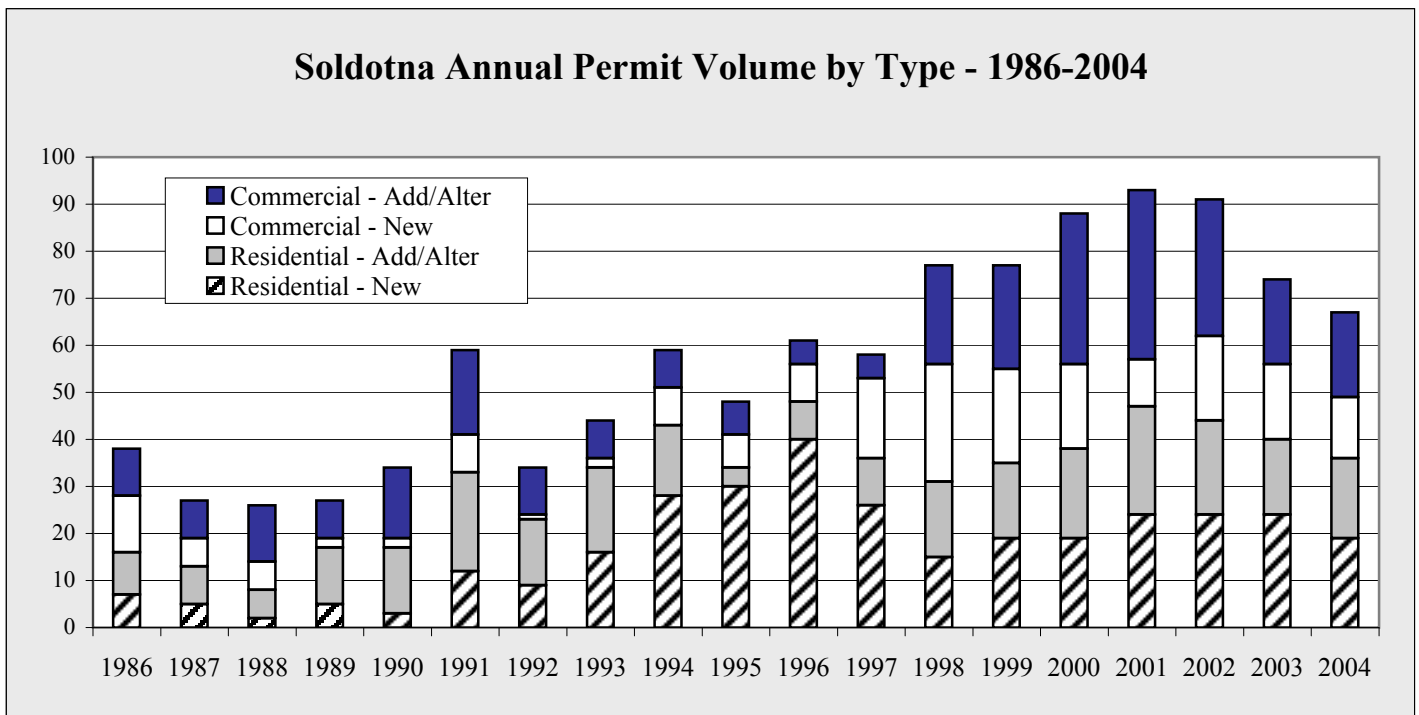

Chart 6.15

Soldotna Permit Volume Percent by Type - 2004

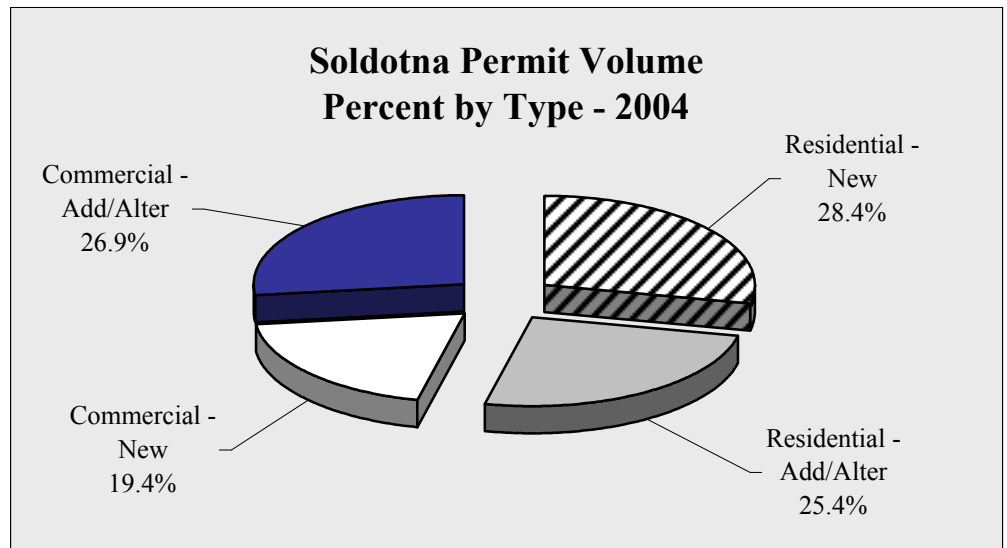

Chart 6.16

Soldotna Construction Permitting

Soldotna Annual Permit Values by Type, Quarter - 1998-2005 - in \$

	1st Quarter	2nd Quarter	3rd Quarter	4th Quarter	Total
1998					
Residential - New	145,000	965,000	1,062,000	175,000	2,347,000
Residential - Add/Alter	0	122,000	103,400	11,660	237,060
Commercial - New	6,552	2,333,400	3,250,713	300,000	5,890,665
Commercial - Add/Alter	78,542	73,000	723,050	272,500	1,147,092
TOTAL	230,094	3,493,400	5,139,163	759,160	9,621,817
1999					
Residential - New	0	1,453,674	1,368,900	225,888	3,048,462
Residential - Add/Alter	54,000	181,361	141,867	0	377,228
Commercial - New	0	2,723,818	2,495,816	281,905	5,501,539
Commercial - Add/Alter	29,696	426,199	119,996	2,000	577,891
TOTAL	83,696	4,785,052	4,126,579	509,793	9,505,120
2000					
Residential - New	373,929	1,520,491	543,930	270,668	2,709,018
Residential - Add/Alter	0	224,674	101,065	39,500	365,239
Commercial - New	434,273	1,583,642	935,665	970,484	3,924,064
Commercial - Add/Alter	270,000	680,549	96,250	122,300	1,169,099
TOTAL	1,078,202	4,009,356	1,676,910	1,402,952	8,167,420
2001					
Residential - New	0	2,363,001	1,510,852	0	3,873,853
Residential - Add/Alter	105,160	151,039	50,148	51,148	357,495
Commercial - New	2,658,578	0	630,244	0	3,288,822
Commercial - Add/Alter	287,480	717,150	318,672	111,500	1,434,802
TOTAL	3,051,218	3,231,190	2,509,916	162,648	8,954,972
2002					
Residential - New	240,849	2,075,293	689,202	176,000	3,181,344
Residential - Add/Alter	86,935	339,286	317,466	11,500	755,187
Commercial - New	714,806	2,601,575	1,080,678	0	4,397,059
Commercial - Add/Alter	163,000	1,987,304	610,000	70,000	2,830,304
TOTAL	1,205,590	7,003,458	2,697,346	257,500	11,163,894
2003					
Residential - New	0	1,899,354	648,388	526,191	3,073,933
Residential - Add/Alter	57,827	130,080	70,722	5,000	263,629
Commercial - New	0	2,116,490	1,371,200	281,491	3,769,181
Commercial - Add/Alter	369,191	88,000	328,000	60,363	845,554
TOTAL	427,018	4,233,924	2,418,310	873,045	7,952,297
2004					
Residential - New	539,297	1,777,087	1,270,100	294,860	3,881,344
Residential - Add/Alter	0	74,809	145,721	57,454	277,984
Commercial - New	4,465,026	1,366,297	21,996,101	501,601	28,329,025
Commercial - Add/Alter	60,000	530,380	368,193	3,850,000	4,808,573
TOTAL	5,064,323	3,748,573	23,780,115	4,703,915	37,296,926
2005					
	Year to Date				
Residential - New	720,956				720,956
Residential - Add/Alter	261,630				261,630
Commercial - New	195,000				195,000
Commercial - Add/Alter	243,969				243,969
TOTAL	1,421,555				1,421,555

Table 6.11

Soldotna Construction Permitting

Soldotna Annual Permit Volume by Type, Quarter - 1998-2005

	1st Quarter	2nd Quarter	3rd Quarter	4th Quarter	Total
1998					
Residential - New	1	6	7	1	15
Residential - Add/Alter	0	6	5	5	16
Commercial - New	2	11	10	2	25
Commercial - Add/Alter	5	4	6	6	21
TOTAL	8	27	28	14	77
1999					
Residential - New	0	10	7	2	19
Residential - Add/Alter	4	8	4	0	16
Commercial - New	0	8	6	6	20
Commercial - Add/Alter	6	9	6	1	22
TOTAL	10	35	23	9	77
2000					
Residential - New	2	10	5	2	19
Residential - Add/Alter	0	9	7	3	19
Commercial - New	1	3	7	7	18
Commercial - Add/Alter	5	12	7	8	32
TOTAL	8	34	26	20	88
2001					
Residential - New	0	14	10	0	24
Residential - Add/Alter	3	10	6	4	23
Commercial - New	3	0	7	0	10
Commercial - Add/Alter	4	13	12	7	36
TOTAL	10	37	35	11	93
2002					
Residential - New	1	17	5	1	24
Residential - Add/Alter	2	6	10	2	20
Commercial - New	4	9	5	0	18
Commercial - Add/Alter	4	19	5	1	29
TOTAL	11	51	25	4	91
2003					
Residential - New	0	15	4	5	24
Residential - Add/Alter	3	8	4	1	16
Commercial - New	0	6	8	2	16
Commercial - Add/Alter	3	7	3	5	18
TOTAL	6	36	19	13	74
2004					
Residential - New	2	9	7	1	19
Residential - Add/Alter	0	8	6	3	17
Commercial - New	4	3	4	2	13
Commercial - Add/Alter	3	6	7	2	18
TOTAL	9	26	24	8	67
2005					
	Year to Date				
Residential - New	4				4
Residential - Add/Alter	3				3
Commercial - New	2				2
Commercial - Add/Alter	7				7
TOTAL	16				16

Table 6.12

Soldotna Cost of Food Survey

Cost of food data is collected by the University of Alaska, Fairbanks Cooperative Extension. Each quarter the Cooperative Extension surveys up to three grocers in communities throughout the state to determine the cost of food for one week. Specific guidelines are presented to the surveyors regarding item size and sale price for 104 items. It has been determined that separation of Kenai and Soldotna data would be meaningless so data presented relates to both communities.

SOLDOTNA/KENAI										
	March 1997	March 1998	March 1999	March 2000	March 2001	March 2002	March 2003	March 2004	March 2005	Annual Change
Sales Tax (in percent)	5.0	5.0	5.0	5.0	5.0	5.0	5.0	5.0	5.0	
Percent of Food Unavailable	0.0	0.0	0.0	1.0	1.0	0.0	1.0	0.0	0.0	
Child, 1 year	16.40	15.88	16.63	16.66	16.81	17.05	18.11	19.17	19.05	-0.6%
Child, 2 years	0.00	0.00	0.00	0.00	0.00	17.05	18.11	18.90	18.87	-0.2%
Children 3-5 years of age	22.18	17.35	18.20	14.67	18.42	18.72	19.87	20.76	20.84	0.4%
Children 6-8 years of age	23.81	22.95	24.24	18.14	24.53	24.96	26.55	28.02	27.93	-0.3%
Children 9-11 years of age	27.03	26.15	27.48	27.51	27.84	28.29	30.07	31.46	31.40	-0.2%
Males 12-14 years of age	30.55	29.51	30.98	31.07	31.50	31.95	33.94	35.44	35.52	0.2%
Males 15-19 years of age	31.47	30.38	31.86	32.03	32.52	33.03	34.90	36.50	36.57	0.2%
Males 20-50 years of age	31.32	30.20	31.60	31.77	32.42	33.03	34.99	36.58	36.65	0.2%
Males 51 and older	29.88	28.91	30.11	30.29	30.82	31.45	33.32	34.91	34.96	0.1%
Females 12-19 years of age	26.35	25.46	26.69	26.82	27.17	27.63	29.19	30.67	30.73	0.2%
Females 20-50 years of age	27.47	26.58	27.57	27.77	28.35	28.88	30.60	31.99	31.96	-0.1%
Females 51 and older	26.68	25.72	26.78	26.99	27.58	28.13	29.72	31.02	31.09	0.2%
Family of 2, 20-50 years of age	62.72	62.48	65.12	65.53	66.84	68.09	72.18	75.43	75.48	0.1%
Family of 2, 51 years and older	62.22	60.06	62.58	63.01	64.24	65.54	69.37	72.51	72.64	0.2%
Family of 4, children 1-5 years	93.13	90.01	94.00	94.52	95.99	97.69	103.57	108.24	108.31	0.1%
Family of 4, children 6-11 years	109.63	105.89	110.89	111.36	113.14	115.16	122.21	128.06	127.94	-0.1%
Electricity, 1000 kWh	111.00	119.89	120.65	119.36	111.90	122.09	124.36	100.82	115.35	14.4%
Gasoline, auto, 55 gal	76.95	74.75	67.32	81.95	94.05	79.45	100.10	100.65	120.45	19.7%
Lumber, 2X4X8'	3.87	3.34	3.50	3.60	2.96	3.13	3.28	3.04	3.29	8.2%
Propane, 100 lb. refill	39.48	39.48	34.93	42.48	49.56	43.42	54.04	49.10	56.64	15.4%
Sewer & Water, monthly	41.58	41.29	0.00	0.00	0.00	0.00	0.00	0.00	0.00	NA

Table 6.13

Soldotna Cost of Food Survey

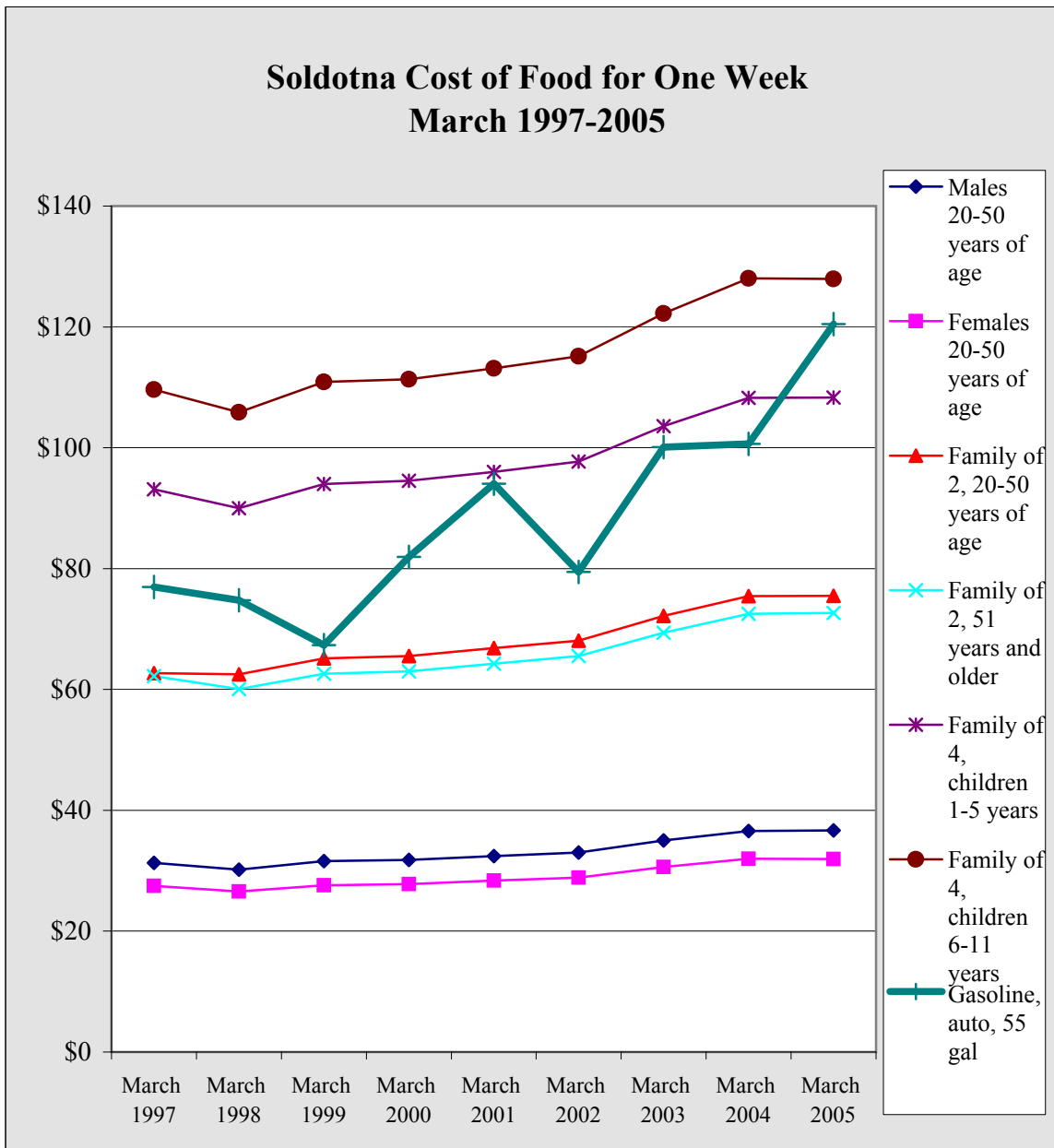

Chart 6.17

Soldotna Population

Soldotna Select Detail - 1990 v 2000

Population					Housing				
	1990	2000	Percent Change	Percent of Total		1990	2000	Percent Change	Percent of Total
Total Population	3,482	3,759	8.0%	100.0%	Total Households	1,284	1,465	14.1%	100.0%
Male	1,727	1,788	3.5%	47.6%	Family Households	903	970	7.4%	66.2%
Female	1,755	1,971	12.3%	52.4%	With Children Under 18		577	NA	39.4%
Under 5 years	330	269	-18.5%	7.2%	Married Couple Family	674	711	5.5%	48.5%
5 to 9 years	354	331	-6.5%	8.8%	With Own Children Under 18		376	NA	25.7%
10 to 14 years	306	366	19.6%	9.7%	Female Householder, no husband present		201	NA	13.7%
15 to 19 years	281	331	17.8%	8.8%	With Own Children Under 18		159	NA	10.9%
20 to 24 years	197	167	-15.2%	4.4%	Average Household Size	2.69	2.53	NA	0.2%
25 to 34 years	627	420	-33.0%	11.2%	Average Family Size		3.13	NA	0.2%
35 to 44 years	675	629	-6.8%	16.7%	Total Housing Units	1,460	1,670	NA	114.0%
45 to 54 years	337	596	76.9%	15.9%	Occupied Housing Units	1,284	1,465	14.1%	100.0%
55 to 59 years	115	176	53.0%	4.7%	Vacant Housing Units	176	205	16.5%	14.0%
60 to 64 years	84	105	25.0%	2.8%	Seasonal, Recreational, Occasional Use		24	145.8%	4.0%
65 to 74 years	131	198	51.1%	5.3%	Owner Vacancy Rate	4.2%	1.9%	NA	NA
75 to 84 years	39	144	269.2%	3.8%	Rental Vacancy Rate	12.3%	15.4%	NA	NA
85 years and over	6	27	350.0%	0.7%	Owner Occupied Units	747	920	23.2%	62.8%
Median Age	29.5	34.9	18.3%	NA	Renter Occupied Units	537	545	1.5%	37.2%
18 Years and Over	1,181	2,475	109.6%	65.8%	Marital Status (over 15)		2,751	NA	NA
Male		1,166	NA	31.0%	Never married		618	NA	22.5%
Female		1,409	NA	37.5%	Married except separated		1,505	NA	54.7%
65 Years and Over	176	369	109.7%	9.8%	Separated		97	NA	3.5%
Male		126	NA	3.4%	Widowed		152	NA	5.5%
Female		243	NA	6.5%	Divorced		379	NA	13.8%
Place of Birth					Disabled, Noninstitutionalized				
Native Born	3,405	3,609	6.0%	96.0%	Population 5 to 20		1,072	NA	100.0%
Born in Alaska		1,432	NA	38.1%	With a Disability		73	NA	6.8%
Born in other state		2,160	NA	57.5%	Population 21 to 64		2,079	NA	100.0%
Foreign Born	51	113	121.6%	3.0%	With a Disability		432	NA	20.8%
Naturalized Citizen		94	NA	2.5%	Percent Employed		54.9%	NA	0.0%
Not a Citizen		19	NA	0.5%	Without a Disability		1,647	NA	79.2%
Veteran Status - (over 18)					Percent Employed		77.7%	NA	0.0%
Civilian veterans	400	396	NA	15.7%	Income in 1999 - Families				
Educational Attainment							Total	980	
Population 25 years and over				2,249	Less than \$10,000	41	34	-17.1%	3.5%
Less than 9th grade	39	59	51.3%	2.6%	\$10,000 - \$14,999	46	42	-8.7%	4.3%
9th-12th, no diploma	116	219	88.8%	9.7%	\$15,000 - \$24,999	160	104	-35.0%	10.6%
High School Diploma	730	790	8.2%	35.1%	\$25,000 - \$34,999	60	109	81.7%	11.1%
College, no degree	555	694	25.0%	30.9%	\$35,000 - \$49,999	201	164	-18.4%	16.7%
Associate Degree	147	139	-5.4%	6.2%	\$50,000 - \$74,999	257	216	-16.0%	22.0%
Bachelor's Degree	283	214	-24.4%	9.5%	\$75,000 - \$99,999	115	140	21.7%	14.3%
Graduate, Profess Degree	110	134	21.8%	6.0%	\$100,000 - \$149,999	40	127	217.5%	13.0%
Percent HS Grad	92.2%	87.6%	-5.0%	NA	\$150,000 - \$199,999	0	18	NA	1.8%
Percent Bachelor's +	19.8%	15.5%	-21.7%	NA	\$200,000 or more	NA	26	NA	2.7%
					Median Income - \$	46,667	52,372	12.2%	NA

Table 6.14

KPB Unincorporated Area Sales

KPB Unincorporated 1st Quarter Gross Sales by Industry - 1999-2005 - in \$								
	1999	2000	2001	2002	2003	2004	2005	Annual Change
AFF	352,211	352,282	545,478	447,651	445,085	438,254	465,423	6.2%
Min	34,450,859	18,280,459	27,248,851	32,299,252	18,139,022	37,672,228	37,465,302	-0.5%
Const	10,514,866	12,148,240	21,706,616	24,605,950	22,024,293	15,137,343	21,389,579	41.3%
Manu	19,503,745	19,962,580	41,056,398	14,954,570	31,662,293	21,943,272	5,263,442	-76.0%
TCPU	18,000,772	15,686,890	16,720,929	18,420,972	14,598,070	14,959,439	18,894,611	26.3%
Whole	17,788,353	19,617,188	20,272,119	21,943,141	20,948,522	22,031,868	25,153,252	14.2%
Retail	22,158,531	25,988,141	27,173,506	28,752,133	30,773,844	30,043,965	29,210,862	-2.8%
FIRE	3,147,542	3,038,933	3,268,311	3,214,862	2,801,512	3,743,613	3,153,580	-15.8%
Service	11,530,093	11,590,268	12,558,002	14,742,430	12,971,156	13,197,994	14,061,176	6.5%
Govt	0	0	0	0	0	6,365	13,317	109.2%
Total	137,446,972	126,664,981	170,550,210	159,380,961	154,363,797	159,174,341	155,070,544	-2.6%
Annual Change		-7.8%	34.6%	-6.5%	-3.1%	3.1%	-2.6%	

Table 7.1

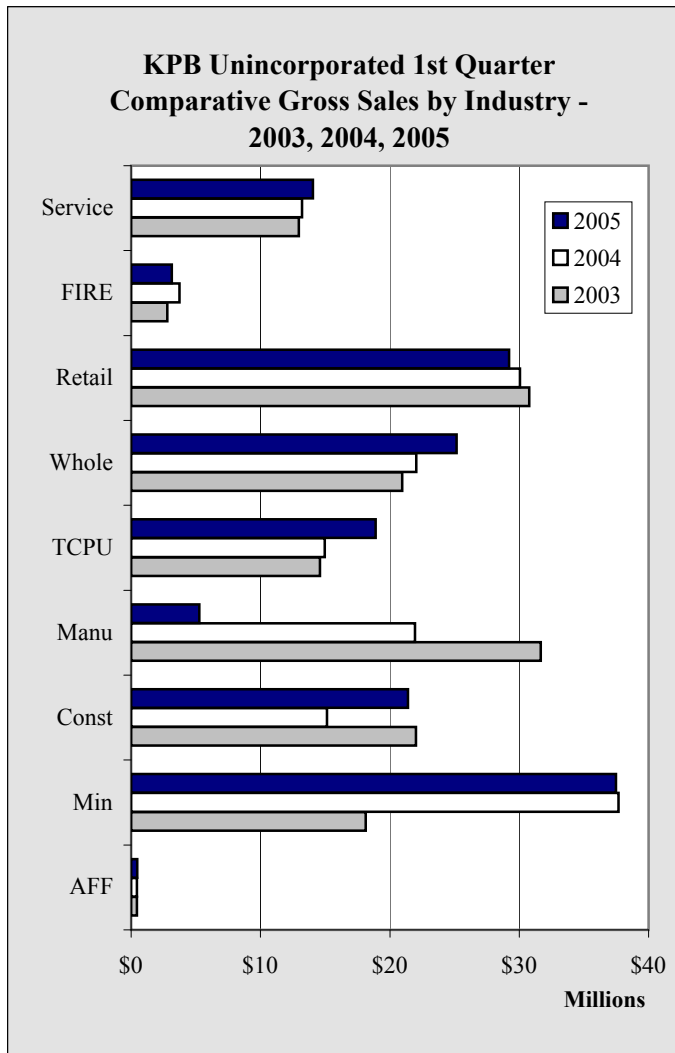

Chart 7.1

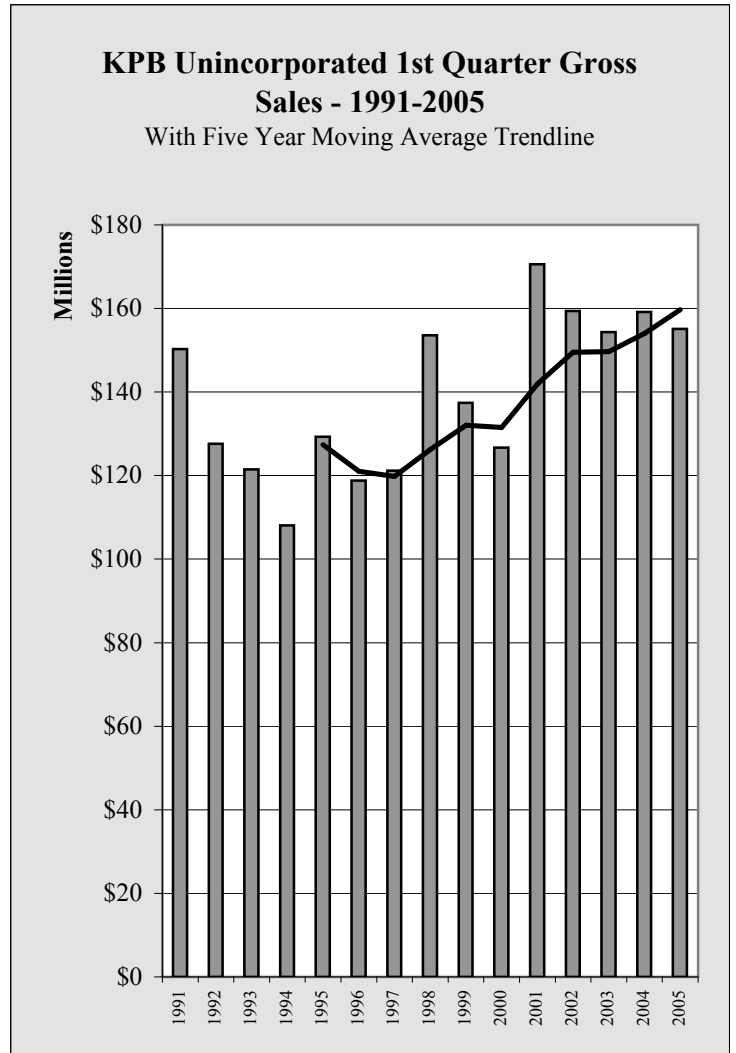

Chart 7.2

KPB Unincorporated Area Sales

KPB Unincorporated 1st Quarter Taxable Sales by Industry - 1999-2005 - in \$

	1999	2000	2001	2002	2003	2004	2005	Annual Change
AFF	250,732	296,108	343,834	396,517	360,151	402,891	419,213	4.1%
Min	756,274	869,838	1,159,787	1,424,074	1,190,125	977,166	1,011,467	3.5%
Const	1,016,102	946,521	1,078,729	1,132,055	1,144,439	1,180,160	1,120,998	-5.0%
Manu	389,123	347,573	408,113	396,651	355,143	367,901	383,507	4.2%
TCPU	10,204,126	9,905,033	10,437,988	12,140,823	9,916,712	10,258,635	12,356,091	20.4%
Whole	2,182,510	2,513,184	2,580,662	2,865,394	2,773,715	3,328,186	3,214,145	-3.4%
Retail	13,321,220	14,473,470	15,269,638	16,309,155	16,136,823	16,098,232	14,950,250	-7.1%
FIRE	1,284,648	1,230,682	1,327,960	1,506,676	1,452,777	1,481,302	1,338,749	-9.6%
Service	4,943,733	5,113,952	5,448,548	5,633,539	5,055,788	4,980,414	4,768,229	-4.3%
Govt	0	0	0	0	0	6,300	13,317	111.4%
Total	34,348,468	35,696,361	38,055,259	41,804,884	38,385,673	39,081,187	39,575,966	1.3%
Annual Change		3.9%	6.6%	9.9%	-8.2%	1.8%	1.3%	

Table 7.2

KPB Unincorporated 1st Quarter Comparative Taxable Sales by Industry 2003, 2004, 2005

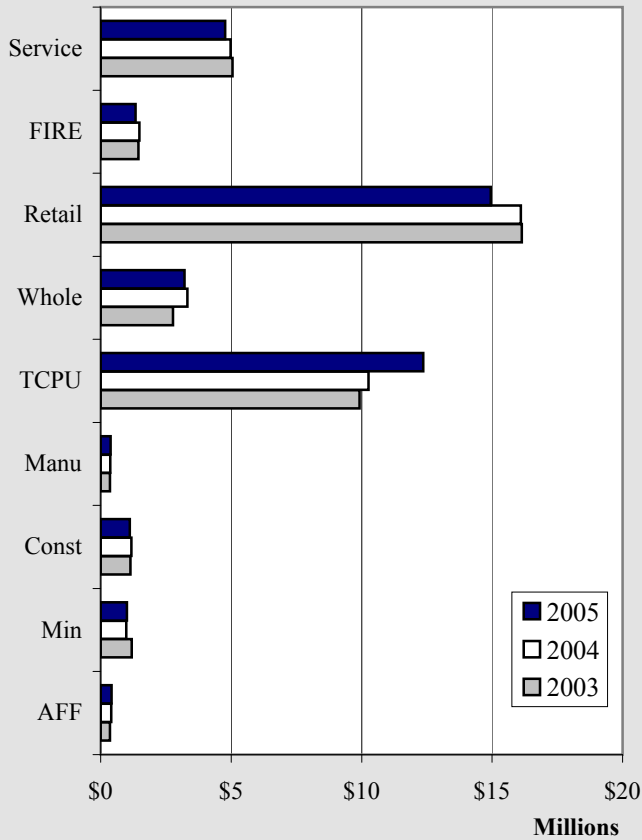

Chart 7.3

KPB Unincorporated 1st Quarter Taxable Sales - 1991-2005 With Five Year Moving Average Trendline

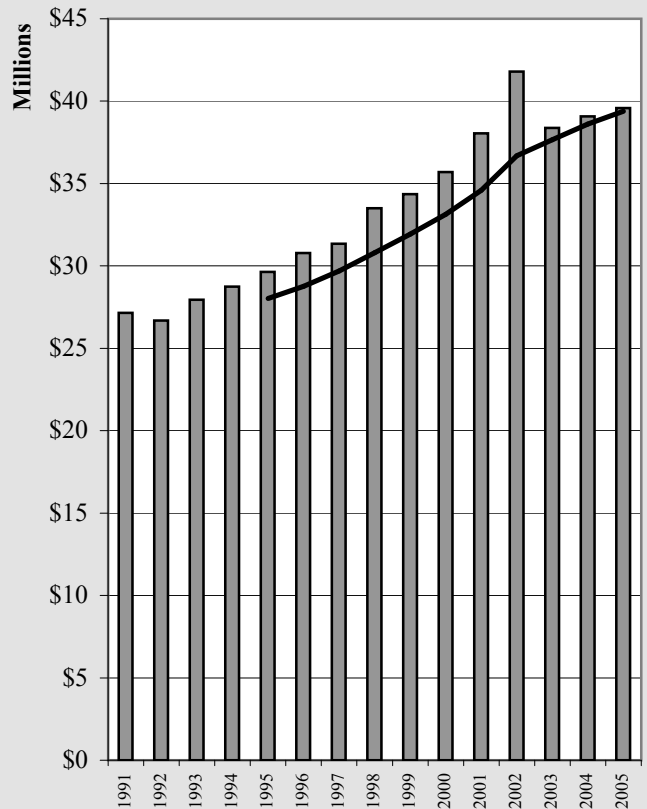

Chart 7.4

KPB Unincorporated Area Sales

KPB Unincorporated Annual Gross Sales by Industry - 1998-2004 - in \$								
	1998	1999	2000	2001	2002	2003	2004	Annual Change
AFF	6,119,386	2,812,823	2,875,629	3,242,403	4,090,590	4,814,409	5,857,634	21.7%
Min	187,521,559	113,163,554	115,625,431	123,091,789	108,808,400	101,004,267	155,698,225	54.2%
Const	88,142,507	87,808,495	88,853,048	136,499,774	131,261,695	133,897,211	130,443,722	-2.6%
Manu	112,671,455	132,512,994	85,638,574	250,593,511	164,076,655	159,471,272	143,966,955	-9.7%
TCPU	73,567,609	78,647,818	66,837,538	77,388,092	73,138,015	63,786,231	78,102,991	22.4%
Whole	101,466,620	91,041,042	101,310,365	104,710,505	108,334,825	115,986,698	119,012,626	2.6%
Retail	128,963,750	128,644,968	138,967,225	153,029,767	155,130,975	166,755,991	167,783,923	0.6%
FIRE	15,909,441	15,194,140	13,106,195	15,680,221	14,436,076	16,408,311	19,316,392	17.7%
Service	78,651,481	83,322,595	95,090,680	100,412,737	102,659,177	98,547,914	113,281,658	15.0%
Govt	6,585	0	0	0	0	0	13,732	NA
Total	793,020,393	733,148,429	708,304,685	964,648,799	861,936,408	860,672,304	933,477,858	8.5%
Annual Change		-7.5%	-3.4%	36.2%	-10.6%	-0.1%	8.5%	

Table 7.3

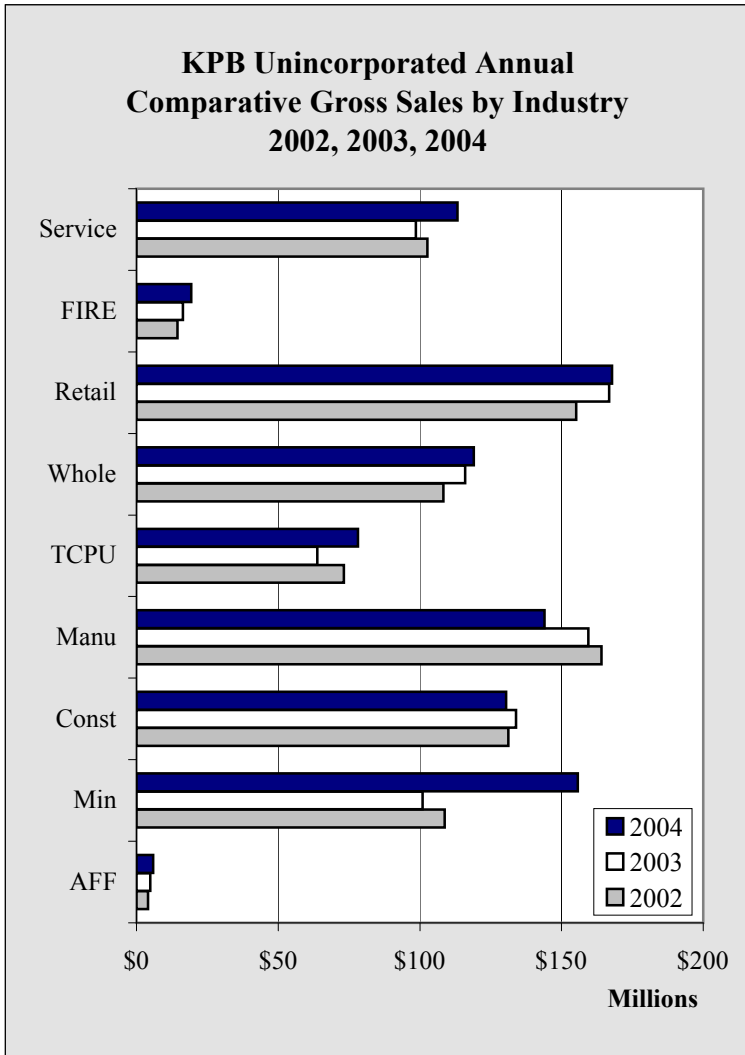

Chart 7.5

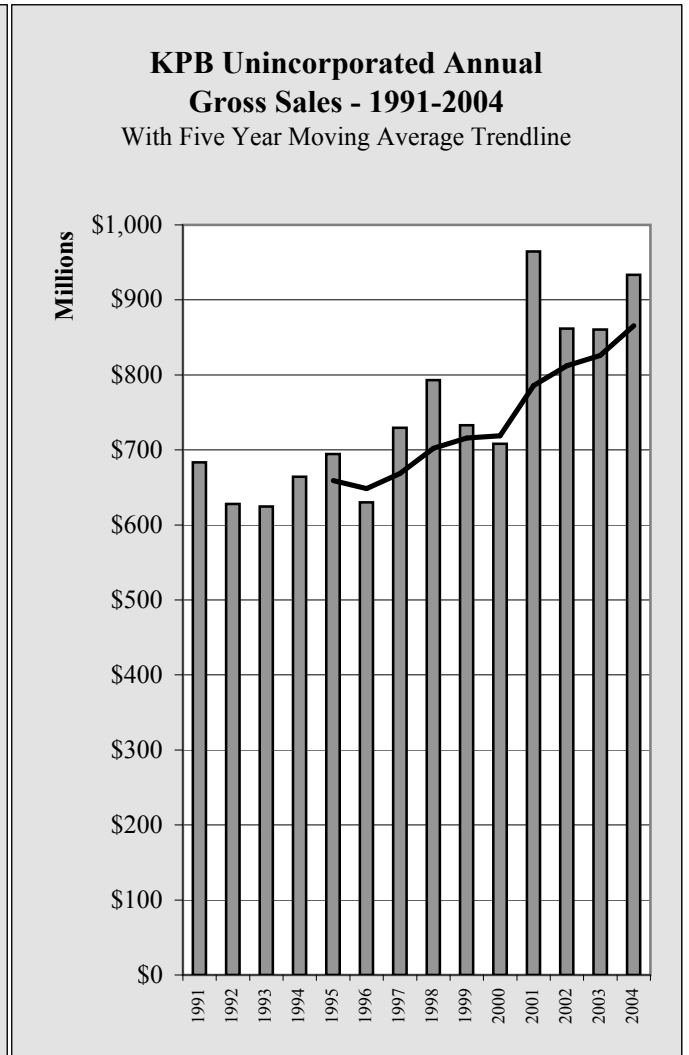

Chart 7.6

KPB Unincorporated Area Sales

KPB Unincorporated Annual Taxable Sales by Industry - 1998-2004 - in \$								
	1998	1999	2000	2001	2002	2003	2004	Annual Change
AFF	1,722,929	1,738,057	1,945,844	2,016,782	2,152,460	2,281,300	2,540,907	11.4%
Min	5,144,815	3,724,685	4,434,095	5,598,954	5,598,990	4,655,675	5,218,907	12.1%
Const	5,738,513	5,621,785	5,735,340	6,115,447	6,566,858	6,601,200	6,787,853	2.8%
Manu	3,388,424	3,021,658	3,084,591	3,041,030	2,944,959	2,626,320	2,872,144	9.4%
TCPU	35,992,074	39,160,283	39,092,526	42,147,135	41,606,993	37,098,365	40,099,801	8.1%
Whole	8,733,322	9,868,388	11,100,421	11,675,046	11,425,901	12,058,985	12,952,451	7.4%
Retail	72,533,481	75,119,590	80,838,970	85,853,411	86,150,313	89,695,084	88,824,823	-1.0%
FIRE	5,494,477	5,585,421	5,678,461	6,363,047	6,509,160	7,017,830	6,664,257	-5.0%
Service	40,794,714	43,554,212	47,432,032	48,734,123	47,390,646	47,504,072	52,072,433	9.6%
Govt	6,585	0	0	0	0	0	13,667	NA
Total	179,549,334	187,394,079	199,342,280	211,544,975	210,346,280	209,538,831	218,047,243	4.1%
Annual Change		4.4%	6.4%	6.1%	-0.6%	-0.4%	4.1%	

Table 7.4

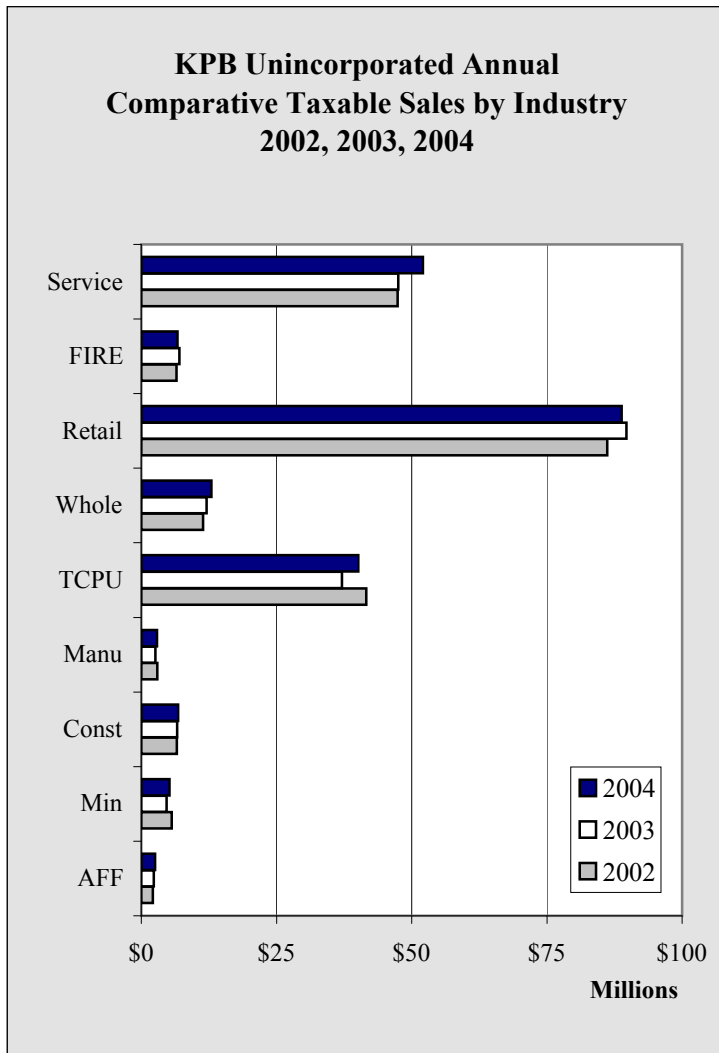

Chart 7.7

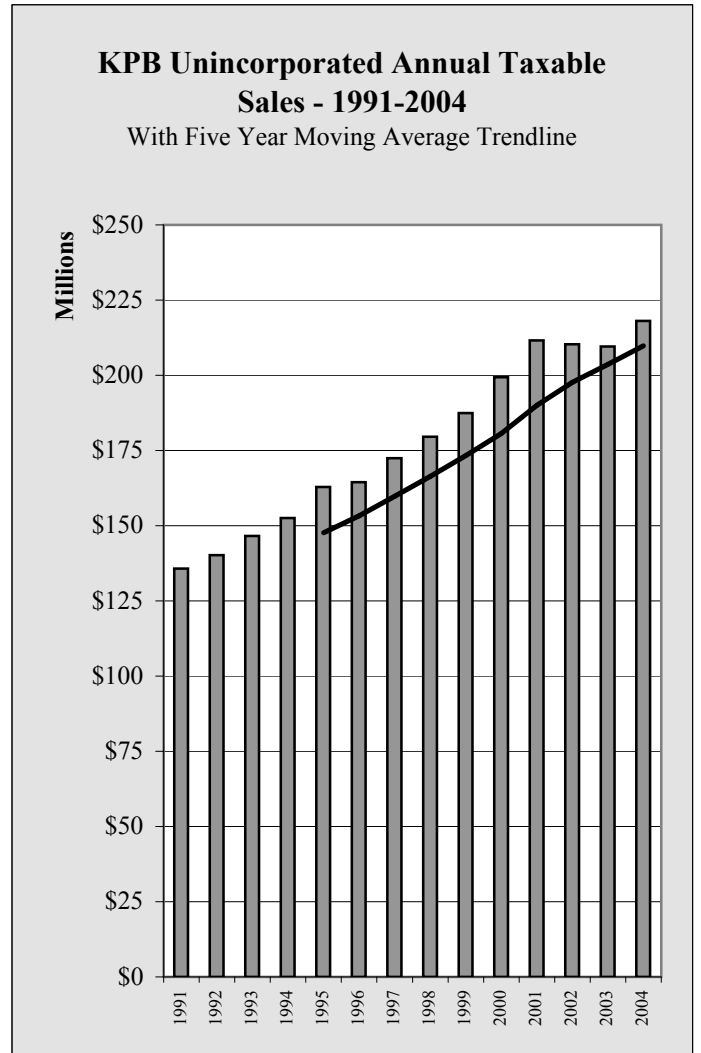

Chart 7.8

KPB Unincorporated Area Sales

KPB Unincorporated Gross Sales by Industry by Quarter - 2002-2005 - in \$					
	1st Quarter	2nd Quarter	3rd Quarter	4th Quarter	Total
2002					
AFF	447,651	1,142,492	1,430,097	1,070,350	4,090,590
Min	32,299,252	29,103,164	25,287,979	22,118,005	108,808,400
Const	24,605,950	30,778,098	40,528,297	35,349,350	131,261,695
Manu	14,954,570	34,871,253	44,941,727	69,309,105	164,076,655
TCPU	18,420,972	18,167,731	21,630,289	14,919,023	73,138,015
Whole	21,943,141	28,469,316	31,837,444	26,084,924	108,334,825
Retail	28,752,133	40,486,870	50,013,715	35,878,257	155,130,975
FIRE	3,214,862	3,704,383	3,878,053	3,638,778	14,436,076
Service	14,742,430	28,996,481	43,193,240	15,727,026	102,659,177
Govt	0	0	0	0	0
Total	159,380,961	215,719,788	262,740,841	224,094,818	861,936,408
2003					
AFF	445,085	2,042,231	1,578,920	748,173	4,814,409
Min	18,139,022	24,039,296	28,701,184	30,124,765	101,004,267
Const	22,024,293	35,948,201	44,783,625	31,141,092	133,897,211
Manu	31,662,293	22,050,431	53,343,537	52,415,011	159,471,272
TCPU	14,598,070	15,634,861	18,568,068	14,985,232	63,786,231
Whole	20,948,522	29,652,374	37,077,443	28,308,359	115,986,698
Retail	30,773,844	46,326,072	52,432,838	37,223,237	166,755,991
FIRE	2,801,512	4,574,602	5,140,046	3,892,151	16,408,311
Service	12,971,156	27,700,199	42,294,496	15,582,063	98,547,914
Govt	0	0	0	0	0
Total	154,363,797	207,968,267	283,920,157	214,420,083	860,672,304
2004					
AFF	438,254	1,256,193	1,632,207	2,530,980	5,857,634
Min	37,672,228	29,692,204	36,588,670	51,745,123	155,698,225
Const	15,137,343	22,803,329	37,227,466	55,275,584	130,443,722
Manu	21,943,272	7,606,427	87,311,541	27,105,715	143,966,955
TCPU	14,959,439	16,722,028	20,217,590	26,203,934	78,102,991
Whole	22,031,868	28,462,396	36,327,578	32,190,784	119,012,626
Retail	30,043,965	45,764,761	54,228,470	37,746,727	167,783,923
FIRE	3,743,613	3,934,012	4,830,935	6,807,832	19,316,392
Service	13,197,994	30,871,120	48,051,651	21,160,893	113,281,658
Govt	6,365	0	6,304	1,063	13,732
Total	159,174,341	187,112,470	326,422,412	260,768,635	933,477,858
2005					
					Year To Date
AFF	465,423				465,423
Min	37,465,302				37,465,302
Const	21,389,579				21,389,579
Manu	5,263,442				5,263,442
TCPU	18,894,611				18,894,611
Whole	25,153,252				25,153,252
Retail	29,210,862				29,210,862
FIRE	3,153,580				3,153,580
Service	14,061,176				14,061,176
Govt	13,317				13,317
Total	155,070,544				155,070,544

Table 7.5

KPB Unincorporated Area Sales

KPB Unincorporated Taxable Sales by Industry by Quarter - 2002-2005 - in \$					
	1st Quarter	2nd Quarter	3rd Quarter	4th Quarter	Total
2002					
AFF	396,517	780,587	570,742	404,614	2,152,460
Min	1,424,074	1,417,403	1,489,849	1,267,664	5,598,990
Const	1,132,055	1,657,737	2,141,282	1,635,784	6,566,858
Manu	396,651	881,441	1,202,450	464,417	2,944,959
TCPU	12,140,823	11,314,077	9,075,340	9,076,753	41,606,993
Whole	2,865,394	2,743,971	2,958,254	2,858,282	11,425,901
Retail	16,309,155	23,266,764	27,810,124	18,764,270	86,150,313
FIRE	1,506,676	1,626,536	1,941,804	1,434,144	6,509,160
Service	5,633,539	13,671,993	21,829,387	6,255,727	47,390,646
Govt	0	0	0	0	0
Total	41,804,884	57,360,509	69,019,232	42,161,655	210,346,280
2003					
AFF	360,151	859,055	635,120	426,974	2,281,300
Min	1,190,125	1,114,615	1,252,874	1,098,061	4,655,675
Const	1,144,439	1,889,809	2,022,587	1,544,365	6,601,200
Manu	355,143	792,161	968,694	510,322	2,626,320
TCPU	9,916,712	9,184,673	8,687,138	9,309,842	37,098,365
Whole	2,773,715	2,930,861	3,197,783	3,156,626	12,058,985
Retail	16,136,823	25,345,609	28,911,497	19,301,155	89,695,084
FIRE	1,452,777	1,841,058	2,240,741	1,483,254	7,017,830
Service	5,055,788	14,212,739	22,072,245	6,163,300	47,504,072
Govt	0	0	0	0	0
Total	38,385,673	58,170,580	69,988,679	42,993,899	209,538,831
2004					
AFF	402,891	915,588	748,068	474,360	2,540,907
Min	977,166	1,018,997	1,829,645	1,393,099	5,218,907
Const	1,180,160	1,735,881	2,118,052	1,753,760	6,787,853
Manu	367,901	785,263	1,215,828	503,152	2,872,144
TCPU	10,258,635	8,908,793	10,037,127	10,895,246	40,099,801
Whole	3,328,186	2,862,301	3,238,122	3,523,842	12,952,451
Retail	16,098,232	24,700,574	29,192,610	18,833,407	88,824,823
FIRE	1,481,302	1,680,137	1,946,397	1,556,421	6,664,257
Service	4,980,414	15,603,491	25,071,817	6,416,711	52,072,433
Govt	6,300	0	6,304	1,063	13,667
Total	39,081,187	58,211,025	75,403,970	45,351,061	218,047,243
2005					
					Year To Date
AFF	419,213				419,213
Min	1,011,467				1,011,467
Const	1,120,998				1,120,998
Manu	383,507				383,507
TCPU	12,356,091				12,356,091
Whole	3,214,145				3,214,145
Retail	14,950,250				14,950,250
FIRE	1,338,749				1,338,749
Service	4,768,229				4,768,229
Govt	13,317				13,317
Total	39,575,966				39,575,966

Table 7.6

KPB Local Officials Directory

Officials of the various governing bodies within the Kenai Peninsula Borough are listed on the following pages.

The officials listed are those who held office at the time of printing of the report. Annual elections for public officials are held each October. For information regarding current public officials, check the appropriate website.

Kenai Peninsula Borough – <http://www.borough.kenai.ak.us/>

Kenai Peninsula Borough School District – <http://www.kpbsd.k12.ak.us/>

City of Homer – <http://www.ci.homer.ak.us/>

City of Kenai – <http://www.ci.kenai.ak.us/>

City of Seldovia – <http://www.xyz.net/~seldovia/>

City of Seward – <http://www.cityofseward.net/>

City of Soldotna – <http://www.ci.soldotna.ak.us/>

KPB Local Officials Directory

Kenai Peninsula Borough Mayors

Kenai Peninsula Borough

Mayor Dale Bagley
144 North Binkley
Soldotna, AK 99669
907-262-4441

City of Homer Mayor Jim Hornady
491 East Pioneer Ave.
Homer, AK 99603
907-235-8121

City of Kachemak Mayor Philemon Morris
PO Box 598
Homer, AK 99603
907-235-8897

City of Kenai Mayor Pat Porter
210 Fidalgo Street, Suite 200
Kenai, AK 99611
907-283-7535

City of Seldovia Mayor Dick Wyland
Drawer B
Seldovia, AK 99663
907-234-7643

City of Seward Mayor Vanta Shafer
PO Box 167
Seward, AK 99664
907-224-4046

City of Soldotna Mayor Dave Carey
177 North Birch
Soldotna, AK 99669
907-262-9107

**KENAI PENINSULA BOROUGH
PLANNING COMMISSION MEMBERS**

2005

Member	Contact Information	Term Expires
CHAIRMAN Philip Bryson P.O. Box 1041 Kenai, Alaska 99611-1041	283-4672 work 283-4428 home	Kenai City Term Expires July 31, 2007
VICE CHAIRMAN Tom Clark P.O. Box 962 Anchor Point, Alaska 99556-0962	235-2887 home	Anchor Point/Ninilchik Term Expires July 31, 2007
PARLIAMENTARIAN Patricia Hartley 144 North Binkley Soldotna, Alaska 99669	714-2215 - work	Planning Administrative Assistant
Dick Troeger 372 Lupine Street Soldotna, Alaska 99669	262-5387 - home	Soldotna City Term Expires July 31, 2005
Dr. Rick Foster P.O. Box 3328 Homer, AK 99603-3328	235-9100 - home	Homer City Term Expires July 31, 2007
Mari Anne Gross 57485 Clover Avenue Homer, Alaska 99603	235-7330 - home	Southwest Borough Term Expires July 31, 2005
Lynn Hohl P.O. Box 333 Seward, Alaska 99664-0333	224-7300 - home	Seward City Term Expires July 31, 2005
William Hutchinson P.O. Box 2585 Soldotna, Alaska 99669-2585	262-5256 - home	Ridgeway Term Expires July 31, 2007
James Isham P.O. Box 51 Soldotna, Alaska 99669-0051	262-9200 - home	Sterling Term Expires July 31, 2006
Brent Johnson 20773 Porcupine Lane Clam Gulch, Alaska 99568-9713	262-4763 - home	Kasilof/Clam Gulch Term Expires July 31, 2006
Blair Martin P.O. Box 1776 Soldotna, Alaska 99669-1776	283-5227 - home	Kalifornsky Beach Term Expires July 31, 2006
Mark Massion P.O. Box 203 Seldovia, Alaska 99663-0278	234-7575 - home	Seldovia City Term Expires July 31, 2006
Todd Petersen P.O. Box 651 Seward, Alaska 99664-0651	288-5050 - home 224-3350 - work 224-2388 - work fax	East Peninsula Term Expires July 31, 2007
Ray Tauriainen P.O. Box 8678 Nikiski, Alaska 99635-8678	776-8885 - home	Northwest Borough Term Expires July 31, 2005

Email address for the Planning Commission: planning@borough.kenai.ak.us
Fax Number for the Planning Commission: 907-262-8618

KPB Local Officials Directory

Kenai Peninsula Borough School District

148 North Binkley Street
Soldotna, AK 99669
907-262-5846

<u>Board of Education</u>			
Lorraine Crawford, President	36615 Chinula Drive Kenai, AK 99611	907-283-9271	Term Expires 2007
Sandra Wassilie, Vice President	PO Box 1576 Seward, AK 99664	907-224-3950	Term Expires 2007
Debra Mullins, Clerk	53630 Redoubt Drive Kenai, AK 99611	907-776-5250	Term Expires 2005
Margaret Gilman, Treasurer	216 Susianna St. Kenai, AK 99611	907-283-0860	Term Expires 2006
Marty Anderson	P.O. Box 1388 Sterling, AK 99672	907-260-7500	Term Expires 2006
Nels Anderson, MD	303 Diane Lane Soldotna, AK 99669	907-262-3280	Term Expires 2005
Debbie Brown	P.O. Box 592 Kasilof, AK 99610	907-262-4551	Term Expires 2005
Deborah Germano	P.O. Box 1511 Homer, AK 99603	907-235-2538	Term Expires 2006
Sunni Hilts	P.O. Box 144 Seldovia, AK 99663	907-234-7692	Term Expires 2007
Student Representative DJ Tyson	Kenai Central High School 9853 Kenai Spur Hwy Kenai, AK 99611		Term Expires 2005

<u>Administration</u>	
Dr. Donna Peterson, Superintendent of Schools	
Sam Stewart, Assistant Superintendent	
Gary Whiteley, Assistant Superintendent of Instruction	
Melody Douglas, Chief Financial Officer	
Tim Peterson, Director of Human Resources	

KPB Local Officials Directory

Kenai Peninsula Borough Department Directors

Switchboard	262-4441
Assessing	Shane Horan
Capital Projects	Rob Robson
Clerk	Linda Murphy
Finance	Scott Holt
Legal	Colette Thompson
Maintenance	Dave Tressler
Resource Planning	Max Best
Road Maintenance	Gary Davis
Solid Waste	Cathy Mayer

Kenai Peninsula Borough Economic Development Agencies

KPB Community & Economic Development Division - CEDD

Jack Brown – Business Manager
43335 Kalifornsky Beach Road, Suite 16
Soldotna, AK 99669
907-714-2336

KP Economic Development District - EDD

14790 Kenai Spur Highway, Ste. 106A
Kenai, AK 99611
907-283-3335

Kenai Peninsula Tourism Marketing Council

14790 Kenai Spur Highway, Ste. 103A
Kenai, AK 99611
907-262-5229

KP Resource Conservation and Development, Inc.

Trading Bay Plaza, Suite 150
PO Box 800, Kenai, AK 99611
907-283-7493