



KENAI PENINSULA BOROUGH
QUARTERLY REPORT
OF KEY ECONOMIC INDICATORS

For Fiscal Quarter Ending June 30, 2009
Published October 2009

David R. Carey
Borough Mayor

Compiled and Produced By
John Janik, Economic Analyst
144 North Binkley Street
Soldotna, Alaska 99669
Phone – 907-714-2337

See this document on the web – <http://www.borough.kenai.ak.us>
Using the 'Economic Development' link, Select 'Publications'

Contents

Page #

Introduction-----	2
Executive Summary-----	4
Kenai Peninsula Borough	
Sales – KPB Finance Department-----	17
Construction – Cities of Homer, Kenai, Seldovia, Seward and Soldotna -----	35
Employment – State of Alaska Department of Labor & Workforce Development---	46
Demographics – U.S. Census Bureau, AK Dept of Labor & Workforce Dev. ----	48
Homer	
Sales – KPB Finance Department-----	55
Construction – City of Homer -----	65
Kenai	
Sales – KPB Finance Department-----	71
Construction – City of Kenai -----	81
Seldovia	
Sales – KPB Finance Department-----	87
Construction – City of Seldovia -----	97
Seward	
Sales – KPB Finance Department-----	103
Construction – City of Seward-----	113
Soldotna	
Sales – KPB Finance Department-----	119
Construction – City of Soldotna -----	129
Other	
Sales – KPB Finance Department-----	135
Directory of Local Officials-----	145

Data Sources are listed in each subsection.

Introduction

Kenai Peninsula Borough (KPB) staff develops quarterly reports presenting regional economic data for use by businesses, agencies, and other entities to aid in planning and management decisions.

The publication is divided into eight sections: Kenai Peninsula Borough, Homer, Kenai, Seldovia, Seward, Soldotna, Other KPB and a Local Officials Directory.

To provide unity within the document, certain conventions are applied:

- In the real estate section, the following abbreviations apply:
 - RN - Residential New
 - RA - Residential Alteration/Addition
 - CN - Commercial New
 - CA - Commercial Alteration/Addition

Public projects are included in the commercial categories while permits issued for signs are not presented in this publication.

Due to concerns of releasing proprietary sales information, lines of business (LOB) have been grouped into fewer categories than presented in recent documents. LOB category abbreviations, and LOB's included in each category are listed below.

PROD	Resource Production	Agriculture, Forestry, Fishing and Hunting Mining - (Includes oil and gas exploration, gravel) Timbering
MFG	Manufacturing	Manufacturing - (Includes oil and gas manufacturing, fish processing)
CONST	Construction	Construction
SALES	Sales	Restaurant, Bar Retail
PROP	Rentals	Rental Commercial Property Rental Residential Property Rental Personal Property Rental Non-residential Properties Trailer Court
TOUR	Tourism	Arts, Entertainment, Recreation Guiding Land* Guiding Water* Accommodation
SERV	Services	Administration, Support, Waste Management, Remediation Educational Services Finance and Insurance Information Other Services Remediation Services Cable Telecommunications
PROF	Professional	Health and Social Services Management of Companies, Enterprises Professional, Scientific, Technical
UTIL	Utilities	Utilities
TRAN	Transport/ Warehouse	Transportation and Warehousing*
WHSL	Wholesale	Wholesale
GOV	Public Administration	Public Administration - (Includes Native Organizations)

* - LOB totals are unstable until our software conversion is complete. This quarter, sales in transportation, guiding by land and guiding by water show marked differences as 2006 and 2007 sales have been updated, but not 2005 and prior.

- Information sources for each section of the publication are listed in the index.
- General information applicable to all sections is provided in the KPB section.
- Percentages of parts may not total 100%, due to rounding.

Information presented assists in decision-making by providing economic and demographic information in graphic, table and text form. Data is used by local and state government officials; local, state and federal agencies; businesses within the KPB and elsewhere; and private citizens.

Data is received from various sources and is subject to change as updates, revisions and corrections are received. The KPB makes no claims to accuracy or completeness of information provided. Only summary information is published. For further detail, contact John Janik, Economic Analyst, Kenai Peninsula Borough, 907-714-2337, or the data source listed in the index.

Reports are available electronically at <http://www.borough.kenai.ak.us>. Select the Economic Analysis link in the left hand column, then Publications. Select the publication of interest.

To add or delete your name to the distribution list that alerts interested parties to the availability of new data, please email jjanik@borough.kenai.ak.us or call 907-714-2337. Be certain to identify yourself and the complete email address to be added or deleted. The distribution list is used for notification of website updates, website availability of quarterly data and the annual *Situations and Prospects* in pdf format, and notification of data corrections. The list will not be used for any purpose other than the three stated above.

Kenai Peninsula Borough staff appreciates contributions from the entities listed below, each of which provided data for this publication:

Alaska Department of Labor and Workforce Development (AK DOLWD)
City of Homer
City of Kenai
City of Seldovia
City of Seward
City of Soldotna
KPB Finance Department, Sales Tax Division

The writer wishes to thank those persons who gave of their time to review this document, finding errors and making suggestions that result in a more professional and accurate document. Those individuals include Sylvia Vinson, KPB Planning Department staff and Tara Janik, KPB resident.

Executive Summary

The recession affecting the remainder of the nation is noticeable during the second quarter of 2009 on the Kenai Peninsula as well, although with a lesser impact. Sales, both gross and taxable are down, as is construction, but the most noticeable is the decrease in tourism.

Taxable sales decreased 14.4% to \$232,113,832 from second quarter 2008 while gross sales decreased 17.6% to \$605,387,922, an amount that may be overcome as late returns are recorded in the system.

KPB construction permit activity was typically slow during the first quarter of 2009 but second quarter activity quickly changed the pace as permit values rose to \$22,164,945. The second quarter 2009 permit value though higher than the first quarter total of \$8,683,120 is well below the unusual 2008 second quarter record of \$42,695,985. However, the second quarter permit values are 4.8% higher than the 2003 through 2007 average of \$21,142,688. A second quarter permit total of 118 while typically and substantially higher than the first quarter total of 29 were still shy of the second quarter 2008 total of 127. Although the second quarter 2008 was a record for permit values, 2005 retains the record for the number of permits at 145.

Unemployment indicators for the second quarter of 2009 were disappointing compared to previous years as well as month for month, when compared to April, May, and June of 2008. The labor force experienced erratic gains with only 63 during April to a high of 1,711 in May, and falling to 1,210 for June. The number of unemployed decreased by 337 from 3,189 to 2,852 in April, and again in May by falling 188 more to 2,664. The decline in the number of persons unemployed reversed during June with an increase of 78 persons unemployed to a monthly total of 2,742. In comparison to the number of persons joining the workforce, the number obtaining employment increased as well. The number of persons employed in April was 22,742 which was an increase of 406 over the March total of 22,336. The peak quarterly increase occurred in May with an additional increase of 1,899 persons obtaining employment. Though smaller in volume, the June increase of 1,135 resulted in the highest year to date employment of 25,776. The unemployment rate fell from 12.5% in March to 11.1% in April. May also experienced a further decrease to 9.8%, while June fell even further to a year to date low of 9.6% which is well above the June 2008 rate of 7.3%. The KPB second quarter average unemployment rate of 10.16% is above both the Alaska average of 8.2%, and the national average of 9.27%.

In Kenai, construction of the new Wal-Mart store is underway, and a new public pavilion is being built on the waterfront in Seward. Road construction across the borough is evident with a focus on bridges, most notably in Ninilchik, Seward, and Kasilof. Resurfacing is also scheduled for later in the summer for the Sterling Highway from Soldotna to South Coho Loop in Kasilof.

Population projections for 2008 has been received with growth across the KPB estimated at 1.1% for the year to a total of 52,990. Homer's population decreased 2.0%, while Kenai increased by 2.3%, and Seward fell 1.6%. Kachemak City's population decreased by 3.0%, Seldovia City saw a 3.1% increase, and Soldotna's population gained 2.0%.

Executive Summary

SALES

The long-time reader of the KPB economic reports will note major changes in reporting of Borough sales. The long-awaited North America Industry Classification System (NAICS) has been implemented in the KPB sales database. This change was initiated due to signing of North American Free Trade Agreement (NAFTA), with implementation beginning on the federal level on January 1, 1994. As implementation was completed at the national level, Alaska began implementation, with the KPB following with an effective date of July 1, 2006.

The NAICS industry codes are substantially different from those of the out-dated Standard Industrial Classification (SIC) codes, with the number of major industry sectors increasing from nine to twenty. Clearly, all historical trends have become obsolete. This publication provides sales data by Line of Business (LOB) from 2000 to the present. Additional history will be presented as it becomes available.

Initial second quarter 2009 gross sales data indicate a 17.6% sales decrease from \$734,762,088 during second quarter 2008 to \$605,387,977. Of the 12 LOB categories reported, nine of them experienced decreasing sales and the remaining three reported gross sales increases. Taxable sales fell 14.4% or \$39,021,718 from \$271,135,550 during second quarter 2008 to \$232,113,832 for the same period in 2009. Eight LOBs reporting decreased sales with the remaining four reporting taxable sales increases. Of interest is the LOB for production which experienced a second quarter gross sales decrease of 16.3% yet a 16.2% increase in taxable sales.

Businesses that have less than \$6,000 in taxable sales annually, and meeting other reporting requirements, may opt to report yearly sales on an annual basis during fourth quarter rather than on a quarterly basis. This skews quarterly sales data, with fewer sales reported during first, second and third quarter, but increased sales reported during fourth quarter when annual sales reports are due. In addition to new software, additional reporting requirements have been implemented so some nontaxable sales not formerly required to be reported now are required reporting.

Quarterly Sales

Gross by Line of Business: Only three of the 12 LOBs enjoyed a second quarter 2009 increase from the same period in 2008. Utilities increased \$8,217,687 to \$37,992,431, or 27.6% over the second quarter 2008 total of \$29,774,744. Although construction permit values are down substantially for the second quarter 2009 compared to the second quarter of 2008, construction related sales are up. Construction related sales and services increased 13.6% or \$9,076,676 from \$66,812,991 for quarter two, 2008 to \$75,889,667 for quarter two, 2009. Rounding out the LOBs with gross sales increases is government related sales which include native corporations; and although modest, the second quarter 2009 increase of \$274,065 to \$4,217,393 is 7.0% greater than the second quarter 2008 total of \$3,943,328.

Executive Summary

LOBs with single digit decreases from the second quarter 2008 to the second quarter 2009 include general sales, professional services, general services, and property management. General sales slipped from \$209,904,567 to \$207,254,587, a decrease of \$2,649,980 or 1.3%. Professional services decreased 2.9% or \$537,053 from \$18,233,426 to \$17,696,373 for second quarter reporting periods. With gross sales of \$58,784,489 for the second quarter 2009, general services gross sales were \$3,368,730 less than the second quarter 2008 total of \$62,153,219, a decline of 5.4%. Closing out the LOBs with single digit losses is property management services. Decreasing 7.8%, property management services fell \$1,979,714 from \$25,231,660 for the second quarter, 2008 to \$23,251,946 for the same period in 2008.

LOBs suffering double digit decreases less than 50% compared to the previous year gross sales include wholesale, tourism, and production. Wholesale totals for the second quarter 2008 were \$91,634,047 and were \$64,608,591 for the second quarter 2009, a decrease of \$27,025,456 or 29.5%. As anticipated, tourism also suffered a decrease in both gross and taxable sales. Second quarter 2009 tourism gross sales of \$33,733,719 were \$13,442,235 less than the second quarter 2008 total of \$47,175,954, a 28.5% decline. The last LOB with a double digit decline of less than 50% was production. Production gross sales for the second quarter 2008 were \$41,226,009 falling \$6,726,825 to \$34,499,184, a decline of 16.3%.

The greatest decrease in gross sales for the second quarter of 2009 occurred in transportation and manufacturing, each falling 69.9% and 62.8% respectively. Transportation had second quarter 2008 total gross sales of \$57,776,253 and a second quarter 2009 total of \$17,363,902 for a decrease of \$40,412,351, or the 69.9% mentioned earlier. Manufacturing also sustained a significant decrease of \$50,800,250 from a second quarter 2008 total of \$80,895,890 to a second quarter 2009 total of \$30,095,640, or 62.8%. (See page 19 for detail)

Taxable by Line of Business: Faring a little better than gross sales, taxable sales decreased 14.4% from the second quarter 2008 total of \$271,135,550 to a second quarter 2009 total of \$232,113,832, a difference of \$39,021,718. Likewise, where there were only three LOBs with increases in gross sales, there were four with increases in taxable sales.

At 17.1%, utilities was the LOB with the greatest increase going from a second quarter record in 2008 of \$12,793,542 to a new second quarter record of \$14,975,178 in 2009, an increase of \$2,181,636. Although falling 16.3% in gross sales, production taxable sales increased 16.2% from what was also a second quarter record high in 2008 of \$2,216,863 to a new record in 2009 of \$2,575,450, an increase of \$358,587. Transportation also rallied with an increase of 11.2% or \$112,680 between the second quarter 2008 total of \$1,008,526 and the same period in 2009. Government taxable sales closed out the LOBs with an increase for the second quarter 2008 by climbing 5.9% from \$3,458,001 in 2008 to \$3,663,141, an increase of \$205,140.

Five LOBs experienced single digit declines in taxable sales with general services having the least with a negligible decrease of 0.1%. General services fell from a second quarter record of \$27,505,793 in 2008 by \$30,991 to \$27,474,802 in 2009. Property management declined

Executive Summary

6.7% from a second quarter record in 2008 of \$10,883,931 by \$725,950 to \$10,157,981 for the second quarter in 2009. Manufacturing saw a decrease from \$2,352,036 for the second quarter in 2008 to a second quarter 2009 total of \$2,181,243, a decline of \$170,793, or 7.3%. Construction taxable sales slipped 9.8% from a record second quarter total in 2008 of \$3,082,212 by \$301,180 to a 2009 second quarter total of \$2,781,032. Just barely under a double digit decline in taxable sales was professional services. With record second quarter taxable sales in 2008 of \$4,744,076, the second quarter 2009 total of \$4,276,311 reflects a decrease of \$467,765, or 9.9%.

Three LOBs suffered double digit decreases in sales which include general sales, wholesale, and tourism. General sales decreased \$23,969,671 or 17.3% from the second quarter 2008 total of \$138,921,134 to a second quarter total of \$114,951,463 in 2009. Wholesale taxable sales decreased by \$4,268,492 from a second quarter record of \$23,271,188 to \$19,002,696, a decline of 18.3%. Hardest hit in second quarter taxable sales was tourism which decreased 29.2% from a 2008 second quarter total of \$40,898,248 to \$28,953,329 for the same period in 2009, a decline of \$11,944,919. (See detail on page 20)

Gross by Area: All six areas of the borough experienced declines in gross sales for a borough wide decrease of 17.6%. Seldovia suffered the greatest percentage decline of 40.7% falling from \$2,591,665 during the second quarter in 2008 to \$1,537,661 for the same period in 2009. Soldotna incurred the least percentage decline at 5.1% with gross sales for the second quarter of 2008 of \$112,456,040 slipping by \$5,685,717 to \$106,770,323 in the second quarter of 2009. Homer gross sales for the second quarter fell 6.9% or \$7,157,601 from \$103,215,060 in 2008 to \$96,057,459 in 2009. Kenai experienced a significant decrease in gross sales of 28.3% resulting in a second quarter 2009 total of \$105,025,172 which was \$41,555,291 below the 2008 second quarter total of \$146,580,463. Compared to Kenai, Seldovia, and the rest of the borough, Seward fared a little better with second quarter 2009 sales of \$53,396,019 down \$6,418,377 or 10.7%, from the \$59,814,396 total for the same period in 2008. Sales outside the incorporated cities decreased 21.8% to \$242,601,288, down \$67,503,177 from the second quarter in 2008 total of \$310,104,465. (See detail on page 21)

Taxable by Area: Of the six KPB regions, five experienced a decrease in taxable sales with only Kenai showing an increase. Kenai suffered a significant decline in gross sales, but enjoyed a \$1,644,174, or 3.7% second quarter 2009 taxable sales increase to \$46,504,382. Soldotna experienced the least percentage decrease with a decline of \$2,662,459, or 4.2% from a record \$63,179,312 for the second quarter 2008 to \$60,516,853 for 2009. Seward taxable sales decreased 12.4% from \$30,194,399 in the second quarter of 2008 to \$26,440,658, a decline of \$3,753,741. Homer also experienced a noticeable decline in second quarter taxable sales from \$48,871,596 in 2008 to \$40,262,341 for the same period in 2009, a decrease of \$8,609,255 or 17.6%. The KPB area excluding the cities also experienced a decrease in taxable sales by falling 30.3% from \$271,135,551 in 2008 during the second quarter to \$232,113,382 in 2009, a decrease of \$39,021,719. Hardest hit with a decrease in taxable sales was Seldovia, falling 42.4% from a second quarter record high of \$1,663,391 in 2008 to \$958,005 in quarter two of 2009, a decrease of \$705,386. (See detail on page 22)

Executive Summary

Year to Date Sales

Year-to-date sales indicate a mix, with five LOBs enjoying increases and seven suffering decreases with a borough wide decline in gross sales of 5.6% and taxable sales decrease of 15.0%.

Gross by Line of Business: Of the five LOBs with gross sales increases, utilities had the highest percentage increase of 37.1% which is a \$24,269,203 increase from \$65,471,552 in 2008. Wholesale activities also enjoyed a significant increase of \$47,519,020, or 30.5% over the year to date 2008 total to set a new record of \$203,365,378. Year to date construction sales enjoyed a modest increase of 6.4% by generating a 2009 year to date activity of \$120,540,064 which is a \$7,275,195 increase over 2008 and a new second quarter year to date record. Government gross sales increased in 2009 over 2008 with a year to date total of \$7,795,814 which reflects an increase of \$430,771 or 5.8%. Production was the last of the LOBs to experience a second quarter year to date increase for 2009 by experiencing a 4.3% increase of \$3,003,715 for a total of \$72,629,507.

Of the seven LOBs suffering gross sales decreases, general services experienced the least at 2.0%, a decrease of \$2,147,009 to \$103,524,454. General sales experienced a minor decrease of \$9,209,267, or 2.6% from the 2008 second quarter year to date total of \$357,134,618 to \$347,925,351 in 2009. Professional services also saw a decline in gross sales by falling \$1,705,884 to \$31,564,021, a 2008 second quarter year to date loss of 5.1%. Completing the list of those LOBs with a single digit year to date decrease is property management services which fell 3.6% to \$42,628,371, a decrease of \$1,608,834 from 2008 to 2009.

Suffering double digit losses were tourism, manufacturing, and transportation. The 2009 second quarter year to date total for tourism of \$40,386,635 was 27.0% below that of 2008, a decrease of \$14,939,059. Manufacturing experienced a significant decline of 47.3% for a 2009 second quarter year to date total of \$62,896,089, which is \$56,544,774 below the 2008 second quarter year to date record of \$119,440,863. Transportation suffered the greatest decrease in gross sales at 66.8% which is a \$65,336,498 decrease from the 2008 second quarter year to date record of \$97,792,222. (See detail on page 23)

Taxable by Line of Business: Leading the LOBs in taxable sales increase is utilities with a 2009 year to date new record 30.9% increase of \$9,095,524 to \$38,523,864. Although suffering a staggering decrease in gross sales, transportation enjoyed an increase of \$284,691, or 18.1% in taxable sales to a 2009 second quarter year to date total of \$1,855,948. Production activities also enjoyed a double digit taxable sales increase of 14.8% to \$3,704,427, adding \$478,811 to the 2008 same period total. Government taxable sales increased \$274,225, or 4.4% to \$6,464,437, and general services closed out the LOB's with sales tax increases at 1.8% or \$921,583 to a 2009 second quarter year to date total of \$50,771,314.

Executive Summary

Of the seven LOBs experiencing declines in taxable sales, property management experienced the least at 4.3%, falling \$806,625 to a 2009 second quarter year to date total of \$17,995,714. Manufacturing taxable sales slipped \$255,911 or 7.7% to 3,057,183 in 2009 from the 2008 second quarter year to date total of \$3,313,094. Professional services was the last LOB for this period to experience only a single digit decline by slipping 8.4%, or \$754,102 from the 2008 year to date total of \$9,013,206 to \$8,259,104 for the same period in 2009. Construction experienced the smallest double digit decline at 11.2%, falling \$611,807 to \$4,845,058 from the 2008 second quarter year to date total of \$5,456,865. Wholesale taxable sales fell 16.7% from a 2008 second quarter year to date total of \$40,331,098 to \$33,593,471, a decline of \$6,737,627. General sales suffered significantly as well with a 23.8% decline of \$55,927,870 to 178,594,654 from a 2008 second quarter year to date record of \$234,522,524. Tourism suffered the largest taxable sales loss of 28.1% which decreased the 2008 second quarter year to date total of \$47,788,046 by \$13,418,373 to \$34,369,673 for the same period in 2009. (See detail on page 24)

Gross by Area: Each of the five reporting cities experienced declines in gross sales with only the remaining combined area of the borough enjoying an increase. Areas outside the incorporated cities experienced a gross sale increase of 5.9% or \$29,724,133 to a new second quarter year to date record of \$537,431,550. Homer fared better than the other cities with a decrease of 4.4% to \$161,569,253 which was \$7,353,925 less than the 2008 second quarter year to date record of \$168,923,178. Seward saw gross sales slip by 5.5% or \$4,716,122 from \$86,320,465 for the second quarter year to date in 2008 to \$81,604,343 in 2009. Soldotna second quarter 2009 year to date sales fell \$15,079,363 or 7.5% from a 2008 record of \$201,994,070 to \$186,914,707. Kenai suffered a significant gross sales decline of 27.6% losing \$70,373,845 from the 2008 record of \$255,392,538. Seldovia experienced the greatest percentage loss at 29.1% when the 2008 second quarter year to date total of \$4,107,916 slipped by \$1,194,299 to \$2,913,617 for the same period in 2009. (See detail on page 25)

Taxable by Area: Taxable sales reflected a shift more so than a trend as one of the five cities, Kenai experienced not only an increase in sales, but a new record while the remainder of the borough outside the cities experienced a decrease in taxable sales. Kenai taxable sales increased \$2,802,688, or 3.5% to \$83,862,290 which exceeds the previous record for the second quarter year to date total of \$81,059,602 that was set in 2008. Slipping only slightly, Soldotna taxable sales decreased 3.0% to \$107,476,705 a decline of \$3,363,158 from 2008. Seward sales decreased from \$41,534,052 for the second quarter year to date in 2008 to \$36,776,773 for the same period in 2009, a decline of \$4,757,279 or 11.5%. Homer taxable sales decreased 19.3% from \$77,894,513 in 2008 to \$62,851,835, a difference of \$15,042,678. Seldovia again suffered the greatest percentage loss of 31.0% or a decline of \$778,926 from the 2008 total of \$2,513,623. The remaining areas outside the incorporated cities experienced a 26.1% decrease in sales dropping \$35,406,682 to \$100,243,993 from \$135,650,675 for the second quarter year to date total in 2008. (See detail on page 26)

Executive Summary

Annual Sales

KPB 2008 gross sales increased 12.6% to \$3,159,657,109 from the 2007 total of \$2,805,925,989, gaining \$353,731,120. This follows 3.9% growth during 2007 and 5.0% during 2006.

Taxable sales increased 6.2% from 2007 to 2008 with sales reaching \$1,026,854,330, following an 8.9% increase from 2006 to the 2007 level of \$967,190,987, and a 7.6% gain from 2005 to 2006.

Gross by Line of Business: Ten of twelve LOBs experienced increased sales when comparing 2008 to 2007 with one LOB having gains greater than \$100 million, and three with gains greater than \$50 million. Manufacturing sales had the highest percentage increase at 33.6% for a difference of \$66,065,508 between the 2008 yearly total of \$262,581,508 and the 2007 total of \$196,516,138 for the same period. Transportation & warehousing sales increased 32.8% to reach \$219,186,646 increasing \$54,116,143 over the \$165,070,503 in sales a year ago. Sale of wholesale goods gained \$95,519,385 to reach \$629,233,693, a 17.9% increase. The largest dollar gain was in general sales with an increase of \$115,635,158 from the annual 2007 total of \$693,839,923 to \$809,475,081, or 16.7% for the 2008 annual total.

Services sales produced a 13.0% annual increase in 2008 with total sales of \$223,400,639 which was \$25,614,900 more than the annual 2008 total of \$197,785,739. Utility sales were up 12.7% as they reached \$136,700,502, a \$15,380,652 increase over the 2008 total of \$121,319,850. Rounding out the double digit increases was production sales with a 10.9% increase for the 2008 yearly total with sales of \$220,624,624 which was \$21,771,667 over the previous year's total sales of \$198,852,957.

With lesser numerical gains, professional sales increased \$6,695,787, a 9.7% gain, to total \$75,773,077. Government sales increased 5.8% or \$948,095 to \$17,314,932 and lastly with increases were property related sales with an increase 5.0%, or \$4,751,832 to reach \$99,601,202.

Tourism suffered the greatest decline at 25.0% with sales only reaching \$155,553,194 or \$51,902,757 below the annual 2008 total of \$207,455,951. Construction sales for 2008 experienced a minimal decline of 0.3% to \$310,212,011, just \$865,112 below the previous year total of \$311,077,123. (See detail on page 27)

Taxable by Line of Business: Taxable sales during 2008 were 6.2% greater than those of 2007 as 10 of 12 LOBs experienced increasing sales. Total taxable sales of \$1,026,854,330 were \$59,663,343 more than during 2007 when total KPB sales were \$967,190,987.

Transportation & warehousing sales rose for the fourth consecutive year at 25.5% or \$739,892 to \$3,644,236, the largest percentage increase. General sales rose by 19.0% in 2008 to \$538,927,936. Resource production sales of \$6,694,810 were 12.7% greater than

Executive Summary

during 2007 when sales totaled \$5,940,404. Service sales of \$106,613,261 were 10.8% above that one year earlier when sales totaled \$96,224,461.

With single-digit percent gains, utility sales each rose 6.6% to reach \$56,985,954 and property related sales rose 6.3% to \$41,708,890. Taxable wholesale sales grew by 5.0%, with \$86,329,055. Professional and construction sales each grew by 3.2% with 2008 totals of \$17,965,101 and \$12,610,340 respectively. Government sales completed the LOBs with increases with \$14,631,227 or 3.1% over the 2007 annual total of \$14,194,814.

As with gross sales, tourism experienced the greatest decline in taxable sales slipping 26.8% to a 2008 total of \$132,133,153 which is \$48,378,954 below the 2007 total of \$180,512,107. Manufacturing also suffered a 15.3% decrease in sales with a total of \$8,880,367 or \$1,606,297 below the 2007 total of \$10,486,664. (Detail on page 28)

Gross by Area: KPB gross sales increased in five of the six areas as annual gross sales gained 12.6% from the 2007 to the 2008 total. The 2008 total in gross sales was \$3,159,657,109. Kenai 2008 sales, \$607,676,556, were 16.7% greater as construction sales gained over \$55 million. Sales outside the cities increased by \$182,677,501 to \$1,480,554,810, a 14.1% gain as government sales doubled to over \$53,750 and services sales grew over \$8 million. Soldotna sales reached \$465,405,888, a modest gain of 8.4% as retail sales grew by \$58 million and transportation sales increased by 88.7%, a \$5 million over 2007. Seward gross sales increased by 9.9% to \$214,574,775 as construction and professional sales both grew by nearly 50% with annual totals of \$30,696,120 and \$6,058,799 respectively. Homer completes the list of areas with positive gains with an 8.3% increase in gross sales of \$29,462,149 to a 2008 total of \$382,914,299.

Only Seldovia experienced declining sales with a 2008 total of \$8,530,781 which is 8.3% less than the 2007 total of \$9,495,815. The decline is attributed to the decrease in sales in six of the twelve LOBs. (See detail on page 29)

Taxable by Area: Taxable sales increased in each reporting area when comparing 2008 sales with those of 2007 as annual sales increased 6.2% to \$1,026,854,330. The greatest percentage growth came again in Seldovia, 15.9%, where sales reached \$5,004,876, gaining \$687,148 over the 2007 total, \$4,317,728. With sales increasing 8.2%, the Other KPB region sales reached \$306,848,624. This is \$23,304,639 greater than 2007 sales of \$283,543,985. Soldotna saw a sales increase of 7.2%, or \$17,599,562, to \$261,094,783, up from the 2007 total, \$243,495,221. Kenai sales of \$175,891,484 were 5.3% above 2007 and \$8,814,106 greater than the previous total, \$167,077,378. With 3.9% growth, Homer sales reached \$173,010,794, gaining \$6,509,845 over 2007 sales of \$166,500,949. Lastly, Seward's annual sales were 2.7% above those of 2007. The 2008 total reached \$105,003,769, up \$2,748,043 over the 2007 total, \$102,255,726. (See detail on page 30)

Executive Summary

CONSTRUCTION PERMITTING

Quarterly Permitting

With permit values totaling \$22,164,945 and 118 permits issued, construction activity values for the quarter were well below the 2008 record year totals of \$42,695,985 and 127 permits, respectively for a 48.1% decrease in quarterly construction activity. As 2008 was unusually high, the average activity for the years 2003 through 2007 is included as well. The average for those years is \$21,142,687, and 129 permits. Compared to the average, the second quarter 2009 is 4.8% higher

By Area, Value: Seward set a new record with construction permits totaling \$10,958,799 which is more than 490% over the second quarter, 2008 total of \$1,844,464 and breaks the previous second quarter record of \$7,433,900 set in 2004. Seldovia also enjoyed a substantial increase from \$7,500 for the second quarter to \$307,500 for the second quarter 2009, although still below the 2004 record of \$466,000.

Soldotna experienced a modest increase of 1.1% from \$5,212,121 for the second quarter of 2008 to \$5,294,876 while Homer and Kenai each suffered significant decreases in excess of 80% for construction activity. Kenai decreased from a 2008 second quarter record of \$18,890,900 to a 2009 second quarter total of \$3,213,270, a decline of 83.1%. Homer also declined from a 2008 second quarter record of \$16,651,000 to \$2,390,500 for the second quarter 2009, a decrease of 85.6%. Total permitting value for the borough for the second quarter of 2009 was \$22,164,945, a 48.1% decrease from the 2008 second quarter total of \$42,695,985. (See detail on page 36)

By Area, Volume: Soldotna issued the most permits for the second quarter of 2009 at 42, an increase of five over the second quarter of 2008. Kenai issued 31 permits during the second quarter of 2008, well below the 2008 second quarter record of 45. Seward issued 22 permits, nearly double the 2008 second quarter total of 12. There were 19 permits issued in Homer for the second quarter 2009 reporting period, noticeably less than the same period in 2008. Seldovia doubled its second quarter permits from two in 2008 to four in 2009. (See detail on page 36)

By Type, Value: With a KPB total permit value of \$22,164,945, the majority of value was for new commercial construction, \$11,010,639. New residential projects added \$7,997,945. Commercial alteration/addition permitting provided \$2,550,826 in assessed value while residential alteration/addition permitting added another \$605,535. Total values were substantially lower than second quarter 2008 in all categories except for commercial alteration/addition. (See detail on page 37)

By Type, Volume: 42 permits were issued for new residential homes during the second quarter of 2009, down from 56 during the same quarter one year ago. 40 permits were issued for residential alterations or additions, up from 37 during the 2008 second quarter.

Executive Summary

Commercial alteration projects increased from 26 to 28 permits. Lastly, eight new commercial projects were permitted, the same number issued during second quarter 2008. (See detail on page 37)

Year to Date Permitting

By Area, Value: After a slow first quarter, permitting made only modest gains during second quarter 2009 well below the record levels set the year before. Total year-to-date permit assessed values stand at \$30,849,065, down 35.3% from \$47,709,953 one year ago. Seward and Seldovia have increased values over one year ago, Seward at a record \$17,585,919 and Seldovia with \$307,500. Each of the other areas have decreased values. Soldotna permits had a total assessed value of \$5,747,876, Homer's total stands at \$3,501,500 and Kenai issued permits totaling \$3,706,270. (See detail on page 38)

By Area, Volume: Soldotna issued 53 permits, five less than a year ago, while Kenai issued 38 permits, 19 less than year-to-date 2008. With 29 permits, Seward activity was up 12 permits issued over year-to-date 2008. Homer dropped from 38 permits to 23 while Seldovia increased from three to four permits. (See detail on page 38)

By Type, Value: Of the \$30,848,065 total assessed value of permits issued, \$8,627,945 was for new residential projects. New commercial permitting added another \$12,038,639 and commercial alteration/ addition projects added another \$9,313,946. Residential alteration/addition projects completed the picture with \$867,535 in value. (See page 39 for detail.)

By Type, Volume: Permits were issued for 45 new homes, down from 64 a year ago while new commercial permitting dropped from 13 to 12 permits. Residential alteration/addition projects added another 51 permits, up from the 47 of the 2008 year-to-date. Commercial alteration/addition permits decreased from 49 to 39. (See page 39 for detail.)

Annual Permitting

2008 construction permit total value of \$92,344,635 has exceeded all previous records. Construction permit values during 2004 totaled \$84,041,457, exceeding the previous high of 1995 when total value reached \$61,670,382. Activity during 2005 dropped to \$44,733,803, but 2006 nearly reached the 2004 level as \$80,230,660 in permit value was issued. The 2007 total, \$71,656,850, was less than the 2006 total but showed strength as it ranked fourth highest on record. Permits are required for projects within KPB cities but the KPB itself does not require building permits.

The 304 construction permits issued marked the lowest total behind 351 issued during 2002. The 2005 total volume was 338 permits, down from 2003 with 336 permits, second and third highest on record. There were 323 permits issued during 2006, eleven less than during 2007.

Executive Summary

By Area, Value: KPB's 2008 total permitted value reached \$92,362,635, a 28.9% increase over the 2007 total of \$71,656,850. Kenai, with a 2008 total permit value of \$46,486,375, accounted for 50.3% of the KPB annual total, and gained 107.5% over the city's 2007 total of \$22,398,000. Both new commercial permitting and commercial alteration/additions in Kenai passed the \$15 million mark while housing values totaled \$5.8 million. Homer saw a 64.8% gain to \$23,168,200 from \$14,056,202 during 2007 with strength closely matched in both the residential and commercial markets.

Soldotna's total, \$19,493,181 while only 21.1% of the KPB total, was up 41.6% from the 2007 total of \$13,762,923. Soldotna new commercial construction value of \$13,119,066 reflects 67.3% of total permitted value. Seward added \$2,832,379 to the KPB total but dropping 86.6% from the 2007 total, \$25,537,249. Seward's permit activity plummeted in all areas except commercial alteration or addition which grew from \$21,500 in 2007 to \$192,000 for 2008. (See detail on page 40)

By Area, Volume: With 304 building permits issued for the year, 114 were issued in Kenai, 37.5% of the KPB total, two more permits than during 2007. Soldotna issued 91 permits, 11 more than a year ago, providing 29.9% of the KPB total. Homer added 62 permits for 20.4%, down from 87 permits issued during 2007. Seward's 30 permits were seven fewer than the 37 permits issued last year, and 9.9% of the KPB total. Lastly, Seldovia issued seven permits, down from 18 issued during 2007, 2.3% of the KPB total. (See detail on page 40)

By Type, Value: New commercial permitting provided 66.1% of 2008 annual permit value with \$61,078,166 of the \$92,362,635 KPB total. New commercial permitting was 79.7% more than 2007. New residential projects added \$21,563,338, down 4.6% from \$22,162,367 issued a year earlier. Commercial alteration/addition permitting added \$6,992,543, down 36.4% from 2007, while residential alteration/addition activity added \$2,728,588, down 33.6% from a year earlier. (See detail on page 41)

By Type, Volume: Construction permit volume declined 9.0% during 2008, with decreased activity in all areas except commercial alteration/addition which increased 16.2% from 68 permits in 2007 to 79 permits in 2008. New commercial permit volume fell to 105 from 119 reflecting a 27.0% loss. New residential permits issued fell 15.5% to 93 in 2008 from 110 a year earlier. Residential alteration/addition permits also declined to 105 falling 11.8% below the 2007 total of 119. (See detail on page 41)

UNEMPLOYMENT

Unemployment statistics are received from the Alaska Department of Labor on a monthly basis. The data are developed from a survey of residents across the state with survey results input into a nationwide model. The detail is not an actual count, but rather an estimate based upon survey response calculations using a standardized model that is used across the USA.

Executive Summary

The April 2009 estimate of the KPB labor force was 25,594 persons, up from 25,374 during April 2008. The May total of 27,305 was up from 26,786 a year ago. The June total, 28,515, was greater than the 28,189 of June 2008. The year-to-date average monthly labor force was 398 persons greater than the 2008 average for the first six months, 26,270 individuals.

There were 2,852 unemployed persons in the KPB during April 2009, up from 2,333 one year ago. During May unemployment rose to 2,664, up from 2,038 one year earlier. The June 2009 count increased to 2,742, more than the estimated 2,063 unemployed total during June 2008. The unemployment average of 2,961 during the first half of 2009 was 624 persons more than the 2008 first half of 2,337 individuals.

KPB's April 2009 unemployment rate of 11.1% was up from 9.2% during April 2008. The rate took a downturn to 9.8% during May and declined further to 9.6% in June. The May 2008 rate was 7.6% while the June rate was 7.3% last year. The 2009 average first half unemployment rate was 11.3%, compared to the 2008 for first half average rate of 9.2%.

April 2009 employment decreased to 22,742 from the 23,041 estimated a year earlier. May saw a similar decrease as employment moved down from 24,748 to 24,641. June followed suit as employment slipped to 25,776 from 26,126. The year-to-date average employment decreased by 210 jobs from 23,519 during first half 2008 to 23,309 during the first half of 2009. (See detail on pages 46 and 47)

POPULATION

Population estimates for 2008 show the Kenai Peninsula population at 52,990 persons, a 1.1% increase for the year. Since Census 2000, the KPB natural increase (births minus deaths) has been a gain of 3,299 persons, and in the past year, 583 persons. Other changes are due to in or out migration.

CDP's and cities with the greatest estimated change from 2007 to 2008 include Soldotna, with a gain of 79 persons while Diamond Ridge and Nikiski each gaining 61, and Fritz Creek gaining 52. The most noticeable losses were Homer with a decline of 112 residents and Tyonek losing 27. The remaining population was relatively unchanged. (See page 49 for detail.)

The 2008 median age is estimated at 33.5 years for Alaska and 39.2 years for the KPB. Comparing the KPB with Alaska's largest boroughs, the KPB has the oldest population. Juneau follows with a median age of 38.1 years. The Matanuska-Susitna Borough follows with an average age of 34.2 years while the Municipality of Anchorage stands at 33.2 years. Of the large boroughs, Fairbanks has the youngest median age of 31.4 years.

THIS PAGE INTENTIONALLY LEFT BLANK

**KENAI
PENINSULA
BOROUGH**

KPB Sales

KPB sales data includes detail from Homer, Kenai, Seldovia, Seward, Soldotna and "Other" - which indicates KPB regions outside boundaries of the five incorporated cities and Kachemak City, which does not impose a sales tax. The 3% KPB sales tax is included in city rates listed below. The balance is imposed by each city. KPB sales tax assessments increased from 2% to 3%, effective January 1, 2008. Proceeds will continue to be dedicated to the KPB school district.

Sales are reported by the Line of Business (LOB) listed on each establishment's business license application.

Sales data presented is accurate as of February 11, 2008

7.5%	7.0%	6.0%	5.0%	3.0%
Homer	Seward	Kenai	Seldovia	Other
Seldovia (April - September)		Soldotna	(October - March)	

Table 1.1

Gross and taxable sales data are received quarterly through Sales Tax Returns from KPB businesses. Exempt sales include:

- | | |
|-------------------------------|--|
| Sales outside the borough; | Sales to tax exempt organizations; and |
| Sales for resale; | Sales in excess of \$500. |
| Sales to government agencies; | |

Due to concerns of releasing proprietary information, similar LOB's have been grouped into categories.

LOB abbreviations and LOB's included in each category are listed below.

PROD	Resource Production	Agriculture, Forestry, Mining - (Includes oil and gas exploration, gravel) Timbering
MFG	Manufacturing	Manufacturing - (Includes oil and gas manufacturing, fish processing)
CONST	Construction	Construction
SALES	Sales	Restaurant, Bar Retail
PROP	Rentals	Rental Commercial Property Rental Residential Property Rental Personal Property Rental Non-residential Properties Trailer Court
TOUR	Tourism	Arts, Entertainment, Recreation Guiding Land* Guiding Water* Accommodation
SERV	Services	Administration, Support, Waste Management, Remediation Educational Services Finance and Insurance Information Other Services Remediation Services Cable Telecommunications
PROF	Professional	Health and Social Services Management of Companies, Enterprises Professional, Scientific, Technical
UTIL	Utilities	Utilities
TRAN	Transport/ Warehouse	Transportation and Warehousing*
WHSL	Wholesale	Wholesale
GOV	Public Administration	Public Administration - (Includes Native Organizations)

Table 1.2

* - LOB totals are unstable until our software conversion is complete. This quarter, sales in transportation, guiding by land and guiding by water show marked differences as 2006 and 2007 sales have been updated, but not 2005 and prior.

KPB Sales

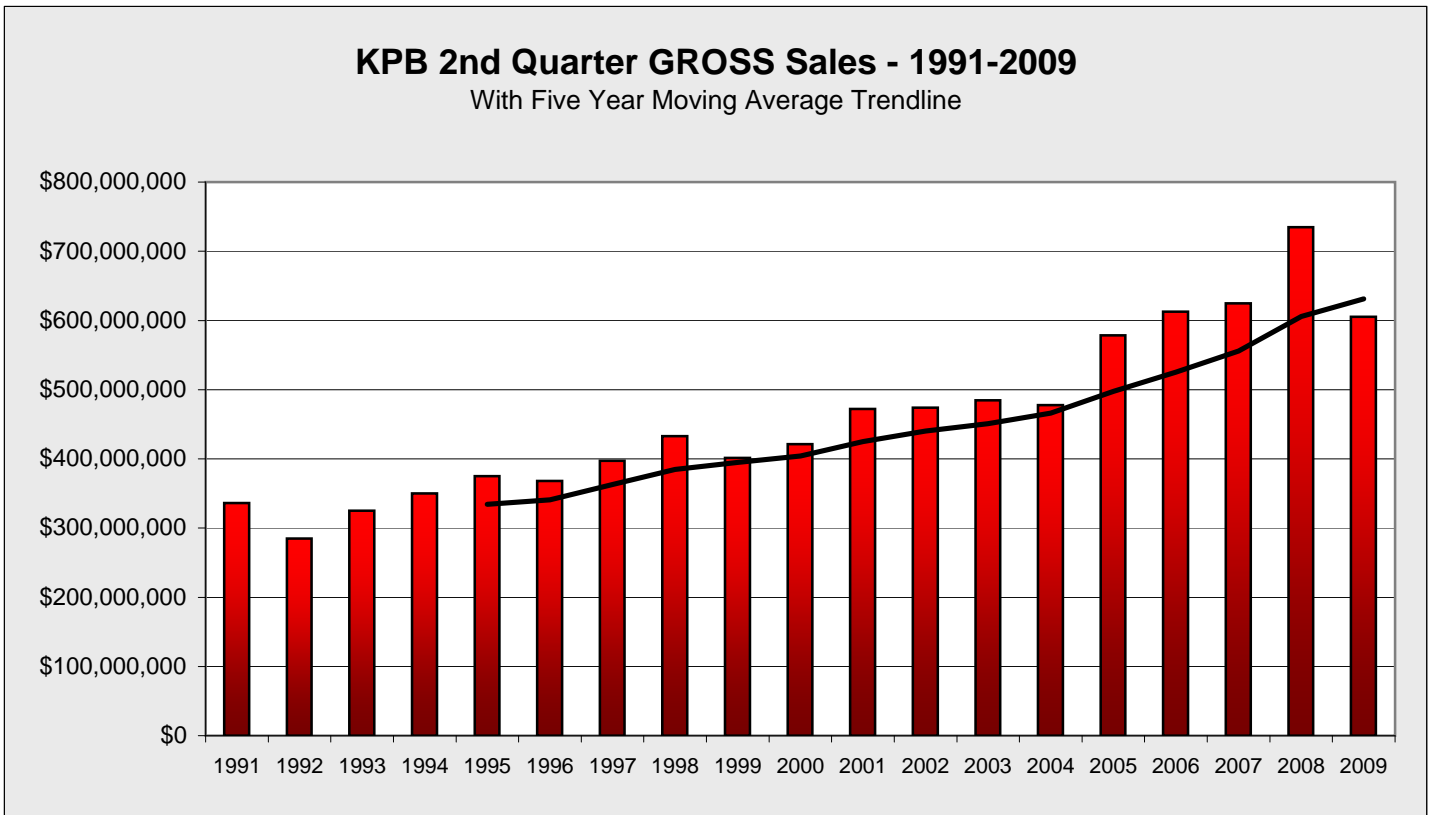

Chart 1.1

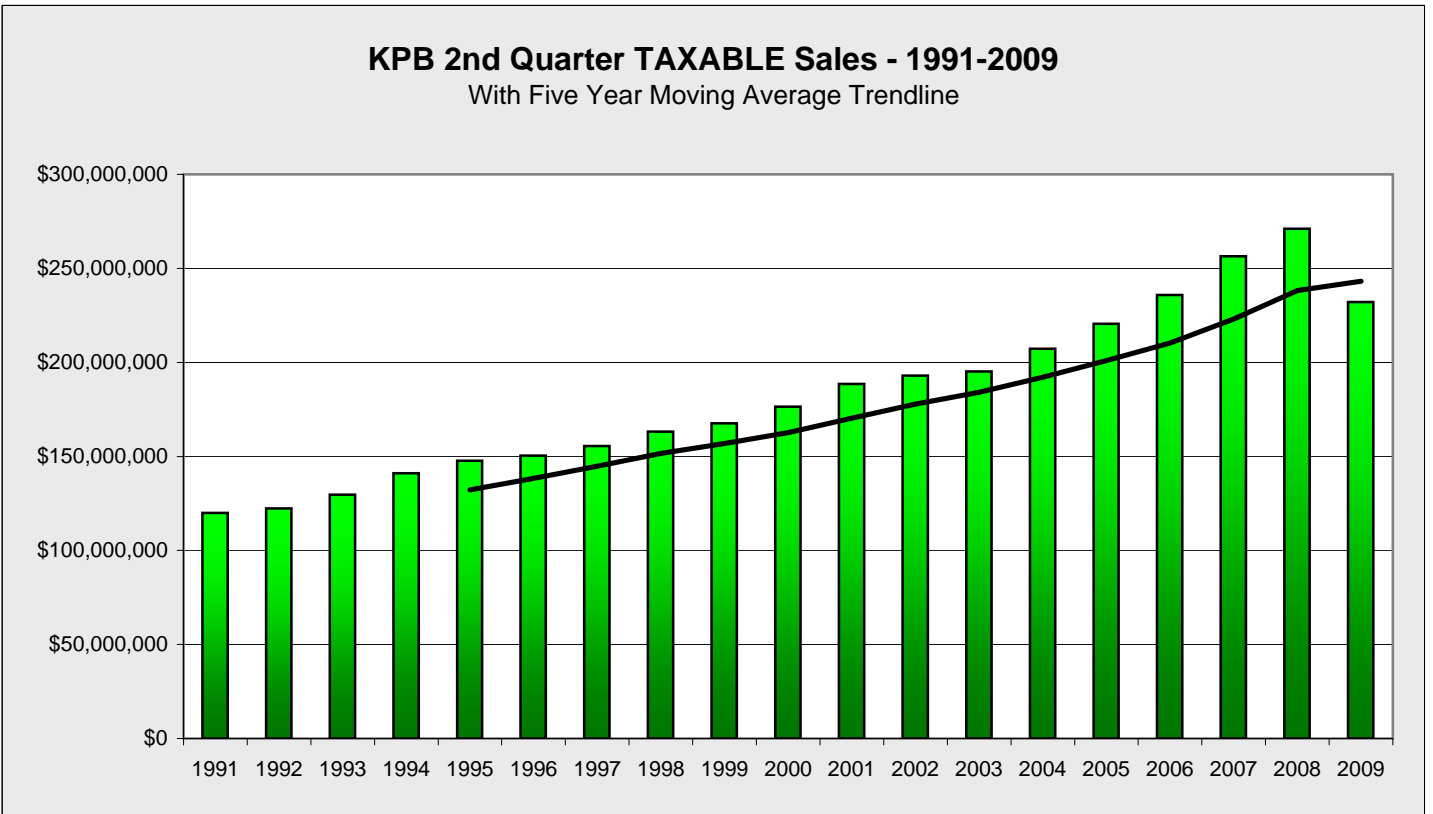

Chart 1.2

KPB Sales

KPB 2nd Quarter GROSS Sales by Line of Business - 2004-2009- in \$*								
LOB	2004	2005	2006	2007	2008	2009	Annual Amount Change	Annual Percentage Change
PROD	36,931,888	33,642,771	43,839,219	37,089,155	41,226,009	34,499,184	-6,726,825	-16.3%
SALES	107,357,845	168,091,583	178,965,036	181,702,272	209,904,567	207,254,587	-2,649,980	-1.3%
CONST	25,675,314	66,443,812	59,781,577	71,115,474	66,812,991	75,889,667	9,076,676	13.6%
PROP	16,557,624	20,731,568	22,740,383	23,009,451	25,231,660	23,251,946	-1,979,714	-7.8%
TOUR	16,011,089	54,963,368	58,865,867	59,439,612	47,175,954	33,733,719	-13,442,235	-28.5%
SERV	25,765,288	37,026,822	42,838,322	53,832,707	62,153,219	58,784,489	-3,368,730	-5.4%
PROF	11,505,526	11,903,224	14,165,049	15,388,743	18,233,426	17,696,373	-537,053	-2.9%
UTIL	22,389,233	23,278,511	26,961,172	30,112,352	29,774,744	37,992,431	8,217,687	27.6%
MGF	24,108,267	58,551,604	55,022,566	46,774,719	80,895,890	30,095,640	-50,800,250	-62.8%
TRAN	12,385,881	36,061,931	37,237,524	34,761,160	57,776,253	17,363,902	-40,412,351	-69.9%
WHSL	59,563,838	65,621,437	68,421,938	67,298,261	91,634,047	64,608,591	-27,025,456	-29.5%
GOV	2,655,152	3,414,800	3,670,790	3,968,840	3,943,328	4,217,393	274,065	7.0%
TOTAL	360,906,945	579,731,431	612,509,443	624,492,746	734,762,088	605,387,922	-129,374,166	-17.6%
Annual Change		60.6%	5.7%	2.0%	17.7%	-17.6%		

Table 1.3 * - For complete Line of Business (LOB) listing, see page 17.

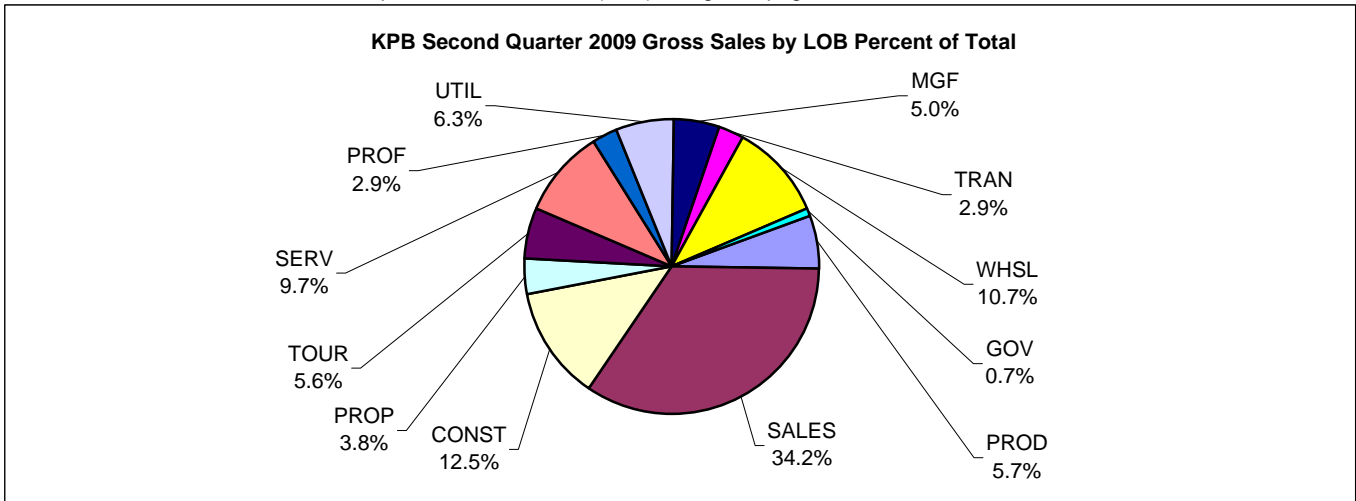

Chart 1.3

Second Quarter Gross Sales Five Year Change by LOB				
LOB	2004	2009	Value Change	Percent Change
PROD	36,931,888	34,499,184	-2,432,704	-6.6%
SALES	107,357,845	207,254,587	99,896,742	93.1%
CONST	25,675,314	75,889,667	50,214,353	195.6%
PROP	16,557,624	23,251,946	6,694,322	40.4%
TOUR	16,011,089	33,733,719	17,722,630	110.7%
SERV	25,765,288	58,784,489	33,019,201	128.2%
PROF	11,505,526	17,696,373	6,190,847	53.8%
UTIL	22,389,233	37,992,431	15,603,198	69.7%
MGF	24,108,267	30,095,640	5,987,373	24.8%
TRAN	12,385,881	17,363,902	4,978,021	40.2%
WHSL	59,563,838	64,608,591	5,044,753	8.5%
GOV	2,655,152	4,217,393	1,562,241	58.8%
TOTAL	360,906,945	605,387,922	244,480,977	67.7%

Table 1.4

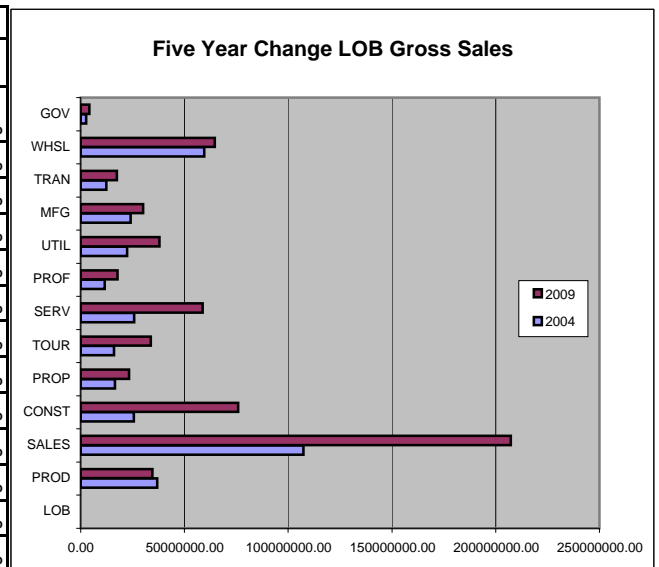

Chart 1.4

KPB Sales

KPB 2nd Quarter TAXABLE Sales by Line of Business - 2004-2009- in \$*								
LOB	2004	2005	2006	2007	2008	2009	Annual Amount Change	Annual Percentage Change
PROD	1,822,647	1,790,259	1,823,191	2,039,567	2,216,863	2,575,450	358,587	16.2%
SALES	96,283,124	103,212,569	109,433,886	117,658,028	138,921,134	114,951,463	-23,969,671	-17.3%
CONST	2,918,853	2,908,756	2,944,819	3,034,410	3,082,212	2,781,032	-301,180	-9.8%
PROP	7,927,956	8,187,746	8,531,207	9,952,399	10,883,931	10,157,981	-725,950	-6.7%
TOUR	33,690,401	45,271,944	48,415,782	53,007,670	40,898,248	28,953,329	-11,944,919	-29.2%
SERV	19,940,356	20,854,296	22,111,917	25,559,364	27,505,793	27,474,802	-30,991	-0.1%
PROF	3,761,871	3,953,049	4,536,924	4,611,238	4,744,076	4,276,311	-467,765	-9.9%
UTIL	7,946,772	9,357,261	10,663,883	11,944,498	12,793,542	14,975,178	2,181,636	17.1%
MGF	1,847,946	2,035,398	2,446,548	2,817,887	2,352,036	2,181,243	-170,793	-7.3%
TRAN	10,755,001	645,635	889,688	791,238	1,008,526	1,121,206	112,680	11.2%
WHSL	17,390,769	19,096,007	20,819,810	21,240,013	23,271,188	19,002,696	-4,268,492	-18.3%
GOV	2,997,995	3,081,459	3,244,865	3,446,756	3,458,001	3,663,141	205,140	5.9%
TOTAL	207,283,691	220,394,379	235,862,520	256,103,068	271,135,550	232,113,832	-39,021,718	-14.4%
Annual Change		6.3%	7.0%	8.6%	5.9%	-14.4%		

Table 1.5

* - For complete Line of Business (LOB) listing, see page 17.

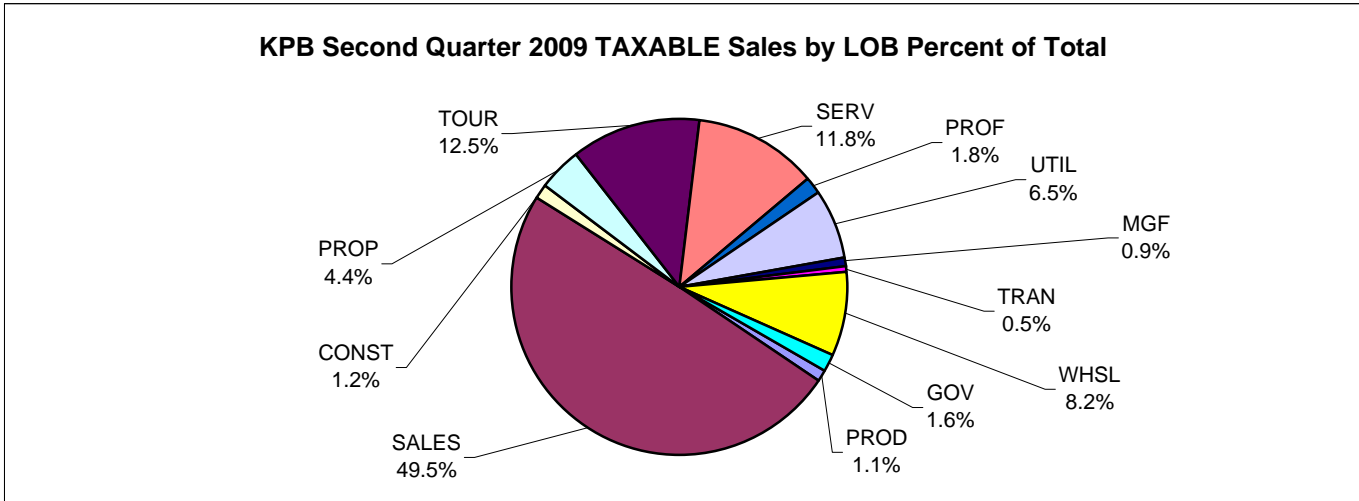

Chart 1.5

Second Quarter TAXABLE Sales Five Year Change by LOB				
	2004	2009	Value Change	Percent Change
PROD	1,822,647	2,575,450	752,803	41.3%
SALES	96,283,124	114,951,463	18,668,339	19.4%
CONST	2,918,853	2,781,032	-137,821	-4.7%
PROP	7,927,956	10,157,981	2,230,025	28.1%
TOUR	33,690,401	28,953,329	-4,737,072	-14.1%
SERV	19,940,356	27,474,802	7,534,446	37.8%
PROF	3,761,871	4,276,311	514,440	13.7%
UTIL	7,946,772	14,975,178	7,028,406	88.4%
MFG	1,847,946	2,181,243	333,297	18.0%
TRAN	10,755,001	1,121,206	-9,633,795	-89.6%
WHSL	17,390,769	19,002,696	1,611,927	9.3%
GOV	2,997,995	3,663,141	665,146	22.2%
TOTAL	207,283,691	232,113,832	24,830,141	12.0%

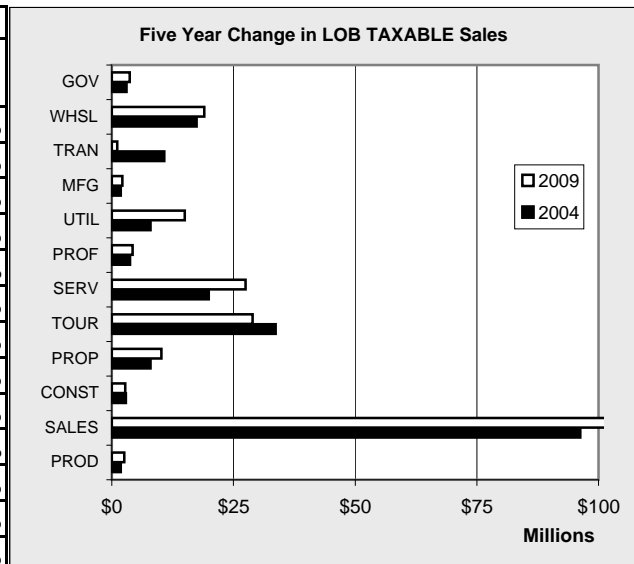

Chart 1.6

KPB Sales

KPB 2nd Quarter GROSS Sales by Area - 2004-2009 - in \$								
	2004	2005	2006	2007	2008	2009	Annual Amount Change	Annual Percent Change
Homer	75,752,214	85,895,824	89,314,280	97,290,718	103,215,060	96,057,459	-7,157,601	-6.9%
Kenai	80,388,089	102,543,222	109,278,718	111,960,372	146,580,463	105,025,172	-41,555,291	-28.3%
Seldovia	1,971,670	2,120,534	2,170,811	2,550,793	2,591,665	1,537,661	-1,054,004	-40.7%
Seward	42,749,272	58,409,308	51,092,715	56,608,855	59,814,396	53,396,019	-6,418,377	-10.7%
Soldotna	89,310,129	87,630,570	99,012,814	102,966,180	112,456,040	106,770,323	-5,685,717	-5.1%
Other KPB	187,501,467	243,131,973	261,640,105	253,115,826	310,104,465	242,601,288	-67,503,177	-21.8%
Total	477,672,841	579,731,431	612,509,443	624,492,744	734,762,089	605,387,922	-129,374,167	-17.6%
Annual Change		21.4%	5.7%	2.0%	17.7%	-17.6%		

Table 1.7

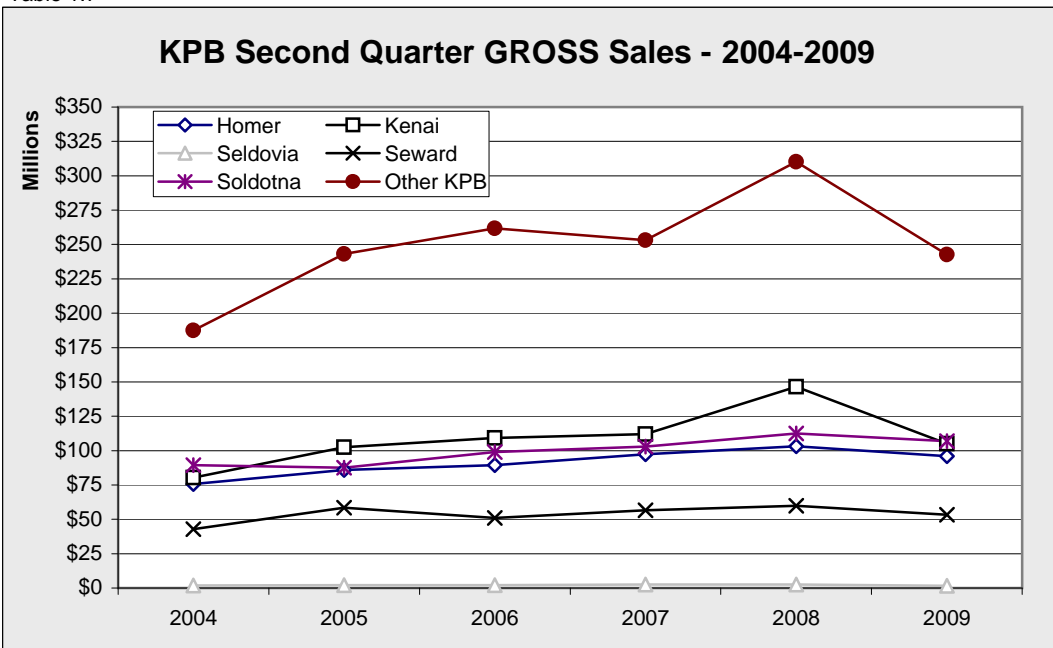

Chart 1.7

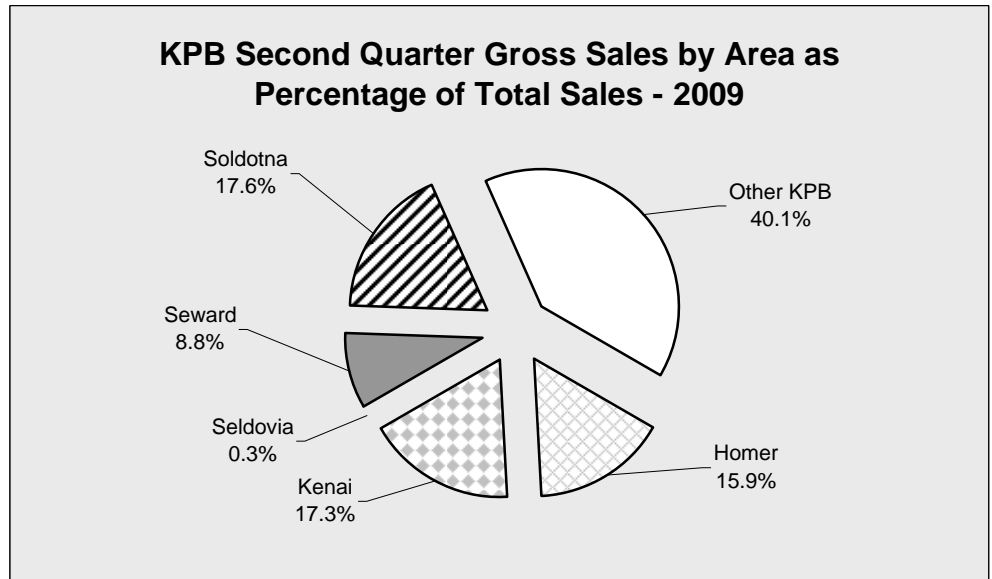

Chart 1.8

KPB Sales

KPB 2nd Quarter TAXABLE Sales by Area - 2004-2009 - in \$								
	2004	2005	2006	2007	2008	2009	Annual Amount Change	Annual Percent Change
Homer	39,648,524	41,201,861	43,368,152	47,168,234	48,871,596	40,262,341	-8,609,255	-17.6%
Kenai	36,263,788	37,518,001	41,096,929	49,096,842	44,860,208	46,504,382	1,644,174	3.7%
Seldovia	939,589	932,141	974,499	1,220,836	1,663,391	958,005	-705,386	-42.4%
Seward	22,991,903	25,309,646	26,596,215	30,040,462	30,194,399	26,440,658	-3,753,741	-12.4%
Soldotna	49,011,743	52,146,002	55,438,172	59,407,136	63,179,312	60,516,853	-2,662,459	-4.2%
Other KPB	58,428,144	63,286,728	68,388,554	75,169,557	82,366,645	57,431,593	-24,935,052	-30.3%
Total	207,283,691	220,394,379	235,862,521	262,103,067	271,135,551	232,113,832	-39,021,719	-14.4%
Annual Change		6.3%	7.0%	11.1%	3.4%	-14.4%		

Table 1.8 NOTE: Values are approximate due to non-taxables in different jurisdictions

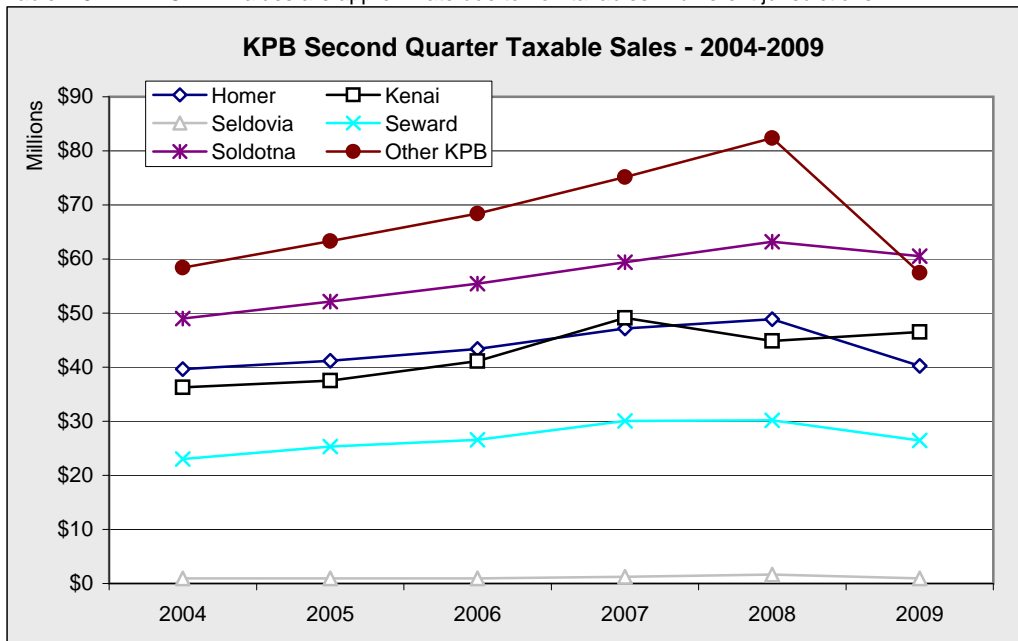

Chart 1.9

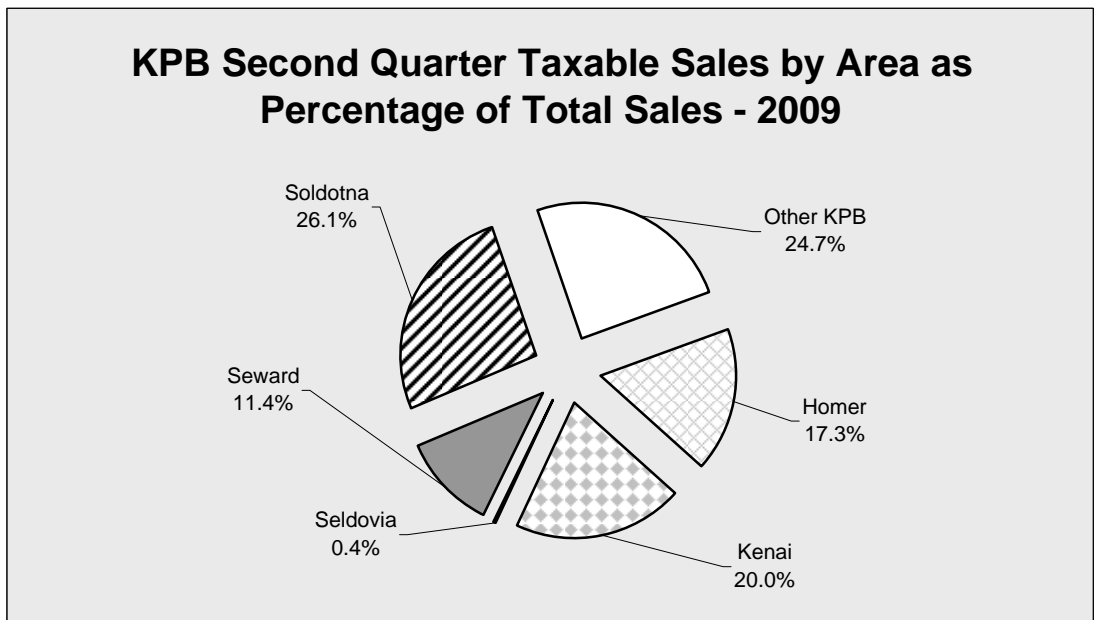

Chart 1.10

KPB Sales

KPB YTD June 30 GROSS Sales by Line of Business - 2004-2009 - in \$*								
Line of Business	2004	2005	2006	2007	2008	2009	Annual Amount Change	Annual Percentage Change
PROD	66,226,109	71,654,261	85,114,059	62,063,415	69,625,792	72,629,507	3,003,715	4.3%
SALES	263,998,213	281,740,395	298,000,632	309,150,477	357,134,618	347,925,351	-9,209,267	-2.6%
CONST	64,778,287	104,927,002	91,755,782	118,644,215	113,264,869	120,540,064	7,275,195	6.4%
PROP	34,584,081	35,737,396	40,105,986	40,961,439	44,237,205	42,628,371	-1,608,834	-3.6%
TOUR	53,226,161	71,256,345	76,263,998	78,376,016	55,325,694	40,386,635	-14,939,059	-27.0%
SERV	59,293,122	65,650,821	75,070,291	91,031,224	105,671,463	103,524,454	-2,147,009	-2.0%
PROF	24,044,329	24,446,442	28,301,191	30,315,016	33,269,905	31,564,021	-1,705,884	-5.1%
UTIL	43,415,425	50,558,233	59,408,300	68,096,554	65,471,552	89,740,755	24,269,203	37.1%
MGF	38,904,317	91,612,612	75,296,256	92,662,000	119,440,863	62,896,089	-56,544,774	-47.3%
TRAN	48,339,724	60,519,315	47,912,620	71,566,658	97,792,222	32,455,724	-65,336,498	-66.8%
WHSL	135,857,647	121,412,036	116,155,684	115,915,559	155,846,358	203,365,378	47,519,020	30.5%
GOV	5,912,371	6,414,701	6,797,071	7,197,103	7,365,043	7,795,814	430,771	5.8%
TOTAL	838,579,786	985,929,559	1,000,181,870	1,085,979,676	1,224,445,584	1,155,452,163	-68,993,421	-5.6%
Annual Change		17.6%	1.4%	8.6%	12.8%	-5.6%		

Table 1.9

* - For complete Line of Business (LOB) listing, see page 17.

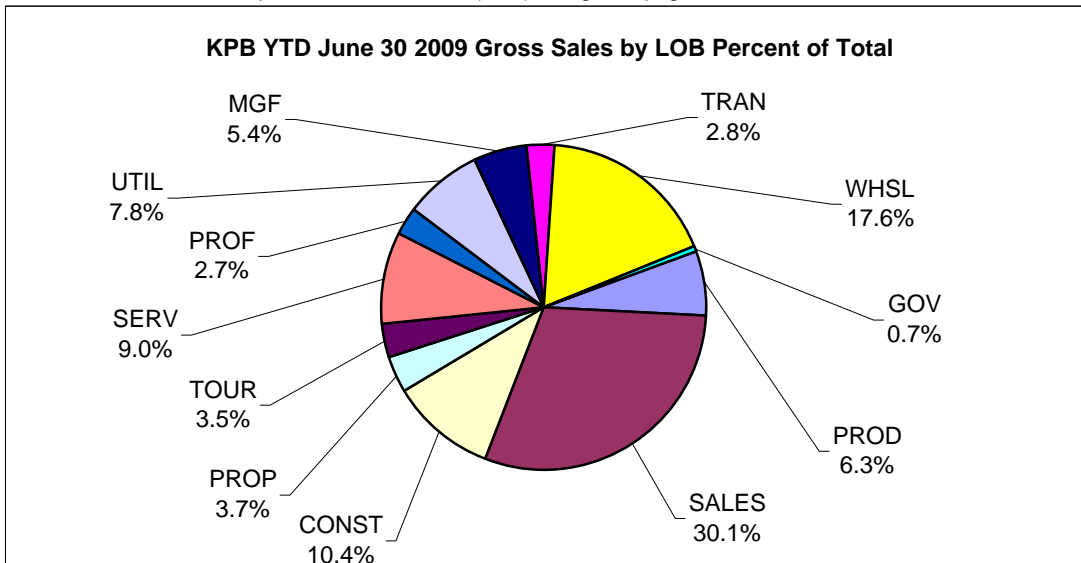

Chart 1.11

YTD June 30 Gross Sales Five Year Change by LOB				
	2004	2009	Value Change	Percent Change
PROD	66,226,109	72,629,507	6,403,398	9.7%
SALES	263,998,213	347,925,351	83,927,138	31.8%
CONST	64,778,287	120,540,064	55,761,777	86.1%
PROP	34,584,081	42,628,371	8,044,290	23.3%
TOUR	53,226,161	40,386,635	-12,839,526	-24.1%
SERV	59,293,122	103,524,454	44,231,332	74.6%
PROF	24,044,329	31,564,021	7,519,692	31.3%
UTIL	43,415,425	89,740,755	46,325,330	106.7%
MGF	38,904,317	62,896,089	23,991,772	61.7%
TRAN	48,339,724	32,455,724	-15,884,000	-32.9%
WHSL	135,857,647	203,365,378	67,507,731	49.7%
GOV	5,912,371	7,795,814	1,883,443	31.9%
TOTAL	838,579,786	1,155,452,163	316,872,377	37.8%

Table 1.10

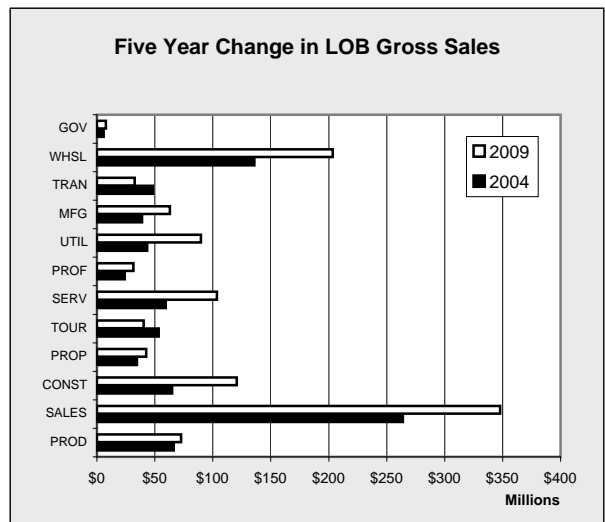

Chart 1.12

KPB Sales

KPB YTD June 30 TAXABLE Sales by Line of Business - 2004-2009 - in \$*

Line of Business	2004	2005	2006	2007	2008	2009	Annual Amount Change	Annual Percentage Change
PROD	2,828,671	2,744,954	2,688,361	2,934,386	3,225,616	3,704,427	478,811	14.8%
SALES	163,535,502	172,957,435	184,020,878	198,438,998	234,522,524	178,594,654	-55,927,870	-23.8%
CONST	5,132,786	4,855,863	4,935,590	5,209,380	5,456,865	4,845,058	-611,807	-11.2%
PROP	14,456,181	14,846,107	15,467,258	17,309,262	18,802,339	17,995,714	-806,625	-4.3%
TOUR	48,484,636	60,120,523	64,314,873	69,080,840	47,788,046	34,369,673	-13,418,373	-28.1%
SERV	36,684,655	37,934,178	40,158,408	44,803,937	49,849,731	50,771,314	921,583	1.8%
PROF	7,198,019	7,755,832	8,583,355	8,746,159	9,013,206	8,259,104	-754,102	-8.4%
UTIL	18,740,430	21,526,333	25,626,388	29,523,113	29,428,340	38,523,864	9,095,524	30.9%
MGF	2,658,186	2,851,670	3,719,277	4,051,062	3,313,094	3,057,183	-255,911	-7.7%
TRAN	11,731,042	1,032,570	1,367,923	1,216,583	1,571,257	1,855,948	284,691	18.1%
WHSL	30,352,307	32,639,447	36,046,560	37,606,755	40,331,098	33,593,471	-6,737,627	-16.7%
GOV	5,388,316	5,656,489	5,927,937	6,302,750	6,190,212	6,464,437	274,225	4.4%
TOTAL	347,190,731	364,921,401	392,856,808	425,223,225	449,492,328	382,034,847	-67,457,481	-15.0%
Annual Change		5.1%	7.7%	8.2%	5.7%	-15.0%		

Table 1.11

* - For complete Line of Business (LOB) listing, see page 17.

KPB YTD June 30 2009 Taxable Sales by LOB Percent of Total

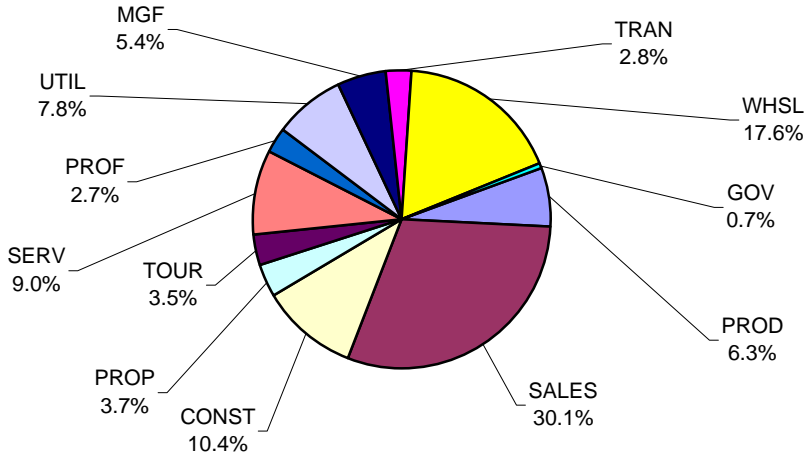

Chart 1.13

YTD June 30 Taxable Sales Five Year Change by LOB

	2004	2009	Value Change	Percent Change
PROD	2,828,671	3,704,427	875,756	31.0%
SALES	163,535,502	178,594,654	15,059,152	9.2%
CONST	5,132,786	4,845,058	-287,728	-5.6%
PROP	14,456,181	17,995,714	3,539,533	24.5%
TOUR	48,484,636	34,369,673	-14,114,963	-29.1%
SERV	36,684,655	50,771,314	14,086,659	38.4%
PROF	7,198,019	8,259,104	1,061,085	14.7%
UTIL	18,740,430	38,523,864	19,783,434	105.6%
MFG	2,658,186	3,057,183	398,997	15.0%
TRAN	11,731,042	1,855,948	-9,875,094	-84.2%
WHSL	30,352,307	33,593,471	3,241,164	10.7%
GOV	5,388,316	6,464,437	1,076,121	20.0%
TOTAL	347,190,731	382,034,847	34,844,116	10.0%

Table 1.12

Five Year Change in LOB Taxable Sales

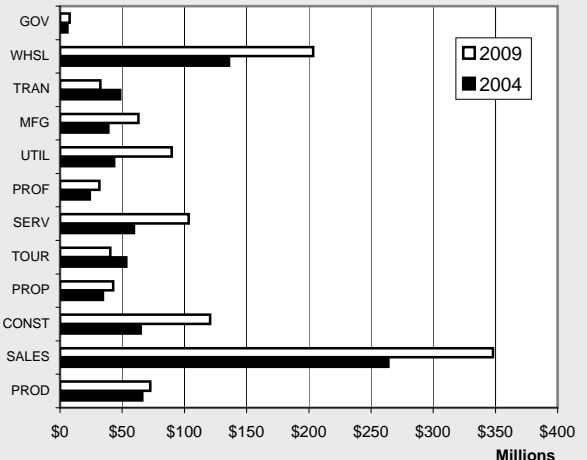

Chart 1.14

KPB Sales

KPB YTD June 30 GROSS Sales by Area - 2004-2009 - in \$								
	2004	2005	2006	2007	2008	2009	Annual Amount Change	Annual Percent Change
Homer	123,893,800	137,780,917	145,471,043	158,715,230	168,923,178	161,569,253	-7,353,925	-4.4%
Kenai	141,471,093	178,184,743	172,552,358	208,638,737	255,392,538	185,018,693	-70,373,845	-27.6%
Seldovia	3,376,717	3,382,269	3,687,931	4,013,317	4,107,916	2,913,617	-1,194,299	-29.1%
Seward	63,924,561	84,881,494	72,793,921	82,216,990	86,320,465	81,604,343	-4,716,122	-5.5%
Soldotna	159,239,797	153,588,723	171,469,965	182,225,631	201,994,070	186,914,707	-15,079,363	-7.5%
Other KPB	346,673,818	428,111,413	434,206,651	450,169,770	507,707,417	537,431,550	29,724,133	5.9%
Total	838,579,786	985,929,559	1,000,181,869	1,085,979,675	1,224,445,584	1,155,452,163	-68,993,421	-5.6%
Annual Change		17.6%	1.4%	8.6%	12.8%	-5.6%		

Table 1.13

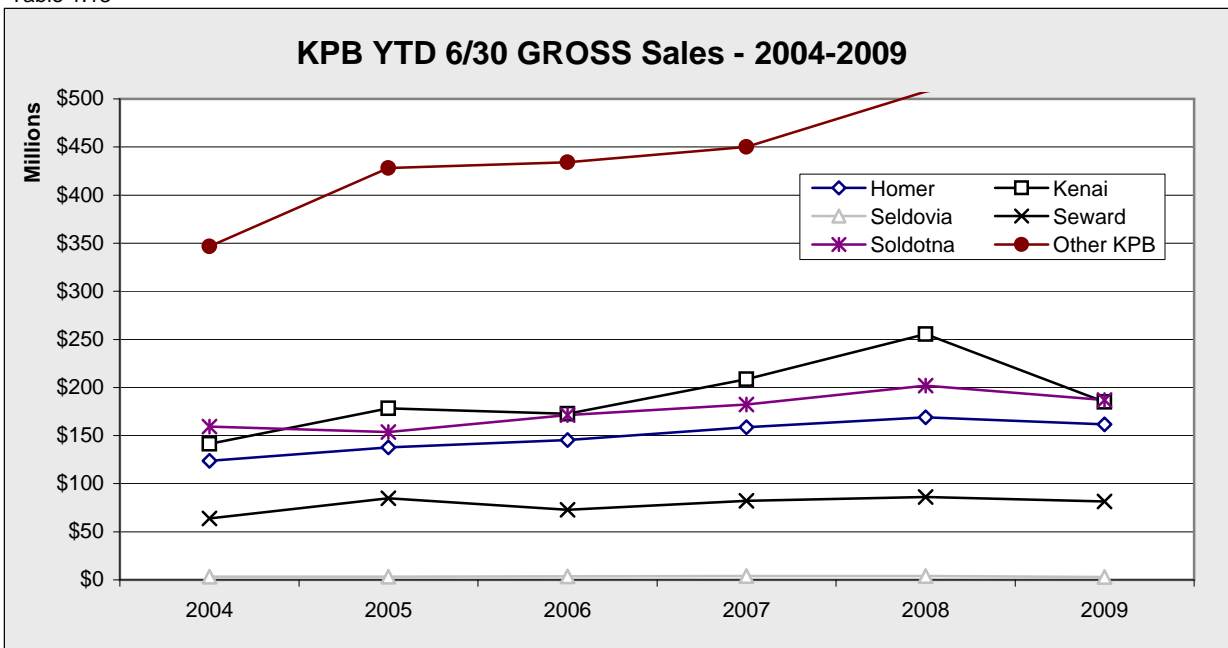

Chart 1.15

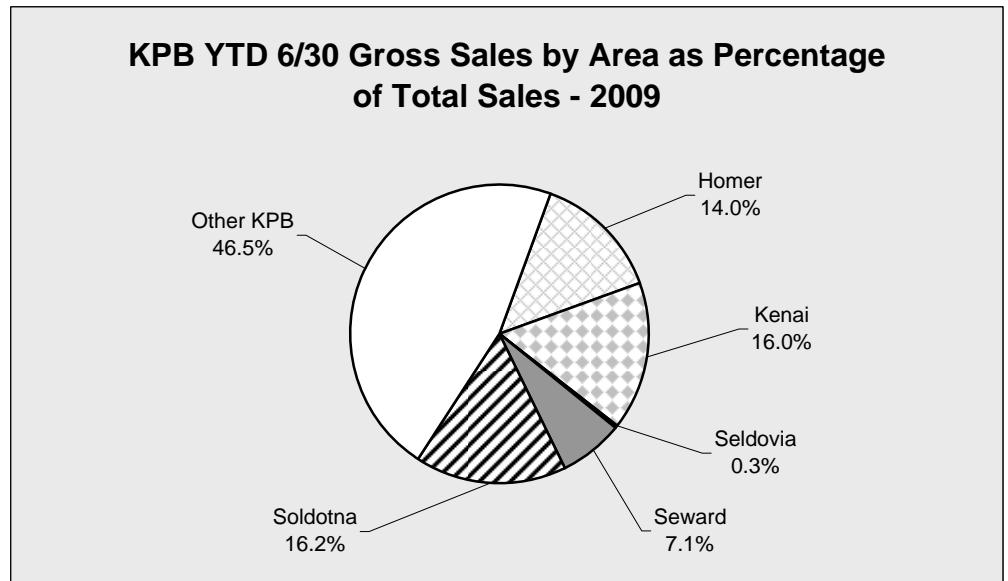

Chart 1.16

KPB Sales

KPB YTD June 30 TAXABLE Sales by Area - 2004-2009 - in \$

	2004	2005	2006	2007	2008	2009	Annual Amount Change	Annual Percent Change
Homer	63,473,444	65,538,552	69,085,778	74,422,793	77,894,513	62,851,835	-15,042,678	-19.3%
Kenai	65,820,279	67,126,134	73,487,144	77,410,635	81,059,602	83,862,290	2,802,688	3.5%
Seldovia	1,506,315	1,505,158	1,611,193	1,976,637	2,513,623	1,734,697	-778,926	-31.0%
Seward	32,488,011	35,403,984	36,766,877	40,910,360	41,534,052	36,776,773	-4,757,279	-11.5%
Soldotna	86,397,085	90,862,682	97,555,737	105,288,756	110,839,863	107,476,705	-3,363,158	-3.0%
Other KPB	97,505,597	104,484,891	114,350,081	125,214,044	135,650,675	100,243,993	-35,406,682	-26.1%
Total	347,190,731	364,921,401	392,856,810	425,223,225	449,492,328	392,946,293	-56,546,035	-12.6%
Annual Change		5.1%	7.7%	8.2%	5.7%	-12.6%		

Table 1.14

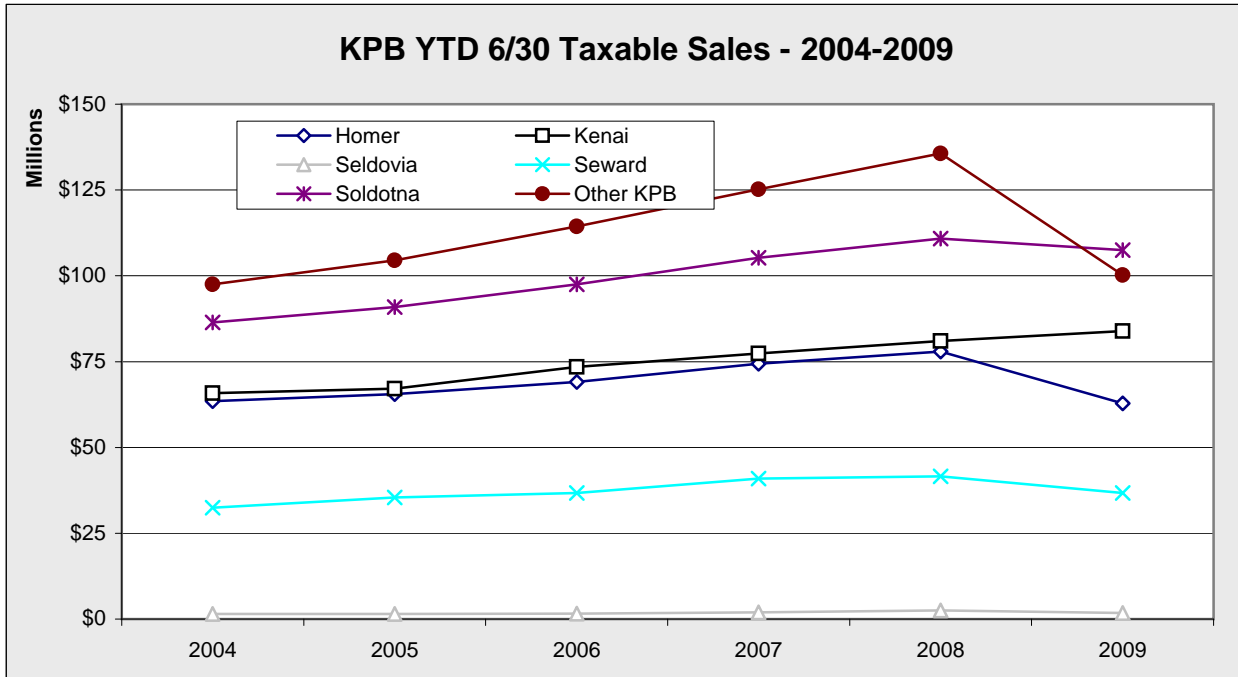

Chart 1.17

KPB YTD 6/30 Taxable Sales by Area as Percentage of Total Sales - 2009

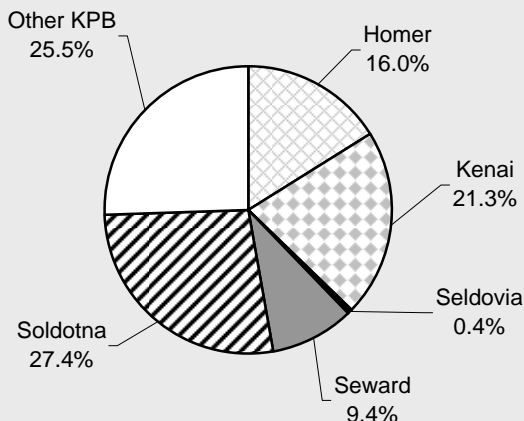

Chart 1.18

KPB Sales

KPB Annual GROSS Sales by Line of Business - 2003-2008 - in \$

	2003	2004	2005	2006	2007	2008	Annual Amount Change	Annual Percentage Change
PROD	182,434,266	250,770,234	233,126,367	219,043,152	198,852,957	220,624,624	21,771,667	10.9%
SALES	611,324,051	588,239,882	619,847,086	656,477,507	693,839,923	809,475,081	115,635,158	16.7%
CONST	239,118,564	222,665,293	291,866,412	365,247,770	311,077,123	310,212,011	-865,112	-0.3%
PROP	81,109,127	80,240,612	83,245,670	88,788,876	94,849,370	99,601,202	4,751,832	5.0%
TOUR	119,445,790	129,888,280	189,073,158	203,203,773	207,455,951	155,553,194	-51,902,757	-25.0%
SERV	115,631,552	137,231,314	141,771,433	160,342,954	197,785,739	223,400,639	25,614,900	13.0%
PROF	53,795,685	59,110,980	59,456,967	67,089,875	69,077,290	75,773,077	6,695,787	9.7%
UTIL	79,515,989	87,509,276	103,471,296	120,040,958	121,319,850	136,700,502	15,380,652	12.7%
MGF	140,566,505	179,632,875	249,940,567	178,665,554	196,516,138	262,581,508	66,065,370	33.6%
TRAN	79,449,807	122,937,678	116,543,212	126,841,197	165,070,503	219,186,646	54,116,143	32.8%
WHSL	205,406,411	459,495,602	468,209,106	499,886,669	533,714,308	629,233,693	95,519,385	17.9%
GOV	13,606,580	14,545,420	15,214,964	15,685,700	16,366,837	17,314,932	948,095	5.8%
TOTAL	1,921,404,327	2,332,267,446	2,571,766,238	2,701,313,985	2,805,925,989	3,159,657,109	353,731,120	12.6%
Annual Change		21.4%	10.3%	5.0%	3.9%	12.6%		

Table 1.15

See page 17 for complete listing of Lines of Business and their abbreviations.

KPB Total Annual Gross Sales by LOB 2008

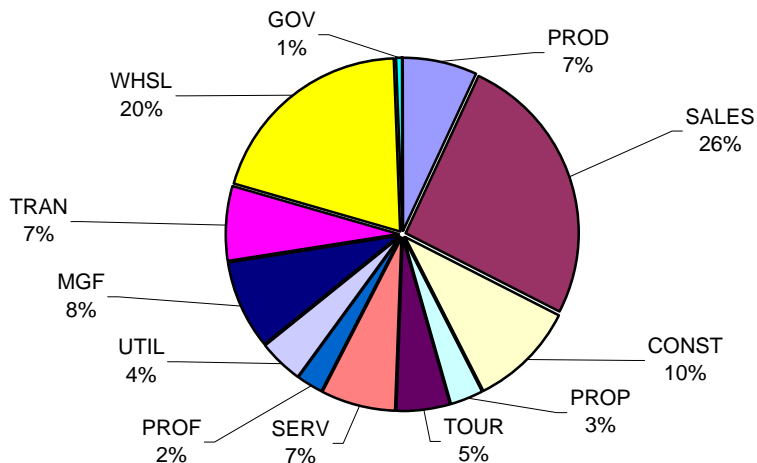

Chart 1.19

* The 2004 increase in wholesale goods may be due to a change in reporting requirements.

Gross Sales Five Year Change by LOB

	2003	2008	Percent Change	Value Change
PROD	182,434,266	220,624,624	20.9%	38,190,358
SALES	611,324,051	809,475,081	32.4%	198,151,030
CONST	239,118,564	310,212,011	29.7%	71,093,447
PROP	81,109,127	99,601,202	22.8%	18,492,075
TOUR	119,445,790	155,553,194	30.2%	36,107,404
SERV	115,631,552	223,400,639	93.2%	107,769,087
PROF	53,795,685	75,773,077	40.9%	21,977,392
UTIL	79,515,989	136,700,502	71.9%	57,184,513
MGF	140,566,505	262,581,508	86.8%	122,015,003
TRAN	79,449,807	219,186,646	175.9%	139,736,839
WHSL	205,406,411	629,233,693	206.3%	423,827,282
GOV	13,606,580	17,314,932	27.3%	3,708,352

Table 1.16

Five Year Change in Gross Sales by LOB

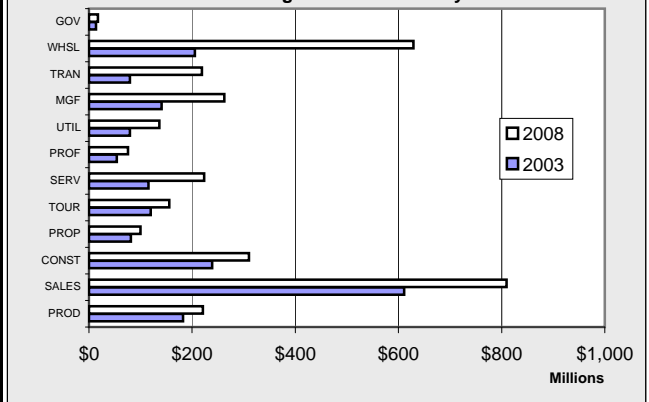

Chart 1.20

KPB Sales

KPB Annual Taxable Sales by Line of Business - 2003-2008 - in \$								
	2003	2004	2005	2006	2007	2008	Annual Amount Change	Annual Percentage Change
PROD	5,915,297	6,153,343	5,114,386	5,223,139	5,940,404	6,694,810	754,406	12.7%
SALES	361,428,352	368,413,713	390,887,293	417,851,705	452,696,833	538,927,936	86,231,103	19.0%
CONST	11,542,579	11,018,998	10,622,521	11,243,612	12,216,828	12,610,340	393,512	3.2%
PROP	31,039,985	31,406,151	32,691,193	34,622,371	39,227,330	41,708,890	2,481,560	6.3%
TOUR	109,495,576	116,978,812	153,201,396	163,802,197	180,512,107	132,133,153	-48,378,954	-26.8%
SERV	73,889,109	76,895,205	79,650,900	85,436,424	96,224,461	106,613,261	10,388,800	10.8%
PROF	13,359,981	13,613,821	14,917,338	16,151,644	17,153,213	17,695,101	541,888	3.2%
UTIL	35,022,919	36,146,549	41,032,308	48,825,218	53,435,892	56,985,954	3,550,062	6.6%
MGF	6,983,538	7,398,649	8,668,508	9,646,793	10,486,664	8,880,367	-1,606,297	-15.3%
TRAN	32,500,864	34,930,999	2,470,463	2,811,766	2,904,344	3,644,236	739,892	25.5%
WHSL	40,287,728	66,025,347	73,132,431	78,893,228	82,198,097	86,329,055	4,130,958	5.0%
GOV	11,696,775	12,288,242	13,034,058	13,433,539	14,194,814	14,631,227	436,413	3.1%
TOTAL	733,162,703	781,269,829	825,422,795	887,941,636	967,190,987	1,026,854,330	59,663,343	6.2%
Annual Change		6.6%	5.7%	7.6%	8.9%	6.2%		

Table 1.17

See page 17 for complete listing of Lines of Business and their abbreviations.

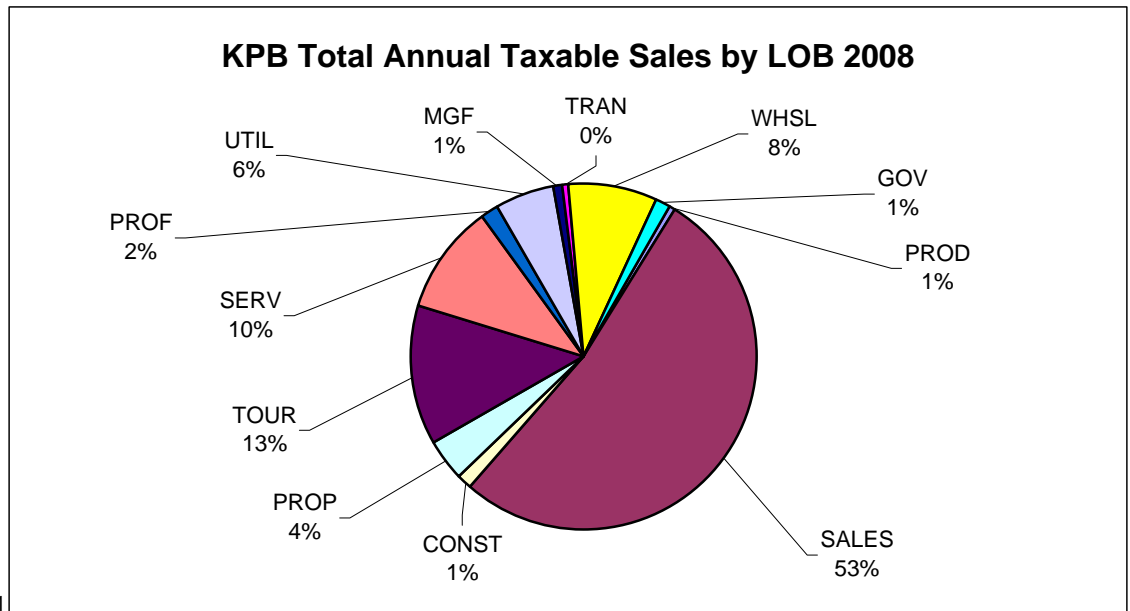

Chart 1.21

* The 2004 increase in wholesale goods may be due to a change in reporting requirements.

Taxable Sales Five Year Change by LOB				
	2003	2008	Percent Change	Value Change
PROD	6,576,292	6,294,070	-4.3%	-282,222
SALES	356,008,012	447,462,961	25.7%	91,454,949
CONST	11,241,233	12,094,817	7.6%	853,584
PROP	32,140,505	37,128,954	15.5%	4,988,449
TOUR	107,541,855	149,466,513	39.0%	41,924,658
SERV	75,988,405	95,821,995	26.1%	19,833,590
PROF	13,595,262	15,441,630	13.6%	1,846,368
UTIL	34,831,599	57,608,289	65.4%	22,776,690
MGF	7,047,802	9,838,378	39.6%	2,790,576
TRAN	32,535,661	37,640,268	15.7%	5,104,607
WHSL	35,421,522	81,865,128	131.1%	46,443,606
GOV	11,641,433	12,327,160	5.9%	685,727

Table 1.18

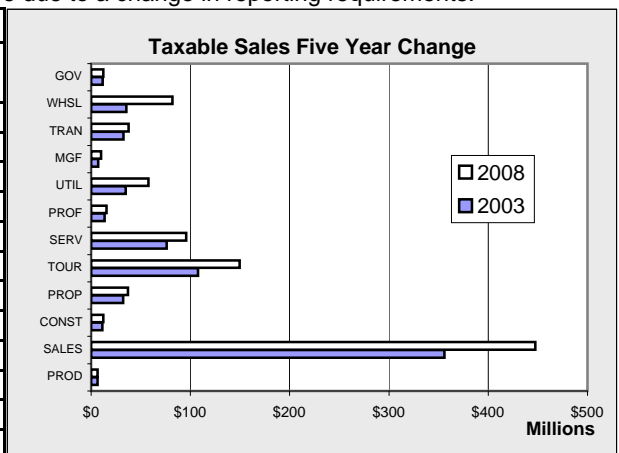

Chart 1.22

KPB Sales

KPB Annual GROSS Sales by Area - 2003-2008 - in \$

	2003	2004	2005	2006	2007	2008	Annual Amount Change	Annual Percentage Change
Homer	274,073,782	290,381,849	309,268,753	356,227,707	353,452,150	382,914,299	29,462,149	8.3%
Kenai	282,924,495	407,297,440	465,779,952	456,932,044	520,557,074	607,676,556	87,119,482	16.7%
Seldovia	7,259,554	8,329,831	6,871,279	7,564,723	9,495,815	8,530,781	-965,034	-10.2%
Seward	156,961,936	166,196,695	189,104,993	198,357,254	195,248,254	214,574,775	19,326,521	9.9%
Soldotna	337,906,000	361,255,515	396,033,463	432,855,181	429,295,387	465,405,888	36,110,501	8.4%
Other KPB	862,278,560	1,098,806,116	1,204,707,798	1,249,377,076	1,297,877,309	1,480,554,810	182,677,501	14.1%
Total	1,921,404,327	2,332,267,446	2,571,766,238	2,701,313,985	2,805,925,989	3,159,657,109	353,731,120	12.6%
Annual Change		21.4%	10.3%	5.0%	3.9%	12.6%		

Table 1.19

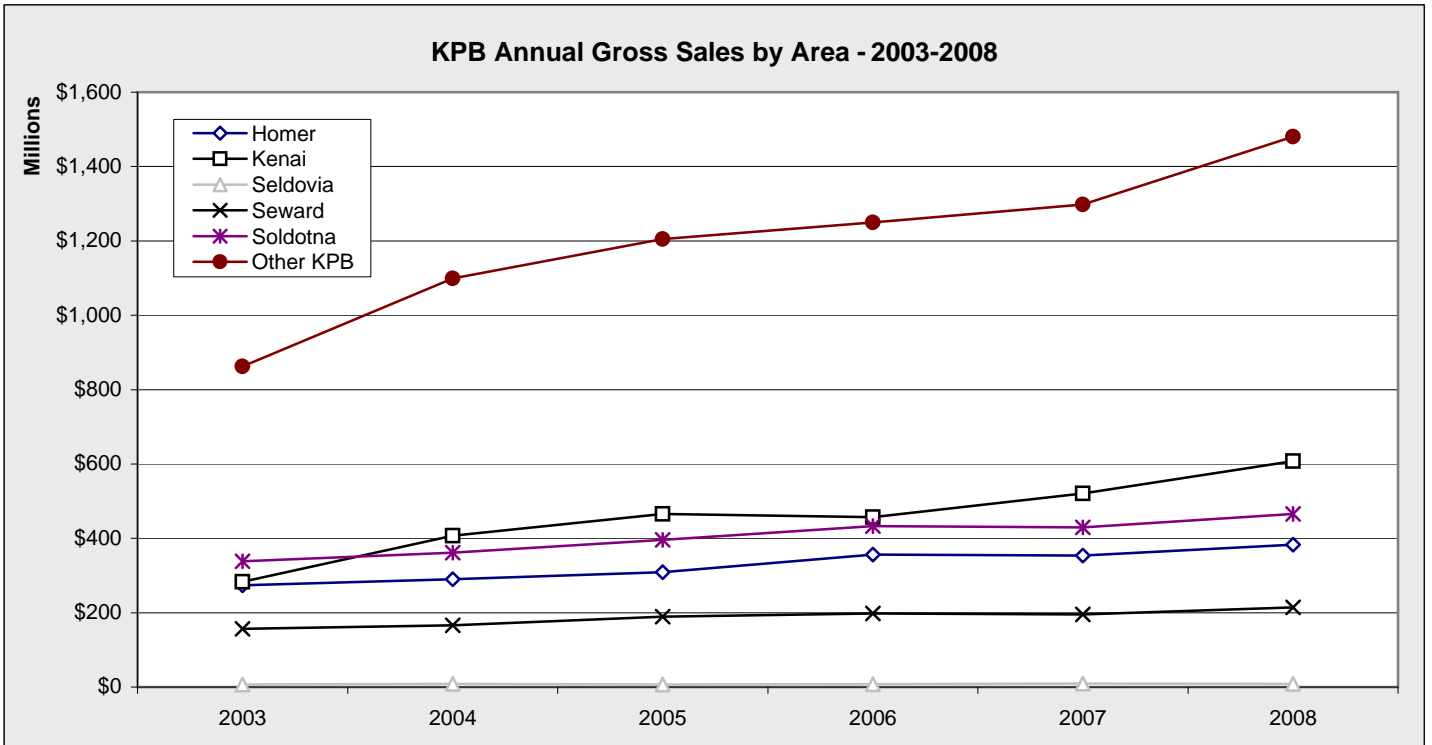

Chart 1.23

Annual Gross Sales Five Year Change by Area				
	2003	2008	Value Change	Percent Change
Homer	274,073,782	382,914,299	108,840,517	39.7%
Kenai	282,924,495	607,676,556	324,752,061	114.8%
Seldovia	7,259,554	8,530,781	1,271,227	17.5%
Seward	156,961,936	214,574,775	57,612,839	36.7%
Soldotna	337,906,000	465,405,888	127,499,888	37.7%
Other	862,278,560	1,480,554,810	618,276,250	71.7%
TOTAL	1,921,404,327	3,159,657,109	1,238,252,782	64.4%

Table 1.20

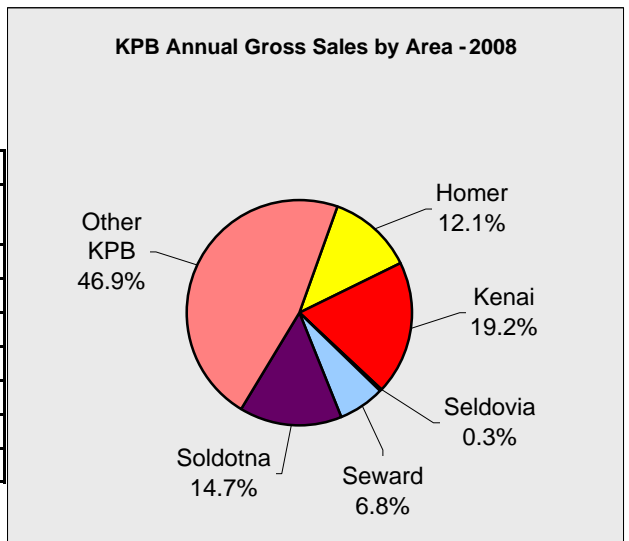

Chart 1.24

KPB Sales

KPB Annual TAXABLE Sales by Area - 2003-2008- in \$

	2003	2004	2005	2006	2007	2008	Annual Amount Change	Annual Percentage Change
Homer	131,729,196	139,933,678	144,757,649	153,385,392	166,500,949	173,010,794	6,509,845	3.9%
Kenai	121,356,795	139,399,127	145,536,054	156,640,595	167,077,378	175,891,484	8,814,106	5.3%
Seldovia	3,376,944	3,386,312	3,380,980	3,671,079	4,317,728	5,004,876	687,148	15.9%
Seward	76,348,733	79,948,305	87,749,003	91,089,954	102,255,726	105,003,769	2,748,043	2.7%
Soldotna	190,627,772	200,056,184	211,210,444	227,545,027	243,495,221	261,094,783	17,599,562	7.2%
Other KPB	209,723,263	218,546,223	232,788,665	255,609,589	283,543,985	306,848,624	23,304,639	8.2%
Total	733,162,703	781,269,829	825,422,795	887,941,636	967,190,987	1,026,854,330	59,663,343	6.2%
Annual Change		6.6%	5.7%	7.6%	8.9%	6.2%		

Table 1.21

KPB Annual Taxable Sales by Area - 2003-2008

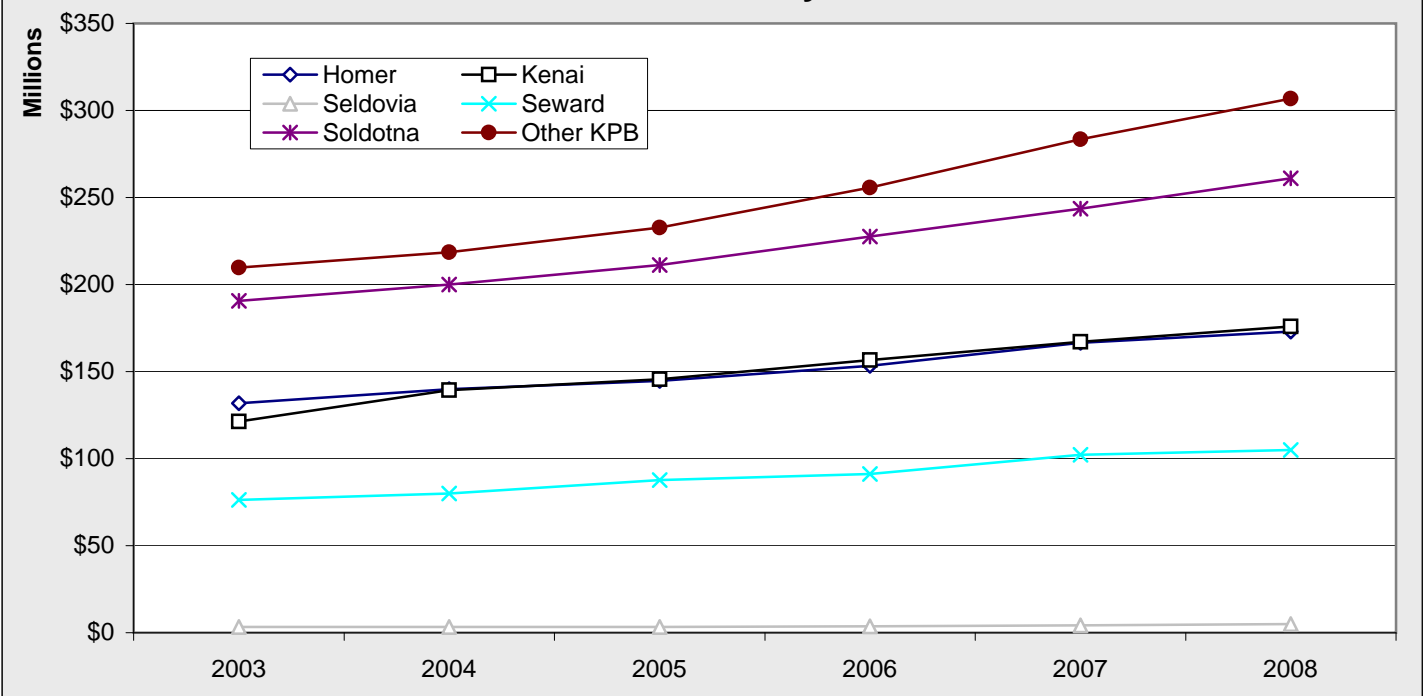

Chart 1.25

Annual Taxable Sales Five Year Change by Area

	2003	2008	Value Change	Percent Change
Homer	131,729,196	173,010,794	41,281,598	31.3%
Kenai	121,356,795	175,891,484	54,534,689	44.9%
Seldovia	3,376,944	5,004,876	1,627,932	48.2%
Seward	76,348,733	105,003,769	28,655,036	37.5%
Soldotna	190,627,772	261,094,783	70,467,011	37.0%
Other	209,723,263	306,848,624	97,125,361	46.3%
TOTAL	733,162,703	1,026,854,330	293,691,627	40.1%

Table 1.22

Annual Taxable Sales By Area 2008

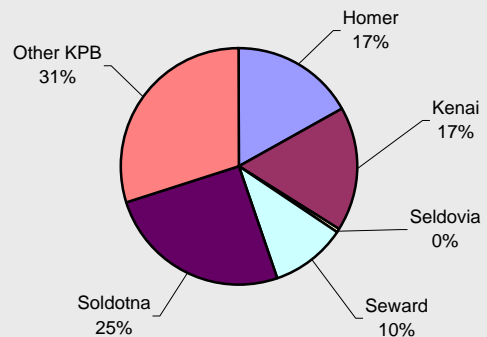

Chart 1.26

KPB Sales

KPB Annual GROSS Sales by LOB by Quarter - 2008- in \$					
LOB	1st Quarter	2nd Quarter	3rd Quarter	4th Quarter	Total
PROD	28,399,783	41,226,009	51,993,400	99,005,432	220,624,624
SALES	147,230,051	209,904,567	261,798,968	190,541,495	809,475,081
CONST	46,451,878	66,812,991	104,165,596	92,781,546	310,212,011
PROP	19,005,545	25,231,660	30,162,850	25,201,147	99,601,202
TOUR	8,149,740	47,175,954	89,978,836	10,248,664	155,553,194
SERV	43,518,244	62,153,219	65,159,602	52,569,574	223,400,639
PROF	15,036,479	18,233,426	19,108,411	23,394,761	75,773,077
UTIL	35,696,808	29,774,744	30,780,619	40,448,331	136,700,502
MFG	38,544,973	80,895,890	104,586,640	38,554,005	262,581,508
TRAN	40,015,969	57,776,253	69,090,301	52,304,123	219,186,646
WHSL	64,212,311	91,634,047	104,580,326	368,807,009	629,233,693
GOV	3,421,715	3,943,328	5,690,831	4,259,058	17,314,932
TOTAL	489,683,496	734,762,088	937,096,380	998,115,145	3,159,657,109

Table 1.23

KPB Annual GROSS Sales by Area by Quarter - 2008- in \$					
	1st Quarter	2nd Quarter	3rd Quarter	4th Quarter	Total
Homer	65,708,118	103,215,060	125,955,296	88,035,825	382,914,299
Kenai	108,812,075	146,580,463	182,488,483	169,795,535	607,676,556
Seldovia	1,516,251	2,591,665	2,347,161	2,075,704	8,530,781
Seward	26,506,069	59,814,396	89,445,765	38,808,545	214,574,775
Soldotna	89,538,030	112,456,040	146,420,303	116,991,515	465,405,888
Other	197,602,952	310,104,465	390,439,372	582,408,021	1,480,554,810
Total	489,683,495	734,762,089	937,096,380	998,115,145	3,159,657,109

Table 1.24

KPB Annual TAXABLE Sales by LOB by Quarter - 2008 - in \$					
LOB	1st Quarter	2nd Quarter	3rd Quarter	4th Quarter	Total
PROD	1,008,753	2,216,863	1,748,758	1,720,436	6,694,810
SALES	95,601,390	138,921,134	185,402,282	119,003,130	538,927,936
CONST	2,374,653	3,082,212	3,914,197	3,239,278	12,610,340
PROP	7,918,408	10,883,931	13,305,391	9,601,160	41,708,890
TOUR	6,889,798	40,898,248	77,011,482	7,333,625	132,133,153
SERV	22,343,938	27,505,793	31,168,849	25,594,681	106,613,261
PROF	4,269,130	4,744,076	4,688,193	3,993,702	17,695,101
UTIL	16,634,798	12,793,542	11,107,978	16,449,636	56,985,954
MFG	961,058	2,352,036	4,211,685	1,355,588	8,880,367
TRAN	562,731	1,008,526	1,277,653	795,326	3,644,236
WHSL	17,059,910	23,271,188	26,815,958	19,181,999	86,329,055
GOV	2,732,211	3,458,001	4,806,976	3,634,039	14,631,227
TOTAL	178,356,778	271,135,550	365,459,402	211,902,600	1,026,854,330

Table 1.25

KPB Annual TAXABLE Sales by Area by Quarter - 2008 - in \$					
	1st Quarter	2nd Quarter	3rd Quarter	4th Quarter	Total
Homer	29,022,917	48,871,596	62,341,184	32,775,097	173,010,794
Kenai	36,199,394	44,860,208	52,374,003	42,457,879	175,891,484
Seldovia	850,232	1,663,391	1,634,020	857,233	5,004,876
Seward	11,339,653	30,194,399	50,389,355	13,080,362	105,003,769
Soldotna	47,660,551	63,179,312	90,667,066	59,587,854	261,094,783
Other	53,284,030	82,366,645	108,053,774	63,144,175	306,848,624
Total	178,356,777	271,135,551	365,459,402	211,902,600	1,026,854,330

Table 1.26

KPB Sales

KPB Annual GROSS Sales by LOB by Quarter - 2007 - in \$					
LOB	1st Quarter	2nd Quarter	3rd Quarter	4th Quarter	Total
PROD	24,974,260	37,089,155	43,860,460	92,929,082	198,852,957
SALES	127,448,205	181,702,272	218,992,332	165,697,114	693,839,923
CONST	47,528,741	71,115,474	96,207,346	96,225,562	311,077,123
PROP	17,951,988	23,009,451	27,572,825	26,315,106	94,849,370
TOUR	18,936,404	59,439,612	108,920,809	20,159,126	207,455,951
SERV	37,198,517	53,832,707	58,113,534	48,640,981	197,785,739
PROF	14,926,273	15,388,743	16,507,916	22,254,358	69,077,290
UTIL	37,984,202	30,112,352	20,940,611	32,282,685	121,319,850
MFG	45,887,281	46,774,719	85,026,281	18,827,857	196,516,138
TRAN	36,805,498	34,761,160	50,920,772	42,583,073	165,070,503
WHSL	48,617,298	67,298,261	83,966,334	333,832,415	533,714,308
GOV	3,228,263	3,968,840	5,039,313	4,130,421	16,366,837
TOTAL	461,486,930	624,492,746	816,068,533	903,877,780	2,805,925,989

Table 1.27

KPB Annual GROSS Sales by Area by Quarter - 2007 - in \$					
	1st Quarter	2nd Quarter	3rd Quarter	4th Quarter	Total
Homer	61,424,512	97,290,718	113,727,381	81,009,539	353,452,150
Kenai	96,678,364	111,960,372	152,995,834	158,922,503	520,557,073
Seldovia	1,462,524	2,550,793	2,130,764	3,351,734	9,495,815
Seward	25,608,135	56,608,855	78,382,897	34,648,367	195,248,254
Soldotna	79,259,451	102,966,182	130,199,944	116,869,811	429,295,388
Other	197,053,944	253,115,826	338,631,713	509,075,826	1,297,877,309
Total	461,486,930	624,492,746	816,068,533	903,877,780	2,805,925,989

Table 1.28

KPB Annual TAXABLE Sales by LOB by Quarter - 2007- in \$					
LOB	1st Quarter	2nd Quarter	3rd Quarter	4th Quarter	Total
PROD	894,819	2,039,567	1,570,128	1,435,890	5,940,404
SALES	80,780,970	117,658,028	149,604,085	104,653,750	452,696,833
CONST	2,174,970	3,034,410	3,698,378	3,309,070	12,216,828
PROP	7,356,863	9,952,399	12,274,904	9,643,164	39,227,330
TOUR	16,073,170	53,007,670	94,466,360	16,964,907	180,512,107
SERV	19,244,573	25,559,364	28,089,546	23,330,978	96,224,461
PROF	4,134,921	4,611,238	4,388,635	4,018,419	17,153,213
UTIL	17,578,615	11,944,498	10,474,300	13,438,479	53,435,892
MFG	1233175	2,817,887	4,774,431	1,661,171	10,486,664
TRAN	425,345	791,238	900,948	786,813	2,904,344
WHSL	16,366,742	21,240,013	24,090,040	20,501,302	82,198,097
GOV	2,855,994	3,446,756	4,347,718	3,544,346	14,194,814
TOTAL	169,120,157	256,103,068	338,679,473	203,288,289	967,190,987

Table 1.29

KPB Annual TAXABLE Sales by Area by Quarter - 2007 - in \$					
	1st Quarter	2nd Quarter	3rd Quarter	4th Quarter	Total
Homer	27,254,559	47,168,234	59,366,059	32,712,097	166,500,949
Kenai	34,313,793	43,096,842	48,556,382	41,110,361	167,077,378
Seldovia	755,801	1,220,837	1,508,876	832,215	4,317,729
Seward	10,869,897	30,040,462	48,661,876	12,683,490	102,255,725
Soldotna	45,881,620	59,407,136	80,093,167	58,113,298	243,495,221
Other	50,044,487	75,169,557	100,493,113	57,836,828	283,543,985
Total	169,120,157	256,103,068	338,679,473	203,288,289	967,190,987

Table 1.30

KPB Sales

KPB Annual GROSS Sales by LOB by Quarter - 2006 - in \$					
LOB	1st Quarter	2nd Quarter	3rd Quarter	4th Quarter	Total
PROD	41,274,840	43,839,219	62,118,237	71,810,856	219,043,152
SALES	119,035,596	178,965,036	206,143,237	152,333,638	656,477,507
CONST	31,974,205	59,781,577	97,217,621	176,274,367	365,247,770
PROP	17,365,603	22,740,383	25,835,246	22,847,644	88,788,876
TOUR	17,398,131	58,865,867	106,305,678	20,634,097	203,203,773
SERV	32,231,969	42,838,322	43,893,954	41,378,709	160,342,954
PROF	14,136,142	14,165,049	15,548,787	23,239,897	67,089,875
UTIL	32,447,128	26,961,172	26,505,508	34,127,150	120,040,958
MFG	20,273,690	55,022,566	68,436,833	34,932,465	178,665,554
TRAN	10,675,096	37,237,524	40,847,624	38,080,953	126,841,197
WHSL	47,733,746	68,421,938	77,931,201	305,799,784	499,886,669
GOV	3,126,281	3,670,790	4,731,516	4,157,113	15,685,700
TOTAL	387,672,427	612,509,443	775,515,442	925,616,673	2,701,313,985

Table 1.31

KPB Annual GROSS Sales by Area by Quarter - 2006 - in \$					
	1st Quarter	2nd Quarter	3rd Quarter	4th Quarter	Total
Homer	56,156,763	89,314,280	118,463,107	92,293,557	356,227,707
Kenai	63,273,640	109,278,718	121,537,938	162,841,748	456,932,044
Seldovia	1,517,120	2,170,811	2,529,588	1,347,204	7,564,723
Seward	21,701,206	51,092,715	75,592,879	49,970,453	198,357,253
Soldotna	72,457,152	99,012,814	121,167,794	140,217,422	432,855,182
Other	172,566,546	261,640,105	336,224,136	478,946,289	1,249,377,076
Total	387,672,427	612,509,443	775,515,442	925,616,673	2,701,313,985

Table 1.32

KPB Annual TAXABLE Sales by LOB by Quarter - 2006 - in \$					
LOB	1st Quarter	2nd Quarter	3rd Quarter	4th Quarter	Total
PROD	865,170	1,823,191	1,329,079	1,205,699	5,223,139
SALES	74,586,992	109,433,886	137,489,167	96,341,660	417,851,705
CONST	1,990,771	2,944,819	3,306,229	3,001,793	11,243,612
PROP	6,936,051	8,531,207	10,729,981	8,425,132	34,622,371
TOUR	15,899,091	48,415,782	81,959,541	17,527,783	163,802,197
SERV	18,046,491	22,111,917	24,398,224	20,879,792	85,436,424
PROF	4,046,431	4,536,924	3,964,046	3,604,243	16,151,644
UTIL	14,962,505	10,663,883	9,087,067	14,111,763	48,825,218
MFG	1,272,729	2,446,548	4,224,455	1,703,061	9,646,793
TRAN	478,235	889,688	912,143	531,700	2,811,766
WHSL	15,226,750	20,819,811	24,110,681	18,735,987	78,893,229
GOV	2,683,072	3,244,865	4,214,700	3,290,902	13,433,539
TOTAL	156,994,288	235,862,521	305,725,313	189,359,515	887,941,637

Table 1.33

KPB Annual TAXABLE Sales by Area by Quarter - 2005 - in \$					
	1st Quarter	2nd Quarter	3rd Quarter	4th Quarter	Total
Homer	25,717,626	43,368,152	53,836,629	30,462,985	153,385,392
Kenai	32,390,215	41,096,929	45,216,664	37,936,787	156,640,595
Seldovia	636,694	974,499	1,348,064	711,822	3,671,079
Seward	10,170,662	26,596,215	42,438,197	11,884,880	91,089,954
Soldotna	42,117,565	55,438,172	75,557,722	54,431,570	227,545,029
Other	45,961,526	68,388,554	87,328,037	53,931,471	255,609,588
Total	156,994,288	235,862,521	305,725,313	189,359,515	887,941,637

Table 1.34

KPB Sales

KPB Annual GROSS Sales by LOB by Quarter - 2005 - in \$					
LOB	1st Quarter	2nd Quarter	3rd Quarter	4th Quarter	Total
PROD	38,011,490	33,642,771	41,473,586	119,998,520	233,126,367
SALES	113,648,812	168,091,583	195,355,030	142,751,661	619,847,086
CONST	38,483,190	66,443,812	75,663,732	111,275,678	291,866,412
PROP	15,005,828	20,731,568	23,663,215	23,845,059	83,245,670
TOUR	16,292,977	54,963,368	98,426,275	19,390,538	189,073,158
SERV	28,623,999	37,026,822	39,585,448	36,535,164	141,771,433
PROF	12,543,218	11,903,224	13,373,844	21,636,681	59,456,967
UTIL	27,279,722	23,278,511	26,333,258	26,579,805	103,471,296
MFG	33,061,008	58,551,604	116,074,442	42,253,513	249,940,567
TRAN	24,457,384	36,061,931	17,881,873	38,142,024	116,543,212
WHSL	55,790,599	65,621,437	74,859,753	271,937,317	468,209,106
GOV	2,999,901	3,414,800	4,874,984	3,925,279	15,214,964
TOTAL	406,198,128	579,731,431	727,565,440	858,271,239	2,571,766,238

Table 1.35

KPB Annual GROSS Sales by Area by Quarter - 2005 - in \$					
	1st Quarter	2nd Quarter	3rd Quarter	4th Quarter	Total
Homer	51,885,093	85,895,824	100,977,789	70,510,047	309,268,753
Kenai	75,641,521	102,543,222	112,340,508	175,254,701	465,779,952
Seldovia	1,261,735	2,120,534	2,275,335	1,213,675	6,871,279
Seward	26,472,186	58,409,308	70,009,818	34,213,681	189,104,993
Soldotna	65,958,153	87,630,570	113,939,869	128,504,871	396,033,463
Other	184,979,440	243,131,973	328,022,121	448,574,264	1,204,707,798
Total	406,198,128	579,731,431	727,565,440	858,271,239	2,571,766,238

Table 1.36

KPB Annual TAXABLE Sales by LOB by Quarter - 2005 - in \$					
LOB	1st Quarter	2nd Quarter	3rd Quarter	4th Quarter	Total
PROD	954,695	1,790,259	1,187,436	1,181,996	5,114,386
SALES	69,744,866	103,212,569	128,395,123	89,534,735	390,887,293
CONST	1,947,107	2,908,756	3,100,842	2,665,816	10,622,521
PROP	6,582,621	8,105,498	10,052,804	7,663,204	32,404,127
TOUR	14,848,579	45,271,944	76,420,240	16,660,633	153,201,396
SERV	17,476,467	21,229,591	22,737,237	19,737,155	81,180,450
PROF	3,481,938	3,660,002	3,497,629	3,035,285	13,674,854
UTIL	12,169,072	9,357,261	8,389,891	11,116,084	41,032,308
MFG	816,272	2,035,398	3,987,892	1,828,946	8,668,508
TRAN	386,935	645,635	768,202	669,691	2,470,463
WHSL	13,543,440	19,096,007	22,162,375	18,330,609	73,132,431
GOV	2,575,030	3,081,459	4,282,656	3,094,913	13,034,058
TOTAL	144,527,022	220,394,379	284,982,327	175,519,067	825,422,795

Table 1.37

KPB Annual TAXABLE Sales by Area by Quarter - 2005 - in \$					
	1st Quarter	2nd Quarter	3rd Quarter	4th Quarter	Total
Homer	24,336,691	41,201,861	50,641,860	28,577,237	144,757,649
Kenai	29,608,133	37,518,001	42,697,902	35,712,018	145,536,054
Seldovia	573,017	932,141	1,215,676	660,146	3,380,980
Seward	10,094,338	25,309,646	40,943,244	11,401,775	87,749,003
Soldotna	38,716,680	52,146,002	69,952,376	50,395,386	211,210,444
Other	41,198,163	63,286,728	79,531,269	48,772,505	232,788,665
Total	144,527,022	220,394,379	284,982,327	175,519,067	825,422,795

Table 1.38

KPB Construction Permits

Construction Permitting

Construction permits are not required within the KPB except within the incorporated cities of Homer, Kenai, Seldovia, Seward and Soldotna; therefore, data reported in this document does not include all KPB construction activity. It does, however, provide city trends. Permit categories include Residential New (RN), Residential Alteration/Addition (RA), Commercial New (CN) and Commercial Alteration/Addition (CA). Individual cities may have other categories, but in an effort to provide consistent categories across the KPB, those categories have been combined into one of the four. Borough-wide new residential construction per the KPB Assessing Department is presented in the annual statistical report, *Situations and Prospects*. Homer, Kenai, Seldovia and Soldotna permit activity has been recorded since 1986 but Seward did not require permits until 1988.

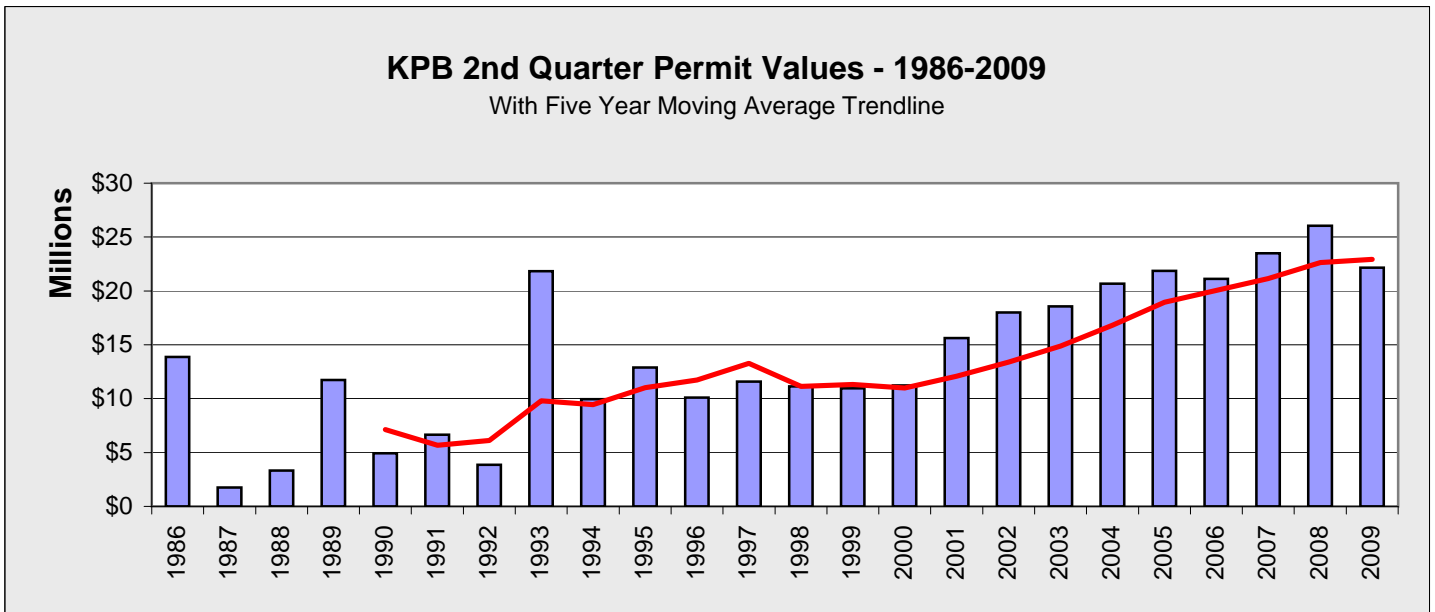

Chart 1.26

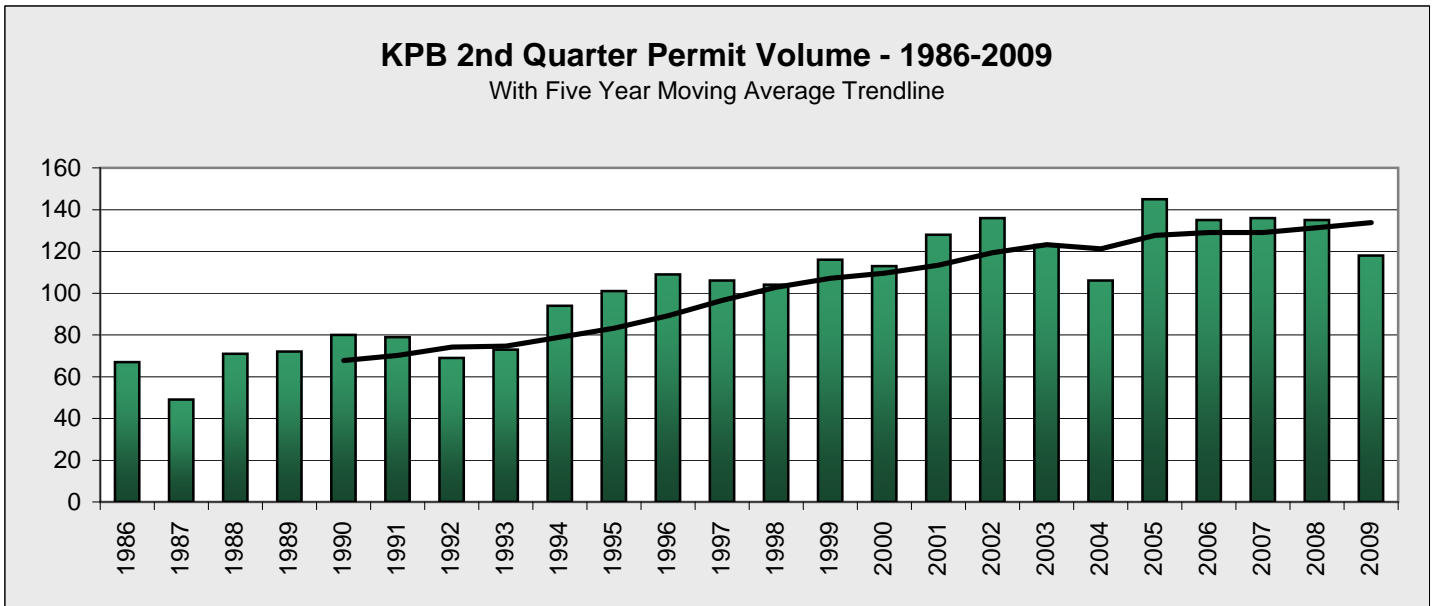

Chart 1.27

KPB Construction Permits

KPB 2nd Quarter Permit Values by Area - 2003-2009 - in \$								
	2003	2004	2005	2006	2007	2008	2009	Annual Change
Homer	7,929,500	7,433,711	11,246,000	7,467,100	7,292,001	16,651,000	2,390,500	-85.6%
Kenai	2,728,350	1,897,400	2,557,300	4,157,100	6,168,100	18,980,900	3,213,270	-83.1%
Seldovia	0	156,200	466,000	87,000	267,000	7,500	307,500	4000.0%
Seward	3,672,010	7,433,900	758,540	2,184,672	1,888,287	1,844,464	10,958,799	494.1%
Soldotna	4,233,924	3,748,573	6,832,235	7,231,328	7,877,205	5,212,121	5,294,876	1.6%
Total	18,563,784	20,669,784	21,860,075	21,127,200	23,492,593	42,695,985	22,164,945	-48.1%
Annual Change		11.3%	5.8%	-3.4%	11.2%	81.7%	-48.1%	

Table 1.39

KPB 2nd Quarter Permit Volume by Area - 2003-2009								
	2003	2004	2005	2006	2007	2008	2009	Annual Change
Homer	34	26	47	39	40	31	19	-38.7%
Kenai	40	30	33	42	43	45	31	-31.1%
Seldovia	0	3	6	6	9	2	4	100.0%
Seward	13	21	19	23	11	12	22	83.3%
Soldotna	36	26	40	25	33	37	42	13.5%
Total	123	106	145	135	136	127	118	-7.1%
Annual Change		-13.8%	36.8%	-6.9%	0.7%	-6.6%	-7.1%	

Table 1.40

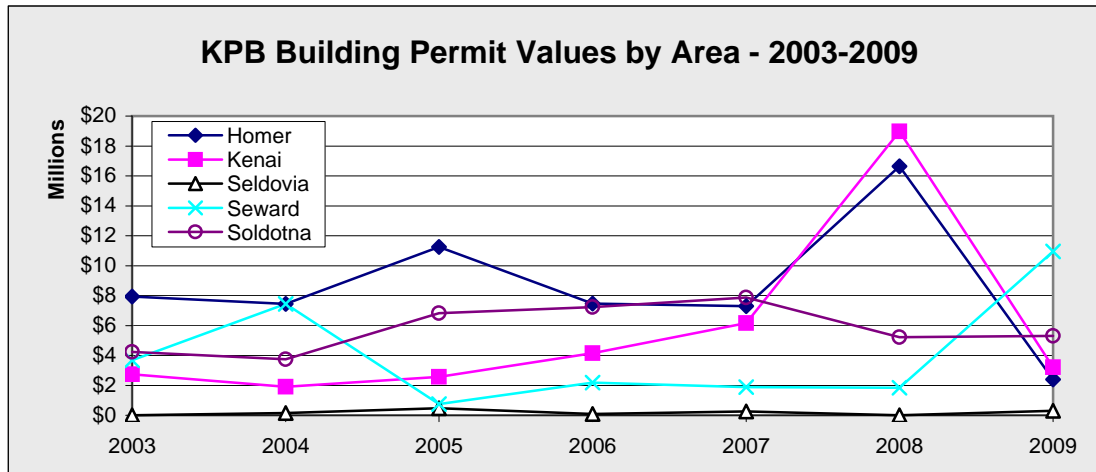

Chart 1.28

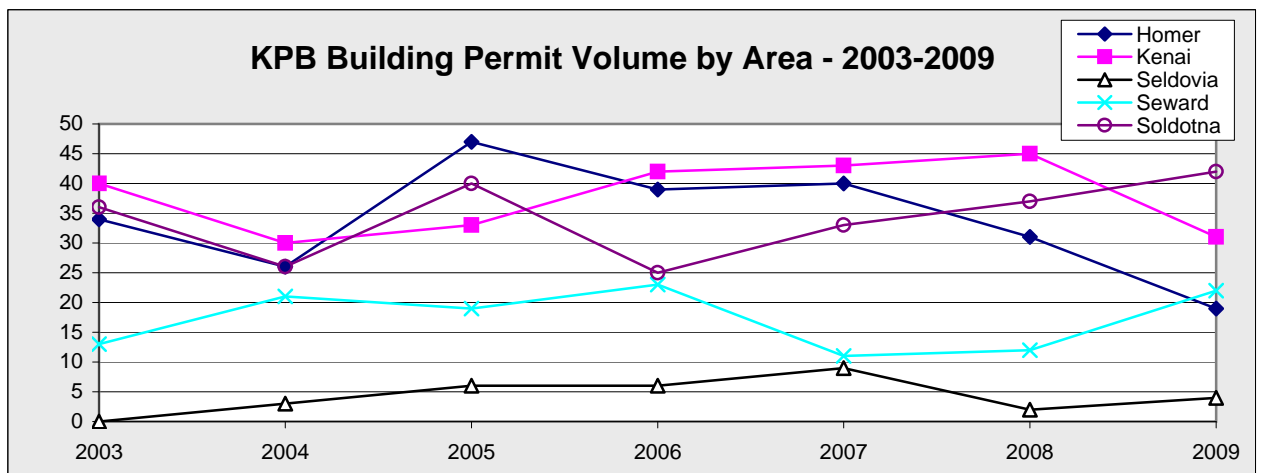

Chart 1.29

KPB Construction Permits

KPB 2nd Quarter Permit Values by Type - 2003-2009 - in \$

	2003	2004	2005	2006	2007	2008	2009	Annual Change
Res. New	7,868,834	6,374,487	7,560,499	10,219,599	15,032,392	13,893,346	7,997,945	-42.4%
Res. Alter/Add	984,340	483,839	812,470	830,630	1,456,488	777,639	605,535	-22.1%
Cml.l New	8,965,210	11,147,815	11,897,148	8,135,648	4,437,143	25,579,000	11,010,639	-57.0%
Cml. Alter/Add	745,400	2,673,643	1,589,958	1,941,323	2,566,570	2,446,000	2,550,826	4.3%
Total	18,563,784	20,679,784	21,860,075	21,127,200	23,492,593	42,695,985	22,164,945	-48.1%
Annual Change		11.4%	5.7%	-3.4%	11.2%	81.7%	-48.1%	

Table 1.41

KPB 2nd Quarter Permit Volume by Type - 2003-2009

	2003	2004	2005	2006	2007	2008	2009	Annual Change
Res. New	47	34	49	57	59	56	42	-25.0%
Res. Alter/Add	33	30	46	40	34	37	40	8.1%
Cml. New	17	11	27	22	17	8	8	0.0%
Cml. Alter/Add	26	31	23	16	26	26	28	7.7%
Total	123	106	145	135	136	127	118	-7.1%
Annual Change		-13.8%	36.8%	-6.9%	0.7%	-6.6%	-7.1%	

Table 1.42

**KPB Second Quarter Building Permit Values by Type
2003-2009**

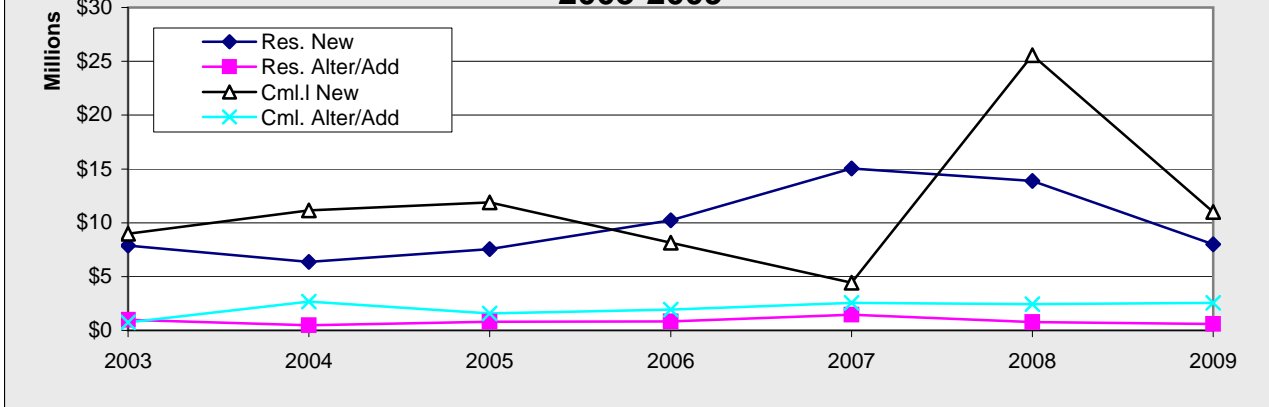

Chart 1.30

**KPB Second Quarter Building Permit Volume by Type
2003-2009**

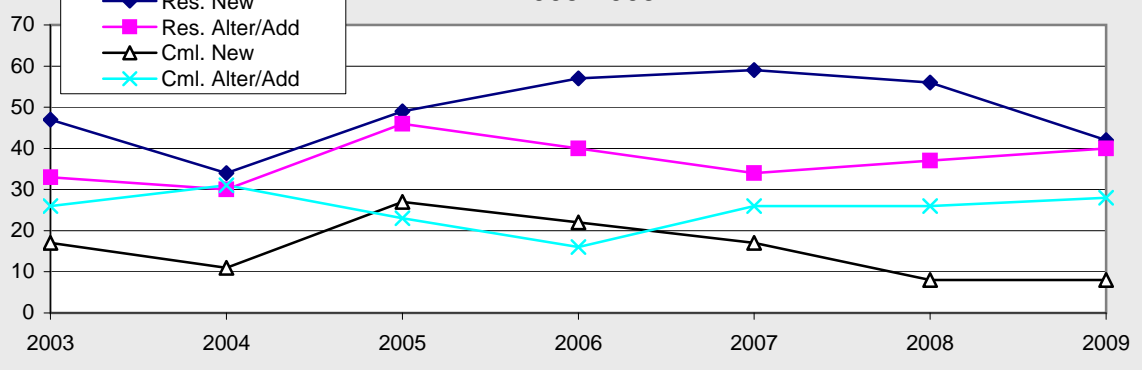

Chart 1.31

KPB Construction Permits

KPB YTD June 30 Permit Values by Area - 2003-2009 - in \$

	2003	2004	2005	2006	2007	2008	2009	Annual Change
Homer	9,263,840	11,147,731	14,351,900	10,738,100	7,347,002	17,874,000	3,501,500	-80.4%
Kenai	4,285,950	2,209,400	2,982,800	4,920,600	6,937,600	20,044,200	3,706,270	-81.5%
Seldovia	31,000	176,200	481,000	117,000	282,000	19,500	307,500	1477%
Seward	5,577,365	15,185,500	1,930,840	2,806,889	2,691,525	2,253,879	17,585,919	680.3%
Soldotna	4,660,942	8,812,896	8,253,790	9,347,769	8,704,976	7,518,374	5,747,876	-23.5%
Total	23,819,097	37,531,727	28,000,330	27,930,358	25,963,103	47,709,953	30,849,065	-35.3%
Annual Change		57.6%	-25.4%	-0.2%	-7.0%	83.8%	-35.3%	

Table 1.43

KPB YTD June 30 Permit Volume by Area - 2003-2009

	2003	2004	2005	2006	2007	2008	2009	Annual Change
Homer	52	42	65	53	43	38	23	-39.5%
Kenai	48	34	43	56	54	57	38	-33.3%
Seldovia	3	4	7	7	10	3	4	33.3%
Seward	24	28	31	30	18	17	29	70.6%
Soldotna	42	35	56	30	42	58	53	-8.6%
Total	169	143	202	176	167	173	147	-15.0%
Annual Change		-15.4%	41.3%	-12.9%	-5.1%	3.6%	-15.0%	

Table 1.44

KPB YTD Building Permit Values by Area - 2003-2009

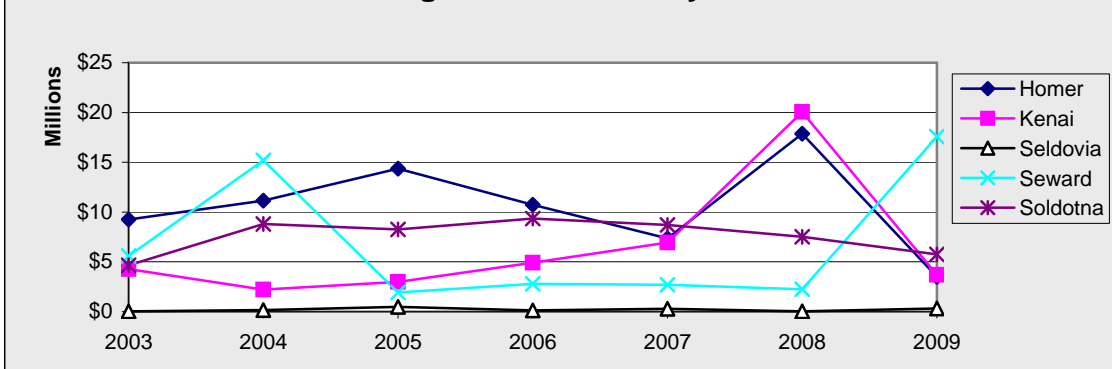

Chart 1.32

KPB YTD Building Permit Volume by Area - 2003-2009

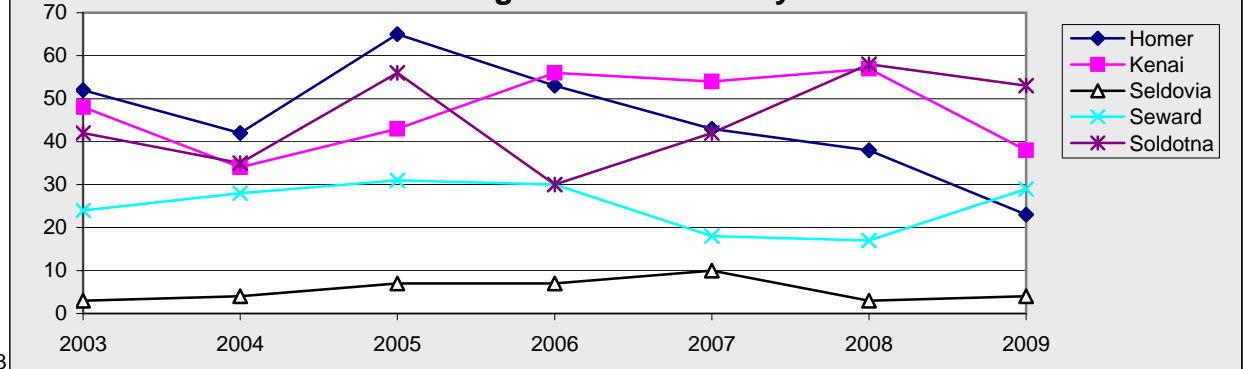

Chart 1.33

KPB Construction Permits

KPB YTD June 30 Permit Values by Type - 2003-2009 - in \$								
	2003	2004	2005	2006	2007	2008	2009	Annual Change
Res.New	8,966,634	9,831,284	10,898,855	12,476,630	16,150,114	15,535,623	8,627,945	-44.5%
Res. Alter/Add	1,378,207	745,359	1,228,400	875,630	1,765,037	982,350	867,535	-11.7%
Cml. New	9,037,210	24,027,841	12,206,148	9,074,058	4,645,656	27,043,737	12,038,639	-55.5%
Cml. Alter/Add	4,437,046	2,927,243	3,666,927	5,504,040	3,402,296	4,148,243	9,313,946	124.5%
Total	23,819,097	37,531,727	28,000,330	27,930,358	25,963,103	47,709,953	30,848,065	-35.3%
Annual Change		57.6%	-25.4%	-0.2%	-7.0%	83.8%	-35.3%	

Table 1.45

KPB YTD June 30 Permit Volume by Type - 2003-2009								
	2003	2004	2005	2006	2007	2008	2009	Annual Change
Residential New	54	51	67	70	67	64	45	-29.7%
Residential Alter/Ad	50	35	60	45	42	47	51	8.5%
Commercial New	18	18	33	27	19	13	12	-7.7%
Commercial Alter/A	47	39	42	34	39	49	39	-20.4%
Total	169	143	202	176	167	173	147	-15.0%
Annual Change		-15.4%	41.3%	-12.9%	-5.1%	3.6%	-15.0%	

Table 1.46

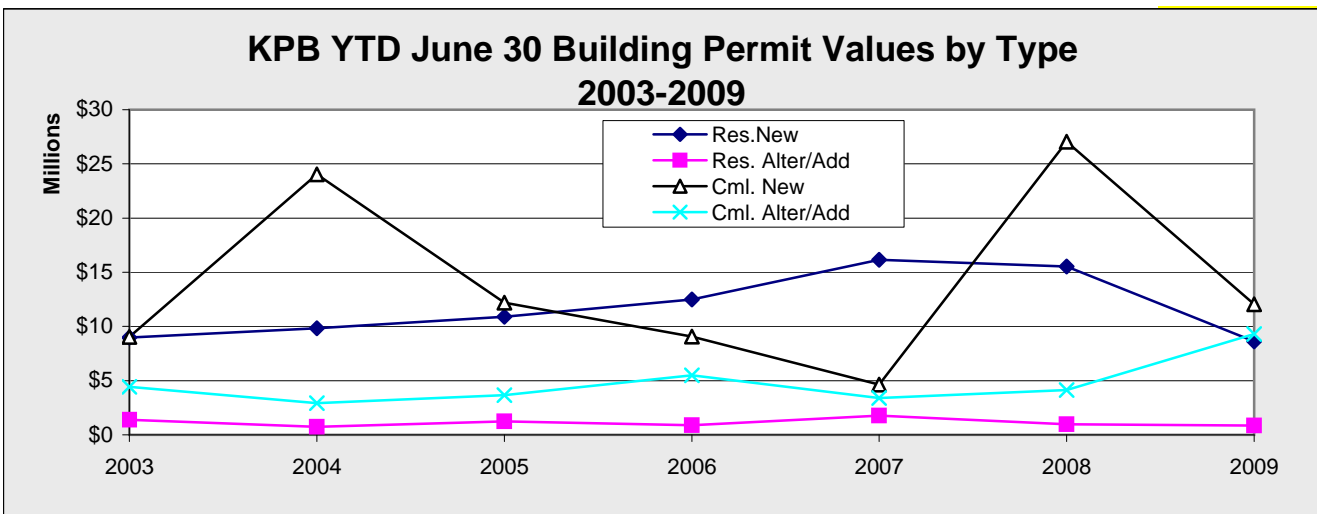

Chart 1.34

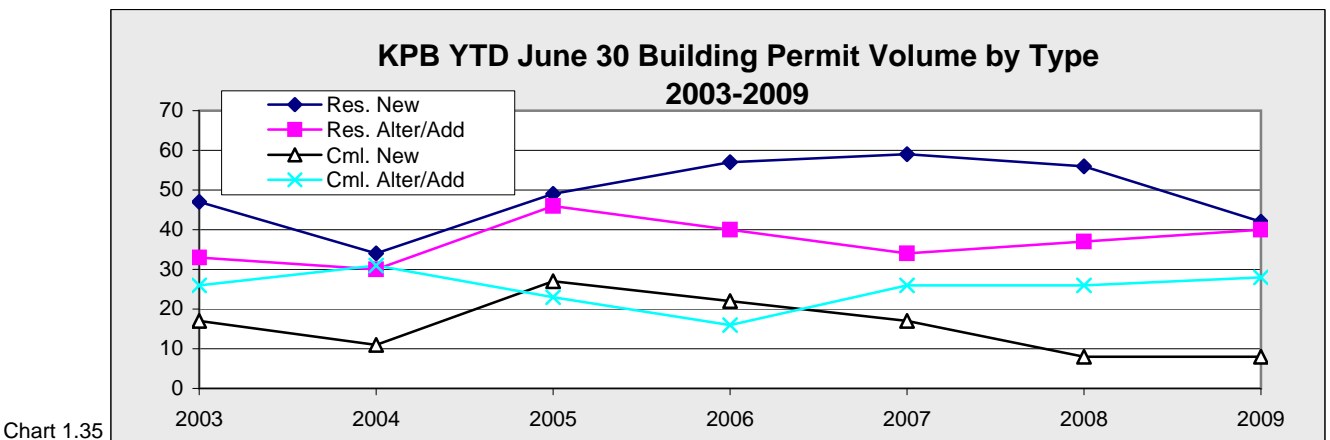

Chart 1.35

KPB Construction Permits

KPB Annual Permit Values by Area - 2003 - 2008 - in \$							
	2003	2004	2005	2006	2007	2008	Annual Change
Homer	15,326,815	24,070,631	21,611,400	20,287,857	14,056,202	\$23,168,200	64.8%
Kenai	10,441,800	4,786,550	8,237,900	11,076,154	22,398,000	\$46,486,375	107.5%
Seldovia	1,902,500	176,200	512,000	135,000	343,800	\$382,500	11.3%
Seward	7,982,765	17,711,150	2,863,143	25,537,249	21,095,925	\$2,832,379	-86.6%
Soldotna	7,952,297	37,296,926	11,509,360	23,194,400	13,762,923	\$19,493,181	41.6%
Total	43,606,177	84,041,457	44,733,803	80,230,660	71,656,850	\$92,362,635	28.9%
Annual Change		92.7%	-46.8%	79.4%	-10.7%	28.9%	

Table 1.47

KPB Annual Permit Volume by Area - 2003 - 2008							
	2003	2004	2005	2006	2007	2008	Annual Change
Homer	86	108	103	83	87	62	-28.7%
Kenai	114	79	90	113	112	114	1.8%
Seldovia	12	4	10	8	18	7	-61.1%
Seward	50	54	54	55	37	30	-18.9%
Soldotna	74	67	81	64	80	91	13.8%
Total	336	312	338	323	334	304	-9.0%
Annual Change		-7.1%	8.3%	-4.4%	3.4%	-9.0%	

Table 1.48

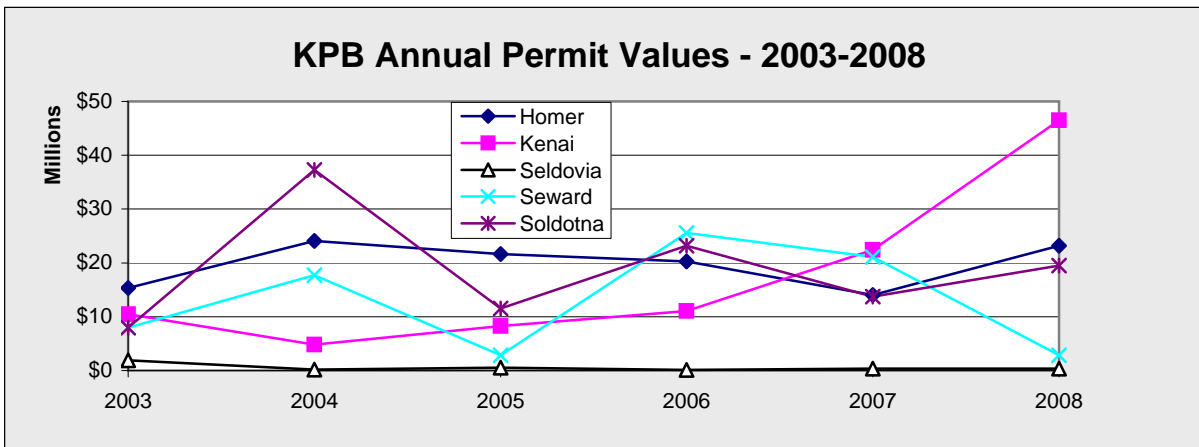

Chart 1.36

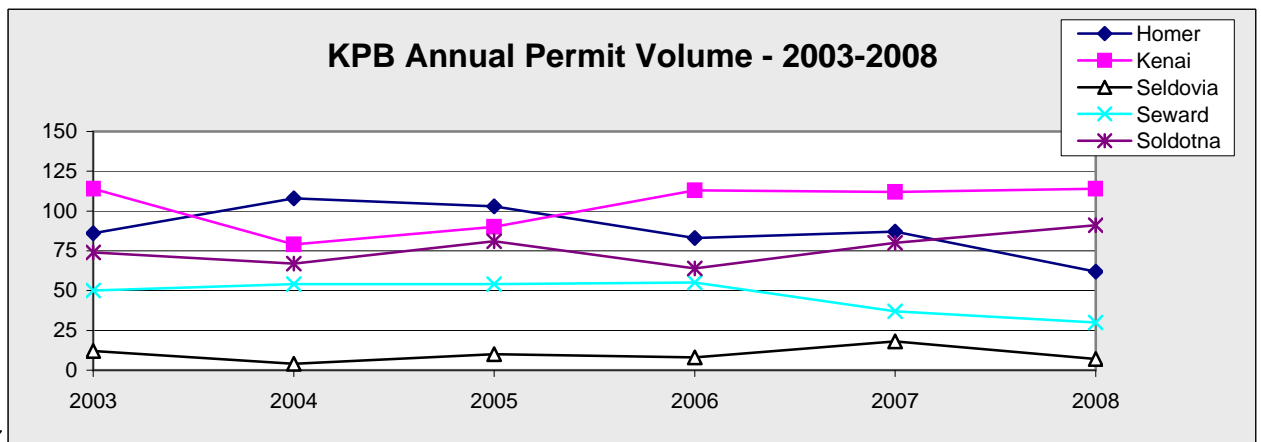

Chart 1.37

KPB Construction Permits

KPB Annual Permit Values by Type - 2003-2008 - in \$

	2003	2004	2005	2006	2007	2008	Annual Change
Res. New	15,729,888	15,935,344	17,749,648	26,277,740	22,612,367	21,563,338	-4.6%
Res. Alter/Add	2,280,779	2,880,284	2,235,128	2,070,180	4,106,440	2,728,588	-33.6%
Cml. New	15,820,201	56,079,343	19,217,548	44,002,152	33,951,168	61,078,166	79.9%
Cml. Alter/Add	9,775,309	9,146,486	5,531,479	7,880,588	10,986,875	6,992,543	-36.4%
Total	43,606,177	84,041,457	44,733,803	80,230,660	71,656,850	92,362,635	28.9%
Annual Change		92.7%	-46.8%	79.4%	-10.7%	28.9%	

Table 1.49

KPB Annual Permit Volume by Type - 2003-2008

	2003	2004	2005	2006	2007	2008	Annual Change
Res. New	104	94	111	126	110	93	-15.5%
Res. Alter/Add	94	96	106	86	119	105	-11.8%
Cml. New	42	42	46	43	37	27	-27.0%
Cml. Alter/Add	96	80	75	68	68	79	16.2%
Total	336	312	338	323	334	304	-9.0%
Annual Change		-7.1%	8.3%	-4.4%	3.4%	-9.0%	

Table 1.50

KPB Annual Permit Values - 2003-2008

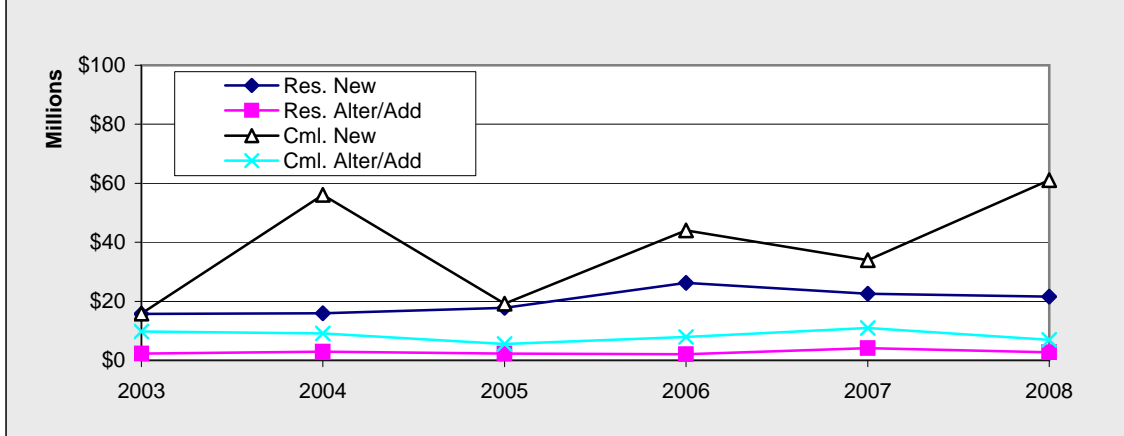

Chart 1.38

KPB Annual Permit Volume - 2003-2008

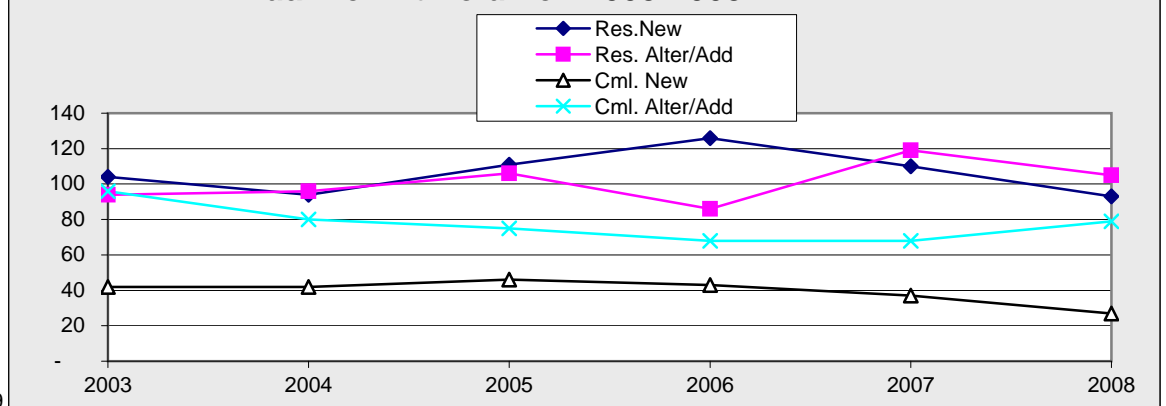

Chart 1.39

KPB Construction Permits

KPB Annual Permit Value by Area by Quarter - 2003-2009					
	1st Quarter	2nd Quarter	3rd Quarter	4th Quarter	TOTAL
2003					
Homer	1,334,340	7,929,500	3,020,075	3,042,900	15,326,815
Kenai	1,557,600	2,728,350	3,700,350	2,455,500	10,441,800
Seldovia	31,000	0	1,835,000	36,500	1,902,500
Seward	1,905,355	3,672,010	1,832,900	572,500	7,982,765
Soldotna	427,018	4,233,924	2,418,310	873,045	7,952,297
TOTAL	5,255,313	18,563,784	12,806,635	6,980,445	43,606,177
2004					
Homer	3,714,020	7,433,711	9,531,900	3,391,000	24,070,631
Kenai	312,000	1,897,400	1,991,750	585,400	4,786,550
Seldovia	20,000	156,200	0	0	176,200
Seward	7,741,600	7,443,900	2,266,300	259,350	17,711,150
Soldotna	5,064,323	3,748,573	23,780,115	4,703,915	37,296,926
TOTAL	16,851,943	20,679,784	37,570,065	8,939,665	84,041,457
2005					
Homer	3,105,900	11,246,000	4,282,500	2,977,000	21,611,400
Kenai	425,500	2,557,300	4,035,100	1,220,000	8,237,900
Seldovia	15,000	466,000	30,500	500	512,000
Seward	1,172,300	758,540	825,446	106,857	2,863,143
Soldotna	1,421,555	6,832,235	3,085,730	169,840	11,509,360
TOTAL	6,140,255	21,860,075	12,259,276	4,474,197	44,733,803
2006					
Homer	3,271,000	7,467,100	6,994,757	2,555,000	20,287,857
Kenai	763,500	4,157,100	4,367,654	1,787,900	11,076,154
Seldovia	30,000	87,000	0	18,000	135,000
Seward	622,217	2,184,672	20,786,060	1,944,300	25,537,249
Soldotna	2,116,441	7,231,328	13,213,749	632,882	23,194,400
TOTAL	6,803,158	21,127,200	45,362,220	6,938,082	80,230,660
2007					
Homer	55,001	7,292,001	5,087,200	1,622,000	14,056,202
Kenai	769,500	6,168,100	15,020,700	439,700	22,398,000
Seldovia	15,000	267,000	60,800	1,000	343,800
Seward	803,238	1,888,287	264,900	18,139,500	21,095,925
Soldotna	827,771	7,877,205	2,765,902	2,292,045	13,762,923
TOTAL	2,470,510	23,492,593	23,199,502	22,494,245	71,656,850
2008					
Homer	1,223,000	16,651,000	2,410,200	2,884,000	23,168,200
Kenai	1,063,300	18,980,900	24,976,300	1,465,875	46,486,375
Seldovia	12,000	7,500	353,000	10,000	382,500
Seward	409,415	1,844,464	216,500	362,000	2,832,379
Soldotna	2,306,253	5,212,121	11,710,661	264,146	19,493,181
TOTAL	5,013,968	42,695,985	39,666,661	4,986,021	92,362,635
2009					YTD
Homer	1,110,000	2,390,500			3,500,500
Kenai	493,000	3,213,270			3,706,270
Seldovia	-	307,500			307,500
Seward	6,627,120	10,958,799			17,585,919
Soldotna	453,000	5,294,876			5,747,876
TOTAL	8,683,120	22,164,945			30,848,065

Table 1.51

KPB Construction Permits

KPB Annual Permit Values by Type by Quarter - 2003-2009 - in \$					
	1st Quarter	2nd Quarter	3rd Quarter	4th Quarter	TOTAL
2003					
Residential New	1,097,800	7,868,834	4,209,163	2,554,091	15,729,888
Residential Alter/Add	393,867	984,340	611,572	291,000	2,280,779
Commercial New	72,000	8,965,210	4,636,000	2,146,991	15,820,201
Commercial Alter/Add	3,691,646	745,400	3,349,900	1,988,363	9,775,309
TOTAL	5,255,313	18,563,784	12,806,635	6,980,445	43,606,177
2004					
Residential New	3,456,797	6,374,487	4,950,200	1,153,860	15,935,344
Residential Alter/Add	261,520	483,839	1,605,471	529,454	2,880,284
Commercial New	12,880,026	11,147,815	28,989,901	3,061,601	56,079,343
Commercial Alter/Add	253,600	2,673,643	2,024,493	4,194,750	9,146,486
TOTAL	16,851,943	20,679,784	37,570,065	8,939,665	84,041,457
2005					
Residential New	3,338,356	7,560,499	4,843,170	2,007,623	17,749,648
Residential Alter/Add	415,930	812,470	805,771	200,957	2,235,128
Commercial New	309,000	11,897,148	4,848,400	2,163,000	19,217,548
Commercial Alter/Add	2,076,969	1,589,958	1,761,935	102,617	5,531,479
TOTAL	6,140,255	21,860,075	12,259,276	4,474,197	44,733,803
2006					
Residential New	2,257,031	10,219,599	11,744,277	2,056,833	26,277,740
Residential Alter/Add	45,000	830,630	887,191	307,359	2,070,180
Commercial New	938,410	8,135,648	30,656,794	4,271,300	44,002,152
Commercial Alter/Add	3,562,717	1,941,323	2,073,958	302,590	7,880,588
TOTAL	6,803,158	21,127,200	45,362,220	6,938,082	80,230,660
2007					
Residential New	1,117,722	15,032,392	5,529,253	933,000	22,612,367
Residential Alter/Add	308,549	1,456,488	1,465,038	876,365	4,106,440
Commercial New	208,513	4,437,143	9,350,400	19,955,112	33,951,168
Commercial Alter/Add	835,726	2,566,570	6,854,811	729,768	10,986,875
TOTAL	2,470,510	23,492,593	23,199,502	22,494,245	71,656,850
2008					
Residential New	1,642,277	13,893,346	4,398,840	1,628,875	21,563,338
Residential Alter/Add	204,711	777,639	894,238	852,000	2,728,588
Commercial New	1,464,737	25,579,000	33,113,283	921,146	61,078,166
Commercial Alter/Add	1,702,243	2,446,000	1,260,300	1,584,000	6,992,543
TOTAL	5,013,968	42,695,985	39,666,661	4,986,021	92,362,635
2009					
					YTD
Residential New	630,000	7,997,945			8,627,945
Residential Alter/Add	262,000	605,535			867,535
Commercial New	1,028,000	11,010,639			12,038,639
Commercial Alter/Add	6,763,120	2,550,826			9,313,946
TOTAL	8,683,120	22,164,945	0	0	30,848,065

Table 1.52

KPB Construction Permits

KPB Annual Permit Volume by Area by Quarter - 2003-2009					
	1st Quarter	2nd Quarter	3rd Quarter	4th Quarter	TOTAL
2003					
Homer	18	34	21	13	86
Kenai	8	40	45	21	114
Seldovia	3	0	5	4	12
Seward	11	13	15	11	50
Soldotna	6	36	19	13	74
TOTAL	46	123	105	62	336
2004					
Homer	16	26	42	24	108
Kenai	4	30	31	14	79
Seldovia	1	3	0	0	4
Seward	7	21	19	7	54
Soldotna	9	26	24	8	67
TOTAL	37	106	116	53	312
2005					
Homer	18	47	27	11	103
Kenai	10	33	33	14	90
Seldovia	1	6	2	1	10
Seward	12	19	16	7	54
Soldotna	16	40	20	5	81
TOTAL	57	145	98	38	338
2006					
Homer	14	39	25	5	83
Kenai	14	42	43	14	113
Seldovia	1	6	0	1	8
Seward	7	23	19	6	55
Soldotna	5	25	27	7	64
TOTAL	41	135	114	33	323
2007					
Homer	3	40	28	16	87
Kenai	11	43	44	14	112
Seldovia	1	9	7	1	18
Seward	7	11	10	9	37
Soldotna	9	33	22	16	80
TOTAL	31	136	111	56	334
2008					
Homer	7	31	13	11	62
Kenai	12	45	42	15	114
Seldovia	1	2	3	1	7
Seward	5	12	4	9	30
Soldotna	21	37	28	5	91
TOTAL	46	127	90	41	304
2009					
					YTD
Homer	4	19			23
Kenai	7	31			38
Seldovia	0	4			4
Seward	7	22			29
Soldotna	11	42			53
TOTAL	29	118	0	0	147

Table 1.53

KPB Construction Permits

KPB Annual Permit Volume by Type by Quarter - 2003-2009					
	1st Quarter	2nd Quarter	3rd Quarter	4th Quarter	TOTAL
2003					
Residential New	7	47	28	22	104
Residential Alter/Add	17	33	34	10	94
Commercial New	1	17	17	7	42
Commercial Alter/Add	21	26	26	23	96
TOTAL	46	123	105	62	336
2004					
Residential New	17	34	32	11	94
Residential Alter/Add	5	30	44	17	96
Commercial New	7	11	15	9	42
Commercial Alter/Add	8	31	25	16	80
TOTAL	37	106	116	53	312
2005					
Residential New	18	49	31	13	111
Residential Alter/Add	14	46	36	10	106
Commercial New	6	27	9	4	46
Commercial Alter/Add	19	23	22	11	75
TOTAL	57	145	98	38	338
2006					
Residential New	13	57	48	8	126
Residential Alter/Add	5	40	32	9	86
Commercial New	5	22	9	7	43
Commercial Alter/Add	18	16	25	9	68
TOTAL	41	135	114	33	323
2007					
Residential New	8	59	36	7	110
Residential Alter/Add	8	34	51	26	119
Commercial New	2	17	10	8	37
Commercial Alter/Add	13	26	14	15	68
TOTAL	31	136	111	56	334
2008					
Residential New	8	56	19	10	93
Residential Alter/Add	10	37	44	14	105
Commercial New	5	8	10	4	27
Commercial Alter/Add	23	26	17	13	79
TOTAL	46	127	90	41	304
2009					
					YTD
Residential New	3	42			45
Residential Alter/Add	11	40			51
Commercial New	4	8			12
Commercial Alter/Add	11	8			19
TOTAL	29	98	0	0	127

Table 1.54

KPB Unemployment Statistics

Unemployment data are acquired from the Alaska Department of Labor and Workforce Development (AK DOLWD) and are developed through a survey, with survey data entered into a standardized model that is used throughout the United States. The estimated total labor force include all residents willing and able to work, whether or not they are employed. Employment includes all members of the labor force who are gainfully employed. Unemployment is calculated by subtracting the estimate of gainfully employed persons from the total labor force. Lastly, the unemployment rate is calculated by dividing the number of unemployed persons by the total labor force.

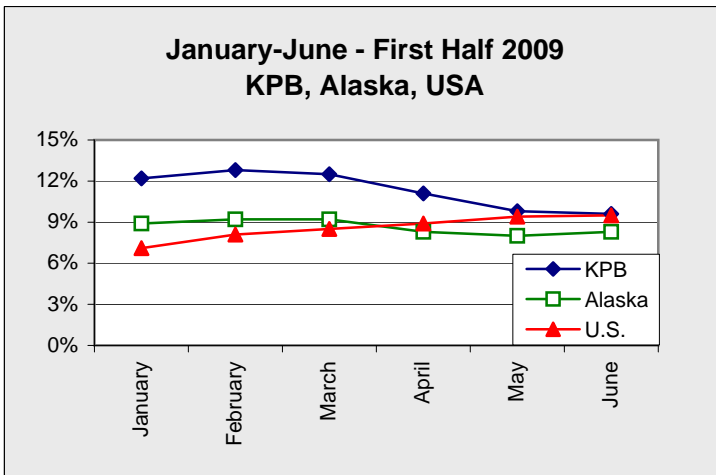

The chart to the left provides a clear picture of the standard relationship between unemployment rates of our country, state and the KPB. Typically, each area reaches its annual high in unemployment during the first quarter. Also, generally, the United States rate is the lowest, followed by Alaska, with the KPB having the highest rate in this survey driven data set.

Chart 1.40

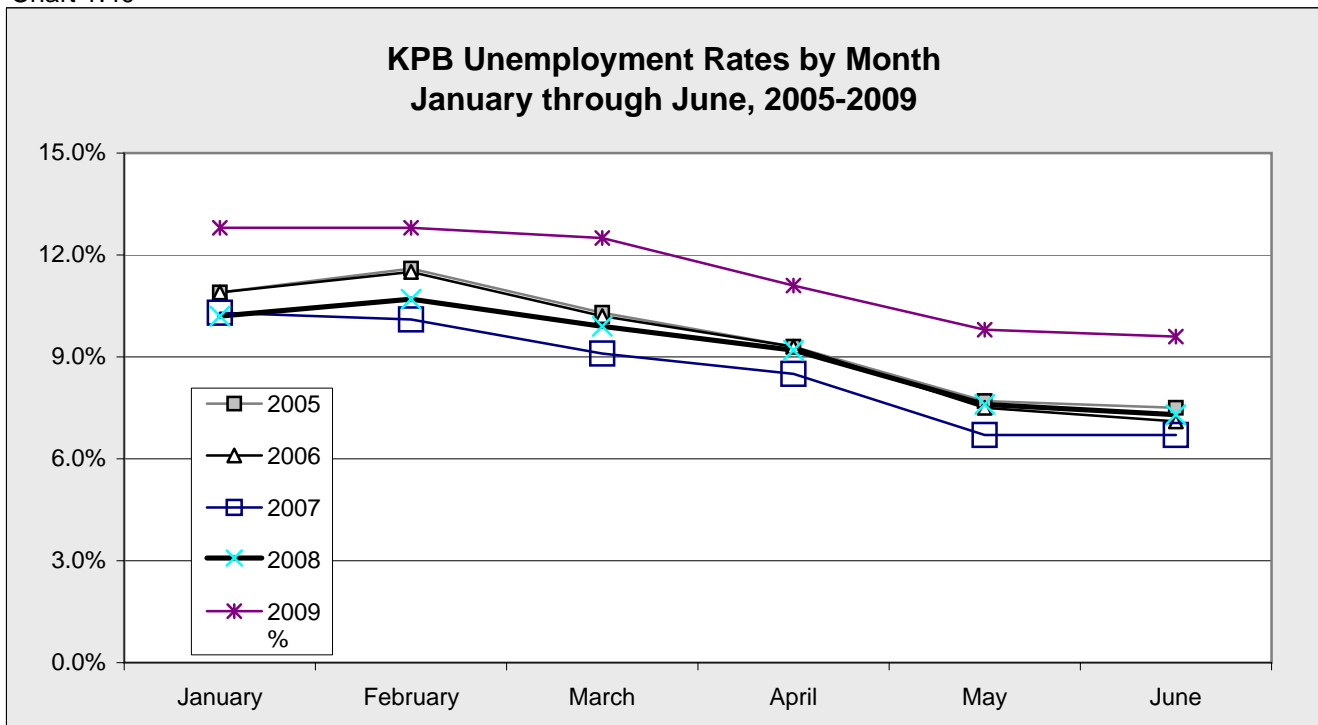

Chart 1.41

KPB Unemployment Statistics

KPB Labor Force by Month - 2000-2009

	Jan	Feb	Mar	Apr	May	Jun	Jul	Aug	Sep	Oct	Nov	Dec	Avg
2000	23,011	23,329	23,290	23,365	24,542	26,598	26,448	26,243	25,160	24,101	24,071	24,174	24,528
2001	23,056	23,003	23,055	23,139	24,195	26,114	26,836	25,619	24,496	23,717	23,656	23,801	24,224
2002	23,659	23,374	23,569	24,173	24,925	25,919	26,796	26,125	24,942	24,317	24,294	24,409	24,709
2003	24,298	24,108	24,243	24,379	25,394	26,781	27,170	26,352	24,571	24,028	23,988	23,875	24,932
2004	23,874	24,000	24,130	24,130	25,302	27,119	27,599	26,342	24,958	24,334	24,116	23,981	24,990
2005	23,977	23,941	24,094	24,081	25,254	26,855	27,547	26,324	24,873	24,309	23,952	23,897	24,925
2006	24,261	24,422	24,254	24,457	25,770	27,205	27,625	27,383	25,518	24,741	24,605	24,773	25,418
2007	24,577	24,659	24,675	24,672	25,835	27,390	27,497	27,399	26,075	24,564	24,678	24,760	25,565
2008	24,640	24,888	25,357	25,374	26,786	28,189	28,334	28,080	26,441	25,626	25,470	25,689	26,240
2009	25,319	25,363	25,525	25,594	27,305	28,515							26,270

Table 1.55

KPB Unemployment by Month - 2000-2009

	Jan	Feb	Mar	Apr	May	Jun	Jul	Aug	Sep	Oct	Nov	Dec	Avg
2000	2,530	2,575	2,445	2,138	1,943	1,843	1,546	1,556	1,496	1,671	1,871	2,019	1,969
2001	2,327	2,379	2,276	2,045	1,767	1,813	1,543	1,560	1,560	1,754	1,965	2,181	1,931
2002	2,503	2,518	2,542	2,335	2,117	2,207	1,981	2,007	2,092	2,247	2,466	2,690	2,309
2003	2,935	3,048	2,795	2,564	2,345	2,542	2,169	2,122	2,126	2,301	2,508	2,636	2,508
2004	2,956	2,969	2,897	2,508	2,272	2,419	2,033	1,956	1,971	2,129	2,309	2,429	2,404
2005	2,625	2,774	2,493	2,231	1,942	2,015	1,773	1,737	1,809	1,921	2,092	2,249	2,138
2006	2,638	2,812	2,475	2,273	1,926	1,929	1,794	1,658	1,721	1,740	1,986	2,256	2,101
2007	2,537	2,487	2,249	2,085	1,743	1,848	1,619	1,581	1,690	1,650	1,988	2,203	1,973
2008	2,514	2,660	2,513	2,333	2,038	2,063	1,865	1,810	1,917	2,093	2,297	2,589	2,224
2009	3,084	3,240	3,189	2,852	2,664	2,742							2,962

Table 1.56

KPB Unemployment Rate by Month - 2000-2009

	Jan	Feb	Mar	Apr	May	Jun	Jul	Aug	Sep	Oct	Nov	Dec	Avg
2000	11.0%	11.0%	10.5%	9.2%	7.9%	6.9%	5.8%	5.9%	5.9%	6.9%	7.8%	8.4%	8.1%
2001	10.1%	10.3%	9.9%	8.8%	7.3%	6.9%	5.7%	6.1%	6.4%	7.4%	8.3%	9.2%	8.0%
2002	10.6%	10.8%	10.8%	9.7%	8.5%	8.5%	7.4%	7.7%	8.4%	9.2%	10.2%	11.0%	9.4%
2003	12.1%	12.6%	11.5%	10.5%	9.2%	9.5%	8.0%	8.1%	8.7%	9.6%	10.5%	11.0%	10.1%
2004	12.4%	12.4%	12.0%	10.4%	9.0%	8.9%	7.4%	7.4%	7.9%	8.7%	9.6%	10.1%	9.7%
2005	10.9%	11.6%	10.3%	9.3%	7.7%	7.5%	6.4%	6.6%	7.3%	7.9%	8.7%	9.4%	8.6%
2006	10.9%	11.5%	10.2%	9.3%	7.5%	7.1%	6.5%	6.1%	6.7%	7.0%	8.1%	9.1%	8.3%
2007	10.3%	10.1%	9.1%	8.5%	6.7%	6.7%	5.9%	5.8%	6.5%	6.7%	8.1%	8.9%	7.8%
2008	10.2%	10.7%	9.9%	9.2%	7.6%	7.3%	6.6%	6.4%	7.3%	8.2%	9.0%	10.1%	8.5%
2009	12.2%	12.8%	12.5%	11.1%	9.8%	9.6%							11.3%

Table 1.57

KPB Employment by Month - 2000-2009

	Jan	Feb	Mar	Apr	May	Jun	Jul	Aug	Sep	Oct	Nov	Dec	Avg
2000	20,481	20,754	20,845	21,227	22,599	24,755	24,902	24,687	23,664	22,430	22,200	22,155	22,558
2001	20,729	20,624	20,779	21,094	22,428	24,301	25,293	24,059	22,936	21,963	21,691	21,620	22,293
2002	21,156	20,856	21,027	21,838	22,808	23,712	24,815	24,118	22,850	22,070	21,828	21,719	22,400
2003	21,363	21,060	21,448	21,815	23,049	24,239	25,001	24,230	22,445	21,727	21,480	21,239	22,425
2004	20,918	21,031	21,233	21,622	23,030	24,700	25,566	24,386	22,987	22,205	21,807	21,552	22,586
2005	21,352	21,167	21,601	21,850	23,312	24,840	25,774	24,587	23,064	22,388	21,860	21,648	22,787
2006	21,623	21,610	21,779	22,184	23,844	25,276	25,831	25,725	23,797	23,001	22,619	22,517	23,317
2007	22,040	22,172	22,426	22,587	24,092	25,542	25,878	25,818	24,385	22,914	22,690	22,557	23,592
2008	22,126	22,228	22,844	23,041	24,748	26,126	26,479	26,270	24,524	23,533	23,173	23,100	24,016
2009	22,235	22,123	22,336	22,742	24,641	25,776							23,309

Table 1.58

KPB Demographics

Census 2000

KPB population counts are conducted by the United States Census Bureau every ten years. Check out their website (<http://www.census.gov/>), which has two excellent data options - QuickFacts and AmericanFactFinder.

Census data is collected for two general types of area: incorporated cities and Census Designated Places (CDP). KPB incorporated cities include Homer, Kachemak City, Kenai, Seldovia, Seward and Soldotna. A CDP is delineated by geographic features such as rivers, roads, or ridges. Defining characteristics include:

- * A sense of community;
- * A population of 25 or more; and
- * It must have been recognized as possibly fitting the criteria four years prior to the census, as planning began.

The Census Bureau considers an incorporated city with a population greater than 2,500 to be urban, of which there are four in the KPB: Homer, Kenai, Seward and Soldotna. Kenai is ranked 6th largest city in Alaska, Homer ranks 14th, and Soldotna is the 15th largest as of Census 2000 .

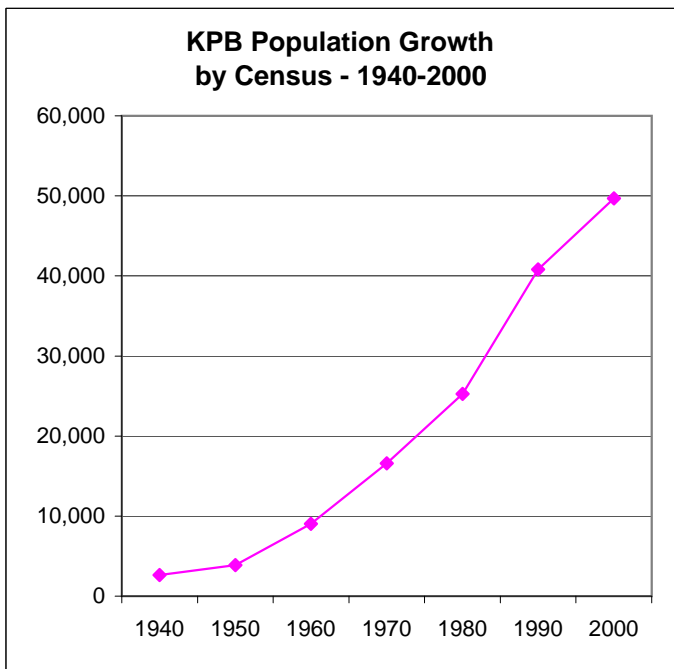

Chart 1.42

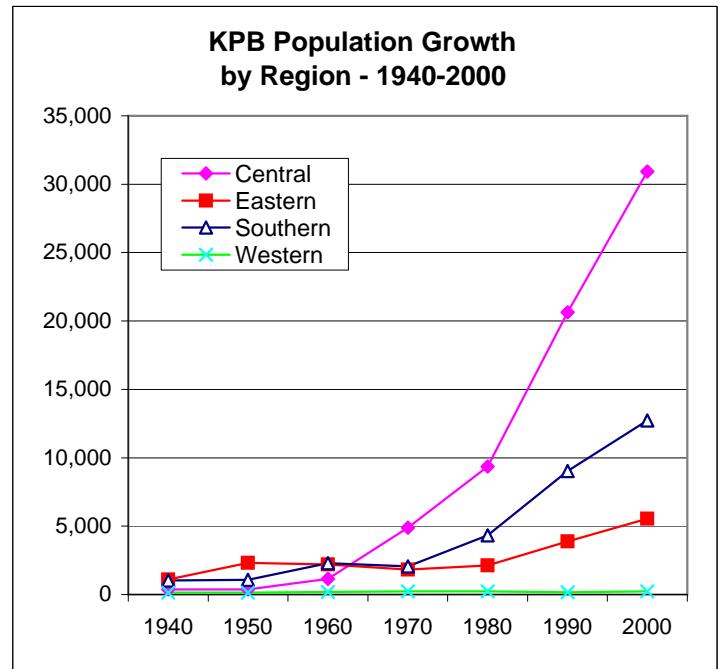

Chart 1.43

Population Estimates

The AK DOLWD prepares annual population estimates for Alaska. Estimates include Armed Forces members serving in Alaska but exclude seasonal populations. Primary indicators for population change include Alaska Permanent Fund Dividend applications, vital statistics, and survey information. Although estimates are identified for July 1, data represents annual average resident population rather than a specific date.

These revised, current estimates are consistent with U.S. Census Bureau statewide total population estimates and supersede all previously published estimates.

<http://almis.labor.state.ak.us/?PAGEID=67&SUBID=171>

KPB Demographics

KPB CDP's - Census 2000, Population Estimates - 2001- 2008 (Revised-5/20/09)										
KPB Community	2000 Census	June 1 Estimate (Subject to Annual Revision)								Annual Change
		2001	2002	2003	2004	2005	2006	2007	2008	
Anchor Point	1,845	1,809	1,780	1,809	1,829	1,753	1,803	1,814	1829	0.8%
Bear Creek	1,748	1,836	1,833	1,829	1,904	1,898	1,922	1,945	1984	2.0%
Beluga	32	24	25	27	26	21	21	19	24	26.3%
Clam Gulch	173	168	173	176	163	171	165	175	164	-6.3%
Cohoe	1,168	1,175	1,211	1,208	1,321	1,282	1,260	1,263	1306	3.4%
Cooper Landing	369	389	370	351	345	343	357	353	357	1.1%
Crown Point	75	89	88	82	90	82	81	74	77	4.1%
Diamond Ridge*	1,802	1,835	412	314	769	743	690	733	794	8.3%
Fox River	616	594	576	582	613	627	639	643	654	1.7%
Fritz Creek	1,603	1,663	1,733	1,742	1,731	1,761	1,723	1,757	1809	3.0%
Funny River	636	624	687	707	736	746	729	747	763	2.1%
Halibut Cove	35	29	28	27	26	23	24	20	23	15.0%
Happy Valley	489	505	521	505	528	483	472	495	513	3.6%
Homer*	3,946	4,070	5,535	5,877	5,350	5,394	5,454	5,502	5390	-2.0%
Hope	137	145	152	161	165	141	143	147	148	0.7%
Kachemak	431	426	433	478	470	460	458	467	453	-3.0%
Kalifornsky	5,846	6,017	6,159	6,248	6,638	6,825	6,914	7,129	7312	2.6%
Kasilof	471	452	501	559	473	509	547	596	560	-6.0%
Kenai	6,942	6,889	7,076	7,129	6,839	6,768	6,864	6,971	7134	2.3%
Lowell Point	92	96	108	89	76	96	76	85	88	3.5%
Miller Landing*	74	70	Annexed into Homer							
Moose Pass	206	206	217	219	220	217	204	201	186	-7.5%
Nanwalek	177	184	219	214	204	219	228	217	229	5.5%
Nikiski	4,327	4,363	4,362	4,351	4,289	4,190	4,179	4,345	4406	1.4%
Nikolaevsk	345	345	334	315	309	305	297	297	296	-0.3%
Ninilchik	772	760	762	774	786	786	784	778	853	9.6%
Port Graham	171	178	174	165	153	128	136	134	136	1.5%
Primrose	93	99	92	87	91	84	79	78	77	-1.3%
Ridgeway	1,932	1,962	1,968	2,020	2,058	2,060	1,961	1,987	1980	-0.4%
Salamatof	954	912	915	923	920	911	906	878	895	1.9%
Seldovia	430	435	449	430	423	390	379	445	423	-4.9%
Seldovia City	286	287	288	279	264	240	220	284	257	-9.5%
Seldovia Village	144	148	161	151	159	150	159	161	166	3.1%
Seward	2,830	2,759	2,755	2,744	2,542	2,595	2,627	2,661	2619	-1.6%
Soldotna	3,759	3,793	3,851	4,001	3,776	3,794	3,807	3,982	4061	2.0%
Sterling	4,705	4,756	4,780	4,878	4,919	4,980	5,036	5,123	5134	0.2%
Sunrise	18	16	14	15	19	24	22	20	22	10.0%
Tyonek	193	161	181	192	185	199	199	181	154	-14.9%
Remainder Kenai/Cook Inlet		229	187	195	189	168	153	118	131	11.0%
Remainder Seward census sub area		23	13	23	18	15	11	6	6	
Remainder of KPB	249									
Kenai Peninsula	49,691	50,086	50,674	51,446	51,193	51,191	51,350	52,407	52,990	1.1%

Table 1.59

* - Homer annexation included all of Miller Landing CDP and part of Diamond Ridge CDP. Annexation was effective April 1, 2002.

Note - All Estimates since 2000 have been revised by the State of Alaska Department of Labor and Workforce Development.

Source - <http://www.labor.state.ak.us/research/pop/estimates08t4.3.xls>

KPB Demographics

KPB Census by City/CDP - 1940-2000									
KPB Community	Region	1940	1950	1960	1970	1980	1990	2000	
Anchor Point	S	20	65	171	102	226	866	1,845	
Bear Creek	E	0	0	0	0	0	580	1,748	
Beluga	W	New CDP - Census 2000							32
Clam Gulch	C	0	0	0	47	50	79	173	
Cohoe	C	0	0	122	0	0	508	1,168	
Cooper Landing	E	0	60	88	31	116	243	369	
Crown Point	E	0	0	0	0	0	62	75	
Diamond Ridge	S	New CDP - Census 2000							1,802
Fox River	S	0	0	0	0	0	382	616	
Fritz Creek	S	0	0	0	27	302	1,426	1,603	
Funny River	C	New CDP - Census 2000							636
Halibut Cove	S	0	0	25	44	47	78	35	
Happy Valley	S	0	0	0	0	0	309	489	
Homer	S	325	307	1,247	1,083	2,209	3,660	3,946	
Hope	E	71	63	44	51	103	161	137	
Jakalof Bay	S	New CDP - 1980, Deleted - Census 2000					36	28	Deleted
Kachemak	S	0	0	0	76	403	365	431	
Kalifornsky	C	0	0	0	0	92	285	5,846	
Kasilof	C	62	62	89	71	201	383	471	
Kenai	C	303	321	778	3,533	4,324	6,327	6,942	
Lowell Point	E	New CDP - Census 2000							92
Miller Landing	S	New CDP - Census 2000							74
Moose Pass	E	84	70	136	53	76	81	206	
Nanwalek	S	48	75	78	58	124	158	177	
Nikiski	C		0	0	0	1,109	2,743	4,327	
Nikolaevsk	S	0	0	0	0	0	371	345	
Ninilchik	S	132	97	169	134	341	456	772	
Port Graham	S	93	92	139	107	161	166	171	
Primrose	E	0	0	0	0	0	63	93	
Ridgeway	C	0	0	0	0	0	2,018	1,932	
Salamatof	C	0	0	0	0	334	999	954	
Seldovia City	S	410	437	460	437	479	316	286	
Seward	E	949	2,114	1,891	1,587	1,843	2,699	2,830	
Soldotna	C	0	0	32	1,202	2,320	3,482	3,759	
Sterling	C	0	0	115	30	919	3,802	4,705	
Sunrise	C	New CDP - Census 2000							18
Tyonek	W	136	132	187	232	239	154	193	
Remainder of census area	E		946	3,282	7,681	16,116	7,409	249	
Kenai Peninsula Borough		2,633	4,831	9,053	16,586	25,282	40,802	49,691	

Table 1.60

KPB Demographics

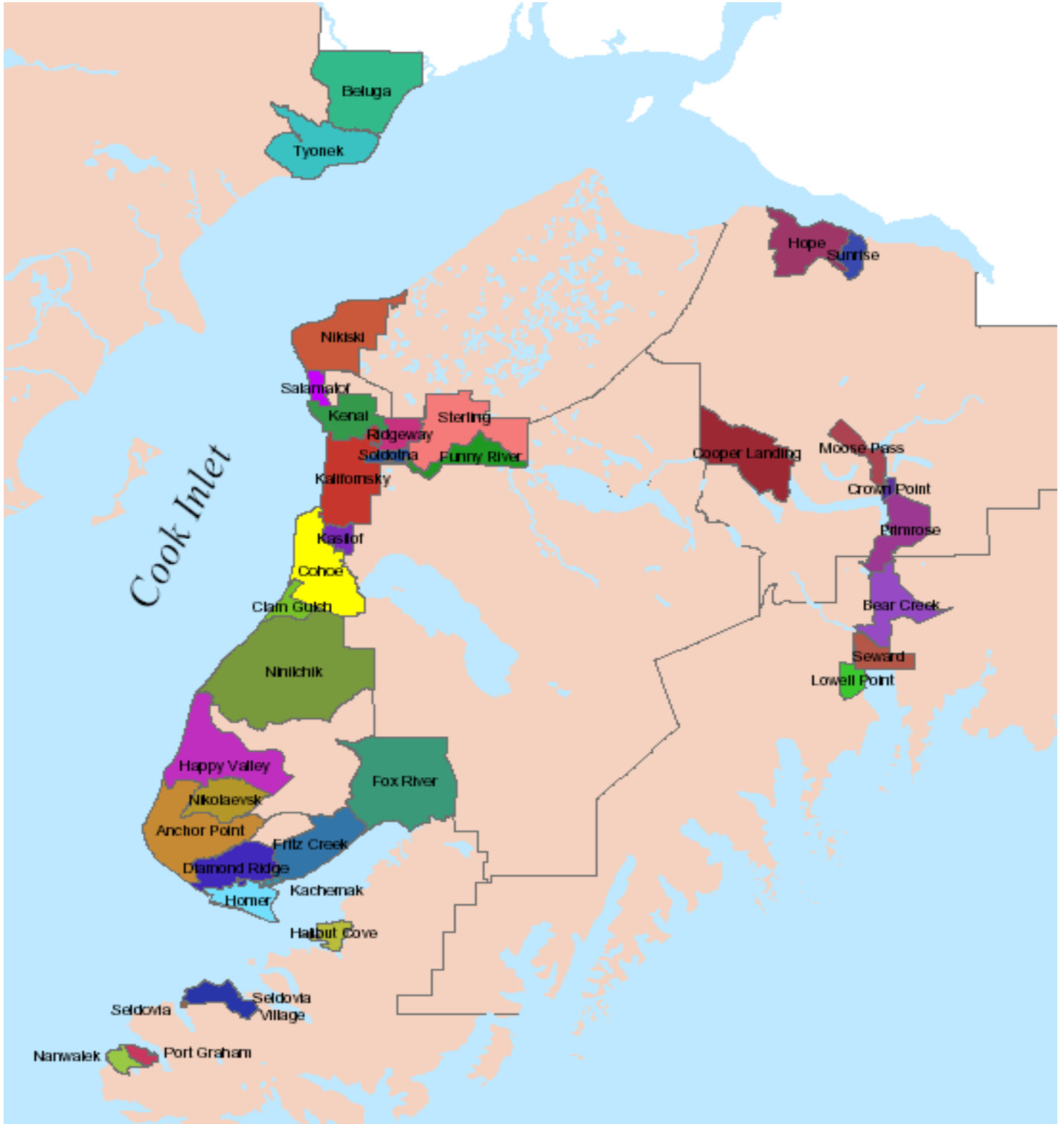

KENAI PENINSULA BOROUGH CENSUS DESIGNATED PLACES

Chart 1.44

KPB Demographics

KPB Population by Age Group - 1990 v 2000 v 2008

	1990	2000	2008	Percent Change-2000, 2008	Percent of Total 2008 Population
Total Population	40,802	49,691	52,990	6.6%	100.00%
Under 5 years	3,862	3,288	3,494	6.3%	6.2%
5 to 9 years	4,059	4,024	3,691	-8.3%	7.6%
10 to 14 years	3,516	4,698	3,826	-18.6%	8.9%
15 to 19 years	2,970	4,140	4,259	2.9%	7.8%
20 to 24 years	2,081	2,132	2,955	38.6%	4.0%
25 to 34 years	7,348	5,648	5,575	-1.3%	10.7%
35 to 44 years	8,234	9,074	6,716	-26.0%	17.1%
45 to 54 years	4,205	8,739	9,443	8.1%	16.5%
55 to 59 years	1,376	2,632	4,440	68.7%	5.0%
60 to 64 years	1,164	1,667	3,177	90.6%	3.1%
65 to 74 years	1,489	2,361	3,485	47.6%	4.5%
75 to 84 years	419	1,077	1,465	36.0%	2.0%
85 years and over	79	211	524	148.3%	0.4%

KPB's median age increased from 31.1 years during 1990 to 36.3 as of Census 2000. Alaska's median age was 32.4 years while the U.S. was 35.3 years, per Census 2000. The KPB 2008 median age is estimated at 39.2 years, down from the 2007 estimate of 39.7 years.

Note - Seldovia challenged the 2007 estimate which resulted in a population increase. Those numbers are not represented here because the breakdown by age has not been updated to the new certified estimate.

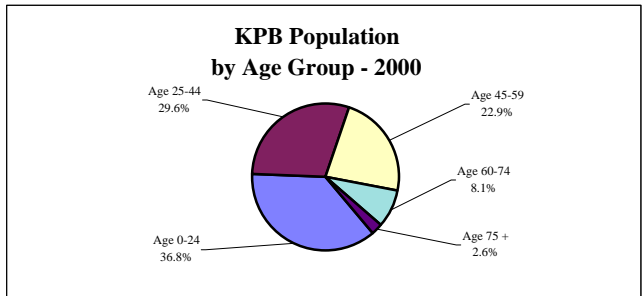

Chart 1.45

KPB Population by Age Group - 1990, 2000, 2008

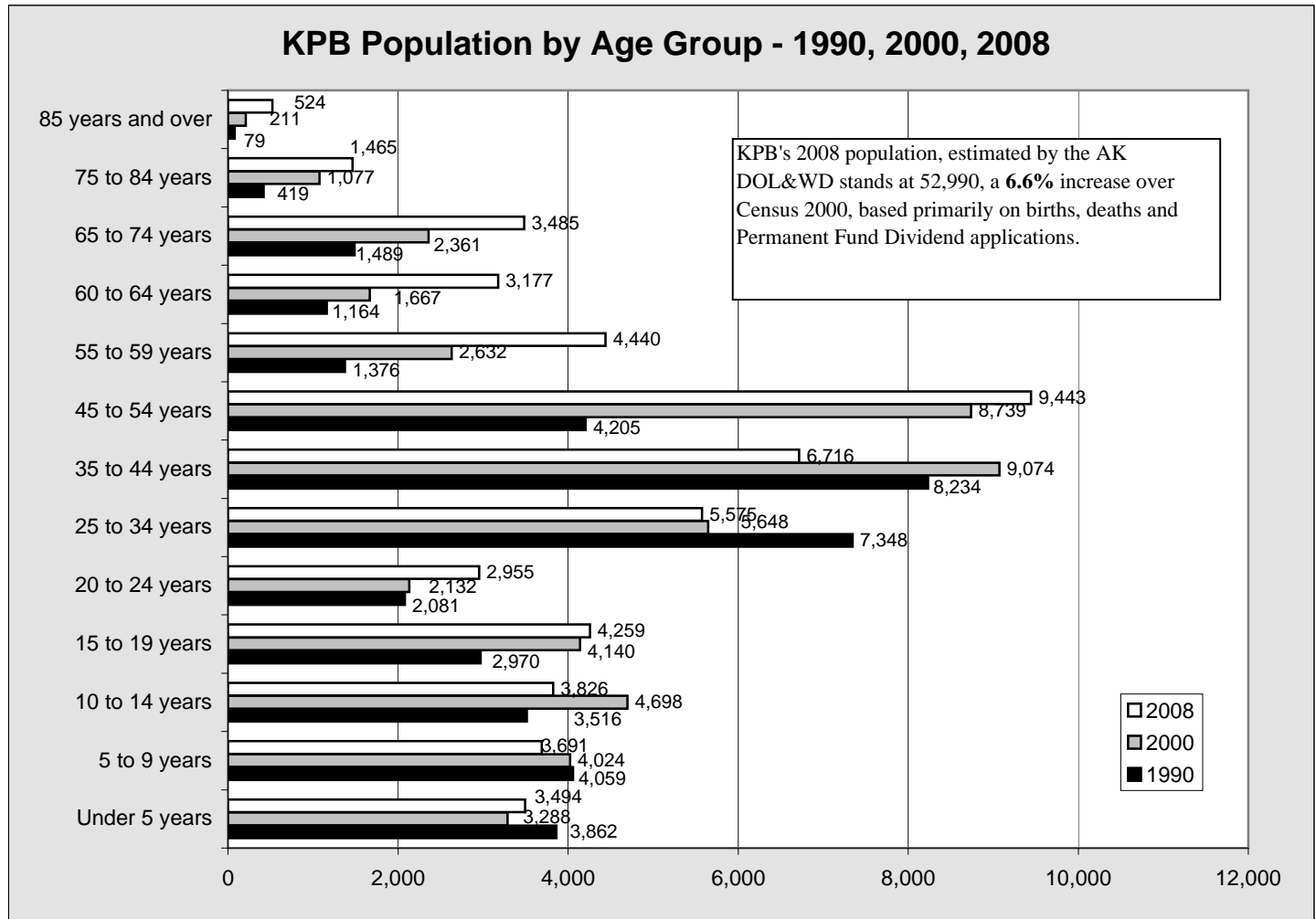

Chart 1.46

KPB Demographics

Percentage Change of Population By Age Cohort - 2000-2008						
Age	Kenai Peninsula Borough	Municipality of Anchorage	Fairbanks Northstar Borough	Juneau Borough	Matanuska-Susitna Borough	State of Alaska
0-4	6.3%	15.8%	22.1%	3.8%	61.5%	15.9%
5-9	-8.8%	2.8%	5.3%	-13.8%	25.6%	0.7%
10-14	-18.6%	1.8%	-9.7%	-19.6%	12.6%	-6.1%
15-19	2.9%	14.3%	0.3%	-0.8%	30.7%	10.7%
20-24	38.6%	14.0%	-5.2%	4.7%	77.1%	13.9%
25-29	0.6%	-0.8%	1.4%	-6.7%	59.3%	2.1%
30-34	-2.9%	-1.9%	8.1%	-19.4%	36.0%	-1.6%
35-39	-22.3%	-11.6%	-8.5%	-23.7%	8.6%	-14.9%
40-44	-29.3%	-13.3%	-15.5%	-25.2%	-7.1%	-17.7%
45-49	-11.2%	5.0%	0.4%	-11.2%	23.2%	0.9%
50-54	33.9%	26.5%	29.5%	13.6%	79.3%	28.5%
55-59	68.7%	54.3%	76.5%	69.4%	106.7%	60.6%
60-64	90.6%	73.6%	93.1%	83.8%	105.6%	75.4%
65-69	69.1%	42.3%	61.7%	68.8%	82.8%	51.1%
70-74	20.8%	19.1%	25.1%	15.7%	44.5%	20.9%
75-79	19.7%	20.7%	21.9%	0.8%	59.6%	21.4%
80-84	71.3%	49.4%	46.4%	12.9%	99.4%	47.8%
85-90	148.1%	70.1%	69.5%	53.9%	128.1%	70.5%
90+	98.8%	85.8%	108.0%	92.6%	149.2%	87.8%
Overall Change	6.7%	9.5%	8.5%	-0.9%	39.1%	10.5%
Median Age in Years						
2000	36.3	32.4	29.5	35.3	34.1	32.4
2008	39.2	33.2	31.4	38.1	34.2	33.5

Table 1.62

Note that from 2000 to 2008, three of the five boroughs illustrated experienced a population decrease in the 10-14 year age group, while five of five areas experienced population decline in the 40-44 year age group.

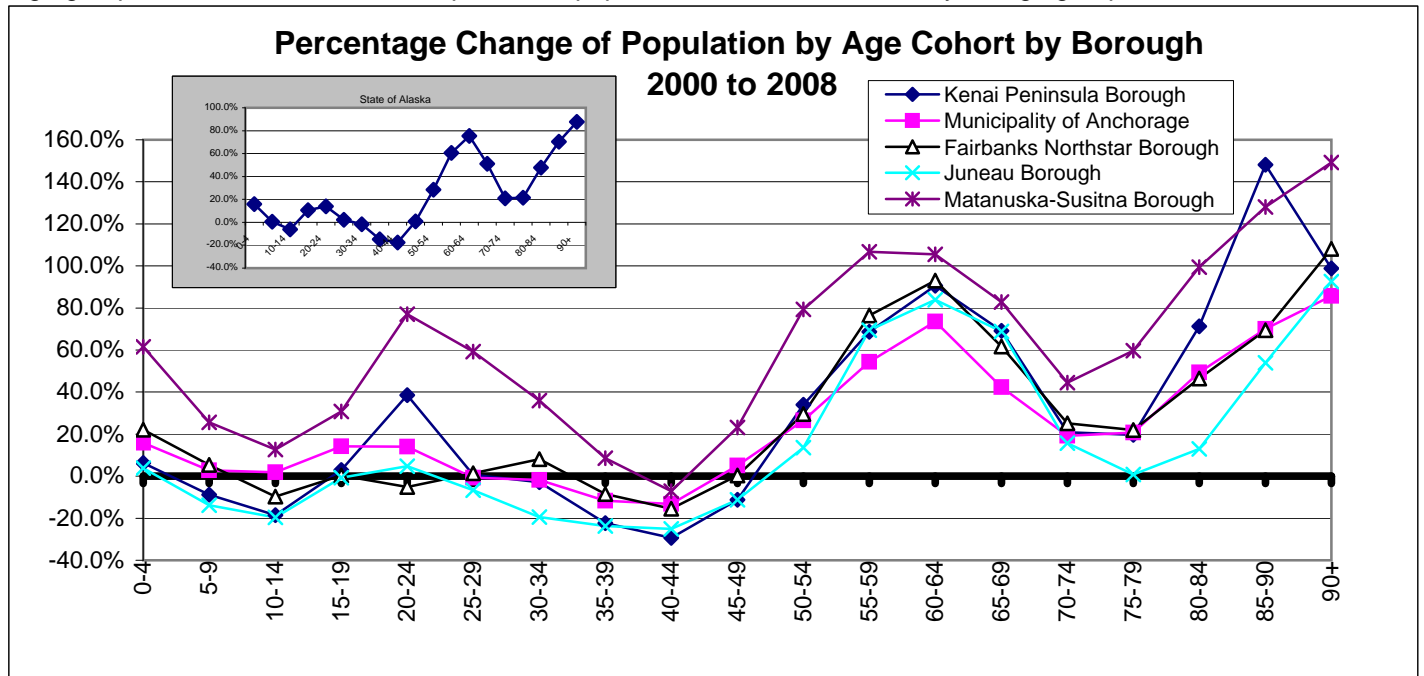

Chart 1.47

Note that Alaska follows the same aging trend. See inset.

KPB Demographics

KPB Select Detail - 1990 v 2000									
Population (2007 estimate - 52,407)					Housing				
	1990	2000	Percent Change	Percent of Total		1990	2000	Percent Change	Percent of Total
Total Population	40,802	49,691	21.8%	100.0%	Total Households	14,250	18,438	29.4%	100.0%
Male	21,606	25,853	19.7%	52.0%	Family Households	10,216	12,716	24.5%	69.0%
Female	19,196	23,838	24.2%	48.0%	With Children Under 18		7,003	NA	38.0%
Under 5 years	3,795	3,288	-13.4%	6.6%	Married Couple Family	8,456	10,218	20.8%	55.4%
5 to 9 years	4,104	4,024	-1.9%	8.1%	With Own Children Under 18		5,133	NA	27.8%
10 to 14 years	3,505	4,698	34.0%	9.5%	Female Householder, no husband present		1,654	NA	9.0%
15 to 19 years	2,939	4,140	40.9%	8.3%	With Own Children Under 18		1,276	NA	6.9%
20 to 24 years	2,086	2,132	2.2%	4.3%	Average Household Size	2.79	2.62	-6.1%	0.0%
25 to 34 years	7,281	5,648	-22.4%	11.4%	Average Family Size		3.15	NA	0.0%
35 to 44 years	8,229	9,074	10.3%	18.3%	Total Housing Units	19,364	24,871	NA	100.0%
45 to 54 years	4,280	8,739	104.2%	17.6%	Occupied Housing Units	14,250	18,438	29.4%	74.1%
55 to 59 years	1,387	2,632	89.8%	5.3%	Vacant Housing Units	5,114	6,433	25.8%	25.9%
60 to 64 years	1,181	1,667	41.2%	3.4%	Seasonal, Recreational, Occasional Use	2,819	4,560	61.8%	18.3%
65 to 74 years	1,503	2,361	57.1%	4.8%	Owner Vacancy Rate	4.1%	2.9%	NA	NA
75 to 84 years	431	1,077	149.9%	2.2%	Rental Vacancy Rate	13.9%	14.4%	NA	NA
85 years and over	81	211	160.5%	0.4%	Owner Occupied Units	9,677	13,585	40.4%	54.6%
Median Age	31.1	36.3	16.7%	NA	Renter Occupied Units	4,573	4,853	6.1%	19.5%
18 Years and Over	13,396	34,832	160.0%	70.1%	Marital Status (over 15)		37,696	NA	100.0%
Male		18,239	NA	NA	Never married		8,829	NA	23.4%
Female		16,593	NA	NA	Married except separated		22,022	NA	58.4%
65 Years and Over	2,015	3,649	81.1%	7.3%	Separated		698	NA	1.9%
Male		1,765	NA	NA	Widowed		1,330	NA	3.5%
Female		1,884	NA	NA	Divorced		4,817	NA	12.8%
Place of Birth					Disabled, Noninstitutionalized				
U.S. Native	39,726	48,335	21.7%	97.3%	Population 5 to 20		13,244	NA	100.0%
Born in Alaska		17,440	NA	35.1%	With a Disability		842	NA	6.4%
Born in other state		30,444	NA	61.3%	Population 21 to 64		28,547	NA	100.0%
Foreign Born	1,076	1,356	26.0%	2.7%	With a Disability		4,843	NA	17.0%
Naturalized Citizen		872	NA	1.8%	Percent Employed		45.4%	NA	45.4%
Not a Citizen		484	NA	1.0%	Without a Disability		23,704	NA	83.0%
Veteran Status					Income in 1999 - Families				
Civilian veterans	5,335	5,941	11.4%	17.1%	Total		12,736		
Educational Attainment					Less than \$10,000	604	602	-0.3%	4.7%
Population 25 years and over				31,388	\$10,000 - \$14,999	548	512	-6.6%	4.0%
Less than 9th grade	934	985	5.5%	3.1%	\$15,000 - \$24,999	1,177	1,248	6.0%	9.8%
9th-12th, no diploma	2,185	2,620	19.9%	8.3%	\$25,000 - \$34,999	1,151	1,396	21.3%	11.0%
High School Diploma	8,560	9,990	16.7%	31.8%	\$35,000 - \$49,999	1,895	1,970	4.0%	15.5%
College, no degree	6,581	9,492	44.2%	30.2%	\$50,000 - \$74,999	2,688	3,148	17.1%	24.7%
Associate Degree	1,789	1,939	8.4%	6.2%	\$75,000 - \$99,999	1,361	1,855	36.3%	14.6%
Bachelor's Degree	3,165	4,254	34.4%	13.6%	\$100,000 - \$149,999	687	1,561	127.2%	12.3%
Graduate, Profess Degr	1,209	2,108	74.4%	6.7%	\$150,000 - \$199,999	279	245	-12.2%	1.9%
Percent HS Grad	87.2%	88.5%	1.5%	NA	\$200,000 or more	NA	199	NA	1.6%
Percent Bachelor's +	17.9%	20.3%	13.4%	NA	Median Income - \$	48,339	54,106	11.9%	NA

Table 1.63

HOMER

Homer Sales

Homer Second Quarter GROSS Sales by Line of Business - 2004-2009 - in \$								
LOB	2004	2005	2006	2007	2008	2009	Annual Percent Change	Annual Amount Change
PROD	334,560	133,823	124,507	106,766	75,172	83,518	11.1%	8,346
SALES	25,963,897	27,858,440	28,007,404	29,411,169	33,745,784	32,723,154	-3.0%	-1,022,630
CONST	5,220,591	11,142,686	7,245,724	10,216,524	8,124,580	5,024,491	-38.2%	-3,100,089
PROP	3,063,819	3,208,860	3,465,548	4,413,029	4,747,221	3,702,945	-22.0%	-1,044,276
TOUR	7,422,768	7,843,290	10,144,672	10,068,430	8,901,554	6,140,468	-31.0%	-2,761,086
SERV	8,034,913	8,441,271	11,653,988	13,087,722	14,755,603	14,414,772	-2.3%	-340,831
PROF	2,567,836	2,064,840	2,207,945	2,399,254	2,131,699	2,661,857	24.9%	530,158
UTIL	8,063,880	8,517,405	10,115,928	11,107,659	9,615,450	13,523,474	40.6%	3,908,024
MANU	1,300,740	1,291,713	1,826,125	2,065,820	2,202,875	1,998,445	-9.3%	-204,430
TRAN	4,910,766	5,568,841	3,383,697	3,363,087	4,876,818	3,404,524	-30.2%	-1,472,294
WHLS	7,924,271	9,153,665	10,146,228	10,083,265	13,001,357	11,264,547	-13.4%	-1,736,810
GOV	944,173	961,634	1,022,191	991,182	1,036,947	1,115,264	7.6%	78,317
TOTAL	75,752,214	86,186,468	89,343,957	97,313,907	103,215,060	96,057,459	-6.9%	-7,157,601

Table 2.1

For complete listing of Lines of Business, see page 17

Homer Second Quarter GROSS Sales History	
2004	75,752,214
2005	86,186,468
2006	89,343,957
2007	97,313,907
2008	103,215,060
2009	96,057,459

Table 2.2

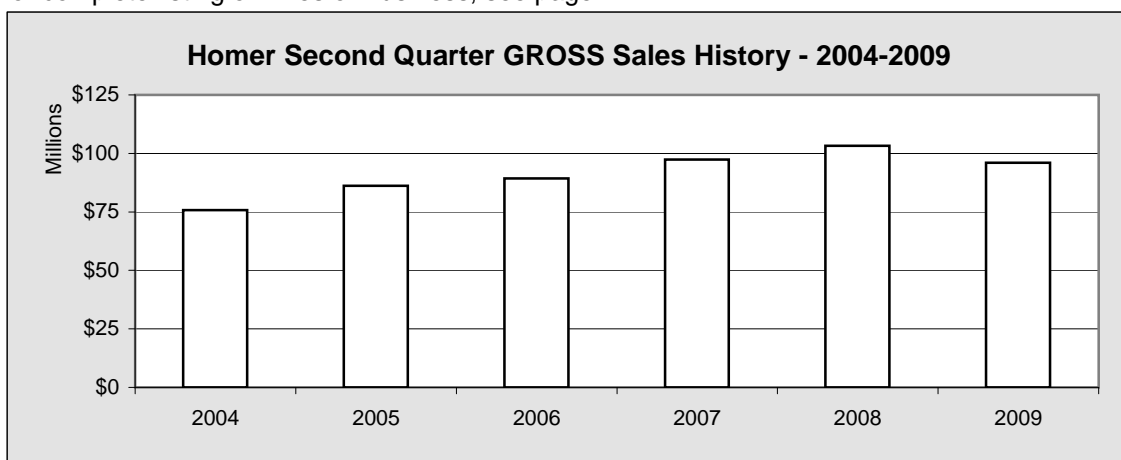

Chart 2.1

Homer Five Year Change Second Quarter GROSS Sales		
LOB	2004	2009
PROD	334,560	83,518
SALES	25,963,897	32,723,154
CONST	5,220,591	5,024,491
PROP	3,063,819	3,702,945
TOUR	7,422,768	6,140,468
SERV	8,034,913	14,414,772
PROF	2,567,836	2,661,857
UTIL	8,063,880	13,523,474
MANU	1,300,740	1,998,445
TRAN	4,910,766	3,404,524
WHLS	7,924,271	11,264,547
GOV	944,173	1,115,264
TOTAL	75,752,214	96,057,459

Table 2.3

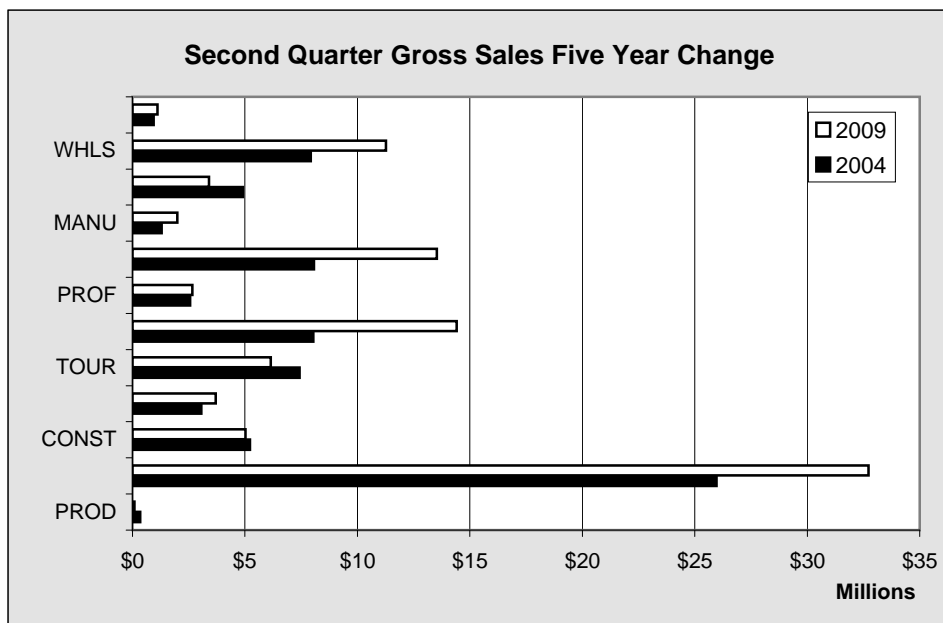

Chart 2.2

Homer Sales

Homer Second Quarter TAXABLE Sales by Line of Business - 2004-2009 - in \$								
LOB	2004	2005	2006	2007	2008	2009	Annual Percent Change	Annual Amount Change
PROD	44,850	43,432	56,938	53,232	59,337	67,021	12.9%	7,684
SALES	18,391,961	19,321,269	19,883,372	21,415,210	25,188,641	20,115,288	-20.1%	-5,073,353
CONST	290,859	264,244	251,082	275,777	358,110	233,642	-34.8%	-124,468
PROP	1,595,660	1,398,598	1,541,232	1,817,662	2,193,127	1,997,252	-8.9%	-195,875
TOUR	6,806,280	7,181,866	8,806,311	8,951,145	7,183,236	5,044,487	-29.8%	-2,138,749
SERV	3,983,736	4,008,387	4,226,384	5,234,465	5,259,295	5,015,966	-4.6%	-243,329
PROF	652,134	624,848	739,680	764,498	763,674	685,325	-10.3%	-78,349
UTIL	782,310	938,525	1,006,828	1,029,995	1,147,715	1,307,919	14.0%	160,204
MANU	346,598	295,430	345,514	485,905	480,290	449,432	-6.4%	-30,858
TRAN	2,221,452	2,359,692	1,232,621	1,573,128	199,534	165,434	-17.1%	-34,100
WHLS	3,588,511	4,094,900	4,302,775	4,595,812	5,001,690	4,065,311	-18.7%	-936,379
GOV	944,173	961,634	996,266	991,182	1,036,947	1,115,264	7.6%	78,317
TOTAL	39,648,524	41,492,825	43,389,003	47,188,011	48,871,596	40,262,341	-17.6%	-8,609,255

Table 2.4 For complete listing of Lines of Business, see page 17

Homer Second Quarter TAXABLE Sales History	
2004	39,648,524
2005	41,492,825
2006	43,389,003
2007	47,188,011
2008	48,871,596
2009	40,262,341

Table 2.5

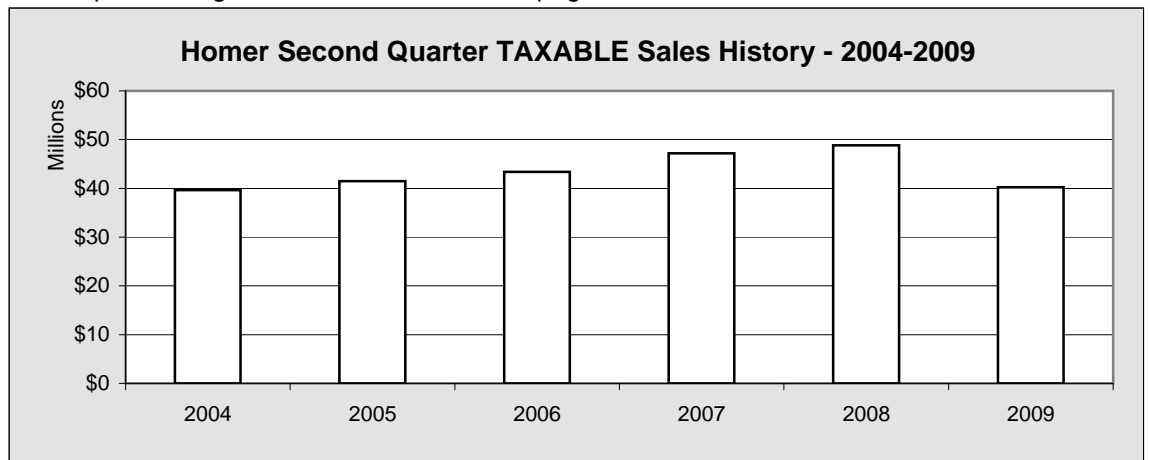

Chart 2.3

Homer Five Year Change Second Quarter TAXABLE Sales		
LOB	2004	2009
PROD	44,850	67,021
SALES	18,391,961	20,115,288
CONST	290,859	233,642
PROP	1,595,660	1,997,252
TOUR	6,806,280	5,044,487
SERV	3,983,736	5,015,966
PROF	652,134	685,325
UTIL	782,310	1,307,919
MANU	346,598	449,432
TRAN	2,221,452	165,434
WHLS	3,588,511	4,065,311
GOV	944,173	1,115,264
TOTAL	39,648,524	40,262,341

Table 2.6

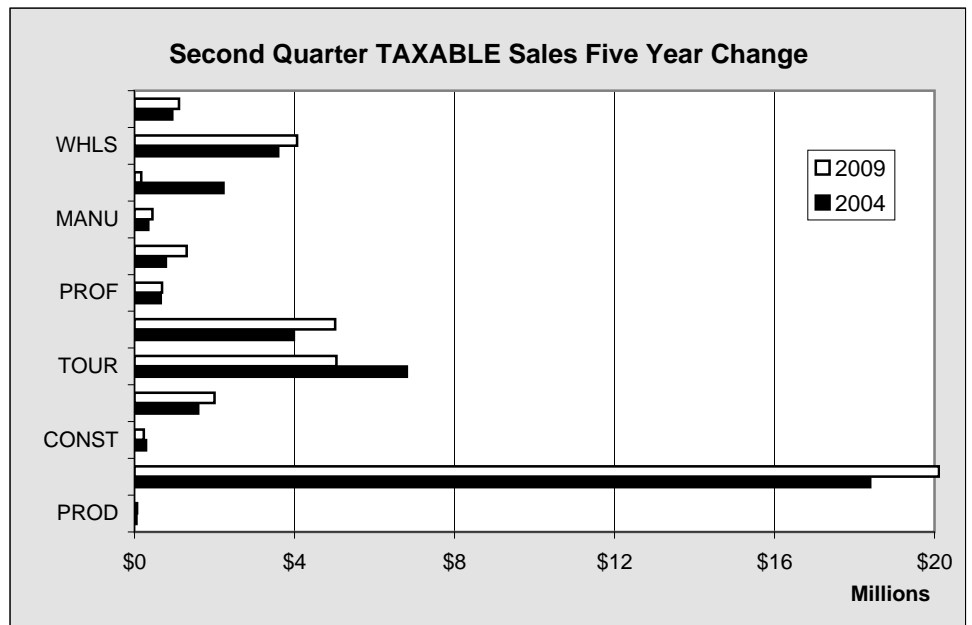

Chart 2.4

Homer Sales

Homer YTD June 30 GROSS Sales by Line of Business - 2004-2009 - in \$								
LOB	2004	2005	2006	2007	2008	2009	Annual Percent Change	Annual Amount Change
PROD	573,528	196,344	156,286	143,568	87,611	106,431	21.5%	18,820
SALES	42,029,059	44,859,704	45,549,788	46,824,003	54,651,347	52,178,511	-4.5%	-2,472,836
CONST	9,179,582	16,215,361	11,719,393	17,035,027	14,683,487	9,810,370	-33.2%	-4,873,117
PROP	5,762,549	5,692,690	6,029,091	7,269,885	8,415,865	6,560,366	-22.0%	-1,855,499
TOUR	10,702,593	11,169,280	13,822,618	13,759,426	10,747,577	7,704,503	-28.3%	-3,043,074
SERV	12,756,355	13,866,247	18,281,333	19,839,959	21,698,775	20,673,379	-4.7%	-1,025,396
PROF	4,660,464	3,928,060	3,999,868	4,959,856	3,981,153	4,306,278	8.2%	325,125
UTIL	15,504,040	16,901,792	20,534,202	22,603,816	20,067,645	29,116,422	45.1%	9,048,777
MANU	2,130,730	1,863,494	2,867,636	3,329,029	3,576,501	3,134,979	-12.3%	-441,522
TRAN	5,864,144	6,667,903	4,093,517	4,057,546	7,698,723	7,160,484	-7.0%	-538,239
WHLS	13,146,468	15,090,821	16,830,230	17,301,439	21,630,558	19,051,208	-11.9%	-2,579,350
GOV	1,584,288	1,616,417	1,635,721	1,603,126	1,683,936	1,766,322	4.9%	82,386
TOTAL	123,893,800	138,068,113	145,519,683	158,726,680	168,923,178	161,569,253	-4.4%	-7,353,925

Table 2.7

For complete listing of Lines of Business, see page 17

Homer YTD June 30 GROSS Sales History	
2004	123,893,800
2005	138,068,113
2006	145,519,683
2007	158,726,680
2008	168,923,178
2009	161,569,253

Table 2.8

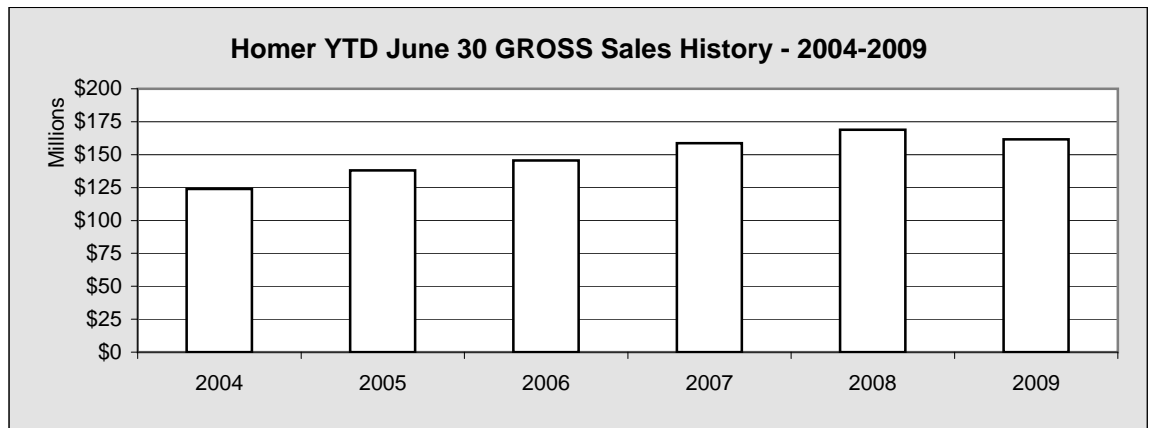

Chart 2.5

Homer Five Year Change YTD June 30 GROSS Sales		
	2004	2009
PROD	573,528	106,431
SALES	42,029,059	52,178,511
CONST	9,179,582	9,810,370
PROP	5,762,549	6,560,366
TOUR	10,702,593	7,704,503
SERV	12,756,355	20,673,379
PROF	4,660,464	4,306,278
UTIL	15,504,040	29,116,422
MANU	2,130,730	3,134,979
TRAN	5,864,144	7,160,484
WHLS	13,146,468	19,051,208
GOV	1,584,288	1,766,322
TOTAL	123,893,800	161,569,253

Table 2.9

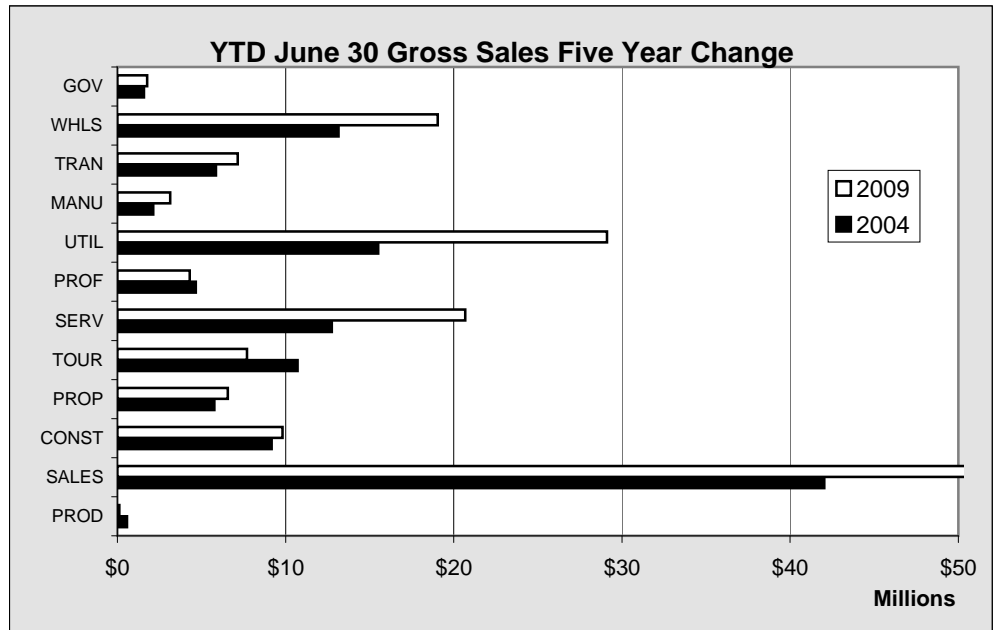

Chart 2.6

Homer Sales

Homer YTD June 30 TAXABLE Sales by Line of Business - 2004-2009 - in \$

LOB	2004	2005	2006	2007	2008	2009	Annual Percent Change	Annual Amount Change
PROD	52,636	55,609	58,873	57,489	62,616	69,303	10.7%	6,687
SALES	30,099,716	31,196,961	32,304,072	34,515,043	41,012,306	29,952,472	-27.0%	-11,059,834
CONST	489,794	443,396	435,127	462,794	643,499	438,724	-31.8%	-204,775
PROP	2,749,233	2,530,717	2,677,378	2,979,387	3,540,715	3,373,487	-4.7%	-167,228
TOUR	9,713,949	10,164,569	12,108,877	12,300,908	8,724,576	6,328,057	-27.5%	-2,396,519
SERV	7,002,705	6,962,593	7,361,475	8,538,594	9,035,529	8,653,066	-4.2%	-382,463
PROF	1,247,229	1,235,940	1,330,481	1,403,460	1,490,082	1,331,750	-10.6%	-158,332
UTIL	1,697,819	1,956,268	2,286,807	2,382,333	2,414,246	3,138,296	30.0%	724,050
MANU	525,700	435,417	508,604	685,111	701,722	669,397	-4.6%	-32,325
TRAN	2,495,879	2,674,164	1,374,808	1,680,903	321,916	274,798	-14.6%	-47,118
WHLS	5,814,496	6,554,017	7,057,685	7,830,305	8,263,370	6,856,163	-17.0%	-1,407,207
GOV	1,584,288	1,616,417	1,609,796	1,603,126	1,683,936	1,766,322	4.9%	82,386
TOTAL	63,473,444	65,826,068	69,113,983	74,439,453	77,894,513	62,851,835	-19.3%	-15,042,678

Table 2.10

For complete listing of Lines of Business, see page 17

Homer YTD June 30 TAXABLE Sales History	
2004	63,473,444
2005	65,826,068
2006	69,113,983
2007	74,439,453
2008	77,894,513
2009	62,851,835

Table 2.11

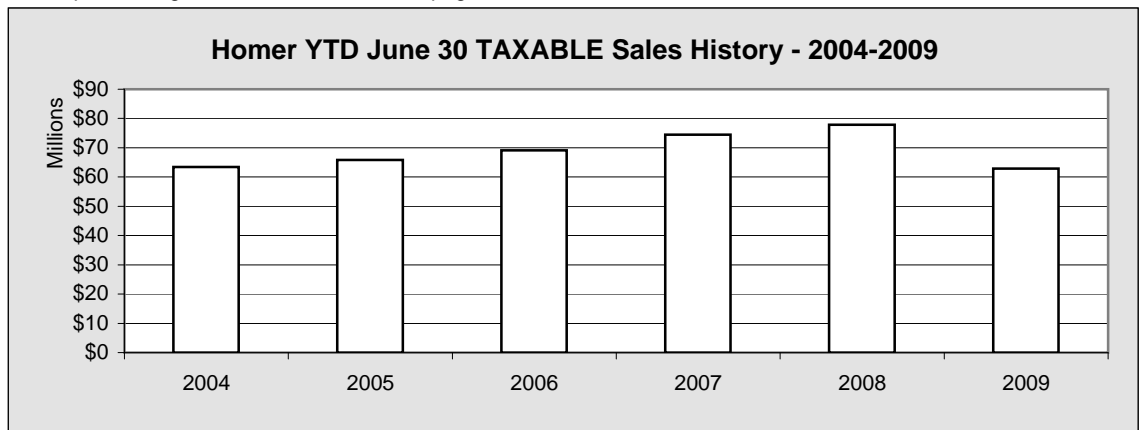

Chart 2.7

Homer Five Year Change YTD June 30 TAXABLE Sales		
	2004	2009
PROD	52,636	69,303
SALES	30,099,716	29,952,472
CONST	489,794	438,724
PROP	2,749,233	3,373,487
TOUR	9,713,949	6,328,057
SERV	7,002,705	8,653,066
PROF	1,247,229	1,331,750
UTIL	1,697,819	3,138,296
MANU	525,700	669,397
TRAN	2,495,879	274,798
WHLS	5,814,496	6,856,163
GOV	1,584,288	1,766,322
TOTAL	63,473,444	62,851,835

Table 2.12

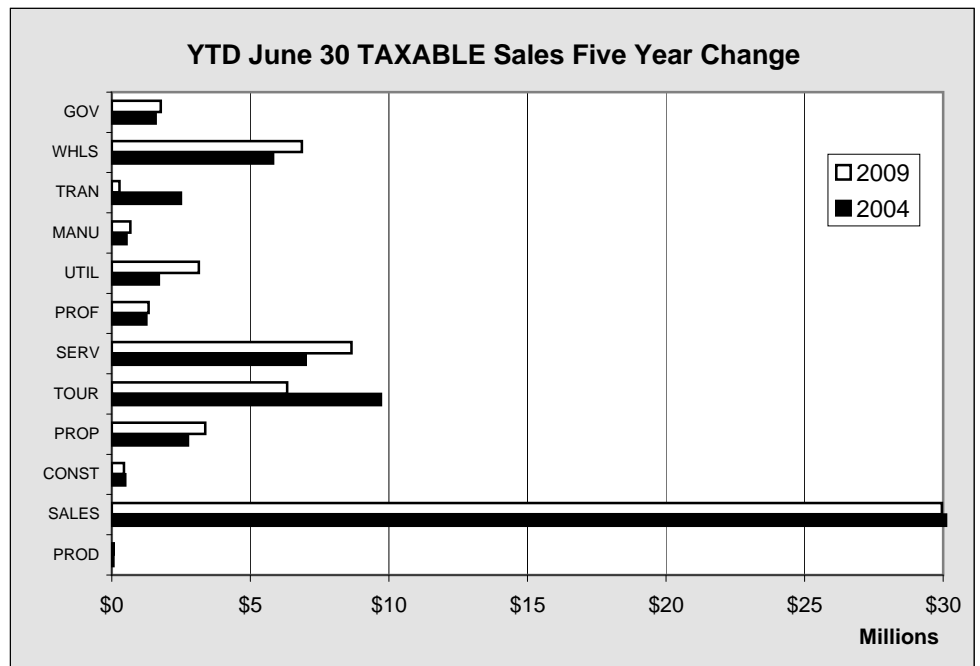

Chart 2.8

Homer Sales

Homer Annual GROSS Sales by Line of Business - 2003-2008 - in \$

LOB	2003	2004	2005	2006	2007	2008	Annual Percent Change	Annual Amount Change
PROD	591,515	578,112	401,509	369,100	2,365,868	179,854	-92.4%	-2,186,014
SALES	86,594,152	92,094,391	95,289,498	100,483,770	105,875,605	120,051,673	13.4%	14,176,068
CONST	41,476,625	32,025,640	37,661,154	56,046,199	42,882,913	39,327,058	-8.3%	-3,555,855
PROP	12,052,352	13,854,382	13,270,084	14,176,548	16,845,079	18,414,506	9.3%	1,569,427
TOUR	30,616,944	34,850,502	36,775,040	39,661,724	39,520,368	28,543,766	-27.8%	-10,976,602
SERV	25,280,522	27,233,603	29,901,849	35,427,278	41,862,709	43,756,755	4.5%	1,894,046
PROF	10,502,846	10,856,028	9,166,842	8,946,338	10,191,987	9,097,321	-10.7%	-1,094,666
UTIL	27,145,942	31,642,148	34,464,246	43,313,320	35,617,604	45,870,728	28.8%	10,253,124
MANU	5,613,784	5,420,061	5,923,968	6,236,271	7,469,355	7,088,639	-5.1%	-380,716
TRAN	4,104,423	5,200,713	4,445,884	5,653,305	8,718,520	19,402,676	122.5%	10,684,156
WHLS	26,430,585	32,846,550	38,020,032	41,916,295	37,993,258	46,931,310	23.5%	8,938,052
GOV	3,664,092	3,821,622	3,948,647	3,997,559	4,108,884	4,250,013	3.4%	141,129
TOTAL	274,073,782	290,423,752	309,268,753	356,227,707	353,452,150	382,914,299	8.3%	29,462,149

Table 2.13

For complete listing of Lines of Business, see page 17

Homer Annual GROSS Sales History	
2003	274,073,782
2004	290,423,752
2005	309,268,753
2006	356,227,707
2007	353,452,150
2008	382,914,299

Table 2.14

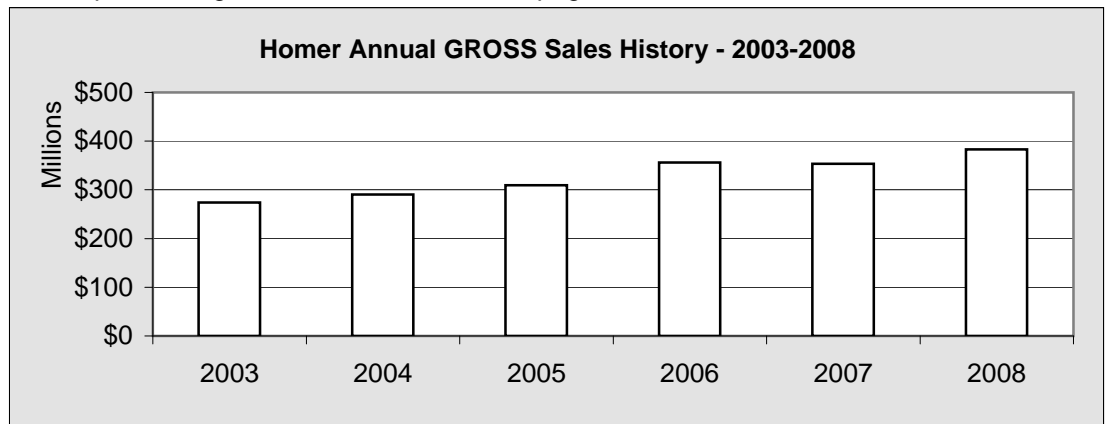

Chart 2.9

Five Year Change Annual GROSS Sales		
LOB	2003	2008
PROD	591,515	179,854
SALES	86,594,152	120,051,673
CONST	41,476,625	39,327,058
PROP	12,052,352	18,414,506
TOUR	30,616,944	28,543,766
SERV	25,280,522	43,756,755
PROF	10,502,846	9,097,321
UTIL	27,145,942	45,870,728
MANU	5,613,784	7,088,639
TRAN	4,104,423	19,402,676
WHLS	26,430,585	46,931,310
GOV	3,664,092	4,250,013
TOTAL	274,073,782	382,914,299

Table 2.15

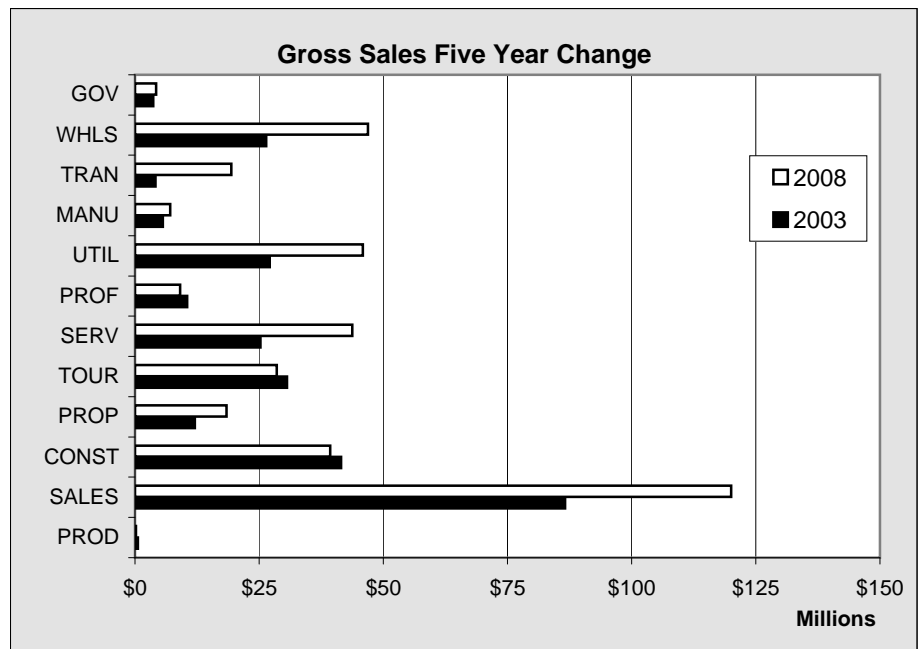

Chart 2.10

Homer Sales

Homer Annual TAXABLE Sales by Line of Business - 2003-2008 - in \$								
LOB	2003	2004	2005	2006	2007	2008	Annual Percent Change	Annual Amount Change
PROD	81,146	98,715	114,749	118,806	131,974	111,890	-15.2%	-20,084
SALES	61,814,637	64,566,619	65,900,008	70,072,643	75,219,488	88,639,102	17.8%	13,419,614
CONST	1,195,200	1,047,393	1,001,934	1,005,362	1,135,005	1,501,889	32.3%	366,884
PROP	5,690,743	6,300,936	5,972,735	6,274,656	7,437,109	7,987,267	7.4%	550,158
TOUR	25,461,636	28,294,331	29,762,284	31,954,906	33,470,820	23,196,100	-30.7%	-10,274,720
SERV	14,037,667	14,612,060	14,799,085	15,112,276	18,205,719	18,898,404	3.8%	692,685
PROF	2,504,002	2,533,505	2,411,633	2,831,562	3,004,851	2,886,153	-4.0%	-118,698
UTIL	3,561,037	3,464,301	3,855,271	4,456,860	4,496,375	4,886,007	8.7%	389,632
MANU	1,276,489	1,267,771	1,121,485	1,149,768	1,567,291	1,581,031	0.9%	13,740
TRAN	1,101,874	717,019	679,313	735,429	624,681	704,654	12.8%	79,973
WHLS	11,340,673	13,251,309	15,190,505	15,733,320	17,128,509	18,385,963	7.3%	1,257,454
GOV	3,644,092	3,821,622	3,948,647	3,939,804	4,079,127	4,232,334	3.8%	153,207
TOTAL	131,709,196	139,975,581	144,757,649	153,385,392	166,500,949	173,010,794	3.9%	6,509,845

Table 2.16

For complete listing of Lines of Business, see page 17

Homer Annual TAXABLE Sales History	
2003	131,709,196
2004	139,975,581
2005	144,757,649
2006	153,385,392
2007	166,500,949
2008	173,010,794

Table 2.17

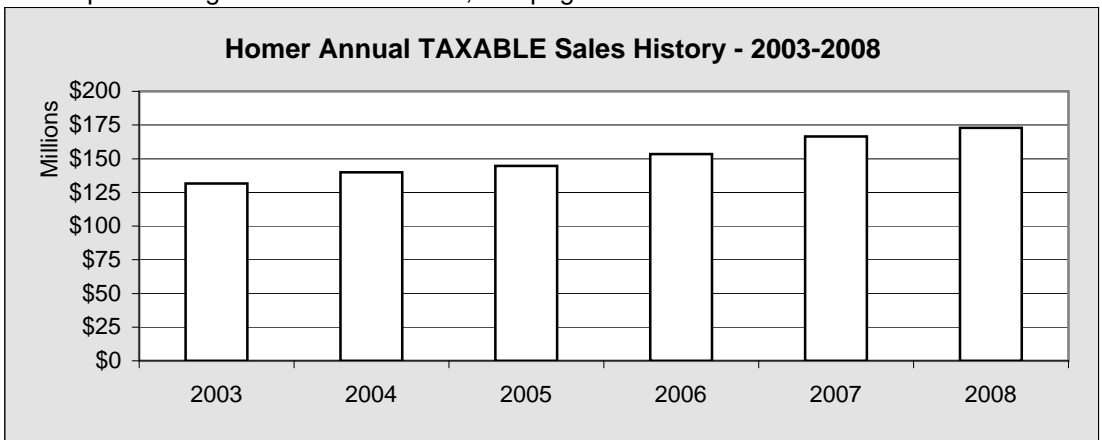
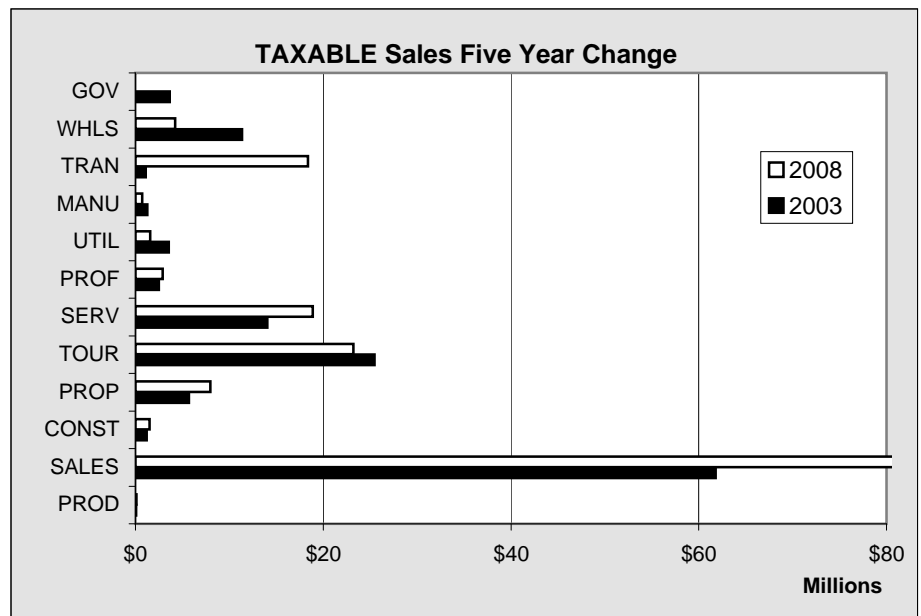

Chart 2.11

Five Year Change Annual TAXABLE Sales		
LOB	2003	2008
PROD	81,146	111,890
SALES	61,814,637	88,639,102
CONST	1,195,200	1,501,889
PROP	5,690,743	7,987,267
TOUR	25,461,636	23,196,100
SERV	14,037,667	18,898,404
PROF	2,504,002	2,886,153
UTIL	3,561,037	1,581,031
MANU	1,276,489	704,654
TRAN	1,101,874	18,385,963
WHLS	11,340,673	4,232,334
GOV	3,644,092	#REF!
TOTAL	131,709,196	173,010,794

Table 2.18

Chart 2.12



Homer Sales

Homer GROSS Sales by Line of Business by Quarter - 2008 - in \$					
	1st Quarter	2nd Quarter	3rd Quarter	4th Quarter	Total
Resource Production	12,439	75,172	55,339	36,904	179,854
Sales	20,905,563	33,745,784	39,479,740	25,920,586	120,051,673
Construction	6,558,907	8,124,580	10,386,248	14,257,323	39,327,058
Property	3,668,644	4,747,221	5,850,457	4,148,184	18,414,506
Tourism	1,846,023	8,901,554	15,617,028	2,179,161	28,543,766
Services	6,943,172	14,755,603	13,317,561	8,740,419	43,756,755
Professional	1,849,454	2,131,699	2,308,155	2,808,013	9,097,321
Utility	10,452,195	9,615,450	11,557,324	12,245,759	43,870,728
Manufacturing	1,373,626	2,202,875	2,133,009	1,379,129	7,088,639
Transporation & Warehousing	2,821,905	4,876,818	7,125,075	4,578,878	19,402,676
Wholesale	8,629,201	13,001,357	16,373,406	8,927,346	46,931,310
Government	646,989	1,036,947	1,751,954	814,123	4,250,013
TOTAL	65,708,118	103,215,060	125,955,296	86,035,825	380,914,299

Table 2.19

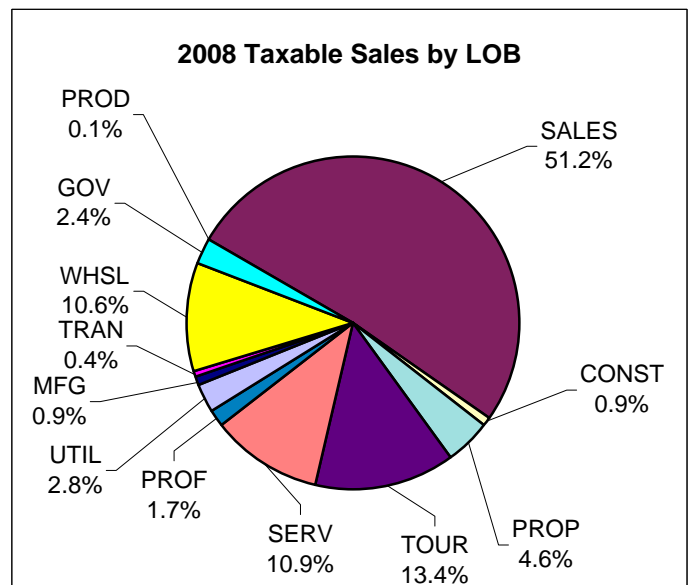
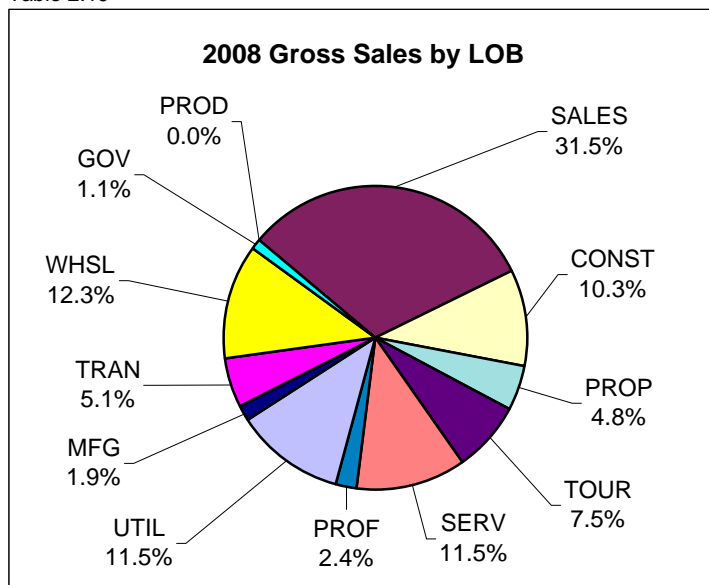

Chart 2.13

Chart 2.14

Homer TAXABLE Sales by Line of Business by Quarter - 2008 - in \$					
LOB	1st Quarter	2nd Quarter	3rd Quarter	4th Quarter	Total
Resource Production	3,279	59,337	35,874	13,400	111,890
Sales	15,823,665	25,188,641	29,277,963	18,348,833	88,639,102
Construction	285,389	358,110	414,430	443,960	1,501,889
Property	1,347,588	2,193,127	2,791,796	1,654,756	7,987,267
Tourism	1,541,340	7,183,236	13,035,544	1,435,980	23,196,100
Services	3,776,234	5,259,295	6,116,028	3,746,847	18,898,404
Professional	726,408	763,674	718,825	677,246	2,886,153
Utility	1,266,531	1,147,715	1,092,699	1,379,062	4,886,007
Manufacturing	221,432	480,290	592,666	286,643	1,581,031
Transporation & Warehousing	122,382	199,534	256,631	126,107	704,654
Wholesale	3,261,680	5,001,690	6,274,453	3,848,140	18,385,963
Government	646,989	1,036,947	1,734,275	814,123	4,232,334
TOTAL	29,022,917	48,871,596	62,341,184	32,775,097	173,010,794

Table 2.20

Homer Sales

Homer GROSS Sales by Line of Business by Quarter - 2007- in \$					
LOB	1st Quarter	2nd Quarter	3rd Quarter	4th Quarter	Total
Resource Production	36,802	103,362	776,896	1,448,808	2,365,868
Sales	17,449,718	29,434,729	34,037,204	24,953,954	105,875,605
Construction	6,818,503	10,216,524	16,142,373	9,705,513	42,882,913
Property	2,881,498	4,421,535	5,425,103	4,116,943	16,845,079
Tourism	3,680,509	12,253,266	19,771,716	3,814,877	39,520,368
Services	6,758,058	13,105,824	13,659,930	8,338,897	41,862,709
Professional	2,560,602	2,399,254	2,414,679	2,817,452	10,191,987
Utility	11,496,157	11,107,659	1,854,484	11,159,304	35,617,604
Manufacturing	1,263,209	2,065,820	2,339,827	1,800,499	7,469,355
Transporation & Warehousing	649,338	1,096,320	3,838,163	3,134,699	8,718,520
Wholesale	7,218,174	10,095,243	11,847,065	8,832,776	37,993,258
Government	611,944	991,182	1,619,941	885,817	4,108,884
TOTAL	61,424,512	97,290,718	113,727,381	81,009,539	353,452,150

Table 2.21

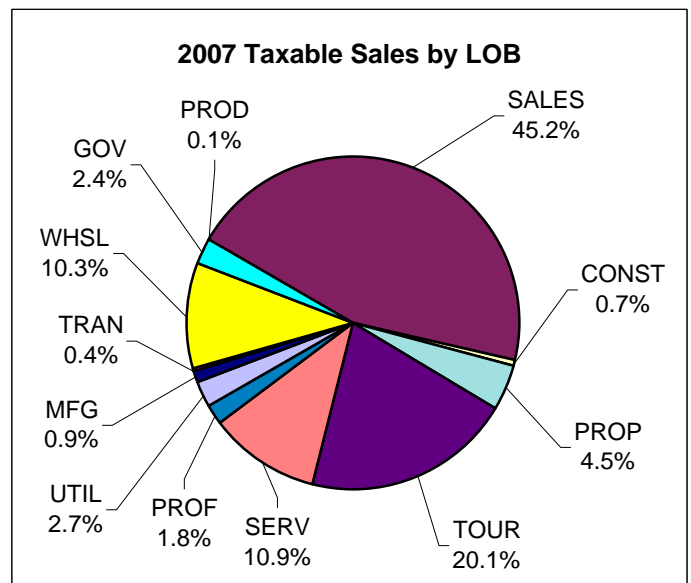
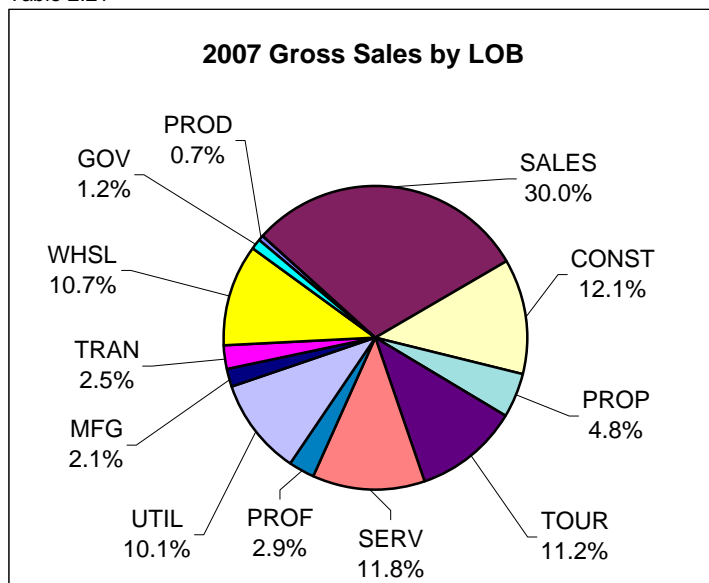

Chart 2.15

Chart 2.16

Homer TAXABLE Sales by Line of Business by Quarter - 2007 - in \$					
LOB	1st Quarter	2nd Quarter	3rd Quarter	4th Quarter	Total
Resource Production	4,257	53,232	50,275	24,210	131,974
Sales	13,136,717	21,438,770	24,027,802	16,616,199	75,219,488
Construction	187,017	275,777	359,963	312,248	1,135,005
Property	1,168,537	1,823,258	2,739,172	1,706,142	7,437,109
Tourism	3,310,379	10,296,241	16,615,854	3,248,346	33,470,820
Services	3,223,344	5,160,491	5,941,426	3,880,458	18,205,719
Professional	718,854	841,092	733,364	711,541	3,004,851
Utility	1,352,338	1,029,995	1,024,372	1,089,670	4,496,375
Manufacturing	199,579	486,717	592,505	288,490	1,567,291
Transporation & Warehousing	107,100	175,667	193,841	148,073	624,681
Wholesale	3,234,493	4,595,812	5,497,301	3,800,903	17,128,509
Government	611,944	991,182	1,590,184	885,817	4,079,127
TOTAL	27,254,559	47,168,234	59,366,059	32,712,097	166,500,949

Table 2.22

Homer Sales

Homer GROSS Sales by Line of Business by Quarter - 2006 - in \$					
LOB	1st Quarter	2nd Quarter	3rd Quarter	4th Quarter	Total
Resource Production	31,679	124,270	137,400	75,751	369,100
Sales	17,557,481	28,040,235	32,132,916	22,753,138	100,483,770
Construction	4,461,809	7,237,619	22,824,100	51,522,671	86,046,199
Property	2,578,348	3,470,648	4,430,532	3,697,020	14,176,548
Tourism	3,648,044	12,389,123	19,852,415	3,772,142	39,661,724
Services	6,625,256	11,644,771	9,249,884	7,907,367	35,427,278
Professional	1,791,923	2,207,945	2,010,147	2,936,323	8,946,338
Utility	10,418,274	10,115,928	10,735,993	12,043,125	43,313,320
Manufacturing	1,041,511	1,826,125	1,806,035	1,562,600	6,236,271
Transporation & Warehousing	703,817	1,052,012	2,545,922	1,351,554	5,653,305
Wholesale	6,685,091	10,183,413	11,198,192	13,849,599	41,916,295
Government	613,530	1,022,191	1,539,571	822,267	3,997,559
TOTAL	56,156,763	89,314,280	118,463,107	122,293,557	386,227,707

Table 2.23

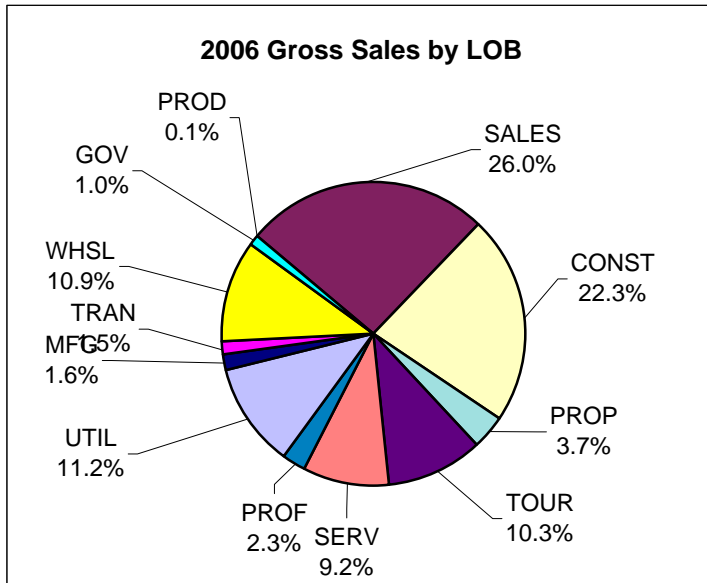

Chart 2.17

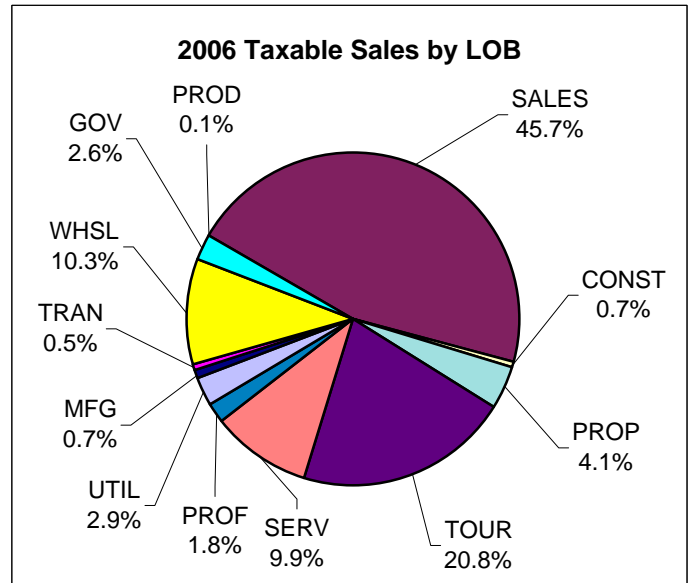

Chart 2.18

Homer TAXABLE Sales by Line of Business by Quarter - 2006 - in \$					
LOB	1st Quarter	2nd Quarter	3rd Quarter	4th Quarter	Total
Resource Production	1,835	56,701	44,215	16,055	118,806
Sales	12,435,797	19,916,203	22,228,321	15,492,322	70,072,643
Construction	183,645	251,319	297,561	272,837	1,005,362
Property	1,139,517	1,549,941	2,178,390	1,406,808	6,274,656
Tourism	3,284,468	9,769,324	15,594,329	3,306,785	31,954,906
Services	3,068,824	4,146,056	4,466,537	3,430,859	15,112,276
Professional	654,433	800,041	699,379	677,709	2,831,562
Utility	1,279,979	1,006,828	926,806	1,243,247	4,456,860
Manufacturing	163,090	345,514	424,052	217,112	1,149,768
Transporation & Warehousing	137,598	227,184	234,471	136,176	735,429
Wholesale	2,754,910	4,302,775	5,234,827	3,440,808	15,733,320
Government	613,530	996,266	1,507,741	822,267	3,939,804
TOTAL	25,717,626	43,368,152	53,836,629	30,462,985	153,385,392

Table 2.24

Homer Sales

Homer Annual Gross Sales by Quarter - in \$						
	1st Quarter	2nd Quarter	3rd Quarter	4th Quarter	Total	Annual Change
1994	31,235,061	42,700,947	58,938,940	38,217,421	171,092,369	
1995	32,193,561	48,092,891	66,559,556	50,757,887	197,603,895	15.5%
1996	40,009,169	53,691,216	60,425,514	45,000,789	199,126,688	0.8%
1997	39,502,354	55,496,297	62,490,851	45,710,368	203,199,870	2.0%
1998	41,054,484	53,702,365	70,866,151	46,799,617	212,422,617	4.5%
1999	39,553,648	53,874,362	66,354,543	44,068,392	203,850,945	-4.0%
2000	38,455,167	59,287,582	90,009,668	48,229,307	235,981,724	15.8%
2001	40,844,978	56,857,475	77,453,956	54,547,098	229,703,507	-2.7%
2002	44,269,653	68,675,179	89,708,860	60,586,992	263,240,684	14.6%
2003	51,228,276	75,287,944	87,226,845	60,330,717	274,073,782	4.1%
2004	48,145,060	75,761,464	93,912,813	72,604,415	290,423,752	6.0%
2005	51,885,093	85,895,824	100,977,789	70,510,047	309,268,753	6.5%
2006	56,156,763	89,314,280	118,463,107	92,293,557	356,227,707	15.2%
2007	61,424,512	97,290,718	113,727,381	81,009,539	353,452,150	-0.8%
2008	65,708,118	103,215,060	125,955,296	88,035,825	382,914,299	8.3%
2009	65,511,794	96,057,459			161,569,253	
Change	-0.3%	-6.9%				

Table 2.25 * - Effective April 1, 2002, Homer annexed an area that increased it's area by 28%.

Homer Annual Taxable Sales by Quarter - in \$						
	1st Quarter	2nd Quarter	3rd Quarter	4th Quarter	Total	Annual Change
1994	14,062,259	23,814,227	29,434,329	16,734,643	84,045,458	
1995	14,797,530	24,901,076	30,398,162	18,098,624	88,195,392	4.9%
1996	15,811,688	25,240,189	30,539,871	18,331,480	89,923,228	2.0%
1997	16,213,730	25,960,313	31,654,939	19,496,943	93,325,925	3.8%
1998	16,418,580	26,366,097	32,103,748	19,552,917	94,441,342	1.2%
1999	16,638,467	26,939,183	34,246,601	20,325,107	98,149,358	3.9%
2000	17,327,860	28,797,872	35,677,211	21,387,173	103,190,116	5.1%
2001	17,765,204	30,191,477	37,574,702	21,780,156	107,311,539	4.0%
2002	18,699,958	34,270,923	43,258,197	25,063,470	121,292,548	13.0%
2003	22,456,282	37,038,468	45,127,086	27,107,360	131,729,196	8.6%
2004	23,828,394	39,657,774	48,989,881	27,499,532	139,975,581	6.3%
2005	24,336,691	41,201,861	50,641,860	28,577,237	144,757,649	3.4%
2006	25,717,626	43,368,152	53,836,629	30,462,985	153,385,392	6.0%
2007	27,254,559	47,168,234	59,366,059	32,712,097	166,500,949	8.6%
2008	29,022,907	48,871,596	62,341,184	32,775,097	173,010,784	3.9%
2009	22,589,494	40,262,341			62,851,835	
Change	-22.2%	-17.6%				

Table 2.26 * - Effective April 1, 2002, Homer annexed an area that increased it's area by 28%.

Homer Annual Non-Taxable Sales by Quarter - in \$						
	1st Quarter	2nd Quarter	3rd Quarter	4th Quarter	Total	Annual Change
1994	17,172,802	18,886,720	29,504,611	21,482,778	87,046,911	
1995	17,396,031	23,191,815	36,161,394	32,659,263	109,408,503	25.7%
1996	24,197,481	28,451,027	29,885,643	26,669,309	109,203,460	-0.2%
1997	23,288,624	29,535,984	30,835,912	26,213,425	109,873,945	0.6%
1998	24,635,904	27,336,268	38,762,403	27,246,700	117,981,275	7.4%
1999	22,915,181	26,935,179	32,107,942	23,743,285	105,701,587	-10.4%
2000	21,127,307	30,489,710	54,332,457	26,842,134	132,791,608	25.6%
2001	23,079,774	26,665,998	39,879,254	32,766,942	122,391,968	-7.8%
2002	25,569,695	34,404,256	46,450,663	35,523,522	141,948,136	16.0%
2003	28,771,994	38,249,476	42,099,759	33,223,357	142,344,586	0.3%
2004	24,316,666	36,103,690	44,922,932	45,104,883	150,448,171	5.7%
2005	27,548,402	44,693,963	50,335,929	41,932,810	164,511,104	9.3%
2006	30,439,137	45,946,128	64,626,478	61,830,572	202,842,315	23.3%
2007	34,169,953	50,122,484	54,361,322	48,297,442	186,951,201	-7.8%
2008	36,685,211	54,343,464	63,614,112	55,260,728	209,903,515	12.3%
2009	42,922,300	55,795,118				
Change	17.0%	2.7%				

Table 2.27 * - Effective April 1, 2002, Homer annexed an area that increased it's area by 28%.

Homer Construction

Homer 2nd Quarter Permit VALUES by Type - 2003-2009- in \$								
	2003	2004	2005	2006	2007	2008	2009	Annual Change
Residential New	3,811,480	2,495,400	3,072,000	4,250,100	4,760,000	6,488,000	2,215,000	-65.9%
Residential Alter/Add	239,060	205,730	451,000	287,000	482,000	163,000	175,500	7.7%
Commercial New	3,535,720	4,700,518	7,473,000	2,310,000	2,095,001	10,000,000	0	-100.0%
Commercial Alter/Add	343,240	32,063	250,000	620,000	20,000	0	0	0.0%
Total	7,929,500	7,433,711	11,246,000	7,467,100	7,357,001	16,651,000	2,390,500	-85.6%
Annual Change		-6.3%	51.3%	-33.6%	-1.5%	126.3%	-85.6%	

Table 2.28

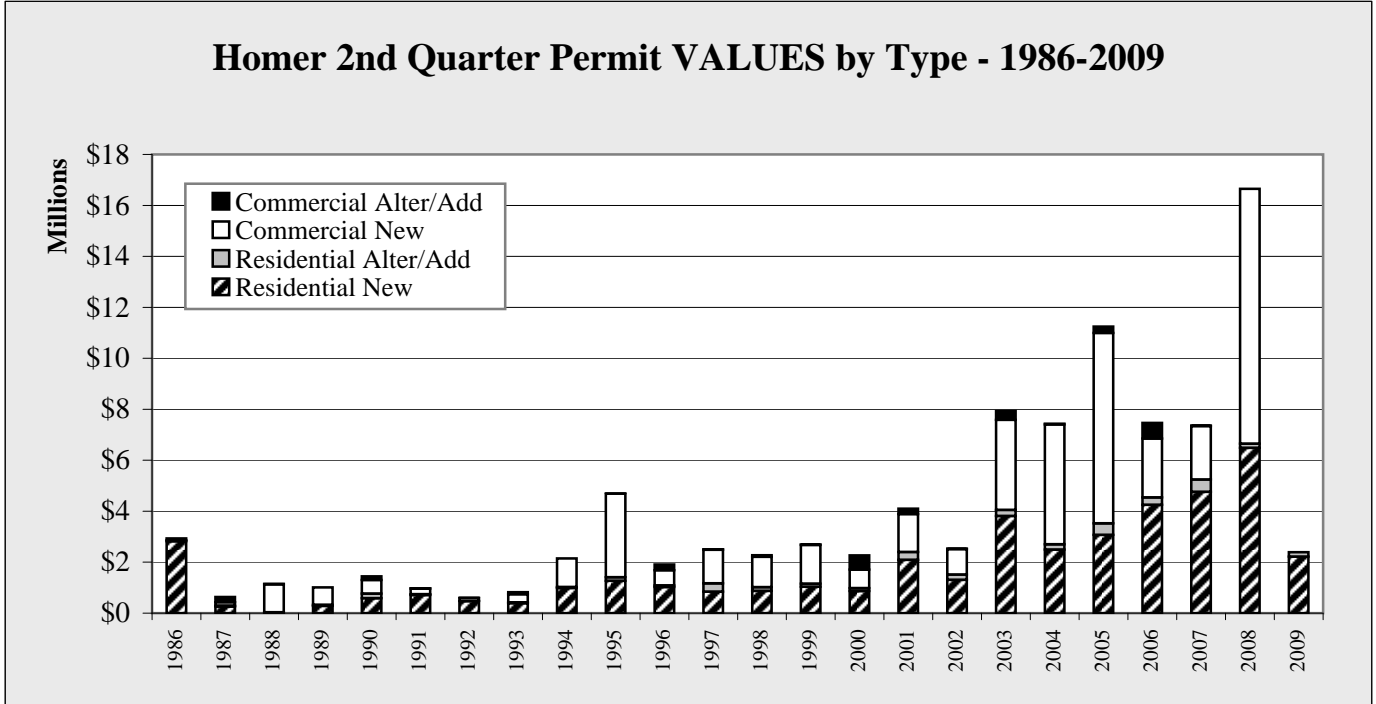

Chart 2.19

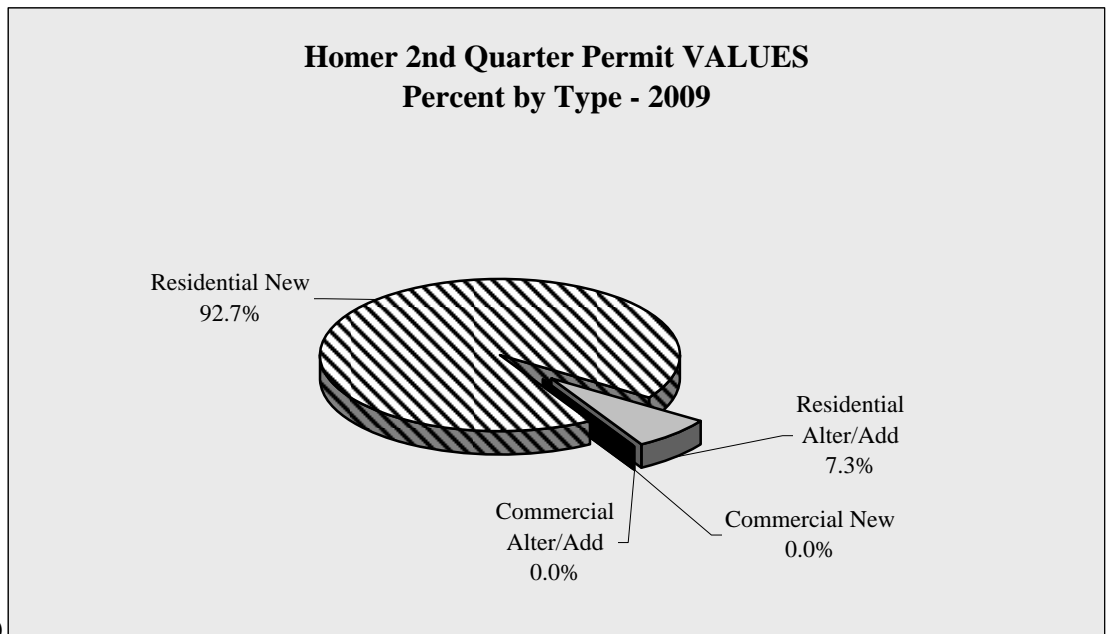

Chart 2.20

Homer Construction

Homer 2nd Quarter Permit VOLUME by Type - 2003-2009

	2003	2004	2005	2006	2007	2008	2009	Annual Change
Residential New	17	15	22	23	23	24	12	-50.0%
Residential Alter/Add	6	5	13	8	8	5	7	40.0%
Commercial New	7	5	10	5	9	2	0	-100.0%
Commercial Alter/Add	4	1	2	3	1	0	0	0.0%
Total	34	26	47	39	41	31	19	-38.7%
Annual Change		-23.5%	80.8%	-17.0%	5.1%	-24.4%	-38.7%	

Table 2.29

Homer 2nd Quarter Permit VOLUME by Type - 1986-2009

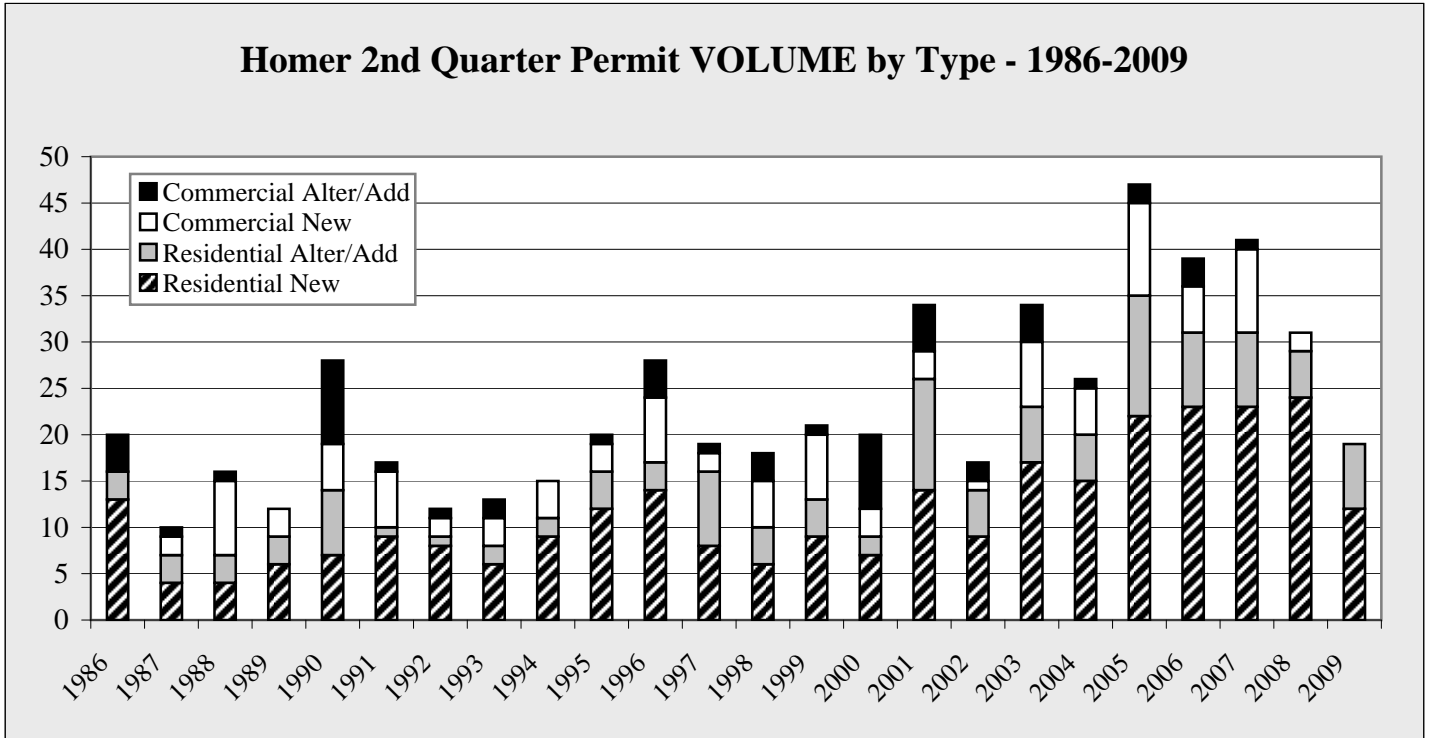

Chart 2.21

**Homer 2nd Quarter Permit VOLUME
Percent by Type - 2009**

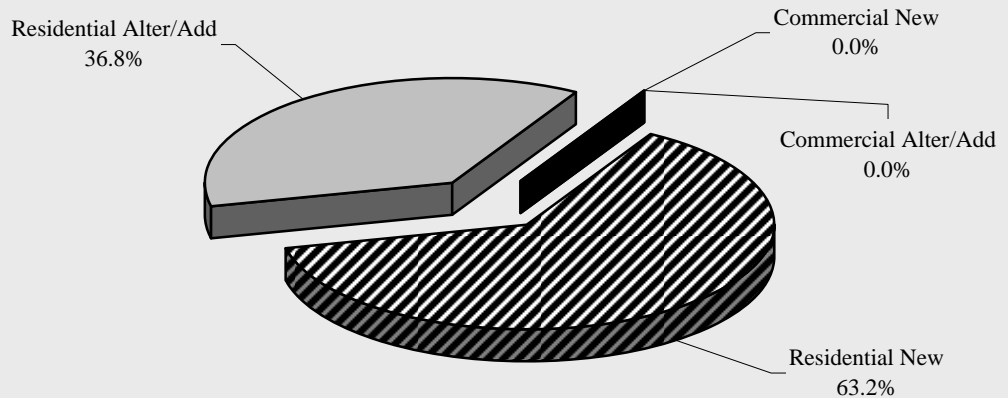

Chart 2.22

Homer Construction

Homer YTD 6/30 Permit VALUES by Type - 2003-2009 - in \$								
	2003	2004	2005	2006	2007	2008	2009	Annual Change
Residential New	4,791,280	5,092,900	4,766,400	5,895,100	4,760,000	6,488,000	2,645,000	-59.2%
Residential Alter/Add	471,600	407,250	452,500	287,000	482,000	163,000	255,500	56.7%
Commercial New	3,535,720	5,615,518	7,581,000	2,936,000	2,095,001	10,000,000	600,000	-94.0%
Commercial Alter/Add	465,240	32,063	1,552,000	1,620,000	20,000	0	0	0.0%
Total	9,263,840	11,147,731	14,351,900	10,738,100	7,357,001	16,651,000	3,500,500	-79.0%
Annual Change		20.3%	28.7%	-25.2%	-31.5%	126.3%	-79.0%	

Table 2.30

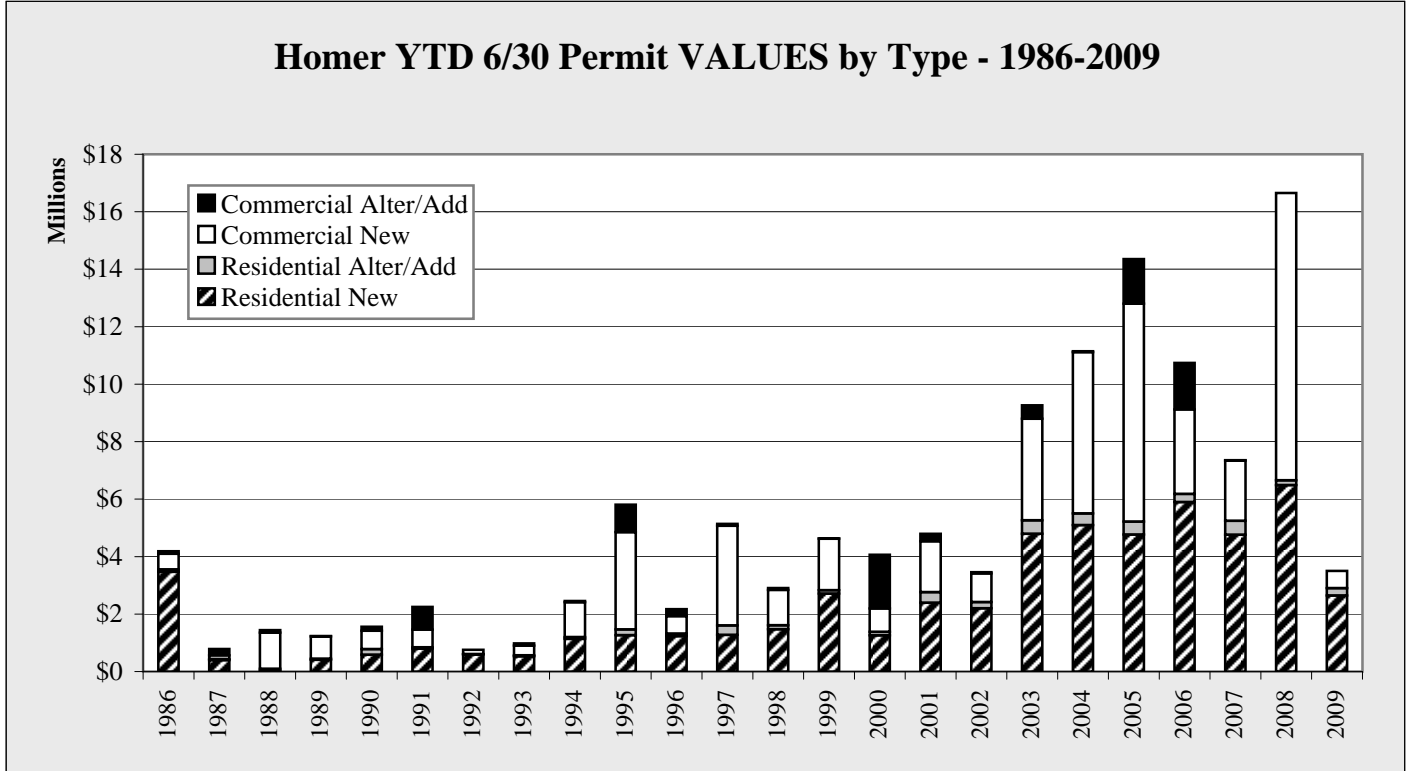

Chart 2.23

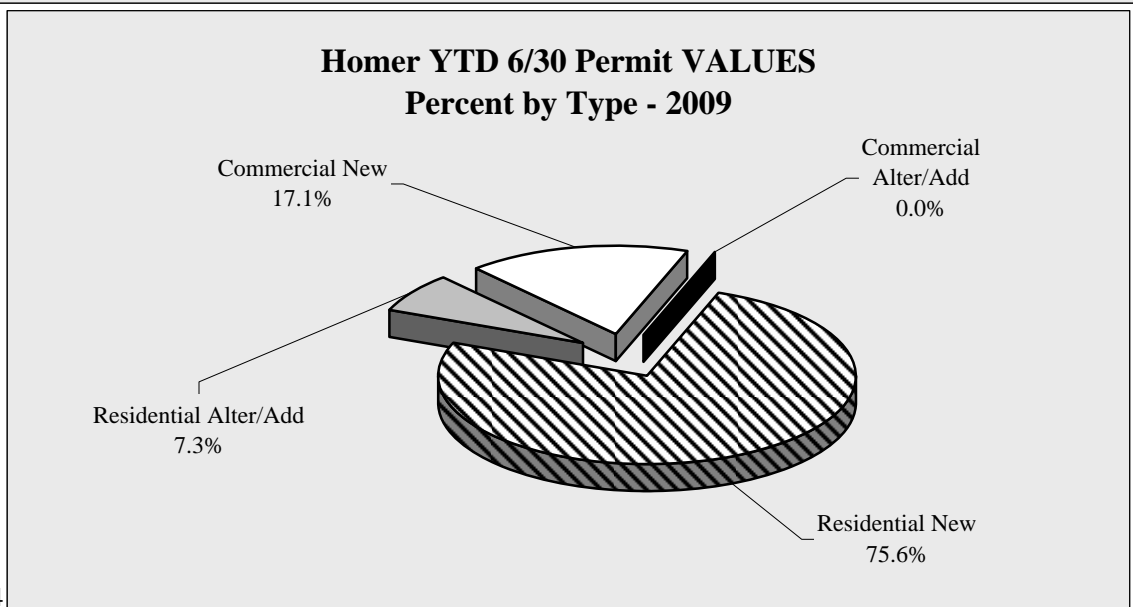

Chart 2.24

Homer Construction

Homer YTD 6/30 Permit VOLUME by Type - 2003-2009

	2003	2004	2005	2006	2007	2008	2009	Annual Change
Residential New	23	26	32	32	23	29	14	-51.7%
Residential Alter/Add	14	7	14	8	8	7	8	14.3%
Commercial New	7	7	12	9	9	2	1	-50.0%
Commercial Alter/Add	8	2	7	4	1	0	0	0.0%
Total	52	42	65	53	41	38	23	-39.5%
Annual Change		-19.2%	54.8%	-18.5%	-22.6%	-7.3%	-39.5%	

Table 2.31

Homer YTD 6/30 Permit VOLUME by Type - 1986-2009

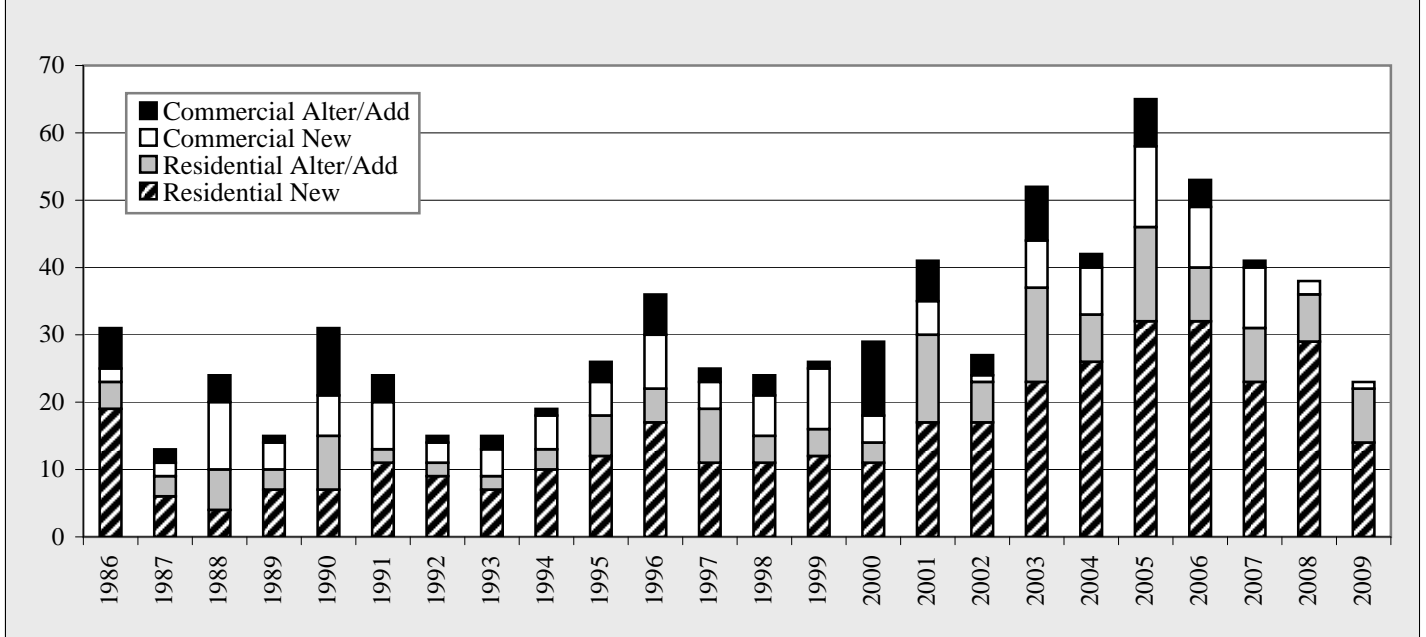

Chart 2.25

**Homer YTD 6/30 Permit VOLUME
Percent by Type - 2009**

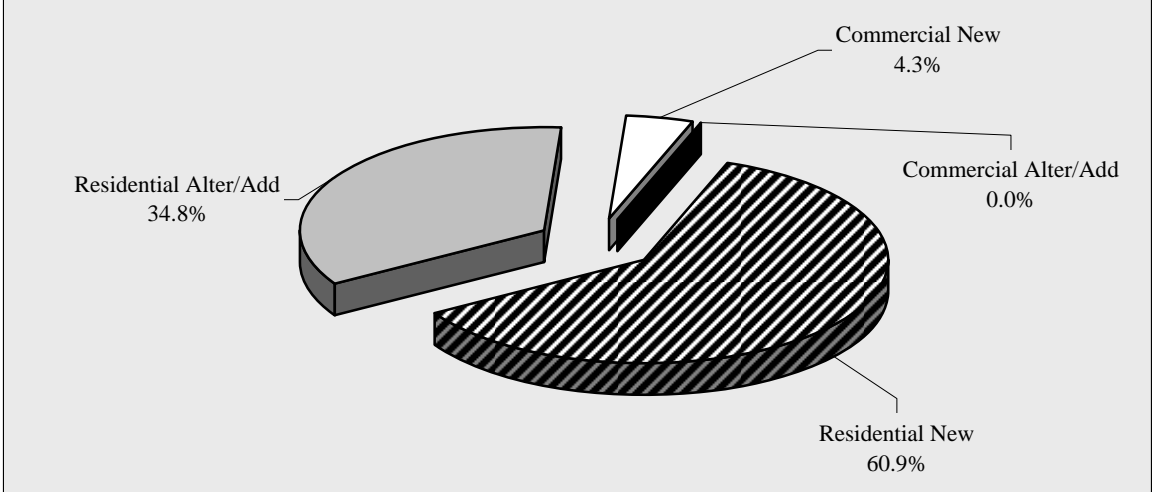

Chart 2.26

Homer Construction

Homer Annual Permit VALUES by Type by Quarter - 2002-2009 - in \$					
	1st Quarter	2nd Quarter	3rd Quarter	4th Quarter	Annual Total
2002					
Residential - New	891,760	1,308,460	1,466,300	560,200	4,226,720
Residential - Add/Alter	8,960	205,400	217,940	104,320	536,620
Commercial - New	0	1,000,000	3,912,740	78,000	4,990,740
Commercial - Add/Alter	28,000	14,349	180,350	72,000	294,699
TOTAL	928,720	2,528,209	5,777,330	814,520	10,048,779
2003					
Residential - New	979,800	3,811,480	2,106,275	1,222,900	8,120,455
Residential - Add/Alter	232,540	239,060	285,000	50,000	806,600
Commercial - New	0	3,535,720	628,800	1,600,000	5,764,520
Commercial - Add/Alter	122,000	343,240	0	170,000	635,240
TOTAL	1,334,340	7,929,500	3,020,075	3,042,900	15,326,815
2004					
Residential - New	2,597,500	2,495,400	1,225,600	377,000	6,695,500
Residential - Add/Alter	201,520	205,730	851,300	437,000	1,695,550
Commercial - New	915,000	4,700,518	6,225,000	2,560,000	14,400,518
Commercial - Add/Alter	0	32,063	1,230,000	17,000	1,279,063
TOTAL	3,714,020	7,433,711	9,531,900	3,391,000	24,070,631
2005					
Residential - New	1,694,400	3,072,000	1,548,500	895,000	7,209,900
Residential - Add/Alter	1,500	451,000	374,000	80,000	906,500
Commercial - New	108,000	7,473,000	2,240,000	1,975,000	11,796,000
Commercial - Add/Alter	1,302,000	250,000	120,000	27,000	1,699,000
TOTAL	3,105,900	11,246,000	4,282,500	2,977,000	21,611,400
2006					
Residential - New	1,645,000	4,250,100	3,610,700	550,000	10,055,800
Residential - Add/Alter	0	287,000	249,057	5,000	541,057
Commercial - New	626,000	2,310,000	3,135,000	2,000,000	8,071,000
Commercial - Add/Alter	1,000,000	620,000	0	0	1,620,000
TOTAL	3,271,000	7,467,100	6,994,757	2,555,000	20,287,857
2007					
Residential - New	55,000	4,705,000	2,045,100	845,000	7,650,100
Residential - Add/Alter	0	482,000	674,500	476,000	1,632,500
Commercial - New	0	2,085,001	2,321,600	301,000	4,707,601
Commercial - Add/Alter	1	20,000	46,000	0	66,001
TOTAL	55,001	7,292,001	5,087,200	1,622,000	14,056,202
2008					
Residential - New	1,195,000	6,488,000	1,553,200	890,000	10,126,200
Residential - Add/Alter	28,000	163,000	193,000	610,000	994,000
Commercial - New	1,500,000	10,000,000	0	560,000	12,060,000
Commercial - Add/Alter	0	0	664,000	824,000	1,488,000
TOTAL	2,723,000	16,651,000	2,410,200	2,884,000	24,668,200
2009 YTD					
Residential - New	430,000	2,215,000			2,645,000
Residential - Add/Alter	80,000	175,500			255,500
Commercial - New	600,000	0			600,000
Commercial - Add/Alter	0	0			0
TOTAL	1,110,000	2,390,500	0	0	3,500,500

Table 2.32

Homer Construction

Homer Annual Permit VOLUME by Type by Quarter - 2002-2009					
	1st Quarter	2nd Quarter	3rd Quarter	4th Quarter	Annual Total
2002					
Residential - New	8	9	10	5	32
Residential - Add/Alter	1	5	8	6	20
Commercial - New	0	1	6	1	8
Commercial - Add/Alter	1	2	3	1	7
TOTAL	10	17	27	13	67
2003					
Residential - New	6	17	15	9	47
Residential - Add/Alter	8	6	3	2	19
Commercial - New	0	7	3	1	11
Commercial - Add/Alter	4	4	0	1	9
TOTAL	18	34	21	13	86
2004					
Residential - New	11	15	9	6	41
Residential - Add/Alter	2	5	21	9	37
Commercial - New	2	5	8	7	22
Commercial - Add/Alter	1	1	4	2	8
TOTAL	16	26	42	24	108
2005					
Residential - New	10	22	13	6	51
Residential - Add/Alter	1	13	9	2	25
Commercial - New	2	10	4	2	18
Commercial - Add/Alter	5	2	1	1	9
TOTAL	18	47	27	11	103
2006					
Residential - New	9	23	15	2	49
Residential - Add/Alter	0	8	7	1	16
Commercial - New	4	5	3	2	14
Commercial - Add/Alter	1	3	0	0	4
TOTAL	14	39	25	5	83
2007					
Residential - New	2	22	12	5	41
Residential - Add/Alter	0	8	12	8	28
Commercial - New	1	9	3	3	16
Commercial - Add/Alter	0	1	1	0	2
TOTAL	3	40	28	16	87
2008					
Residential - New	5	24	4	5	38
Residential - Add/Alter	2	5	7	4	18
Commercial - New	0	2	0	1	3
Commercial - Add/Alter	0	0	2	1	3
TOTAL	7	31	13	11	62
2009					Year to Date
Residential - New	2	12			14
Residential - Add/Alter	1	7			8
Commercial - New	1	0			1
Commercial - Add/Alter	0	0			0
TOTAL	4	19	0	0	23

Table 2.33

KENAI

Kenai Sales

Kenai Second Quarter GROSS Sales by Line of Business - 2004-2009 - in \$								
LOB	2004	2005	2006	2007	2008	2009	Annual Percent Change	Annual Amount Change
PROD	1,445,143	580,847	1,728,194	2,564,489	7,935,421	3,197,453	-59.7%	-4,737,968
SALES	28,062,894	28,214,824	36,731,837	31,091,425	33,718,890	40,864,418	21.2%	7,145,528
CONST	2,765,328	6,899,419	5,493,041	7,349,364	14,056,938	17,407,285	23.8%	3,350,347
PROP	3,987,056	3,889,087	4,399,970	4,128,214	4,420,459	4,658,488	5.4%	238,029
TOUR	3,812,697	4,028,488	4,692,008	4,476,354	2,270,197	1,788,806	-21.2%	-481,391
SERV	5,300,763	5,137,398	5,178,499	6,524,215	6,183,799	6,128,467	-0.9%	-55,332
PROF	2,962,456	3,087,948	3,715,180	3,398,315	3,421,193	3,523,925	3.0%	102,732
UTIL	2,014,506	2,424,732	2,886,141	3,263,725	3,438,931	4,328,046	25.9%	889,115
MANU	4,614,353	4,701,193	5,782,515	5,843,067	6,451,944	7,010,110	8.7%	558,166
TRAN	7,578,207	24,047,836	22,621,496	24,593,825	39,669,786	3,774,222	-90.5%	-35,895,564
WHLS	17,244,557	18,746,329	15,264,810	17,741,429	24,108,292	11,444,482	-52.5%	-12,663,810
GOV	600,129	689,895	795,527	998,930	904,613	899,470	-0.6%	-5,143
TOTAL	80,388,089	102,447,996	109,289,218	111,973,352	146,580,463	105,025,172	-28.3%	-41,555,291

Table 3.1 For complete listing of Lines of Business, see page 17

Kenai Second Quarter GROSS Sales History	
2004	80,388,089
2005	102,447,996
2006	109,289,218
2007	111,973,352
2008	146,580,463
2009	105,025,172

Table 3.2

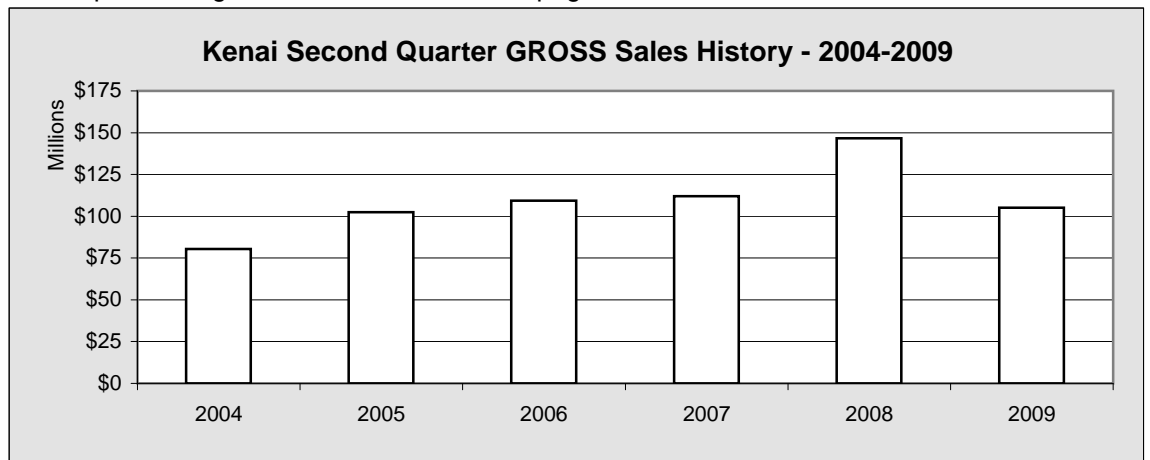

Chart 3.1

Kenai Five Year Change Second Quarter GROSS Sales		
LOB	2004	2009
PROD	1,445,143	3,197,453
SALES	28,062,894	40,864,418
CONST	2,765,328	17,407,285
PROP	3,987,056	4,658,488
TOUR	3,812,697	1,788,806
SERV	5,300,763	6,128,467
PROF	2,962,456	3,523,925
UTIL	2,014,506	4,328,046
MANU	4,614,353	7,010,110
TRAN	7,578,207	3,774,222
WHLS	17,244,557	11,444,482
GOV	600,129	899,470
TOTAL	80,388,089	105,025,172

Table 3.3

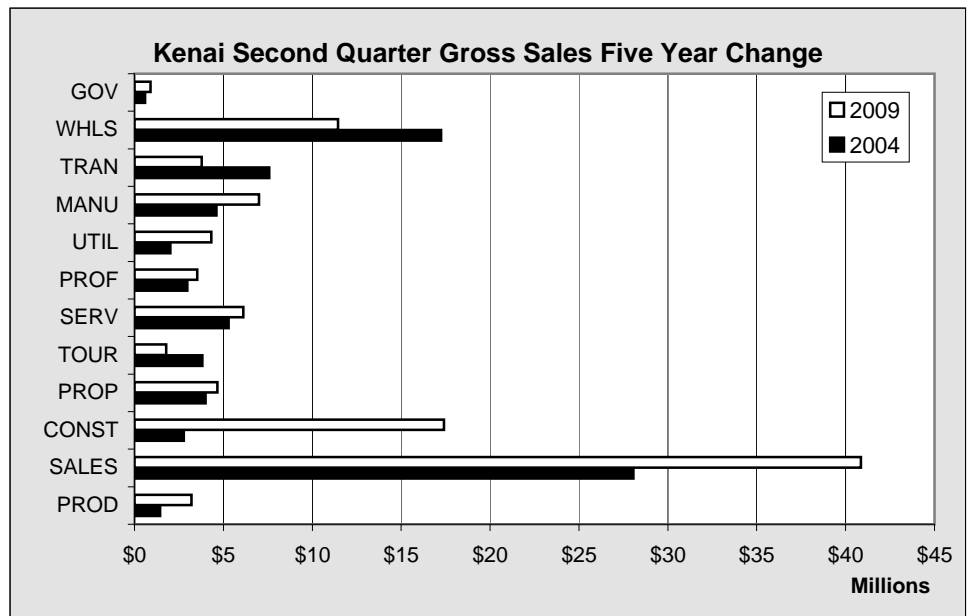

Chart 3.2

Kenai Sales

Kenai Second Quarter TAXABLE Sales by Line of Business - 2004-2009 - in \$								
LOB	2004	2005	2006	2007	2008	2009	Annual Percent Change	Annual Amount Change
PROD	186,958	173,152	172,765	204,307	200,916	156,600	-22.1%	-44,316
SALES	16,085,847	17,192,039	18,954,781	19,981,833	23,754,686	26,329,457	10.8%	2,574,771
CONST	323,050	320,715	281,168	306,232	300,847	375,736	24.9%	74,889
PROP	1,899,560	1,809,235	1,944,306	2,035,552	2,083,451	2,464,127	18.3%	380,676
TOUR	3,620,678	3,750,124	4,490,982	4,273,621	2,040,331	1,650,820	-19.1%	-389,511
SERV	3,790,520	3,313,149	3,517,175	4,208,016	4,051,203	4,354,013	7.5%	302,810
PROF	798,222	792,805	844,222	802,580	951,266	823,847	-13.4%	-127,419
UTIL	1,315,964	1,469,845	1,749,039	2,035,875	2,014,942	2,429,660	20.6%	414,718
MANU	194,275	194,451	196,427	196,958	240,182	173,997	-27.6%	-66,185
TRAN	119,512	160,310	249,474	351,078	448,028	572,823	27.9%	124,795
WHLS	7,529,985	7,776,735	8,203,295	8,166,287	8,249,920	6,632,557	-19.6%	-1,617,363
GOV	399,217	450,679	503,795	546,299	524,436	540,745	3.1%	16,309
TOTAL	36,263,788	37,403,239	41,107,429	43,108,638	44,860,208	46,504,382	3.7%	1,644,174

Table 3.4 For complete listing of Lines of Business, see page 17

Kenai Second Quarter TAXABLE Sales History	
2004	36,263,788
2005	37,403,239
2006	41,107,429
2007	43,108,638
2008	44,860,208
2009	46,504,382

Table 3.5

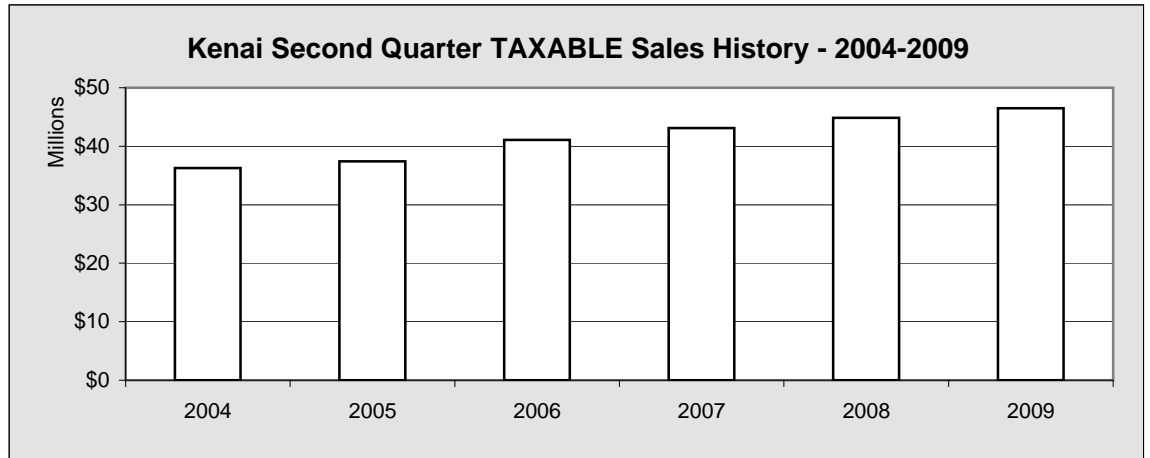

Chart 3.3

Kenai Five Year Change Second Quarter TAXABLE Sales		
LOB	2004	2009
PROD	186,958	156,600
SALES	16,085,847	26,329,457
CONST	323,050	375,736
PROP	1,899,560	2,464,127
TOUR	3,620,678	1,650,820
SERV	3,790,520	4,354,013
PROF	798,222	823,847
UTIL	1,315,964	2,429,660
MANU	194,275	173,997
TRAN	119,512	572,823
WHLS	7,529,985	6,632,557
GOV	399,217	540,745
TOTAL	36,263,788	46,504,382

Table 3.6

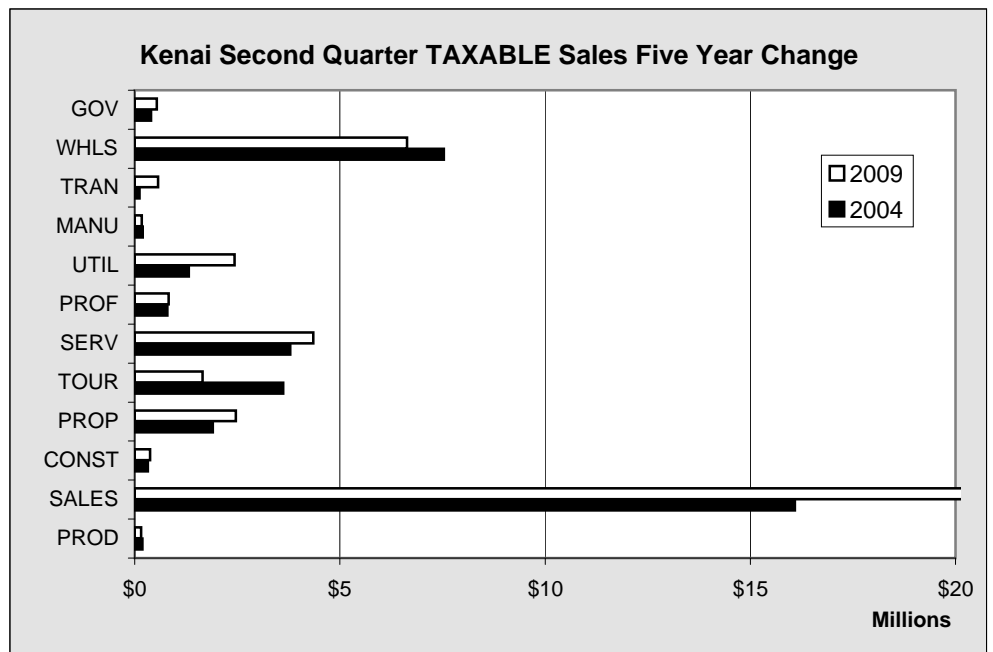

Chart 3.4

Kenai Sales

Kenai YTD June 30 GROSS Sales by Line of Business - 2004-2009 - in \$

LOB	2004	2005	2006	2007	2008	2009	Annual Percent Change	Annual Amount Change
PROD	2,492,676	2,097,983	2,825,557	3,229,310	6,141,694	10,747,052	75.0%	4,605,358
SALES	50,812,943	51,613,889	62,617,016	56,553,862	26,219,739	68,951,001	163.0%	42,731,262
CONST	5,051,597	8,963,654	7,181,194	11,930,387	3,751,629	21,296,290	467.7%	17,544,661
PROP	7,517,409	7,324,084	7,985,132	7,851,649	4,048,849	9,056,150	123.7%	5,007,301
TOUR	6,718,773	6,867,057	7,926,824	7,647,373	2,955,035	2,748,809	-7.0%	-206,226
SERV	9,855,050	9,560,749	10,067,763	11,895,708	5,539,958	11,579,340	109.0%	6,039,382
PROF	6,265,803	7,313,066	7,542,056	7,471,261	3,325,366	6,086,466	83.0%	2,761,100
UTIL	4,756,309	5,921,504	6,826,648	7,845,511	3,524,218	10,909,862	209.6%	7,385,644
MANU	7,755,524	7,631,801	8,306,279	10,390,671	5,375,390	9,990,004	85.8%	4,614,614
TRAN	9,138,568	38,879,201	25,334,953	55,210,671	30,644,258	7,172,805	-76.6%	-23,471,453
WHLS	29,900,816	30,502,648	24,434,621	26,815,873	15,591,985	20,747,687	33.1%	5,155,702
GOV	1,205,625	1,331,700	1,525,315	1,790,194	834,505	1,733,227	107.7%	898,722
TOTAL	141,471,093	178,007,336	172,573,358	208,632,470	107,952,626	181,018,693	67.7%	73,066,067

Table 3.7

For complete listing of Lines of Business, see page 17

Kenai YTD June 30 GROSS Sales History	
2004	141,471,093
2005	178,007,336
2006	172,573,358
2007	208,632,470
2008	107,952,626
2009	181,018,693

Table 3.8

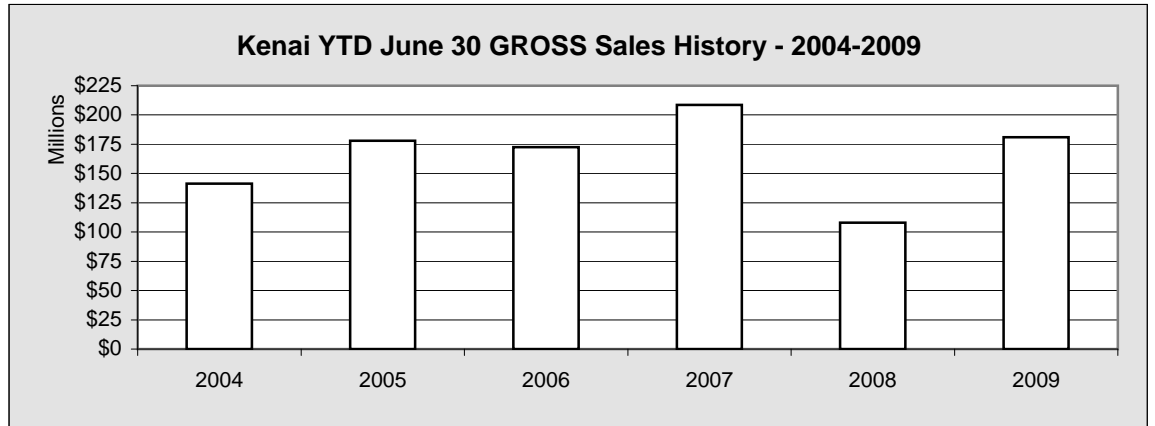

Chart 3.5

Kenai Five Year Change YTD June 30 GROSS Sales		
	2004	2009
PROD	2,492,676	10,747,052
SALES	50,812,943	68,951,001
CONST	5,051,597	21,296,290
PROP	7,517,409	9,056,150
TOUR	6,718,773	2,748,809
SERV	9,855,050	11,579,340
PROF	6,265,803	6,086,466
UTIL	4,756,309	10,909,862
MANU	7,755,524	9,990,004
TRAN	9,138,568	7,172,805
WHLS	29,900,816	20,747,687
GOV	1,205,625	1,733,227
TOTAL	141,471,093	181,018,693

Table 3.9

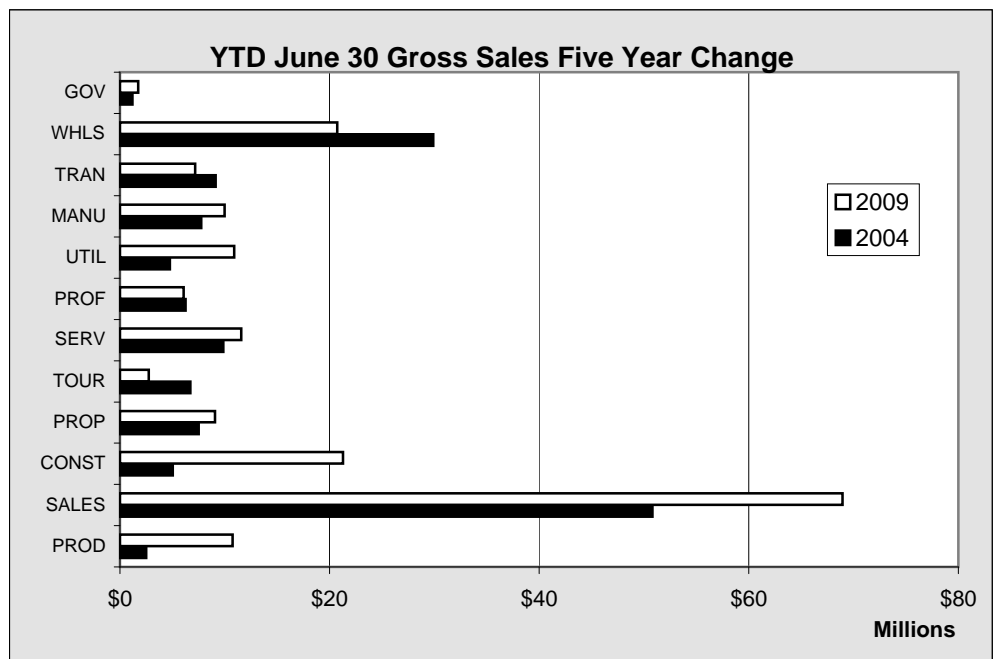

Chart 3.6

Kenai Sales

Kenai YTD June 30 TAXABLE Sales by Line of Business - 2004-2009 - in \$								
LOB	2004	2005	2006	2007	2008	2009	Annual Percent Change	Annual Amount Change
PROD	280,039	248,662	231,519	261,876	89,203	216,774	143.0%	127,571
SALES	29,431,342	31,141,710	34,081,644	36,442,661	18,479,128	47,506,234	157.1%	29,027,106
CONST	614,576	541,022	517,463	571,764	249,430	644,457	158.4%	395,027
PROP	3,650,326	3,547,266	3,694,906	3,926,709	1,934,696	4,505,905	132.9%	2,571,209
TOUR	6,391,814	6,435,169	7,550,523	7,309,105	2,866,244	2,521,482	-12.0%	-344,762
SERV	7,198,192	6,407,722	6,948,191	7,860,583	3,732,983	8,193,942	119.5%	4,460,959
PROF	1,667,803	1,669,764	1,716,396	1,705,678	889,583	1,743,031	95.9%	853,448
UTIL	3,155,863	3,506,053	4,152,418	4,915,588	1,964,811	6,112,991	211.1%	4,148,180
MANU	347,438	290,923	308,424	318,243	116,048	296,817	155.8%	180,769
TRAN	200,409	231,519	394,714	476,117	236,082	948,403	301.7%	712,321
WHLS	12,100,344	12,023,716	12,940,445	12,589,011	4,239,093	10,153,377	139.5%	5,914,284
GOV	782,133	864,625	971,501	1,041,596	480,784	1,018,844	111.9%	538,060
TOTAL	65,820,279	66,908,151	73,508,144	77,418,931	35,278,085	83,862,290	137.7%	48,584,205

Table 3.10

For complete listing of Lines of Business, see page 17

Kenai YTD June 30 TAXABLE Sales History	
2004	65,820,279
2005	66,908,151
2006	73,508,144
2007	77,418,931
2008	35,278,085
2009	83,862,290

Table 3.11

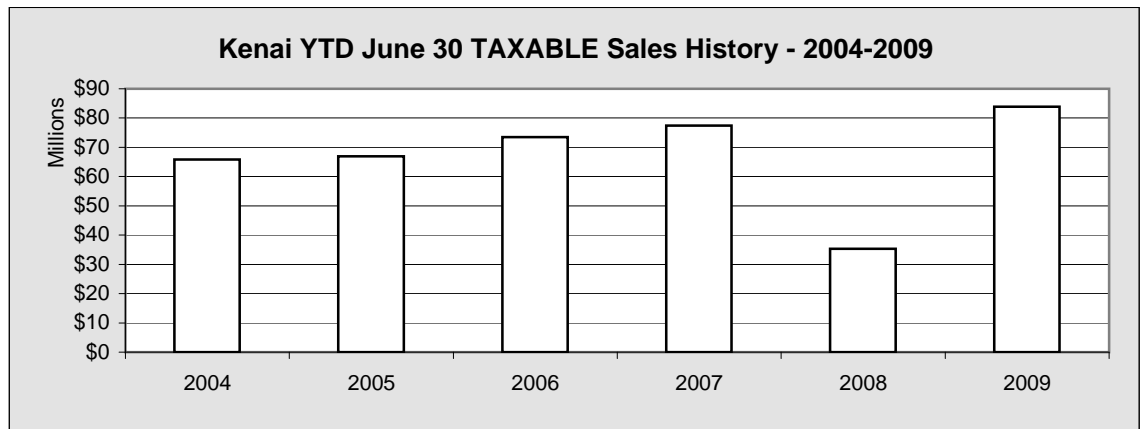

Chart 3.7

Kenai Five Year Change YTD June 30 TAXABLE Sales		
	2004	2009
PROD	280,039	216,774
SALES	29,431,342	47,506,234
CONST	614,576	644,457
PROP	3,650,326	4,505,905
TOUR	6,391,814	2,521,482
SERV	7,198,192	8,193,942
PROF	1,667,803	1,743,031
UTIL	3,155,863	6,112,991
MANU	347,438	296,817
TRAN	200,409	948,403
WHLS	12,100,344	10,153,377
GOV	782,133	1,018,844
TOTAL	65,820,279	83,862,290

Table 3.12

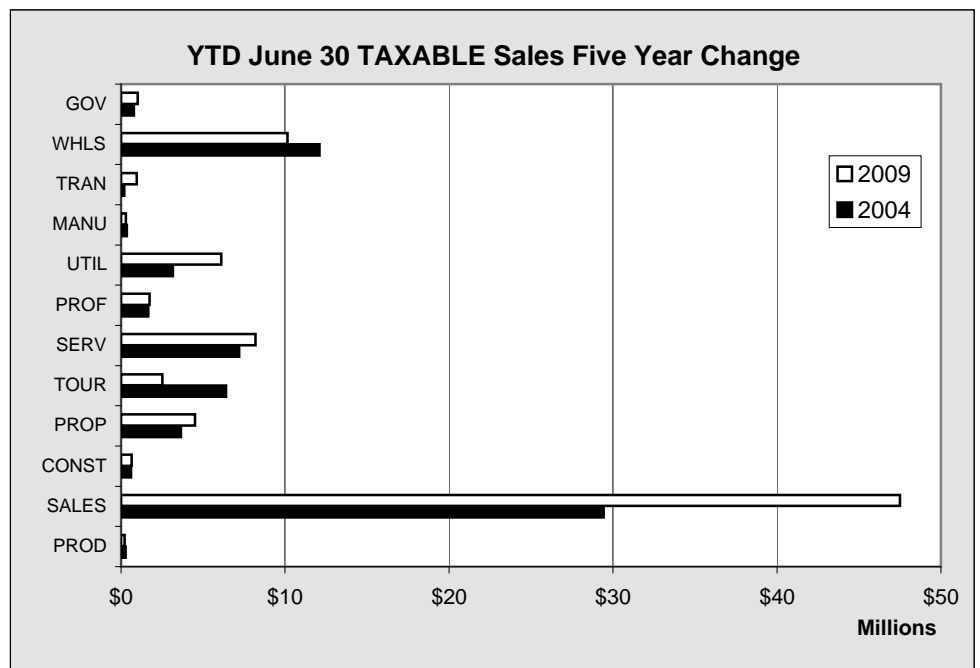

Chart 3.8

Kenai Sales

Kenai Annual GROSS Sales by Line of Business - 2003-2008 - in \$								
LOB	2003	2004	2005	2006	2007	2008	Annual Percent Change	Annual Amount Change
PROD	4,726,857	100,022,855	78,876,010	43,287,832	46,716,466	60,540,134	29.6%	13,823,668
SALES	107,530,358	108,645,907	112,006,670	124,143,661	122,592,351	139,749,141	14.0%	17,156,790
CONST	30,539,441	13,129,482	25,430,918	40,880,928	34,010,065	55,208,519	62.3%	21,198,454
PROP	17,965,712	16,264,986	18,417,832	17,517,133	17,150,510	19,141,133	11.6%	1,990,623
TOUR	14,870,397	15,956,285	16,544,762	18,720,706	18,181,009	8,760,422	-51.8%	-9,420,587
SERV	20,745,270	19,839,374	19,907,748	22,170,304	25,694,573	25,060,324	-2.5%	-634,249
PROF	13,830,788	13,816,386	14,633,670	15,910,045	15,306,314	13,541,236	-11.5%	-1,765,078
UTIL	8,965,563	9,370,432	13,871,188	13,006,437	14,199,488	15,448,408	8.8%	1,248,920
MANU	26,455,314	26,232,173	33,428,325	29,206,480	32,688,259	38,110,739	16.6%	5,422,480
TRAN	4,625,552	17,553,410	66,585,592	74,705,995	119,611,694	150,485,791	25.8%	30,874,097
WHLS	29,926,647	63,578,072	62,846,060	53,888,047	70,341,832	77,529,329	10.2%	7,187,497
GOV	2,700,596	2,862,813	3,231,177	3,494,476	4,064,513	4,101,380	0.9%	36,867
TOTAL	282,882,495	407,272,175	465,779,952	456,932,044	520,557,074	607,676,556	16.7%	87,119,482

Table 3.13

For complete listing of Lines of Business, see page 17

Kenai Annual GROSS Sales History	
2003	282,882,495
2004	407,272,175
2005	465,779,952
2006	456,932,044
2007	520,557,074
2008	607,676,556

Table 3.14

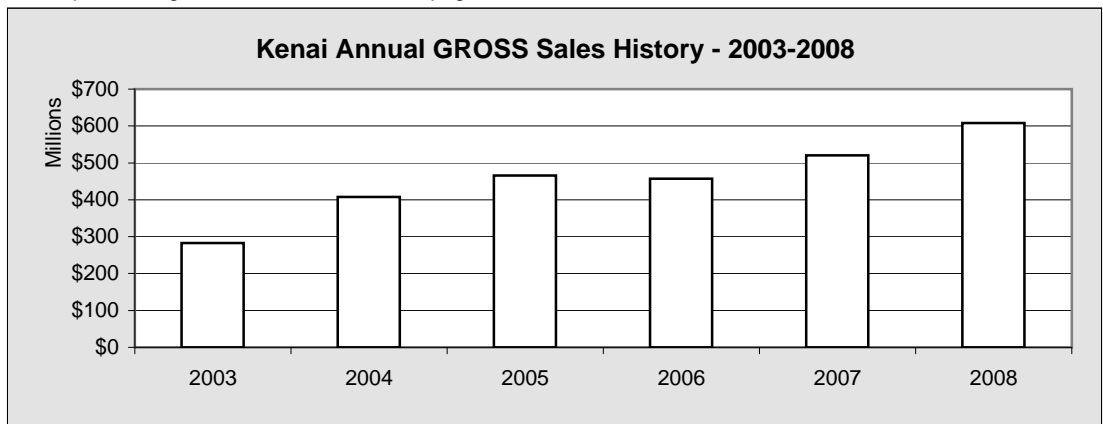

Chart 3.9

Five Year Change Annual GROSS Sales		
LOB	2003	2008
PROD	4,726,857	60,540,134
SALES	107,530,358	139,749,141
CONST	30,539,441	55,208,519
PROP	17,965,712	19,141,133
TOUR	14,870,397	8,760,422
SERV	20,745,270	25,060,324
PROF	13,830,788	13,541,236
UTIL	8,965,563	15,448,408
MANU	26,455,314	38,110,739
TRAN	4,625,552	150,485,791
WHLS	29,926,647	77,529,329
GOV	2,700,596	4,101,380
TOTAL	282,882,495	607,676,556

Table 3.15

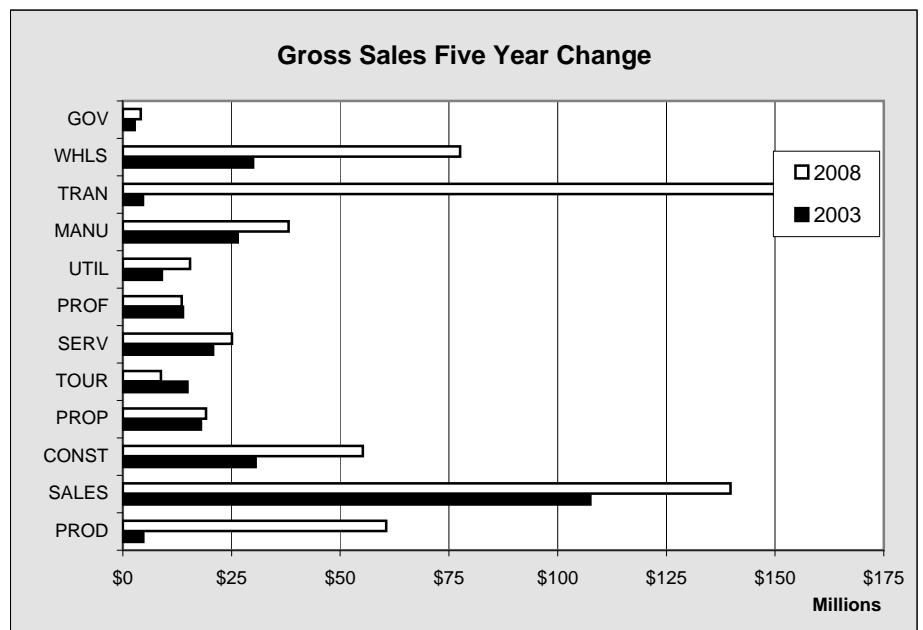

Chart 3.10

Kenai Sales

Kenai Annual TAXABLE Sales by Line of Business - 2003-2008 - in \$								
LOB	2003	2004	2005	2006	2007	2008	Annual Percent Change	Annual Amount Change
PROD	488,890	494,772	467,755	440,218	520,505	520,028	-0.1%	-477
SALES	64,294,562	63,884,387	68,365,098	73,008,240	79,962,518	96,483,648	20.7%	16,521,130
CONST	1,233,344	1,200,427	1,119,137	1,188,349	1,265,859	1,294,990	2.3%	29,131
PROP	8,015,439	7,996,496	7,960,746	8,116,133	8,591,878	9,560,366	11.3%	968,488
TOUR	13,961,938	14,416,689	14,833,825	17,163,429	16,851,017	7,872,506	-53.3%	-8,978,511
SERV	15,434,023	13,740,498	12,853,366	13,875,894	15,927,982	16,054,477	0.8%	126,495
PROF	3,090,294	3,418,239	3,399,151	3,478,120	3,288,890	3,607,232	9.7%	318,342
UTIL	5,509,627	5,765,278	6,386,909	7,605,058	8,465,960	8,906,132	5.2%	440,172
MANU	893,384	1,057,618	1,140,898	883,767	1,061,647	939,292	-11.5%	-122,355
TRAN	318,401	239,198	346,647	670,327	962,740	1,665,116	73.0%	702,376
WHLS	6,336,422	25,239,822	26,564,628	28,050,311	27,805,502	26,632,258	-4.2%	-1,173,244
GOV	1,738,471	1,920,438	2,097,894	2,160,749	2,372,880	833,757	-64.9%	-1,539,123
TOTAL	121,314,795	139,373,862	145,536,054	156,640,595	167,077,378	174,369,802	4.4%	7,292,424

Table 3.16

For complete listing of Lines of Business, see page 17

Kenai Annual TAXABLE Sales History	
2003	121,314,795
2004	139,373,862
2005	145,536,054
2006	156,640,595
2007	167,077,378
2008	174,369,802

Table 3.17

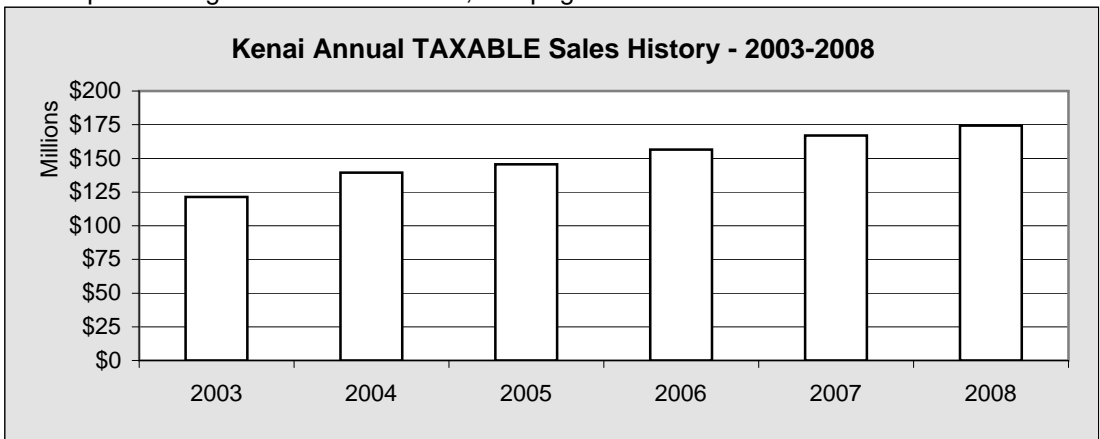

Chart 3.11

Five Year Change Annual TAXABLE Sales		
LOB	2003	2008
PROD	488,890	520,028
SALES	64,294,562	96,483,648
CONST	1,233,344	1,294,990
PROP	8,015,439	9,560,366
TOUR	13,961,938	7,872,506
SERV	15,434,023	16,054,477
PROF	3,090,294	3,607,232
UTIL	5,509,627	8,906,132
MANU	893,384	939,292
TRAN	318,401	1,665,116
WHLS	6,336,422	26,632,258
GOV	1,738,471	833,757
TOTAL	121,314,795	174,369,802

Table 3.18

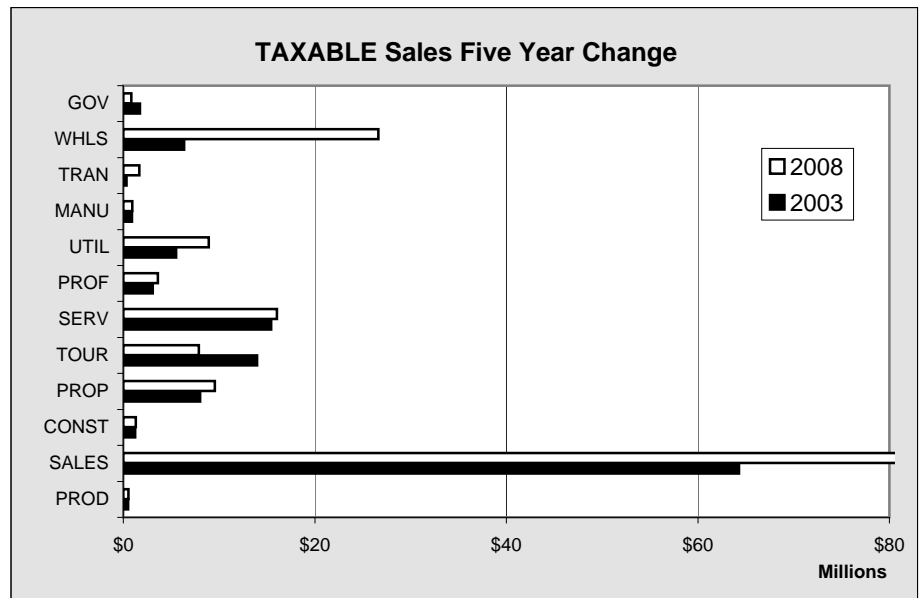

Chart 3.12

Kenai Sales

Kenai GROSS Sales by Line of Business by Quarter - 2008 - in \$

	1st Quarter	2nd Quarter	3rd Quarter	4th Quarter	Total
Resource Production	6,141,814	7,935,421	6,061,323	40,401,576	60,540,134
Sales	27,518,789	33,718,890	40,914,680	37,596,782	139,749,141
Construction	3,881,416	14,056,938	22,533,375	14,736,790	55,208,519
Property	4,084,772	4,420,459	5,521,248	5,114,654	19,141,133
Tourism	1,182,510	2,270,197	3,920,553	1,387,162	8,760,422
Services	5,484,844	6,183,799	7,177,639	6,214,042	25,060,324
Professional	3,532,617	3,421,193	3,123,406	3,464,020	13,541,236
Utility	4,537,381	3,438,931	3,055,902	4,416,194	15,448,408
Manufacturing	5,392,390	6,451,944	21,998,896	4,267,509	38,110,739
Transportation & Warehousing	30,629,052	39,669,786	43,707,193	36,479,760	150,485,791
Wholesale	15,591,985	24,108,292	23,001,404	14,827,648	77,529,329
Government	834,505	904,613	1,472,864	889,398	4,101,380
TOTAL	108,812,075	146,580,463	182,488,483	169,795,535	607,676,556

Table 3.19

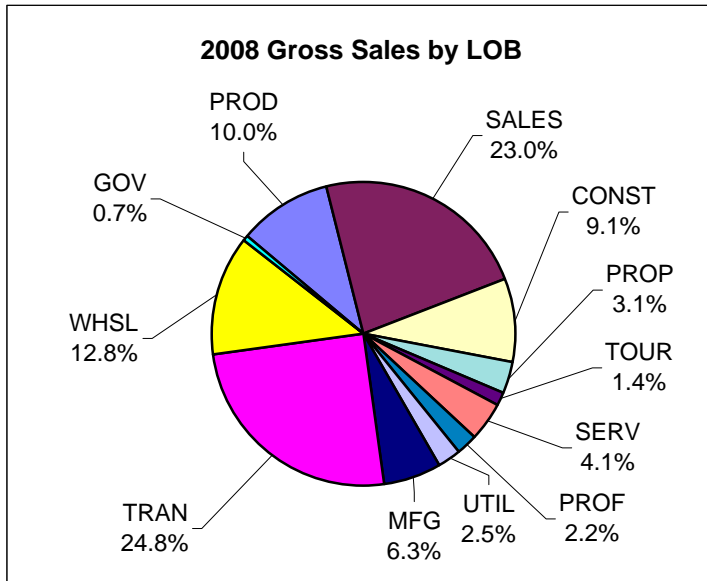

Chart 3.13

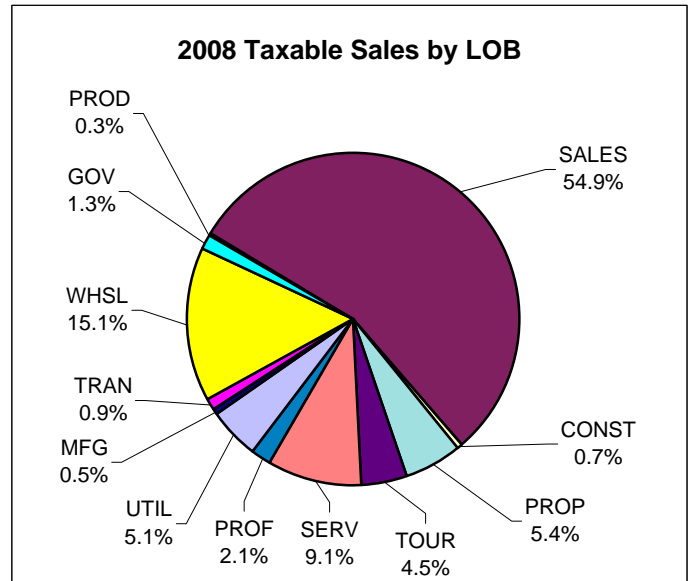

Chart 3.14

Kenai TAXABLE Sales by Line of Business by Quarter - 2007 - in \$

LOB	1st Quarter	2nd Quarter	3rd Quarter	4th Quarter	Total
Resource Production	89,323	200,916	112,719	117,070	520,028
Sales	20,157,525	23,754,686	28,026,000	24,545,437	96,483,648
Construction	269,117	300,847	369,364	355,662	1,294,990
Property	1,979,140	2,083,451	3,000,345	2,497,430	9,560,366
Tourism	1,080,836	2,040,331	3,475,076	1,276,263	7,872,506
Services	3,654,531	4,051,203	4,471,949	3,876,794	16,054,477
Professional	1,048,424	951,266	790,579	816,963	3,607,232
Utility	2,803,047	2,014,942	1,593,826	2,494,317	8,906,132
Manufacturing	133,048	240,182	408,508	157,554	939,292
Transportation & Warehousing	232,760	448,028	581,714	402,614	1,665,116
Wholesale	4,238,859	8,249,920	8,716,428	5,427,051	26,632,258
Government	512,784	524,436	827,495	490,724	2,355,439
TOTAL	36,199,394	44,860,208	52,374,003	42,457,879	175,891,484

Table 3.20

Kenai Sales

Kenai GROSS Sales by Line of Business by Quarter - 2007 - in \$					
LOB	1st Quarter	2nd Quarter	3rd Quarter	4th Quarter	Total
Resource Production	655,921	2,562,639	3,927,205	39,570,701	46,716,466
Sales	25,489,855	31,101,820	34,116,919	31,883,757	122,592,351
Construction	4,581,023	7,351,945	13,301,420	8,775,677	34,010,065
Property	3,728,842	4,129,632	4,495,337	4,796,699	17,150,510
Tourism	3,165,712	4,525,506	6,738,567	3,751,224	18,181,009
Services	5,385,333	6,525,505	7,027,991	6,755,744	25,694,573
Professional	4,072,946	3,398,315	3,711,731	4,123,322	15,306,314
Utility	4,581,786	3,263,725	2,891,115	3,462,862	14,199,488
Manufacturing	4,547,604	5,843,067	19,102,878	3,194,710	32,688,259
Transporation & Warehousing	30,603,635	24,517,859	33,364,286	31,125,914	119,611,694
Wholesale	9,074,444	17,741,429	22,917,023	20,608,936	70,341,832
Government	791,264	998,930	1,401,362	872,957	4,064,513
TOTAL	96,678,365	111,960,372	152,995,834	158,922,503	520,557,074

Table 3.21

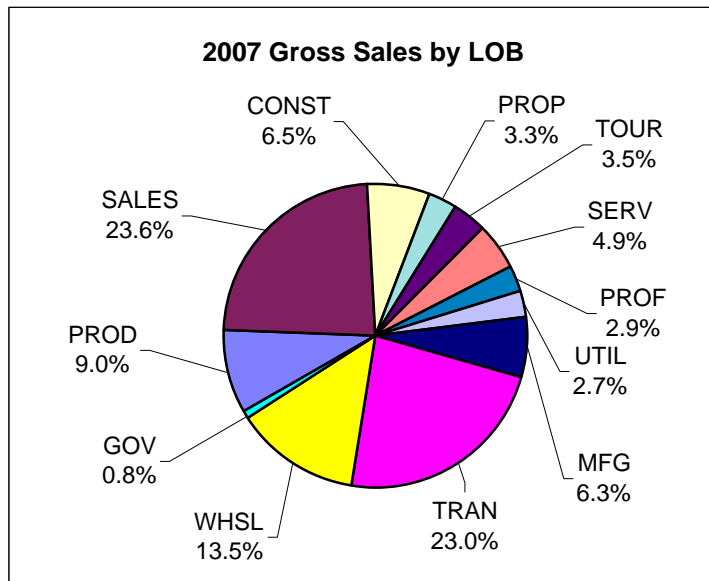

Chart 3.15

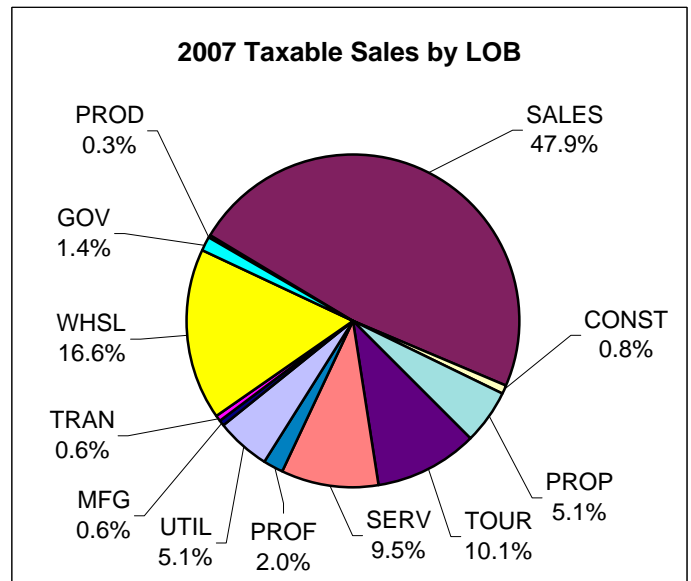

Chart 3.16

Kenai TAXABLE Sales by Line of Business by Quarter - 2007 - in \$					
LOB	1st Quarter	2nd Quarter	3rd Quarter	4th Quarter	Total
Resource Production	57,569	204,307	114,718	143,911	520,505
Sales	16,487,590	19,991,586	22,706,524	20,776,818	79,962,518
Construction	265,532	306,813	342,452	351,062	1,265,859
Property	1,947,916	2,094,540	2,298,849	2,250,573	8,591,878
Tourism	3,012,613	4,276,569	6,218,636	3,343,199	16,851,017
Services	3,510,801	4,084,453	4,379,319	3,953,409	15,927,982
Professional	991,605	871,047	722,766	703,472	3,288,890
Utility	2,879,713	2,035,875	1,498,109	2,052,263	8,465,960
Manufacturing	121,285	196,958	540,635	202,769	1,061,647
Transporation & Warehousing	121,148	322,108	289,404	230,080	962,740
Wholesale	4,422,724	8,166,287	8,633,646	6,582,845	27,805,502
Government	495,297	546,299	811,324	519,960	2,372,880
TOTAL	34,313,793	43,096,842	48,556,382	41,110,361	167,077,378

Table 3.22

Kenai Sales

Kenai GROSS Sales by Line of Business by Quarter - 2006 - in \$

LOB	1st Quarter	2nd Quarter	3rd Quarter	4th Quarter	Total
Resource Production	1,097,363	1,728,194	1,298,983	39,163,292	43,287,832
Sales	25,915,409	36,764,509	32,609,317	28,854,426	124,143,661
Construction	1,688,153	5,495,891	8,251,063	25,445,821	40,880,928
Property	3,574,662	4,389,470	5,000,463	4,552,538	17,517,133
Tourism	3,223,682	4,740,375	7,098,168	3,658,481	18,720,706
Services	4,889,784	5,182,062	5,941,675	6,156,783	22,170,304
Professional	3,827,587	3,715,180	4,331,435	4,035,843	15,910,045
Utility	3,940,507	2,886,141	2,448,211	3,731,578	13,006,437
Manufacturing	2,523,764	5,782,515	14,371,206	6,528,995	29,206,480
Transportation & Warehousing	2,693,130	22,534,044	22,978,804	26,500,017	74,705,995
Wholesale	9,169,811	15,264,810	16,125,342	13,328,084	53,888,047
Government	729,788	795,527	1,083,271	885,890	3,494,476
TOTAL	63,273,640	109,278,718	121,537,938	162,841,748	456,932,044

Table 3.23

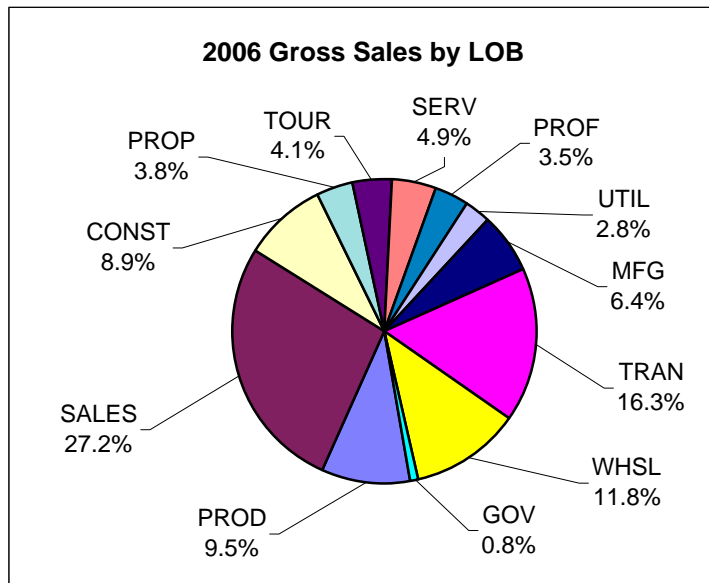

Chart 3.17

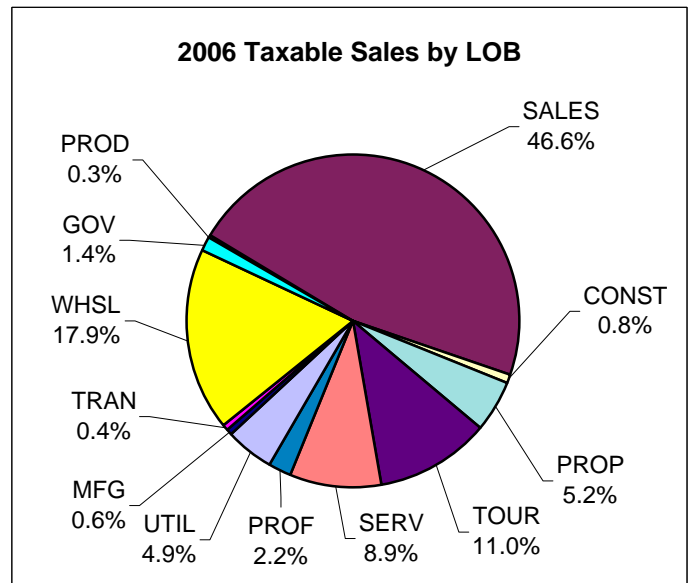

Chart 3.18

Kenai TAXABLE Sales by Line of Business by Quarter - 2006 - in \$

LOB	1st Quarter	2nd Quarter	3rd Quarter	4th Quarter	Total
Resource Production	58,754	172,765	89,798	118,901	440,218
Sales	15,154,575	18,982,552	20,482,972	18,388,141	73,008,240
Construction	236,295	283,398	314,112	354,544	1,188,349
Property	1,799,840	1,983,465	2,245,207	2,087,621	8,116,133
Tourism	3,041,808	4,504,591	6,147,138	3,469,892	17,163,429
Services	3,243,948	3,338,675	3,689,853	3,603,418	13,875,894
Professional	1,000,733	974,676	806,633	696,078	3,478,120
Utility	2,403,379	1,749,039	1,304,520	2,148,120	7,605,058
Manufacturing	111,997	196,427	420,755	154,588	883,767
Transportation & Warehousing	134,030	204,251	221,909	110,137	670,327
Wholesale	4,737,150	8,203,295	8,793,332	6,316,534	28,050,311
Government	467,706	503,795	700,435	488,813	2,160,749
TOTAL	32,390,215	41,096,929	45,216,664	37,936,787	156,640,595

Table 3.24

Kenai Sales

Kenai Annual Gross Sales by Quarter - in \$						
	1st Quarter	2nd Quarter	3rd Quarter	4th Quarter	Total	Annual Change
1994	57,188,988	59,340,975	76,208,889	56,477,738	249,216,590	
1995	47,025,594	63,188,380	103,891,510	53,966,235	268,071,719	7.6%
1996	44,272,558	59,006,953	89,244,719	56,206,797	248,731,027	-7.2%
1997	46,734,219	69,543,282	92,318,998	69,499,878	278,096,377	11.8%
1998	59,398,212	69,795,945	85,276,693	67,609,090	282,079,940	1.4%
1999	49,309,897	61,601,436	91,868,389	67,946,601	270,726,323	-4.0%
2000	55,609,576	66,148,908	89,482,163	72,403,855	283,644,502	4.8%
2001	62,412,055	76,653,184	94,911,501	76,422,702	310,399,442	9.4%
2002	60,485,936	67,818,581	82,467,626	68,523,671	279,295,814	-10.0%
2003	62,037,733	67,206,051	81,150,318	72,488,393	282,882,495	1.3%
2004	61,072,504	80,377,589	97,860,387	167,961,695	407,272,175	44.0%
2005	75,641,521	102,543,222	112,340,508	175,254,701	465,779,952	14.4%
2006	63,273,640	109,278,718	121,537,938	162,841,748	456,932,044	-1.9%
2007	96,678,365	111,960,372	152,995,834	158,922,503	520,557,074	13.9%
2008	108,812,075	146,580,463	182,488,483	169,795,535	607,676,556	16.7%
2009	79,993,521	105,025,172			185,018,693	
Change	-26.5%	-28.3%				

Table 3.25

Kenai Annual Taxable Sales by Quarter - in \$						
	1st Quarter	2nd Quarter	3rd Quarter	4th Quarter	Total	Annual Change
1994	24,600,688	28,256,972	32,750,392	28,793,983	114,402,035	
1995	22,806,366	28,328,016	32,447,853	28,983,412	112,565,647	-1.6%
1996	23,821,757	29,825,649	33,254,658	29,649,466	116,551,530	3.5%
1997	23,734,621	30,223,772	34,152,494	30,465,867	118,576,754	1.7%
1998	24,686,791	30,026,162	33,360,588	31,957,166	120,030,707	1.2%
1999	25,183,897	30,901,457	34,547,855	33,714,087	124,347,296	3.6%
2000	25,521,513	31,538,250	36,610,960	34,057,441	127,728,164	2.7%
2001	27,883,010	34,967,917	38,162,815	36,003,199	137,016,941	7.3%
2002	28,916,700	34,624,807	38,168,856	34,967,885	136,678,248	-0.2%
2003	31,093,476	29,801,554	31,351,738	29,068,027	121,314,795	-11.2%
2004	29,545,991	36,253,288	40,042,718	33,531,865	139,373,862	14.9%
2005	29,608,133	37,518,001	42,697,902	35,712,018	145,536,054	4.4%
2006	32,390,215	41,096,929	45,216,664	37,936,787	156,640,595	7.6%
2007	34,313,793	43,096,842	48,556,382	41,110,361	167,077,378	6.7%
2008	36,199,394	44,860,208	52,374,003	42,457,879	175,891,484	5.3%
2009	37,357,908	46,504,382			83,862,290	
Change	3.2%	3.7%				

Table 3.26

Kenai Annual Non-Taxable Sales by Quarter - in \$						
	1st Quarter	2nd Quarter	3rd Quarter	4th Quarter	Total	Annual Change
1994	32,588,300	31,084,003	43,458,497	27,683,755	134,814,555	
1995	24,219,228	34,860,364	71,443,657	24,982,823	155,506,072	15.3%
1996	20,450,801	29,181,304	55,990,061	26,557,331	132,179,497	-15.0%
1997	22,999,598	39,319,510	58,166,504	39,034,011	159,519,623	20.7%
1998	34,711,421	39,769,783	51,916,105	35,651,924	162,049,233	1.6%
1999	24,126,000	30,699,979	57,320,534	34,232,514	146,379,027	-9.7%
2000	30,088,063	34,610,658	52,871,203	38,346,414	155,916,338	6.5%
2001	34,529,045	41,685,267	56,748,686	40,419,503	173,382,501	11.2%
2002	31,569,236	33,193,774	44,298,770	33,555,786	142,617,566	-17.7%
2003	30,944,257	37,404,497	49,798,580	43,420,366	161,567,700	13.3%
2004	31,526,513	44,124,301	57,817,669	134,429,830	267,898,313	65.8%
2005	46,033,388	65,025,221	69,642,606	139,542,683	320,243,898	19.5%
2006	30,883,425	68,181,789	76,321,274	124,904,961	300,291,449	-6.2%
2007	62,364,572	68,863,530	104,439,452	117,812,142	353,479,696	17.7%
2008	72,612,681	101,720,255	130,114,480	127,337,656	431,785,072	22.2%
2009	42,635,613	58,520,790			101,156,403	
Change	-41.3%	-42.5%				

Table 3.27

Kenai Construction

Kenai 2nd Quarter Permit VALUES by Type - 2003 -2009 in \$								
	2003	2004	2005	2006	2007	2008	2009	Annual Change
Residential New	1,943,000	1,079,000	1,883,500	3,383,000	3,934,500	2,432,000	1,421,400	-41.6%
Residential Alter/Add	515,200	52,200	131,300	305,700	706,900	309,300	130,700	-57.7%
Commercial New	0	81,000	45,000	60,000	889,000	14,746,100	1,288,200	-91.3%
Commercial Alter/Add	270,150	685,200	497,500	408,400	637,700	1,493,500	372,970	-75.0%
Total	2,728,350	1,897,400	2,557,300	4,157,100	6,168,100	18,980,900	3,213,270	-83.1%
Annual Change		-30.5%	34.8%	62.6%	48.4%	207.7%	-83.1%	

Table 3.28

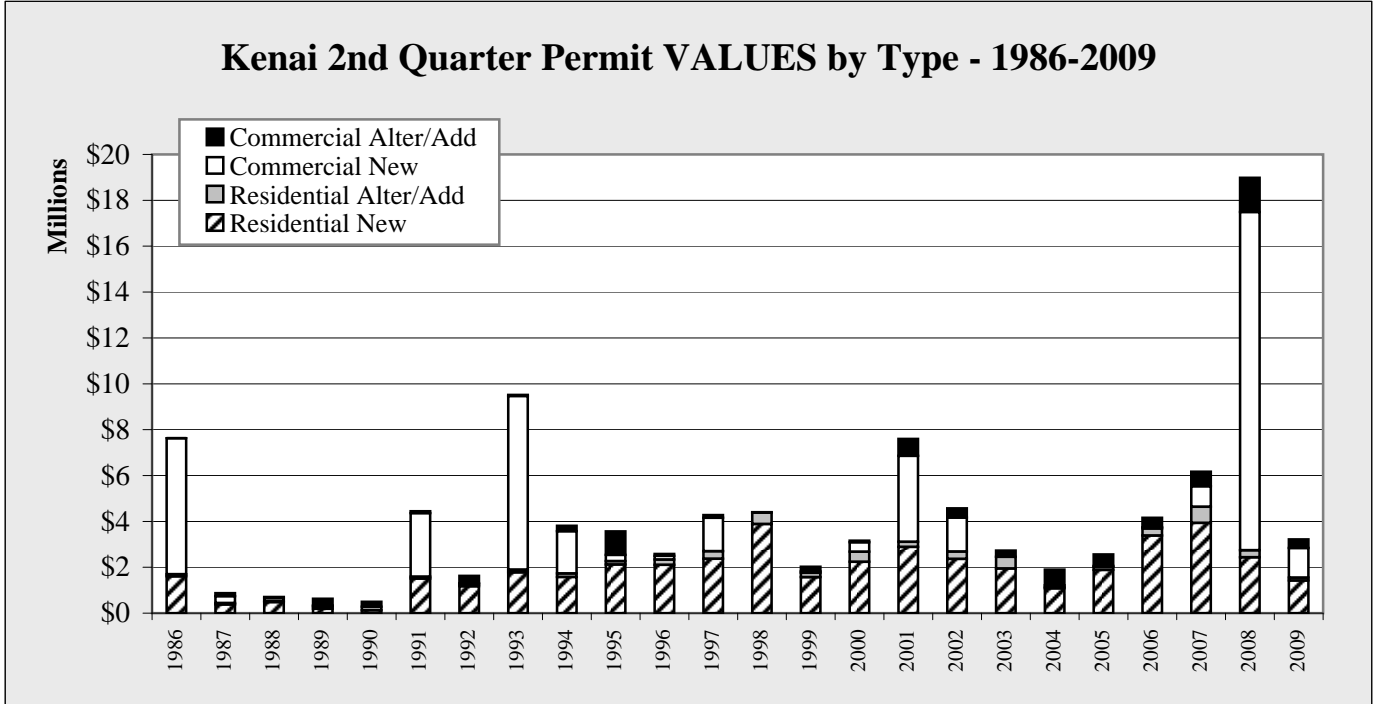

Chart 3.19

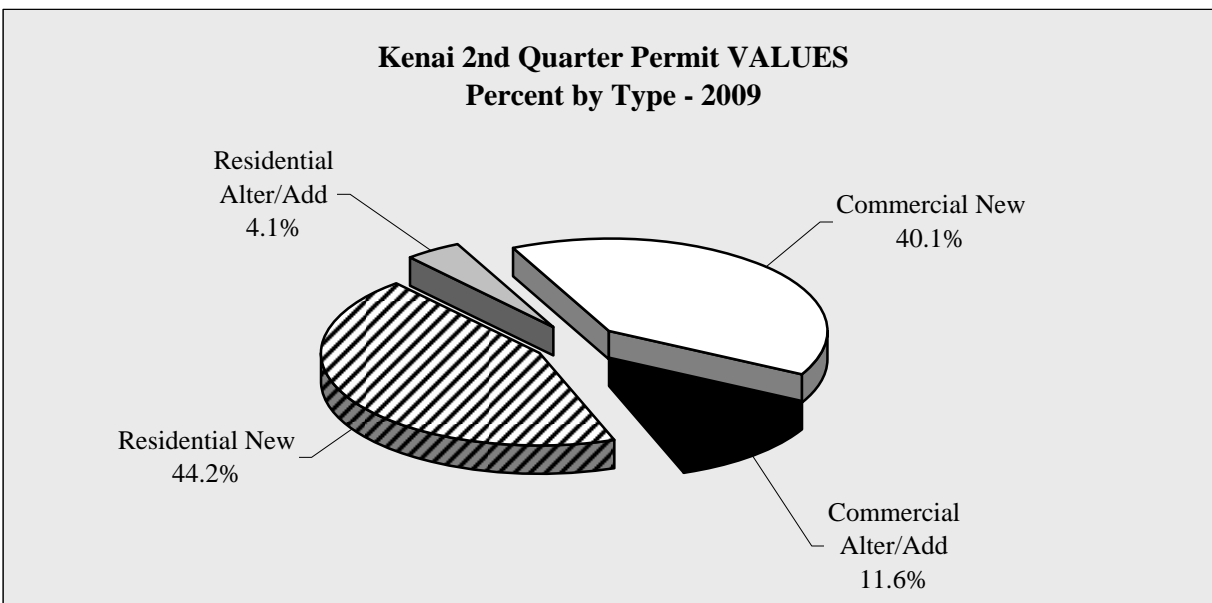

Chart 3.20

Kenai Construction

Kenai 2nd Quarter Permit VOLUME by Type - 2003-2009

	2003	2004	2005	2006	2007	2008	2009	Annual Change
Residential New	13	5	11	16	17	10	10	0.0%
Residential Alter/Add	16	8	11	16	15	17	9	-47.1%
Commercial New	0	2	2	1	2	3	2	-33.3%
Commercial Alter/Add	11	15	9	9	9	15	10	-33.3%
Total	40	30	33	42	43	45	31	-31.1%
Annual Change		-25.0%	10.0%	27.3%	2.4%	4.7%	-31.1%	

Table 3.29

Kenai 2nd Quarter Permit VOLUME by Type - 1986-2009

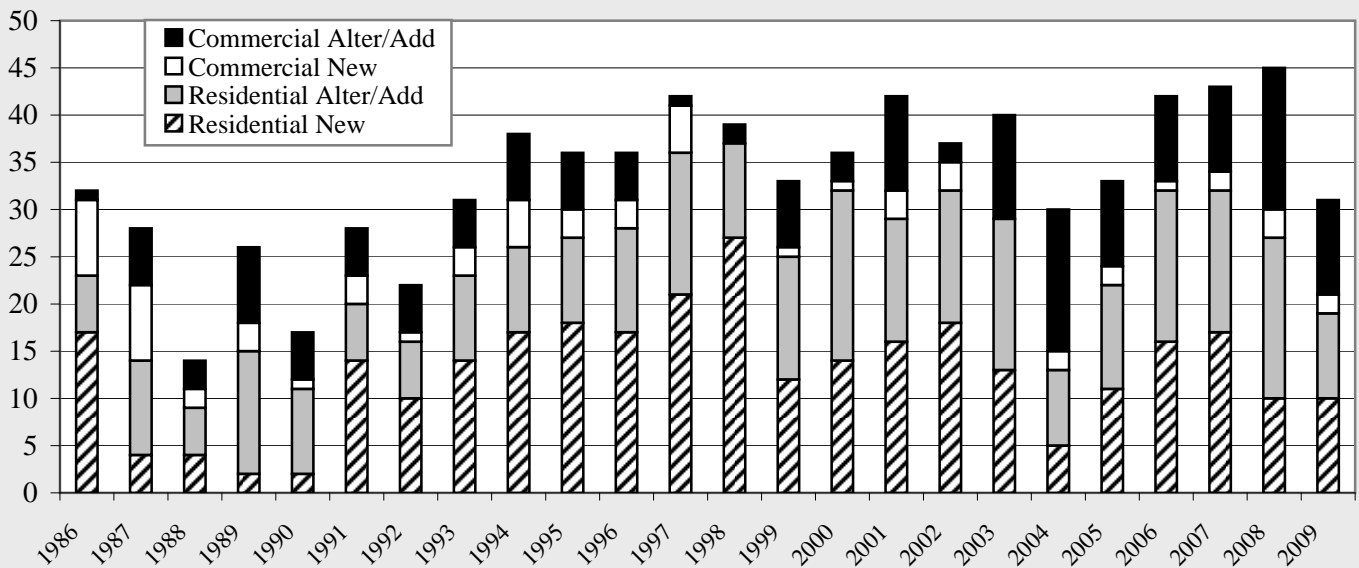

Chart 3.21

**Kenai 2nd Quarter Permit VOLUME
Percent by Type - 2009**

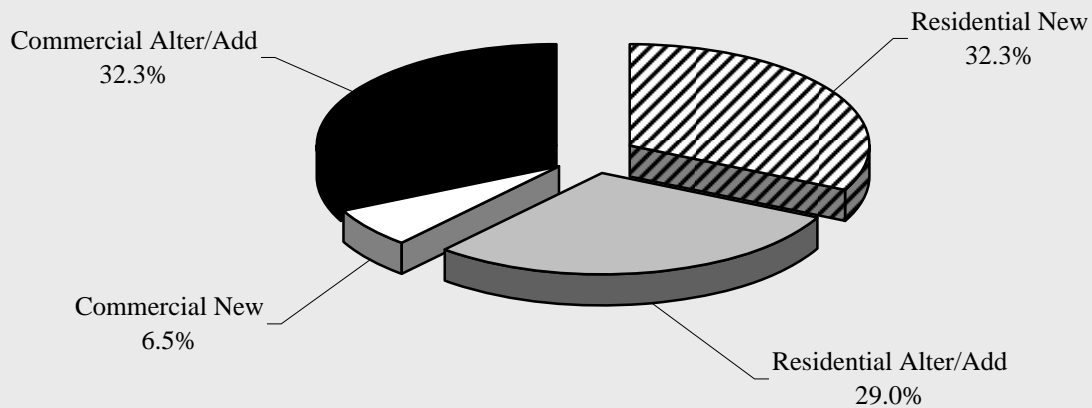

Chart 3.22

Kenai Construction

Kenai YTD 6/30 Permit VALUES by Type - 2003-2009- in \$								
	2003	2004	2005	2006	2007	2008	2009	Annual Change
Residential New	1,943,000	1,379,000	1,883,500	3,761,000	4,461,500	2,432,000	1,421,400	-41.6%
Residential Alter/Add	530,200	64,200	265,800	339,700	850,900	374,300	265,200	-29.1%
Commercial New	0	81,000	45,000	60,000	889,000	14,746,100	1,363,200	-90.8%
Commercial Alter/Add	1,812,750	685,200	788,500	759,900	736,200	2,491,800	656,470	-73.7%
Total	4,285,950	2,209,400	2,982,800	4,920,600	6,937,600	20,044,200	3,706,270	-81.5%
Annual Change		-48.5%	35.0%	65.0%	41.0%	188.9%	-81.5%	

Table 3.30

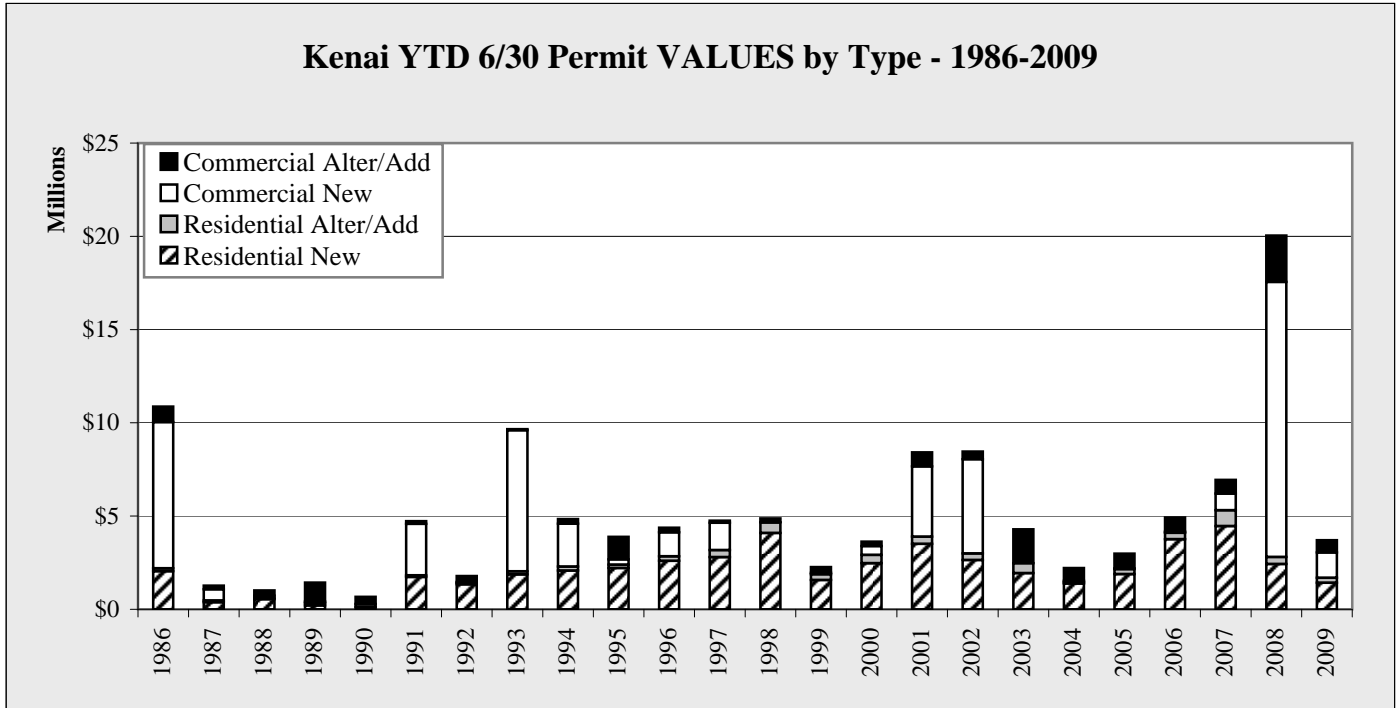

Chart 3.23

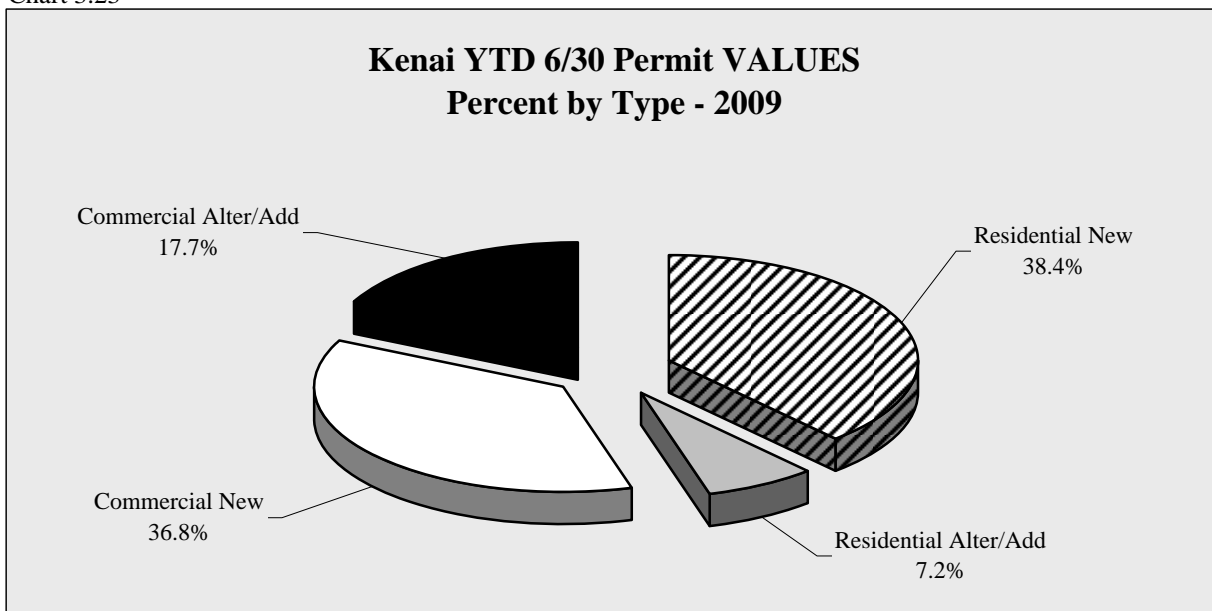

Chart 3.24

Kenai Construction

Kenai YTD 6/30 Permit VOLUME by Type - 2003-2009								
	2003	2004	2005	2006	2007	2008	2009	Annual Change
Residential New	13	8	11	18	21	10	10	0.0%
Residential Alter/Add	17	9	18	19	20	20	13	-35.0%
Commercial New	0	2	2	1	2	3	3	0.0%
Commercial Alter/Add	18	15	12	18	11	24	14	-41.7%
Total	48	34	43	56	54	57	40	-29.8%
Annual Change		-29.2%	26.5%	30.2%	-3.6%	5.6%	-29.8%	

Table 3.31

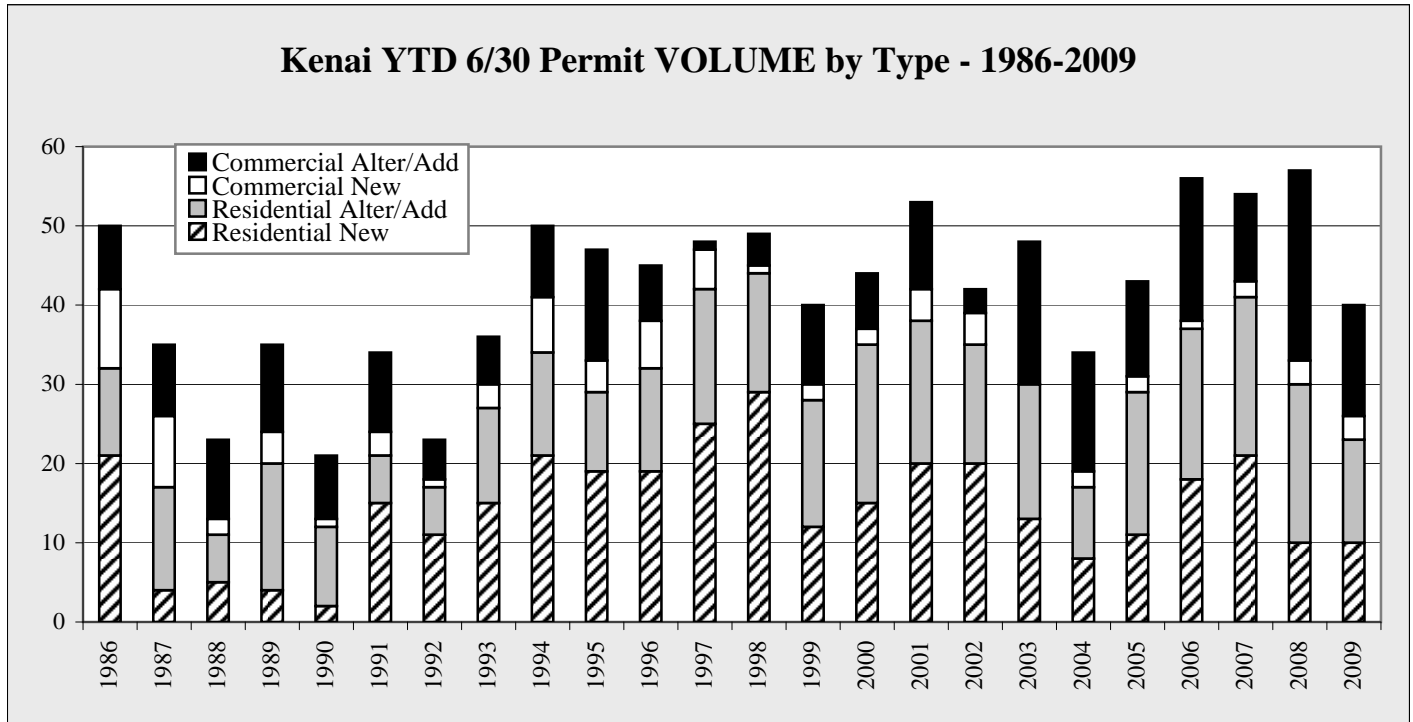

Chart 3.25

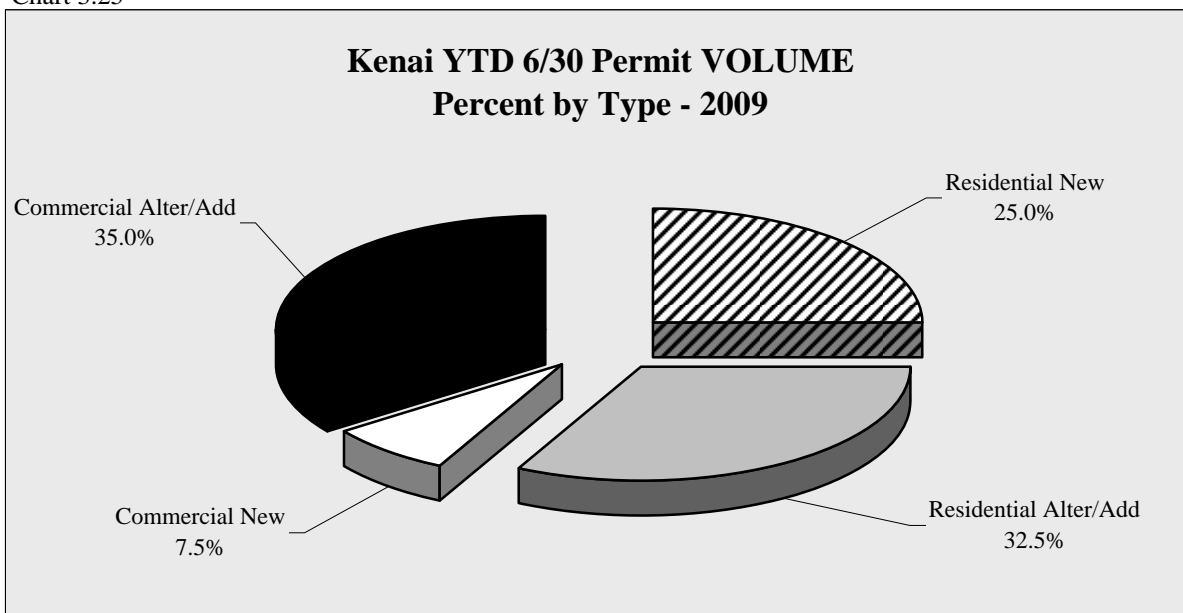

Chart 3.26

Kenai Construction

Kenai Annual Permit VALUES by Type by Quarter - 2002-2009 - in \$					
	1st Quarter	2nd Quarter	3rd Quarter	4th Quarter	Total
2002					
Residential - New	279,000	2,362,000	2,899,000	377,000	5,917,000
Residential - Add/Alter	28,000	323,100	302,400	70,000	723,500
Commercial - New	3,579,200	1,480,000	212,000	990,000	6,261,200
Commercial - Add/Alter	2,000	404,300	3,400,600	90,800	3,897,700
TOTAL	3,888,200	4,569,400	6,814,000	1,527,800	16,799,400
2003					
Residential - New	0	1,943,000	560,000	779,000	3,282,000
Residential - Add/Alter	15,000	515,200	168,850	183,000	882,050
Commercial - New	0	0	51,000	253,000	304,000
Commercial - Add/Alter	1,542,600	270,150	2,920,500	1,240,500	5,973,750
TOTAL	1,557,600	2,728,350	3,700,350	2,455,500	10,441,800
2004					
Residential - New	300,000	1,079,000	1,197,500	482,000	3,058,500
Residential - Add/Alter	12,000	52,200	308,950	27,000	400,150
Commercial - New	0	81,000	250,000	0	331,000
Commercial - Add/Alter	0	685,200	235,300	76,400	996,900
TOTAL	312,000	1,897,400	1,991,750	585,400	4,786,550
2005					
Residential - New	0	1,883,500	1,544,000	946,000	4,373,500
Residential - Add/Alter	134,500	131,300	306,600	78,500	650,900
Commercial - New	0	45,000	1,000,000	128,000	1,173,000
Commercial - Add/Alter	291,000	497,500	1,184,500	67,500	2,040,500
TOTAL	425,500	2,557,300	4,035,100	1,220,000	8,237,900
2006					
Residential - New	378,000	3,383,000	2,324,500	1,334,000	7,419,500
Residential - Add/Alter	34,000	305,700	262,154	26,700	628,554
Commercial - New	0	60,000	175,000	375,000	610,000
Commercial - Add/Alter	351,500	408,400	1,606,000	52,200	2,418,100
TOTAL	763,500	4,157,100	4,367,654	1,787,900	11,076,154
2007					
Residential - New	527,000	3,934,500	1,247,000	0	5,708,500
Residential - Add/Alter	144,000	706,900	617,700	32,700	1,501,300
Commercial - New	0	889,000	6,475,000	0	7,364,000
Commercial - Add/Alter	98,500	637,700	6,681,000	407,000	7,824,200
TOTAL	769,500	6,168,100	15,020,700	439,700	22,398,000
2008					
Residential - New	0	2,432,000	1,898,500	730,875	5,061,375
Residential - Add/Alter	65,000	309,300	265,100	182,100	821,500
Commercial - New	0	14,746,100	22,265,000	60,000	37,071,100
Commercial - Add/Alter	998,300	1,493,500	547,700	493,000	3,532,500
TOTAL	1,063,300	18,980,900	24,976,300	1,465,975	46,486,475
2009					Year to Date
Residential - New	0	1,421,400			1,421,400
Residential - Add/Alter	134,500	130,700			265,200
Commercial - New	75,000	1,288,200			1,363,200
Commercial - Add/Alter	283,500	372,970			656,470
TOTAL	493,000	3,213,270			3,706,270

Table 3.32

Kenai Construction

Kenai Annual Permit VOLUME by Type by Quarter - 2002-2009					
	1st Quarter	2nd Quarter	3rd Quarter	4th Quarter	Total
2002					
Residential - New	2	18	19	3	42
Residential - Add/Alter	1	14	26	4	45
Commercial - New	1	3	2	3	9
Commercial - Add/Alter	1	2	12	10	25
TOTAL	5	37	59	20	121
2003					
Residential - New	0	13	3	6	22
Residential - Add/Alter	1	16	22	5	44
Commercial - New	0	0	2	2	4
Commercial - Add/Alter	7	11	18	8	44
TOTAL	8	40	45	21	114
2004					
Residential - New	3	5	8	4	20
Residential - Add/Alter	1	8	12	4	25
Commercial - New	0	2	1	0	3
Commercial - Add/Alter	0	15	10	6	31
TOTAL	4	30	31	14	79
2005					
Residential - New	0	11	8	5	24
Residential - Add/Alter	7	11	14	4	36
Commercial - New	0	2	1	1	4
Commercial - Add/Alter	3	9	10	4	26
TOTAL	10	33	33	14	90
2006					
Residential - New	2	16	14	5	37
Residential - Add/Alter	3	16	16	4	39
Commercial - New	0	1	1	1	3
Commercial - Add/Alter	9	9	12	4	34
TOTAL	14	42	43	14	113
2007					
Residential - New	4	17	12	0	33
Residential - Add/Alter	5	15	24	7	51
Commercial - New	0	2	4	0	6
Commercial - Add/Alter	2	9	4	7	22
TOTAL	11	43	44	14	112
2008					
Residential - New	0	10	11	4	25
Residential - Add/Alter	3	17	20	5	45
Commercial - New	0	3	3	1	7
Commercial - Add/Alter	9	15	8	5	37
TOTAL	12	45	42	15	114
2009					Year to Date
Residential - New	0	10			10
Residential - Add/Alter	4	9			13
Commercial - New	1	2			3
Commercial - Add/Alter	4	10			14
TOTAL	9	31			40

Table 3.33

SELDOVIA

Seldovia Sales

Seldovia Second Quarter GROSS Sales by Line of Business - 2004-2009 - in \$								
LOB	2004	2005	2006	2007	2008	2009	Annual Percent Change	Annual Amount Change
PROD	0	0	0	9	0	0	N/A	0
SALES	273,983	247,256	249,160	276,340	512,656	331,951	-35.2%	-180,705
CONST	763,635	448,535	164,132	816,558	413,111	167,711	-59.4%	-245,400
PROP	10,419	421,243	573,282	13,260	38,899	15,792	-59.4%	-23,107
TOUR	230,196	248,817	376,150	405,153	682,168	161,641	-76.3%	-520,527
SERV	90,448	89,641	84,535	193,044	136,079	116,516	-14.4%	-19,563
PROF	6,501	4,509	14,624	139,361	10,105	16,289	61.2%	6,184
UTIL	77,365	94,395	98,564	101,555	120,070	134,021	11.6%	13,951
MANU	8,348	519	2,027	1,602	2,236	285	-87.3%	-1,951
TRAN	85,976	88,970	83,706	63,525	1,629	3,977	144.1%	2,348
WHLS	336,856	395,869	418,821	463,239	567,188	453,848	-20.0%	-113,340
GOV	87,943	80,780	105,810	76,504	107,524	135,630	26.1%	28,106
TOTAL	1,971,670	2,120,534	2,170,811	2,550,150	2,591,665	1,537,661	-40.7%	-1,054,004

Table 4.1 For complete listing of Lines of Business, see page 17

Seldovia Second Quarter GROSS Sales History	
2004	1,971,670
2005	2,120,534
2006	2,170,811
2007	2,550,150
2008	2,591,665
2009	1,537,661

Table 4.2

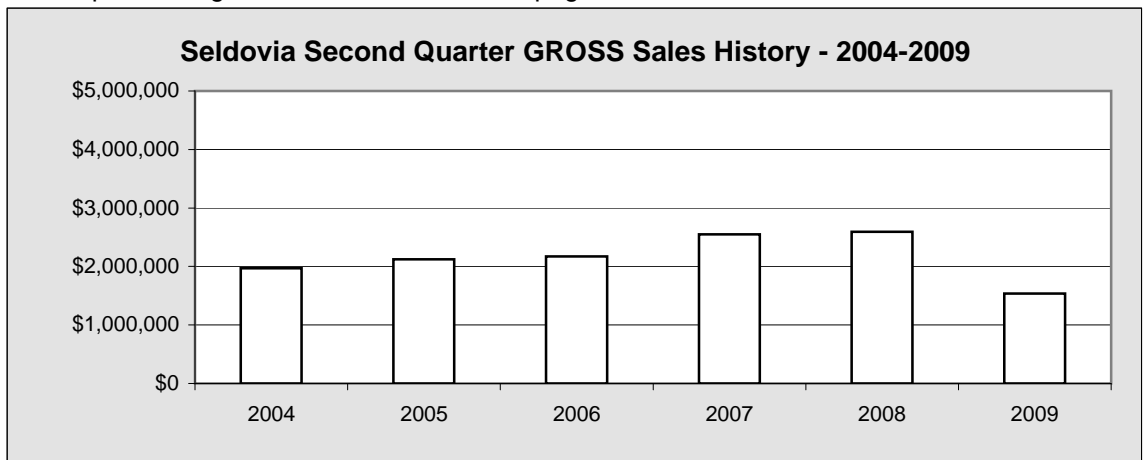

Chart 4.1

Seldovia Five Year Change Second Quarter GROSS Sales		
LOB	2004	2009
PROD	0	0
SALES	273,983	331,951
CONST	763,635	167,711
PROP	10,419	15,792
TOUR	230,196	161,641
SERV	90,448	116,516
PROF	6,501	16,289
UTIL	77,365	134,021
MANU	8,348	285
TRAN	85,976	3,977
WHLS	336,856	453,848
GOV	87,943	135,630
TOTAL	1,971,670	1,537,661

Table 4.3

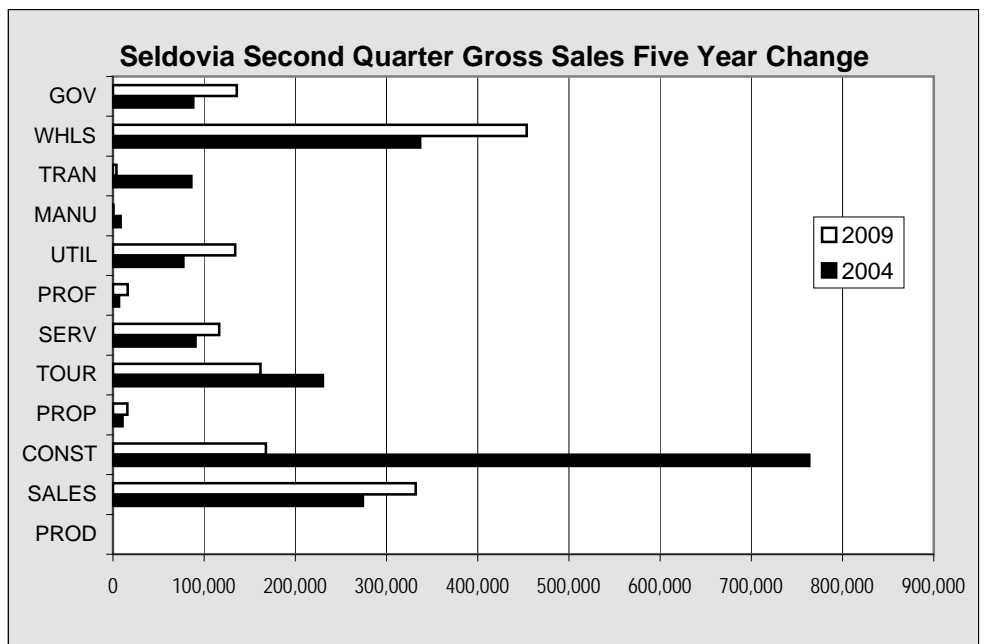

Chart 4.2

Seldovia Sales

Seldovia Second Quarter TAXABLE Sales by Line of Business - 2004-2009 - in \$

LOB	2004	2005	2006	2007	2008	2009	Annual Percent Change	Annual Amount Change
PROD	0	0	0	1	0	0	N/A	0
SALES	237,920	218,035	216,749	251,916	479,332	310,973	-35.1%	-168,359
CONST	8,058	7,615	7,858	7,079	15,615	4,980	-68.1%	-10,635
PROP	8,789	8,763	9,352	6,831	12,425	9,121	-26.6%	-3,304
TOUR	221,568	226,325	267,936	380,203	635,922	132,430	-79.2%	-503,492
SERV	61,844	57,099	51,270	128,901	74,669	76,473	2.4%	1,804
PROF	5,876	3,609	12,607	12,084	8,769	7,959	-9.2%	-810
UTIL	45,563	53,250	54,926	58,972	64,635	70,529	9.1%	5,894
MANU	1,748	107	27	500	1,328	102	-92.3%	-1,226
TRAN	47,888	54,047	27,853	29,148	0	590	N/A	590
WHLS	233,008	235,860	263,478	286,917	311,100	283,057	-9.0%	-28,043
GOV	67,327	67,431	62,443	57,503	59,596	61,791	3.7%	2,195
TOTAL	939,589	932,141	974,499	1,220,055	1,663,391	958,005	-42.4%	-705,386

Table 4.4

For complete listing of Lines of Business, see page 17

Seldovia Second Quarter TAXABLE Sales History	
2004	939,589
2005	932,141
2006	974,499
2007	1,220,055
2008	1,663,391
2009	958,005

Table 4.5

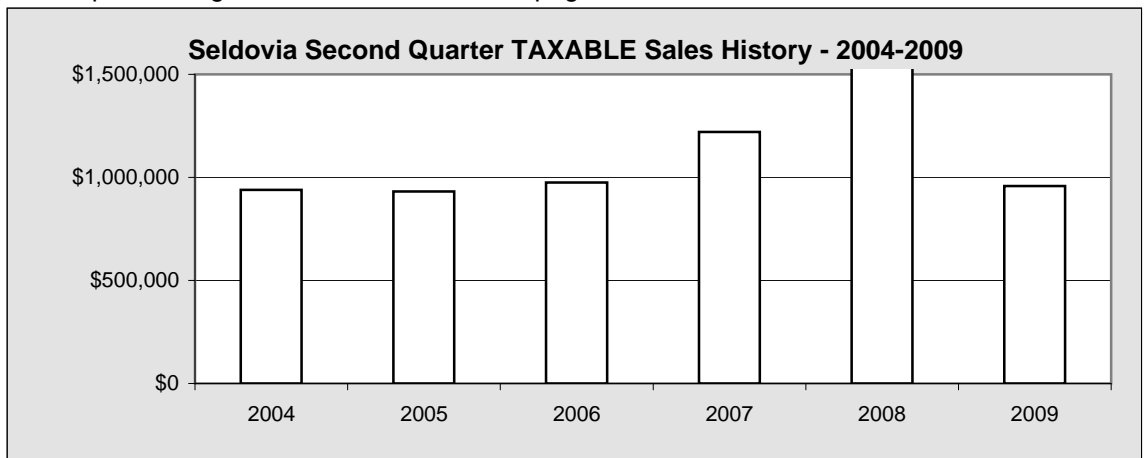

Chart 4.3

Seldovia Five Year Change Second Quarter TAXABLE Sales		
LOB	2004	2009
PROD	0	0
SALES	237,920	310,973
CONST	8,058	4,980
PROP	8,789	9,121
TOUR	221,568	132,430
SERV	61,844	76,473
PROF	5,876	7,959
UTIL	45,563	70,529
MANU	1,748	102
TRAN	47,888	590
WHLS	233,008	283,057
GOV	67,327	61,791
TOTAL	939,589	958,005

Table 4.6

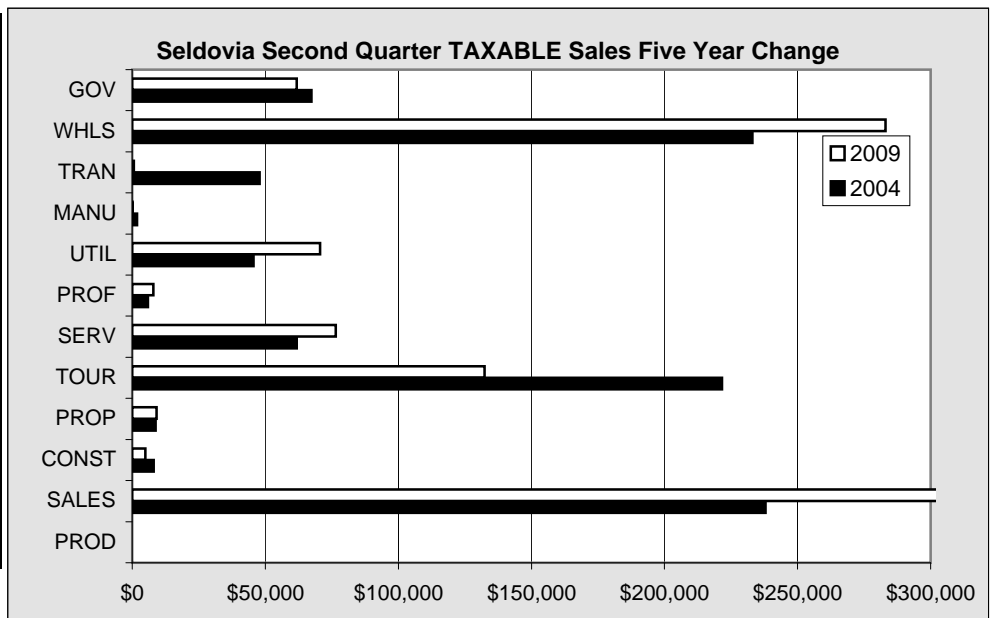

Chart 4.4

Seldovia Sales

Seldovia YTD June 30 GROSS Sales by Line of Business - 2004-2009 - in \$

LOB	2004	2005	2006	2007	2008	2009	Annual Percent Change	Annual Amount Change
PROD	0	0	0	25	0	0	N/A	0
SALES	463,264	404,135	393,904	443,754	167,995	577,071	243.5%	409,076
CONST	1,365,187	883,194	273,888	946,239	192,856	296,324	53.7%	103,468
PROP	20,389	434,864	992,789	41,342	16,790	32,626	94.3%	15,836
TOUR	317,719	354,694	475,390	735,194	212,166	210,312	-0.9%	-1,854
SERV	157,565	168,733	161,805	283,430	117,695	219,805	86.8%	102,110
PROF	17,861	8,213	22,557	190,397	46,535	28,834	-38.0%	-17,701
UTIL	163,419	184,812	217,751	227,196	122,500	315,734	157.7%	193,234
MANU	9,374	6,718	11,617	2,286	5,008	528	-89.5%	-4,480
TRAN	86,080	89,324	120,013	63,762	1,629	6,230	282.4%	4,601
WHLS	619,197	699,656	794,471	878,987	485,090	934,366	92.6%	449,276
GOV	156,662	147,926	223,746	203,834	139,938	291,787	108.5%	151,849
TOTAL	3,376,717	3,382,269	3,687,931	4,016,446	1,508,202	2,913,617	93.2%	1,405,415

Table 4.7

For complete listing of Lines of Business, see page 17

Seldovia YTD June 30 GROSS Sales History

2004	3,376,717
2005	3,382,269
2006	3,687,931
2007	4,016,446
2008	1,508,202
2009	2,913,617

Table 4.8

Seldovia YTD June 30 GROSS Sales History - 2004-2009

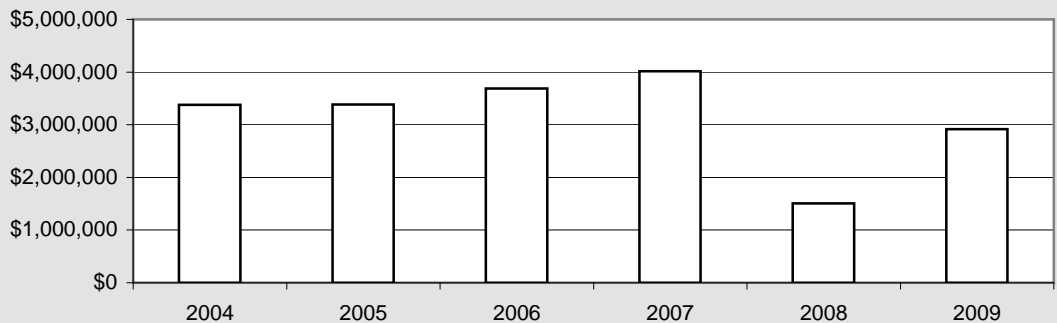

Chart 4.5

Seldovia Five Year Change YTD June 30 GROSS Sales

	2004	2009
PROD	0	0
SALES	463,264	577,071
CONST	1,365,187	296,324
PROP	20,389	32,626
TOUR	317,719	210,312
SERV	157,565	219,805
PROF	17,861	28,834
UTIL	163,419	315,734
MANU	9,374	528
TRAN	86,080	6,230
WHLS	619,197	934,366
GOV	156,662	291,787
TOTAL	3,376,717	2,913,617

Table 4.9

YTD June 30 Gross Sales Five Year Change

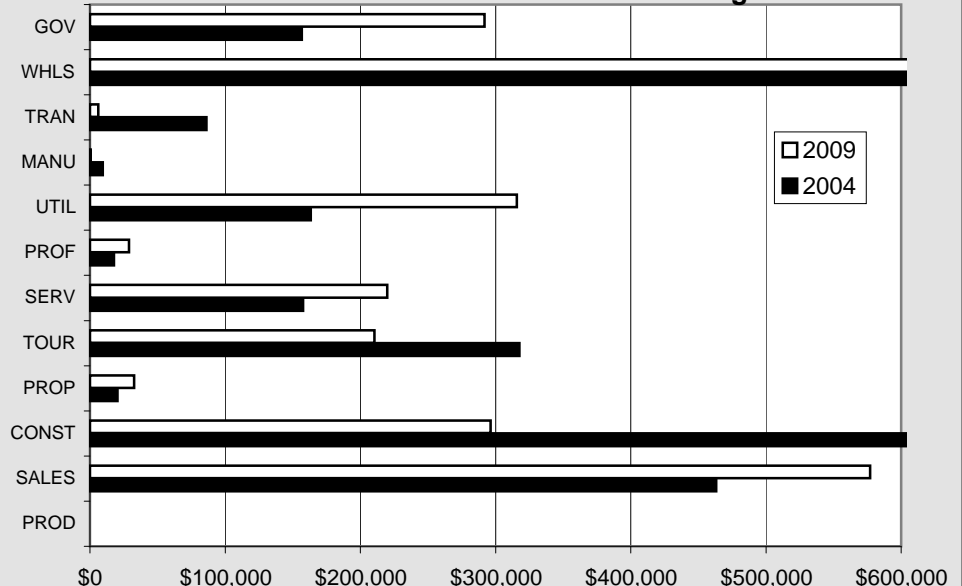

Chart 4.6

Seldovia Sales

Seldovia YTD June 30 TAXABLE Sales by Line of Business - 2004-2009 - in \$								
LOB	2004	2005	2006	2007	2008	2009	Annual Percent Change	Annual Amount Change
PROD	0	0	0	17	0	0	N/A	0
SALES	394,404	354,623	340,777	399,915	147,172	539,426	266.5%	392,254
CONST	12,934	12,270	14,843	14,510	4,582	12,436	171.4%	7,854
PROP	15,574	17,579	21,683	17,198	6,347	21,194	233.9%	14,847
TOUR	300,940	313,836	355,155	500,513	200,317	178,233	-11.0%	-22,084
SERV	110,482	109,374	107,282	193,013	56,560	138,115	144.2%	81,555
PROF	10,077	7,313	17,780	19,866	5,034	13,092	160.1%	8,058
UTIL	94,603	104,181	121,092	129,387	66,209	162,583	145.6%	96,374
MANU	2,325	5,806	2,840	1,119	500	345	-31.0%	-155
TRAN	47,992	54,401	28,149	29,385	0	590	N/A	590
WHLS	403,116	409,929	451,659	508,146	247,597	503,403	103.3%	255,806
GOV	113,868	115,846	149,933	163,789	106,386	165,280	55.4%	58,894
TOTAL	1,506,315	1,505,158	1,613,199	1,976,858	840,704	1,734,697	106.3%	893,993

Table 4.10 For complete listing of Lines of Business, see page 17

Seldovia YTD June 30 TAXABLE Sales History	
2004	1,506,315
2005	1,505,158
2006	1,613,199
2007	1,976,858
2008	840,704
2009	1,734,697

Table 4.11

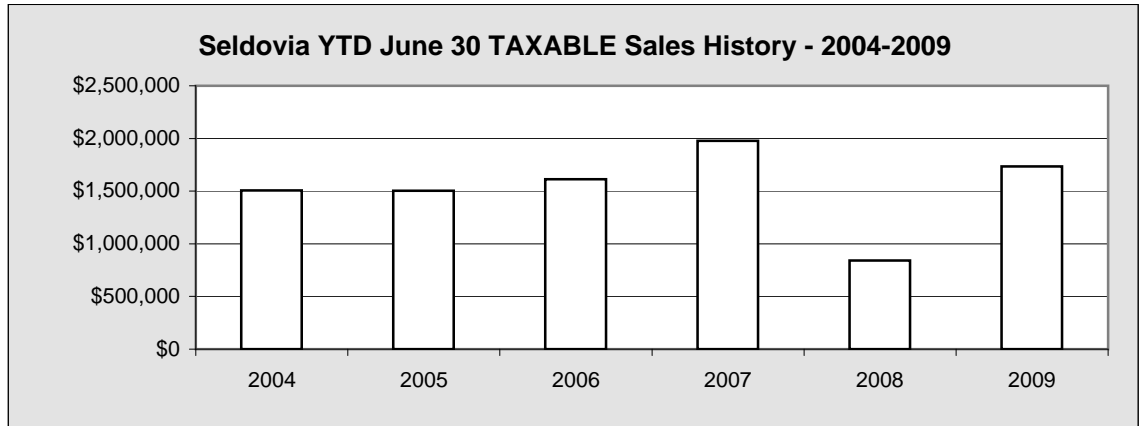

Chart 4.7

Seldovia Five Year Change YTD June 30 TAXABLE Sales		
	2004	2009
PROD	0	0
SALES	394,404	539,426
CONST	12,934	12,436
PROP	15,574	21,194
TOUR	300,940	178,233
SERV	110,482	138,115
PROF	10,077	13,092
UTIL	94,603	162,583
MANU	2,325	345
TRAN	47,992	590
WHLS	403,116	503,403
GOV	113,868	165,280
TOTAL	1,506,315	1,734,697

Table 4.12

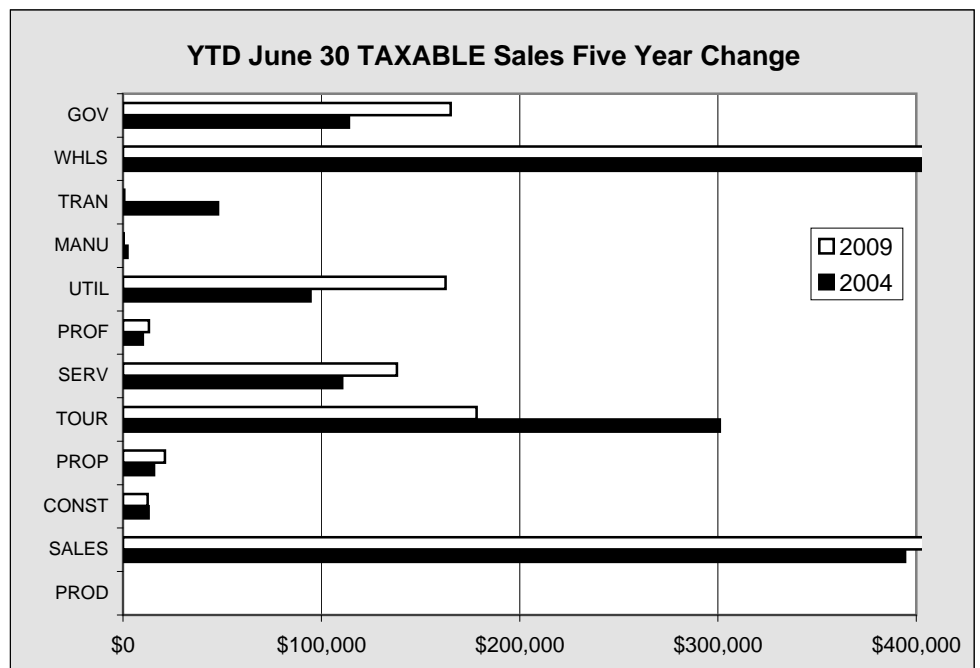

Chart 4.8

Seldovia Sales

Seldovia Annual GROSS Sales by Line of Business - 2003-2008 - in \$

LOB	2003	2004	2005	2006	2007	2008	Annual Percent Change	Annual Amount Change
PROD	0	0	0	0	17	5,674	NA	5,657
SALES	991,702	996,391	864,093	847,735	992,497	1,682,204	69.5%	689,707
CONST	2,241,387	2,431,728	1,482,392	1,030,138	2,962,633	1,723,873	-41.8%	-1,238,760
PROP	621,229	1,463,127	807,564	1,316,210	107,803	126,064	16.9%	18,261
TOUR	884,255	776,149	1,125,917	1,289,981	1,548,344	1,168,012	-24.6%	-380,332
SERV	298,039	344,487	349,754	406,193	671,443	669,621	-0.3%	-1,822
PROF	202,623	92,455	41,328	156,476	435,582	86,228	-80.2%	-349,354
UTIL	356,192	329,763	371,471	434,916	458,186	506,228	10.5%	48,042
MANU	8,028	23,842	24,294	12,259	11,163	31,667	183.7%	20,504
TRAN	205,819	264,611	7,314	69,793	19,151	8,374	-56.3%	-10,777
WHLS	1,174,485	1,306,023	1,486,381	1,598,598	1,921,275	2,086,580	8.6%	165,305
GOV	275,795	301,255	310,771	402,424	367,721	436,246	18.6%	68,525
TOTAL	7,259,554	8,329,831	6,871,279	7,564,723	9,495,815	8,530,771	-10.2%	-965,044

Table 4.13

For complete listing of Lines of Business, see page 17

Seldovia Annual GROSS Sales History	
2003	7,259,554
2004	8,329,831
2005	6,871,279
2006	7,564,723
2007	9,495,815
2008	8,530,771

Table 4.14

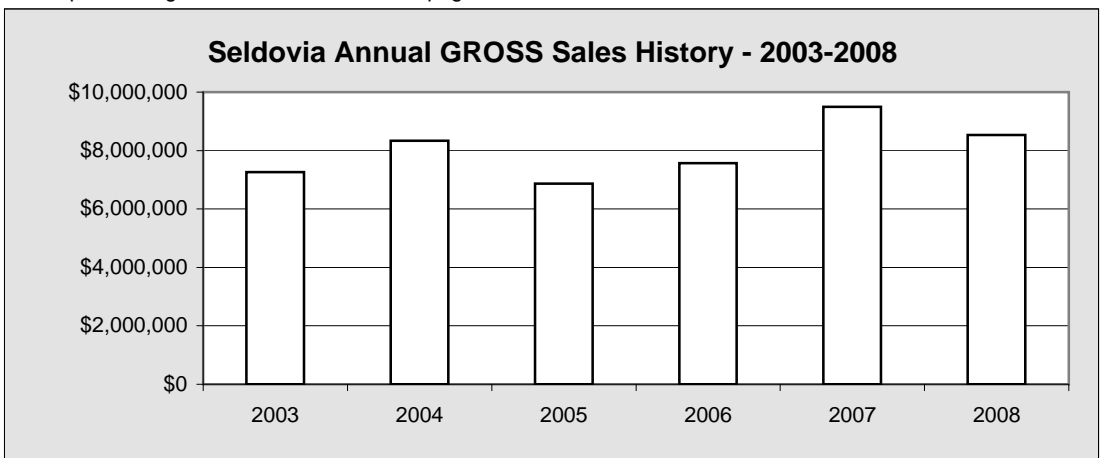
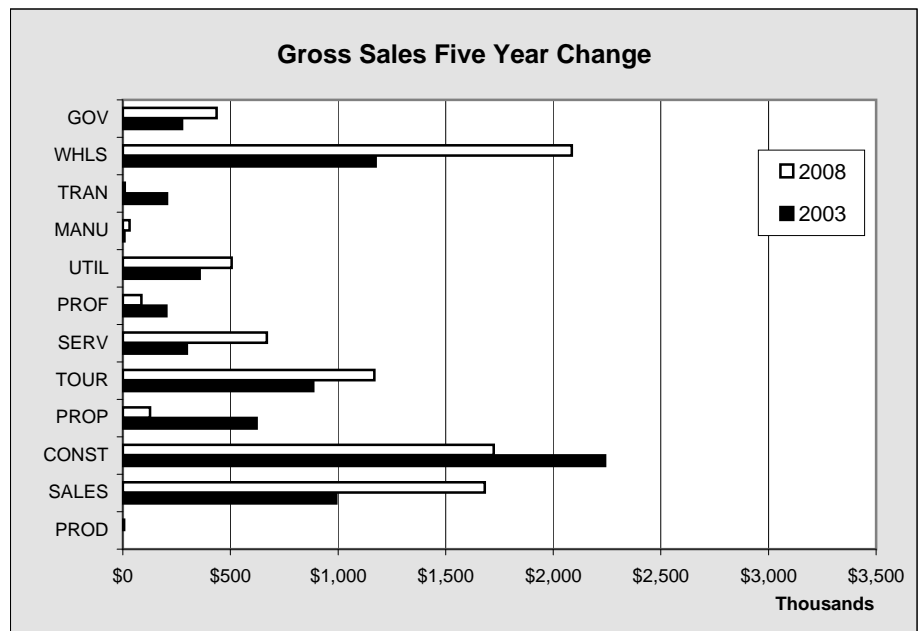

Chart 4.9

Five Year Change Annual GROSS Sales		
LOB	2003	2008
PROD	0	5,674
SALES	991,702	1,682,204
CONST	2,241,387	1,723,873
PROP	621,229	126,064
TOUR	884,255	1,168,012
SERV	298,039	669,621
PROF	202,623	86,228
UTIL	356,192	506,228
MANU	8,028	31,667
TRAN	205,819	8,374
WHLS	1,174,485	2,086,580
GOV	275,795	436,246
TOTAL	7,259,554	8,530,771

Table 4.15

Chart 4.10



Seldovia Sales

Seldovia Annual TAXABLE Sales by Line of Business - 2003-2008 - in \$								
LOB	2003	2004	2005	2006	2007	2008	Annual Percent Change	Annual Amount Change
PROD	0	0	0	0	16	1,000	NA	984
SALES	835,001	861,880	765,273	749,570	896,419	1,574,800	75.7%	678,381
CONST	29,348	26,204	29,768	34,880	40,834	58,927	44.3%	18,093
PROP	39,505	50,572	46,686	68,365	43,656	67,958	55.7%	24,302
TOUR	970,892	895,481	936,237	1,030,719	1,225,230	1,053,131	-14.0%	-172,099
SERV	258,334	231,604	239,046	278,269	459,263	461,563	0.5%	2,300
PROF	17,327	23,318	24,178	49,089	45,326	36,711	-19.0%	-8,615
UTIL	205,561	195,100	217,984	252,209	265,598	278,893	5.0%	13,295
MANU	2,027	8,636	8,788	3,230	3,849	6,015	56.3%	2,166
TRAN	837	0	1,216	1,962	1,061	1,415	33.4%	354
WHLS	766,780	856,967	880,245	930,613	1,055,721	1,168,921	10.7%	113,200
GOV	251,332	236,550	231,559	272,173	280,755	295,542	5.3%	14,787
TOTAL	3,376,944	3,386,312	3,380,980	3,671,079	4,317,728	5,004,876	15.9%	687,148

Table 4.16 For complete listing of Lines of Business, see page 17

Seldovia Annual TAXABLE Sales History	
2003	3,376,944
2004	3,386,312
2005	3,380,980
2006	3,671,079
2007	4,317,728
2008	5,004,876

Table 4.17

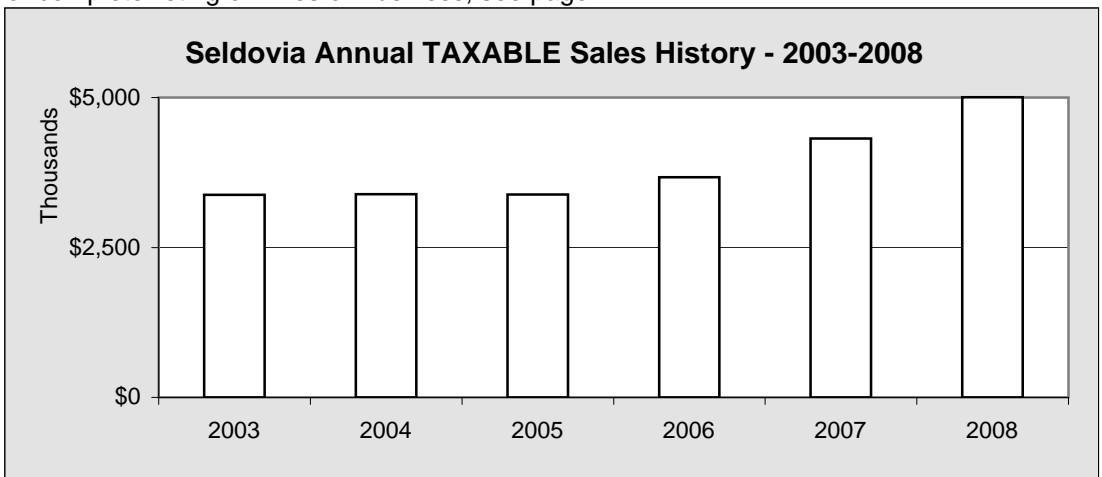

Chart 4.11

Five Year Change Annual TAXABLE Sales		
LOB	2003	2008
PROD	0	1,000
SALES	835,001	1,574,800
CONST	29,348	58,927
PROP	39,505	67,958
TOUR	970,892	1,053,131
SERV	258,334	461,563
PROF	17,327	36,711
UTIL	205,561	278,893
MANU	2,027	6,015
TRAN	837	1,415
WHLS	766,780	1,168,921
GOV	251,332	295,542
TOTAL	3,376,944	5,004,876

Table 4.18

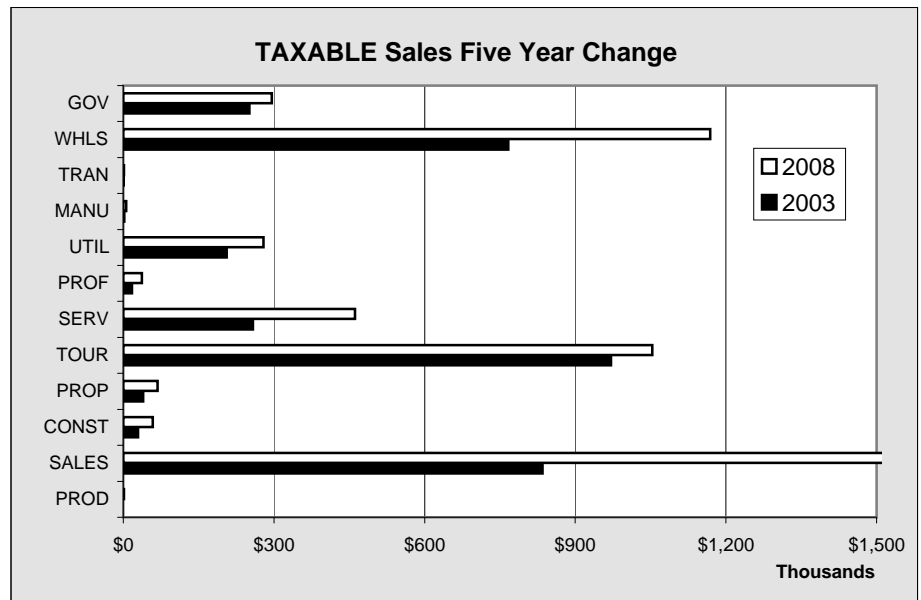

Chart 4.12

Seldovia Sales

Seldovia GROSS Sales by Line of Business by Quarter - 2008 - in \$					
	1st Quarter	2nd Quarter	3rd Quarter	4th Quarter	Total
Resource Production	0	0	5,674	0	5,674
Sales	264,462	512,656	599,427	305,659	1,682,204
Construction	192,856	413,111	335,473	782,433	1,723,873
Property	19,351	38,899	36,718	31,096	126,064
Tourism	115,750	682,168	355,826	14,268	1,168,012
Services	124,481	136,079	216,036	193,025	669,621
Professional	46,815	10,105	20,451	8,857	86,228
Utility	122,500	120,070	113,991	149,667	506,228
Manufacturing	5,008	2,236	6,749	17,684	31,677
Transportation & Warehousing	485,090	1,629	6,295	450	493,464
Wholesale	139,938	567,188	559,050	475,252	1,741,428
Government		107,524	91,471	97,313	296,308
TOTAL	1,516,251	2,591,665	2,347,161	2,075,704	8,530,781

Table 4.19

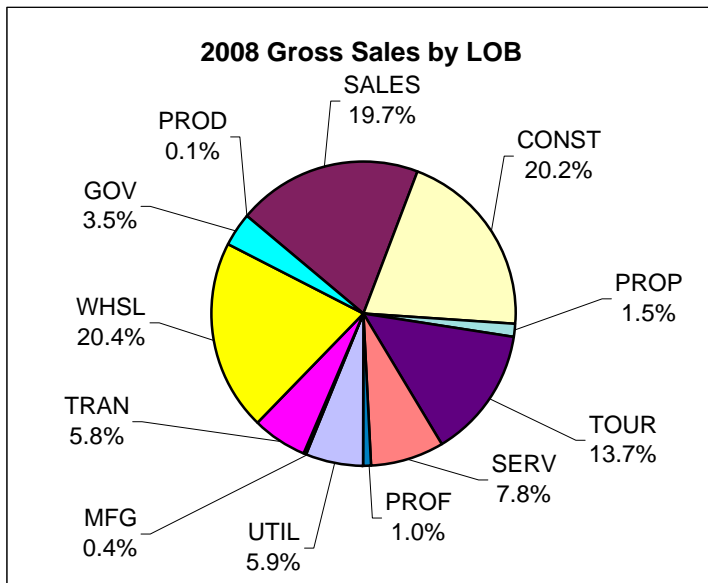

Chart 4.13

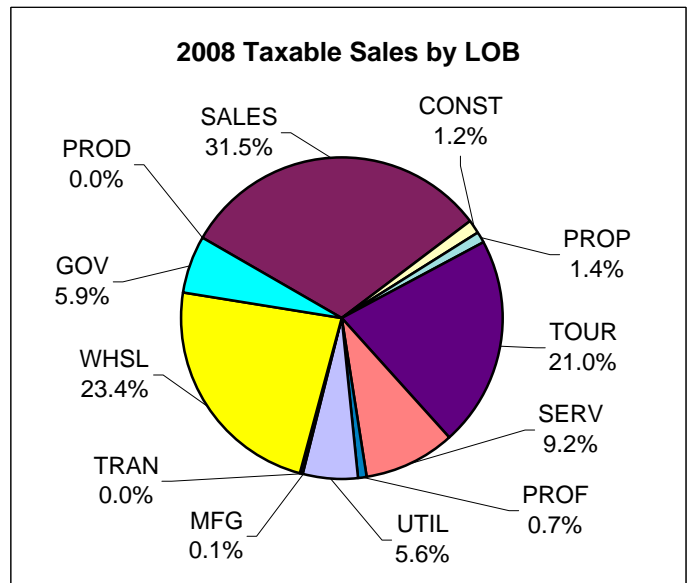

Chart 4.14

Seldovia TAXABLE Sales by Line of Business by Quarter - 2008 - in \$					
LOB	1st Quarter	2nd Quarter	3rd Quarter	4th Quarter	Total
Resource Production	0	0	1,000	0	1,000
Sales	243,606	479,332	576,652	275,210	1,574,800
Construction	4,582	15,615	23,549	15,181	58,927
Property	8,758	12,425	21,313	25,462	67,958
Tourism	103,934	635,922	308,331	4,944	1,053,131
Services	63,346	74,669	163,356	160,192	461,563
Professional	5,314	8,769	16,975	5,653	36,711
Utility	66,209	64,635	68,854	79,195	278,893
Manufacturing	500	1,328	3,667	520	6,015
Transportation & Warehousing	0	0	1,415	0	1,415
Wholesale	247,597	311,100	370,750	239,474	1,168,921
Government	106,386	59,596	78,158	51,402	295,542
TOTAL	850,232	1,663,391	1,634,020	857,233	5,004,876

Table 4.20

Seldovia Sales

Seldovia GROSS Sales by Line of Business by Quarter - 2007 - in \$					
LOB	1st Quarter	2nd Quarter	3rd Quarter	4th Quarter	Total
Resource Production	16	1	0	0	17
Sales	167,414	276,990	348,040	200,053	992,497
Construction	129,681	816,559	164,195	1,852,198	2,962,633
Property	24,309	13,260	11,291	58,943	107,803
Tourism	330,041	447,339	593,591	177,373	1,548,344
Services	90,387	204,058	225,604	151,394	671,443
Professional	51,036	139,361	100,724	144,461	435,582
Utility	125,641	101,555	117,755	113,235	458,186
Manufacturing	684	1,602	6,288	2,589	11,163
Transportation & Warehousing	237	10,325	848	7,741	19,151
Wholesale	415,748	463,239	478,446	563,842	1,921,275
Government	127,330	76,504	83,982	79,905	367,721
TOTAL	1,462,524	2,550,793	2,130,764	3,351,734	9,495,815

Table 4.21

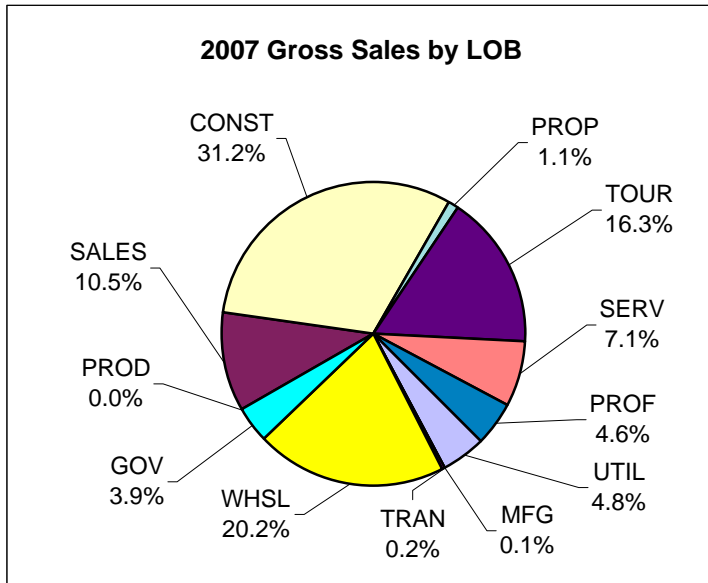

Chart 4.15

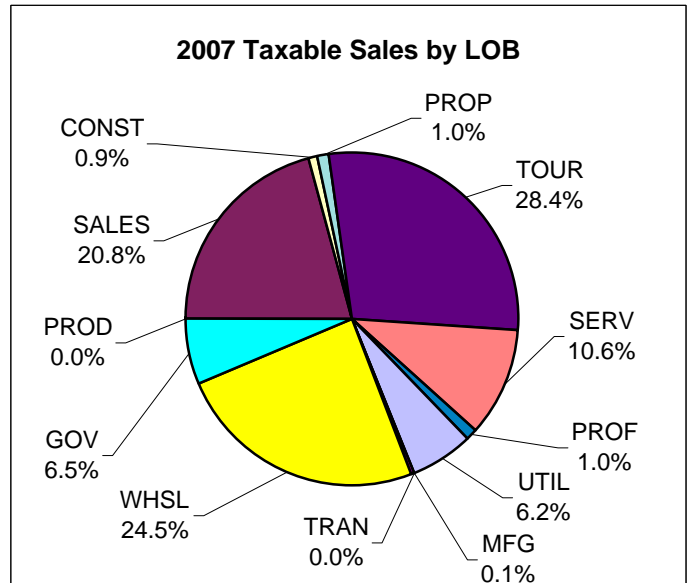

Chart 4.16

Seldovia TAXABLE Sales by Line of Business by Quarter - 2007 - in \$					
LOB	1st Quarter	2nd Quarter	3rd Quarter	4th Quarter	Total
Resource Production	16	0	0	0	16
Sales	147,999	252,567	316,004	179,849	896,419
Construction	7,431	7,079	8,383	17,941	40,834
Property	9,367	6,831	7,991	19,467	43,656
Tourism	120,309	402,587	543,693	158,641	1,225,230
Services	64,111	134,883	176,697	83,572	459,263
Professional	7,782	12,399	16,957	8,188	45,326
Utility	70,415	58,972	72,197	64,014	265,598
Manufacturing	619	500	1,673	1,057	3,849
Transportation & Warehousing	237	467	357	0	1,061
Wholesale	221,229	287,048	300,152	247,292	1,055,721
Government	106,286	57,503	64,772	52,194	280,755
TOTAL	755,801	1,220,836	1,508,876	832,215	4,317,728

Table 4.22

Seldovia Sales

Seldovia GROSS Sales by Line of Business by Quarter - 2006 - in \$					
LOB	1st Quarter	2nd Quarter	3rd Quarter	4th Quarter	Total
Resource Production	0	0	0	0	0
Sales	144,744	249,160	283,577	170,254	847,735
Construction	109,756	164,132	599,939	156,311	1,030,138
Property	419,507	573,282	260,066	63,355	1,316,210
Tourism	99,240	413,861	637,719	139,161	1,289,981
Services	77,270	104,192	127,272	97,459	406,193
Professional	7,933	14,624	18,226	115,693	156,476
Utility	119,187	98,564	95,245	121,920	434,916
Manufacturing	9,590	2,027	642	0	12,259
Transportation & Warehousing	36,307	26,338	933	6,215	69,793
Wholesale	375,650	418,821	414,788	389,339	1,598,598
Government	117,936	105,810	91,181	87,497	402,424
TOTAL	1,517,120	2,170,811	2,529,588	1,347,204	7,564,723

Table 4.23

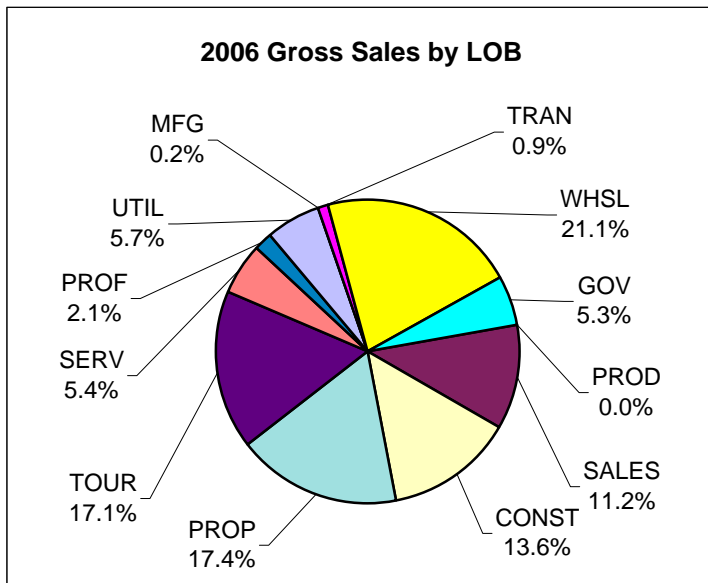

Chart 4.17

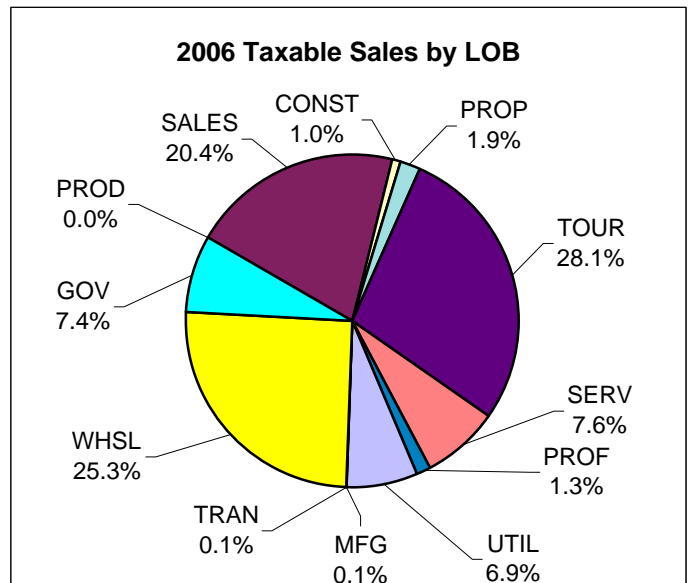

Chart 4.18

Seldovia TAXABLE Sales by Line of Business by Quarter - 2006 - in \$					
LOB	1st Quarter	2nd Quarter	3rd Quarter	4th Quarter	Total
Resource Production	0	0	0	0	0
Sales	124,028	216,749	258,004	150,789	749,570
Construction	6,985	7,858	12,958	7,079	34,880
Property	12,331	9,352	9,015	37,667	68,365
Tourism	87,219	287,228	545,954	110,318	1,030,719
Services	56,012	59,337	89,664	73,256	278,269
Professional	5,173	12,607	11,142	20,167	49,089
Utility	66,166	54,926	60,727	70,390	252,209
Manufacturing	2,813	27	390	0	3,230
Transportation & Warehousing	296	494	933	239	1,962
Wholesale	188,181	263,478	290,112	188,842	930,613
Government	87,490	62,443	69,165	53,075	272,173
TOTAL	636,694	974,499	1,348,064	711,822	3,671,079

Table 4.24

Seldovia Sales

Seldovia Annual Gross Sales by Quarter - in \$						
	1st Quarter	2nd Quarter	3rd Quarter	4th Quarter	Total	Annual Change
1994	821,959	1,395,585	1,707,670	1,350,093	5,275,307	
1995	962,895	1,802,578	1,869,108	1,203,280	5,837,861	10.7%
1996	864,931	1,406,053	2,438,766	1,020,242	5,729,992	-1.8%
1997	895,150	1,362,360	1,636,472	879,273	4,773,255	-16.7%
1998	935,674	1,331,163	1,584,201	872,701	4,723,739	-1.0%
1999	908,058	1,388,188	1,707,186	841,338	4,844,770	2.6%
2000	1,150,692	1,526,900	1,693,636	896,097	5,267,325	8.7%
2001	898,811	1,473,305	1,957,554	919,801	5,249,471	-0.3%
2002	1,011,712	1,155,055	1,694,174	956,936	4,817,877	-8.2%
2003	847,005	1,629,455	2,833,785	1,949,309	7,259,554	50.7%
2004	1,405,047	1,971,670	1,809,067	3,144,047	8,329,831	14.7%
2005	1,261,735	2,120,534	2,275,335	1,213,675	6,871,279	-17.5%
2006	1,517,120	2,170,811	2,529,588	1,347,204	7,564,723	10.1%
2007	1,462,524	2,550,793	2,130,764	3,351,734	9,495,815	25.5%
2008	1,516,251	2,591,665	2,347,161	2,075,704	8,530,781	-10.2%
2009	1,375,956	1,537,661			2,913,617	
Change	-9.3%	-40.7%				

Table 4.25

Seldovia Annual Taxable Sales by Quarter - in \$						
	1st Quarter	2nd Quarter	3rd Quarter	4th Quarter	Total	Annual Change
1994	511,011	868,198	1,061,682	636,294	3,077,185	
1995	602,805	981,822	1,306,693	685,628	3,576,948	16.2%
1996	578,650	996,975	1,184,616	670,068	3,430,309	-4.1%
1997	549,337	1,001,066	1,199,774	585,846	3,336,023	-2.7%
1998	529,660	1,000,949	1,251,027	616,657	3,398,293	1.9%
1999	569,438	915,962	1,144,627	599,222	3,229,249	-5.0%
2000	569,093	1,018,255	1,241,108	589,667	3,418,123	5.8%
2001	583,555	956,033	1,207,525	612,166	3,359,279	-1.7%
2002	573,624	898,830	1,191,989	607,946	3,272,389	-2.6%
2003	598,970	962,966	1,140,319	674,689	3,376,944	3.2%
2004	566,726	939,589	1,182,138	697,859	3,386,312	0.3%
2005	573,017	932,141	1,215,676	660,146	3,380,980	-0.2%
2006	636,694	974,499	1,348,064	711,822	3,671,079	8.6%
2007	755,801	1,220,836	1,508,876	832,215	4,317,728	17.6%
2008	850,232	1,663,391	1,634,020	857,233	5,004,876	15.9%
2009	776,692	958,005			1,734,697	
Change	-8.6%	-42.4%				

Table 4.26

Seldovia Annual Non-Taxable Sales by Quarter - in \$						
	1st Quarter	2nd Quarter	3rd Quarter	4th Quarter	Total	Annual Change
1994	310,948	527,387	645,988	713,799	2,198,122	
1995	360,090	820,756	562,415	517,652	2,260,913	2.9%
1996	286,281	409,078	1,254,150	350,174	2,299,683	1.7%
1997	345,813	361,294	436,698	293,427	1,437,232	-37.5%
1998	406,014	330,214	333,174	256,044	1,325,446	-7.8%
1999	338,620	472,226	562,559	242,116	1,615,521	21.9%
2000	581,599	508,645	452,528	306,430	1,849,202	14.5%
2001	315,256	517,272	750,029	307,635	1,890,192	2.2%
2002	438,088	256,225	502,185	348,990	1,545,488	-18.2%
2003	248,035	666,489	1,693,466	1,274,620	3,882,610	151.2%
2004	838,321	1,032,081	626,929	2,446,188	4,943,519	27.3%
2005	688,718	1,188,393	1,059,659	553,529	3,490,299	-29.4%
2006	880,426	1,196,312	1,181,524	635,382	3,893,644	11.6%
2007	706,723	1,329,957	621,888	2,519,519	5,178,087	33.0%
2008	666,019	928,274	713,141	1,218,471	3,525,905	-31.9%
2009	599,264	579,656				
Change	-10.0%	-37.6%				

Table 4.27

Seldovia Construction

Seldovia 2nd Quarter Permit VALUES by Type - 2003-2009 - in \$								
	2003	2004	2005	2006	2007	2008	2009	Annual Change
Residential New	0	150,000	300,000	55,000	227,000	0	300,000	NA
Residential Alter/Add	0	6,200	4,000	32,000	30,000	2,500	7,500	200.0%
Commercial New	0	0	8,000	0	2,000	0	0	NA
Commercial Alter/Add	0	0	154,000	0	8,000	5,000	0	NA
Total	0	156,200	466,000	87,000	267,000	7,500	307,500	4000.0%
Annual Change		NA	198.3%	-81.3%	206.9%	-97.2%	4000.0%	

Table 4.28

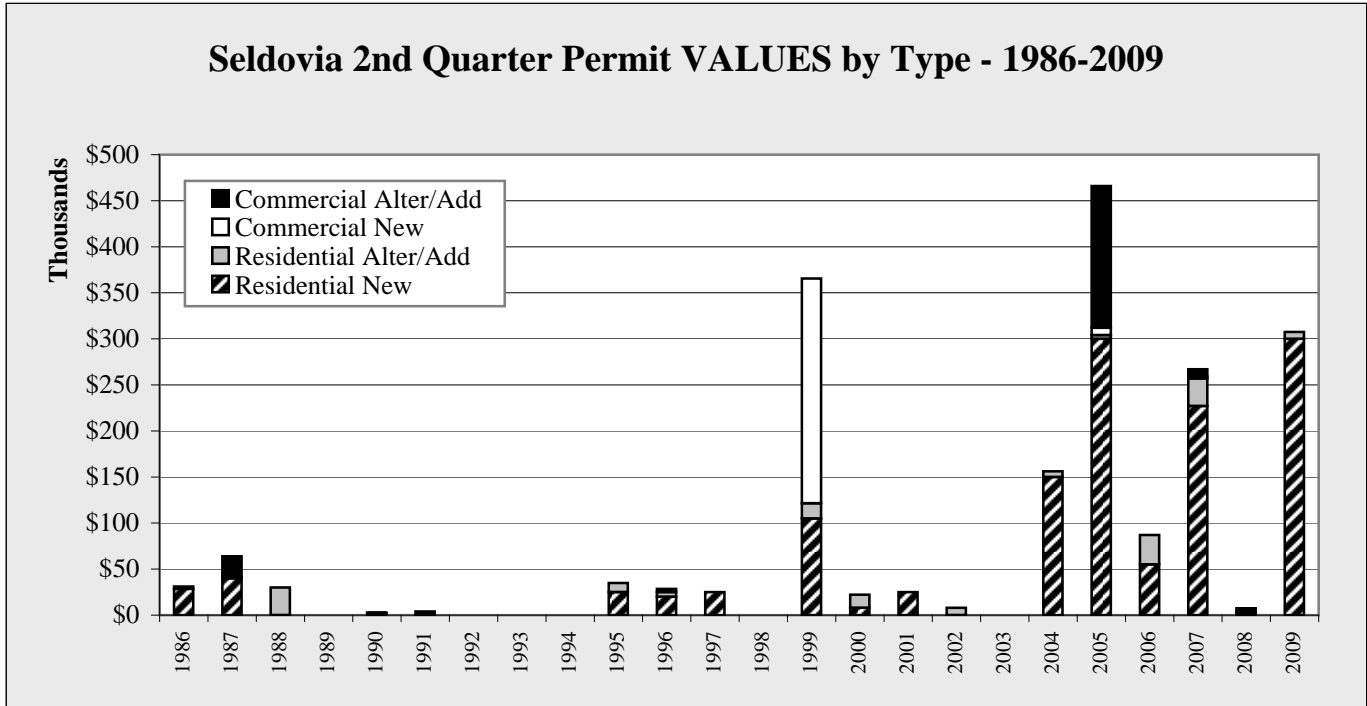

Chart 4.19

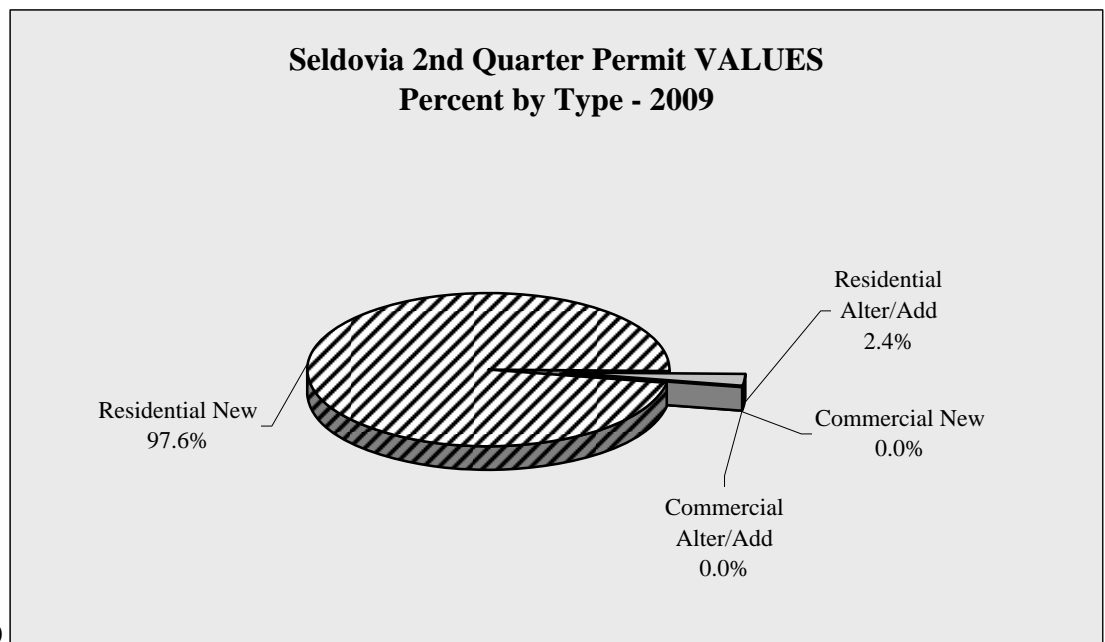

Chart 4.20

Seldovia Construction

Seldovia 2nd Quarter Permit VOLUME by Type - 2003-2009								
	2003	2004	2005	2006	2007	2008	2009	Annual Change
Residential New	0	1	2	2	3	0	1	NA
Residential Alter/Add	0	2	1	3	4	1	3	200.0%
Commercial New	0	0	1	0	1	0	0	NA
Commercial Alter/Add	0	0	2	1	1	1	0	-100.0%
Total	0	3	6	6	9	2	4	100.0%
Annual Change		NA	100.0%	NA	50.0%	-77.8%	100.0%	

Table 4.29

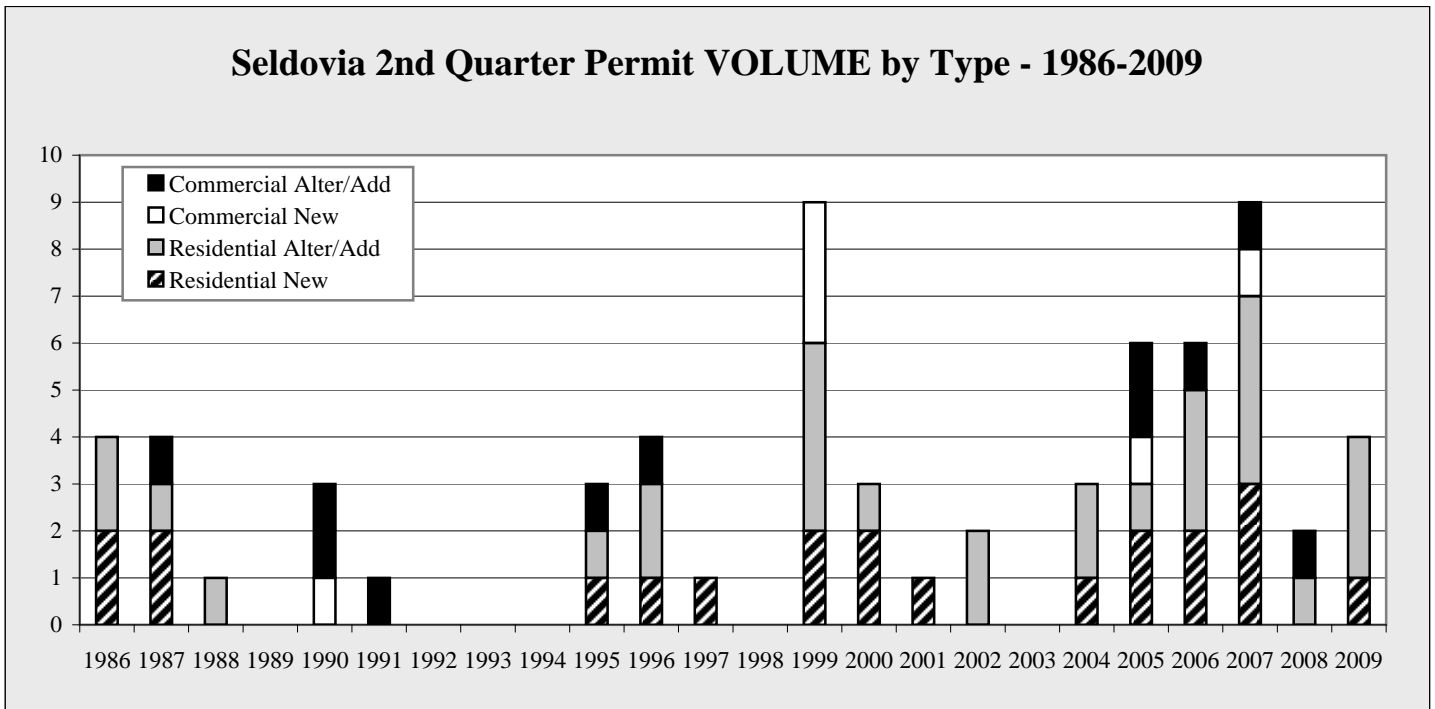

Chart 4.21

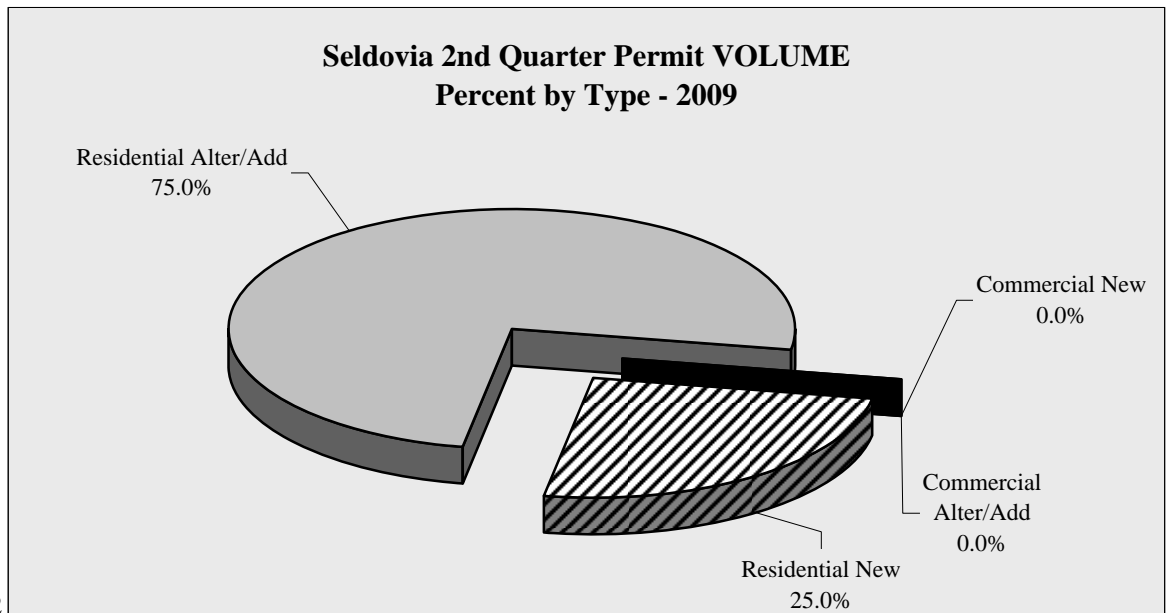

Chart 4.22

Seldovia Construction

Seldovia YTD 6/30 Permit VALUES by Type - 2003-2009 - in \$								
	2003	2004	2005	2006	2007	2008	2009	Annual Change
Residential New	0	170,000	300,000	85,000	227,000	0	300,000	NA
Residential Alter/Add	31,000	6,200	19,000	32,000	45,000	14,500	7,500	-48.3%
Commercial New	0	0	8,000	0	2,000	0	0	NA
Commercial Alter/Add	0	0	154,000	0	8,000	5,000	0	-100.0%
Total	31,000	176,200	481,000	117,000	282,000	19,500	307,500	1476.9%
Annual Change		468.4%	173.0%	-75.7%	141.0%	-93.1%	1476.9%	

Table 4.30

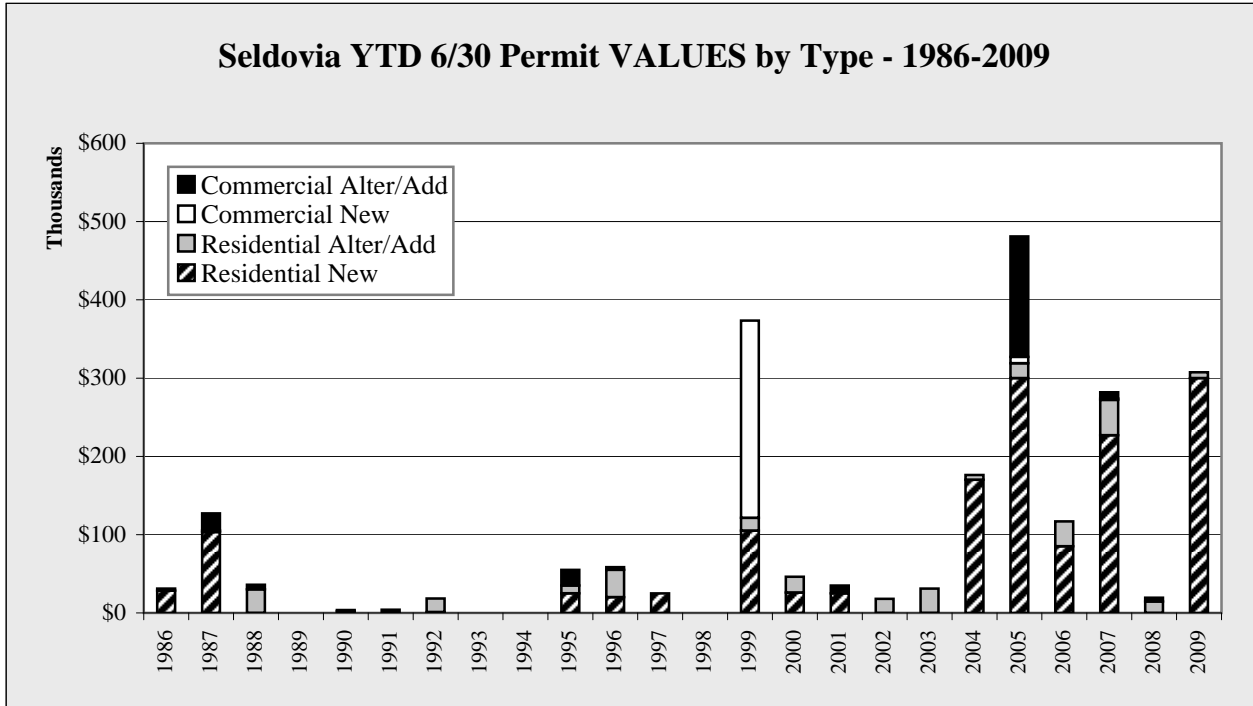

Chart 4.23

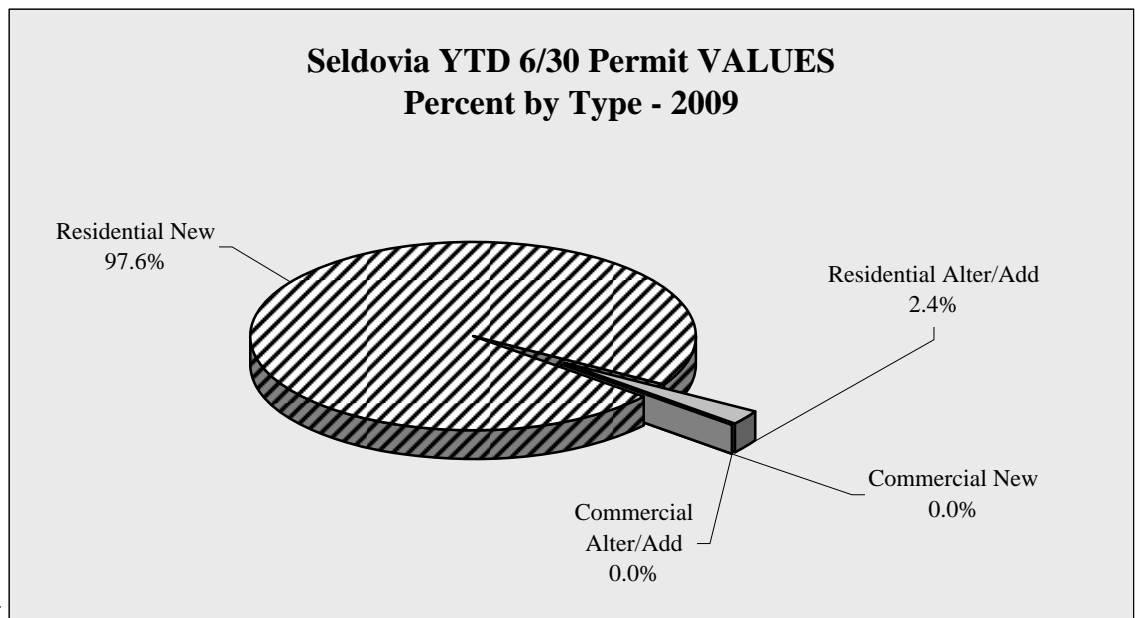

Chart 4.24

Seldovia Construction

Seldovia YTD 6/30 Permit VOLUME by Type - 2003-2009

	2003	2004	2005	2006	2007	2008	2009	Annual Change
Residential New	0	2	2	3	3	0	1	NA
Residential Alter/Add	3	2	2	3	5	2	3	50.0%
Commercial New	0	0	1	0	1	0	0	NA
Commercial Alter/Add	0	0	2	1	1	1	0	-100.0%
Total	3	4	7	7	10	3	4	33.3%
Annual Change		33.3%	75.0%	0.0%	42.9%	-70.0%	33.3%	

Table 4.31

Seldovia YTD 6/30 Permit VOLUME by Type - 1986-2009

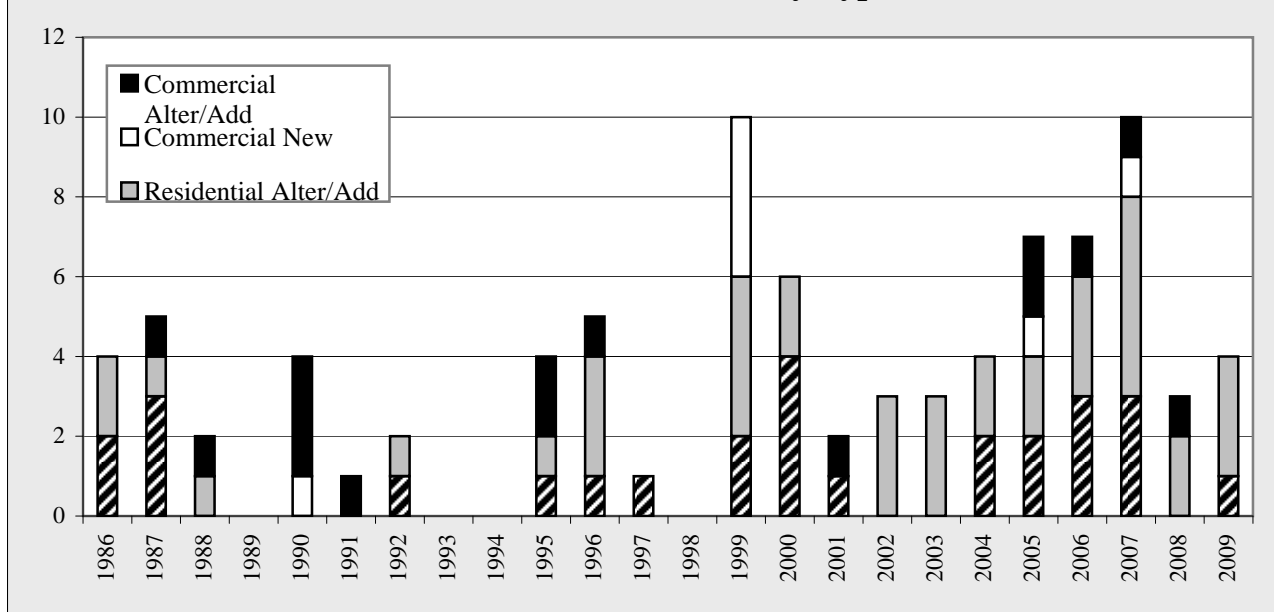

Chart 4.25

**Seldovia YTD 6/30 Permit VOLUME
Percent by Type - 2009**

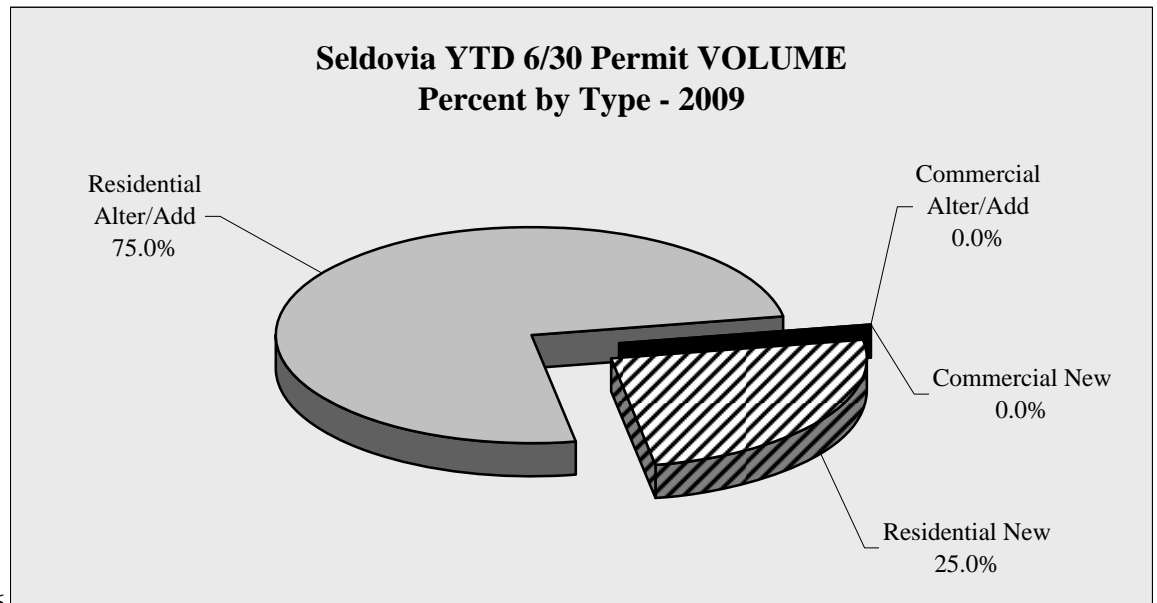

Chart 4.26

Seldovia Construction

Seldovia Annual Permit VALUES by Type by Quarter - 2002-2009 - in \$					
	1st Quarter	2nd Quarter	3rd Quarter	4th Quarter	Total
2002					
Residential - New	0	0	308,000	0	308,000
Residential - Add/Alter	10,000	8,000	10,500	20,000	48,500
Commercial - New	0	0	0	0	0
Commercial - Add/Alter	0	0	0	0	0
TOTAL	10,000	8,000	318,500	20,000	356,500
2003					
Residential - New	0	0	150,000	26,000	176,000
Residential - Add/Alter	31,000	0	0	3,000	34,000
Commercial - New	0	0	1,685,000	7,500	1,692,500
Commercial - Add/Alter	0	0	0	0	0
TOTAL	31,000	0	1,835,000	36,500	1,902,500
2004					
Residential - New	20,000	150,000	0	0	170,000
Residential - Add/Alter	0	6,200	0	0	6,200
Commercial - New	0	0	0	0	0
Commercial - Add/Alter	0	0	0	0	0
TOTAL	20,000	156,200	0	0	176,200
2005					
Residential - New	0	300,000	0	0	300,000
Residential - Add/Alter	15,000	4,000	30,000	0	49,000
Commercial - New	0	8,000	0	0	8,000
Commercial - Add/Alter	0	154,000	500	500	155,000
TOTAL	15,000	466,000	30,500	500	512,000
2006					
Residential - New	30,000	55,000	0	0	85,000
Residential - Add/Alter	0	32,000	0	0	32,000
Commercial - New	0	0	0	0	0
Commercial - Add/Alter	0	0	0	18,000	18,000
TOTAL	30,000	87,000	0	18,000	135,000
2007					
Residential - New	0	227,000	25,000	0	252,000
Residential - Add/Alter	15,000	30,000	15,800	1,000	61,800
Commercial - New	0	2,000	0	0	2,000
Commercial - Add/Alter	0	8,000	20,000	0	28,000
TOTAL	15,000	267,000	60,800	1,000	343,800
2008					
Residential - New	0	0	350,000	0	350,000
Residential - Add/Alter	12,000	2,500	0	10,000	24,500
Commercial - New	0	0	3,000	0	3,000
Commercial - Add/Alter	0	5,000	0	0	5,000
TOTAL	12,000	7,500	353,000	10,000	382,500
2009					
					Year to Date
Residential - New	0	300,000			300,000
Residential - Add/Alter	0	7,500			7,500
Commercial - New	0	0			0
Commercial - Add/Alter	0	0			0
TOTAL	0	307,500	0	0	307,500

Table 4.32

Seldovia Construction

Seldovia Annual Permit VOLUME by Type by Quarter - 2002-2009					
	1st Quarter	2nd Quarter	3rd Quarter	4th Quarter	Total
2002					
Residential - New	0	0	2	0	2
Residential - Add/Alter	1	2	2	1	6
Commercial - New	0	0	0	0	0
Commercial - Add/Alter	0	0	0	0	0
TOTAL	1	2	4	1	8
2003					
Residential - New	0	0	1	2	3
Residential - Add/Alter	3	0	0	1	4
Commercial - New	0	0	3	1	4
Commercial - Add/Alter	0	0	1	0	1
TOTAL	3	0	5	4	12
2004					
Residential - New	1	1	0	0	2
Residential - Add/Alter	0	2	0	0	2
Commercial - New	0	0	0	0	0
Commercial - Add/Alter	0	0	0	0	0
TOTAL	1	3	0	0	4
2005					
Residential - New	0	2	0	0	2
Residential - Add/Alter	1	1	1	0	3
Commercial - New	0	1	0	0	1
Commercial - Add/Alter	0	2	1	1	4
TOTAL	1	6	2	1	10
2006					
Residential - New	1	2	0	0	3
Residential - Add/Alter	0	3	0	0	3
Commercial - New	0	0	0	0	0
Commercial - Add/Alter	0	1	0	1	2
TOTAL	1	6	0	1	8
2007					
Residential - New	0	3	1	0	4
Residential - Add/Alter	1	4	4	1	10
Commercial - New	0	1	0	0	1
Commercial - Add/Alter	0	1	2	0	3
TOTAL	1	9	7	1	18
2008					
Residential - New	0	0	2	0	2
Residential - Add/Alter	1	1	0	1	3
Commercial - New	0	0	0	0	0
Commercial - Add/Alter	0	1	1	0	2
TOTAL	1	2	3	1	7
2009					Year to Date
Residential - New	0	1			1
Residential - Add/Alter	0	3			3
Commercial - New	0	0			0
Commercial - Add/Alter	0	0			0
TOTAL	0	4	0	0	4

Table 4.33

SEWARD

Seward Sales

Seward Second Quarter GROSS Sales by Line of Business - 2004-2009 - in \$								
LOB	2004	2005	2006	2007	2008	2009	Annual Percent Change	Annual Amount Change
PROD	148,335	188,568	37,294	206,400	67,898	0	-100.0%	-67,898
SALES	10,865,084	11,976,160	12,422,602	13,874,768	15,516,923	15,714,753	1.3%	197,830
CONST	4,519,814	16,685,949	7,478,292	6,477,205	6,905,263	8,069,299	16.9%	1,164,036
PROP	1,826,503	2,249,589	2,181,452	1,815,253	1,986,945	1,798,006	-9.5%	-188,939
TOUR	5,523,170	5,877,386	10,311,894	13,340,879	12,040,452	8,343,331	-30.7%	-3,697,121
SERV	2,879,334	2,354,164	2,379,726	3,621,474	2,948,372	2,684,658	-8.9%	-263,714
PROF	521,631	616,040	917,531	752,534	1,217,305	2,741,439	125.2%	1,524,134
UTIL	705,108	792,413	964,113	1,124,674	1,085,357	1,434,611	32.2%	349,254
MANU	2,782,777	3,455,547	3,279,075	6,155,744	5,348,136	3,947,603	-26.2%	-1,400,533
TRAN	6,127,450	6,919,543	2,831,273	1,387,802	1,528,172	1,477,108	-3.3%	-51,064
WHLS	5,506,656	5,960,258	6,886,194	6,298,639	9,597,038	5,517,836	-42.5%	-4,079,202
GOV	1,343,410	1,391,654	1,447,992	1,553,483	1,572,535	1,667,375	6.0%	94,840
TOTAL	42,749,272	58,467,271	51,137,438	56,608,855	59,814,396	53,396,019	-10.7%	-6,418,377

Table 5.1

For complete listing of Lines of Business, see page 17

Seward Second Quarter GROSS Sales History	
2004	42,749,272
2005	58,467,271
2006	51,137,438
2007	56,608,855
2008	59,814,396
2009	53,396,019

Table 5.2

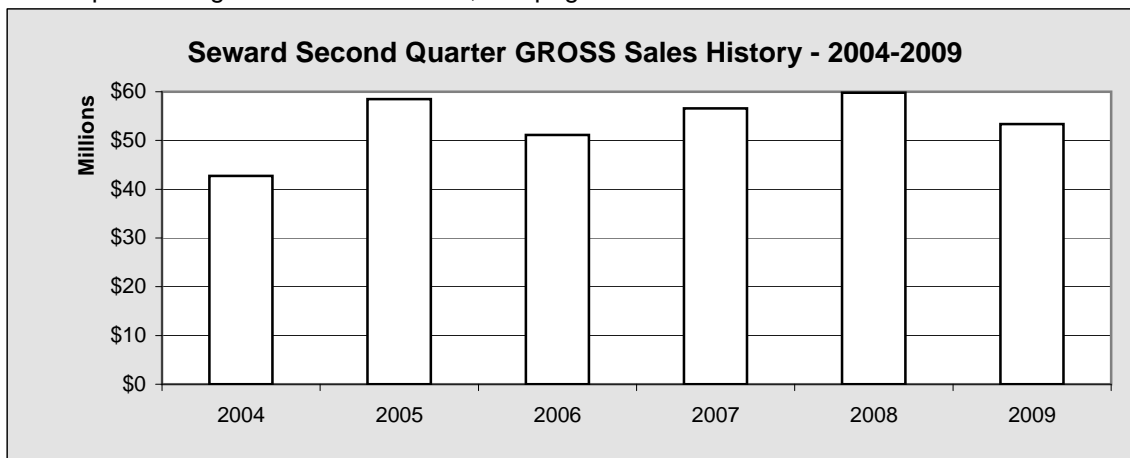

Chart 5.1

Seward Five Year Change Second Quarter GROSS Sales		
LOB	2004	2009
PROD	148,335	0
SALES	10,865,084	15,714,753
CONST	4,519,814	8,069,299
PROP	1,826,503	1,798,006
TOUR	5,523,170	8,343,331
SERV	2,879,334	2,684,658
PROF	521,631	2,741,439
UTIL	705,108	1,434,611
MANU	2,782,777	3,947,603
TRAN	6,127,450	1,477,108
WHLS	5,506,656	5,517,836
GOV	1,343,410	1,667,375
TOTAL	42,749,272	53,396,019

Table 5.3

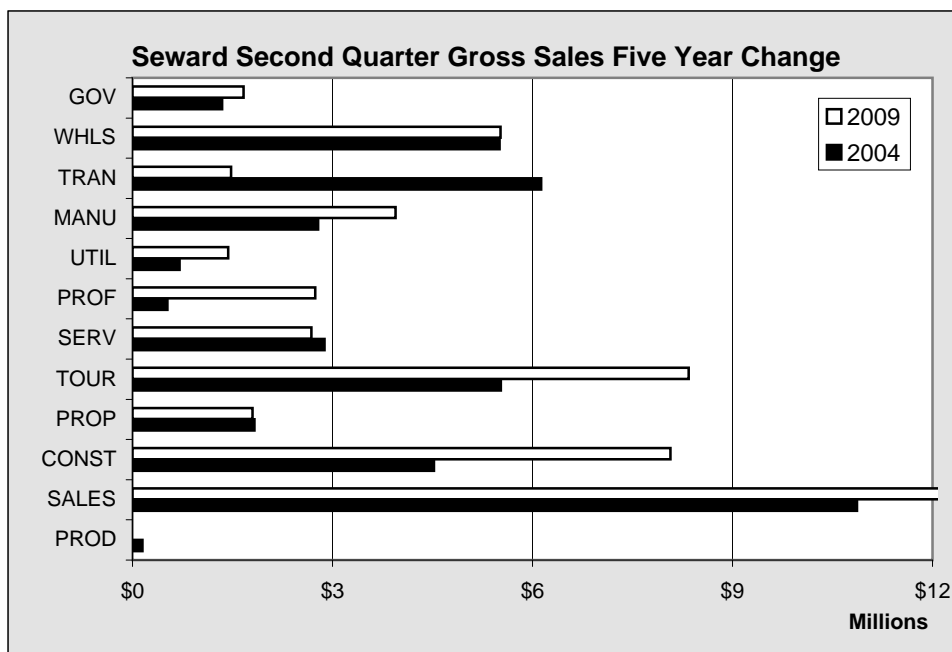

Chart 5.2

Seward Sales

Seward Second Quarter TAXABLE Sales by Line of Business - 2004-2009 - in \$								
LOB	2004	2005	2006	2007	2008	2009	Annual Percent Change	Annual Amount Change
PROD	9,772	6,943	9,759	20,107	0	0	N/A	0
SALES	8,435,895	9,813,123	10,499,840	11,649,390	13,360,057	13,442,582	0.6%	82,525
CONST	178,377	195,772	195,664	170,996	165,643	166,865	0.7%	1,222
PROP	547,794	592,354	515,947	678,891	700,751	706,418	0.8%	5,667
TOUR	5,202,233	5,330,324	9,798,211	10,899,854	10,843,147	7,435,728	-31.4%	-3,407,419
SERV	1,315,780	1,266,326	1,334,305	1,749,869	1,468,793	1,273,866	-13.3%	-194,927
PROF	176,732	181,998	211,249	194,164	169,106	227,073	34.3%	57,967
UTIL	417	838	3,413	2,436	1,089	2,211	103.0%	1,122
MANU	294,416	327,422	320,784	335,739	353,311	320,007	-9.4%	-33,304
TRAN	4,240,599	4,826,957	872,620	1,586,102	69,036	63,768	-7.6%	-5,268
WHLS	1,246,478	1,433,898	1,386,431	1,399,512	1,490,931	1,134,765	-23.9%	-356,166
GOV	1,343,410	1,391,654	1,447,992	1,553,483	1,572,535	1,667,375	6.0%	94,840
TOTAL	22,991,903	25,367,609	26,596,215	30,240,543	30,194,399	26,440,658	-12.4%	-3,753,741

Table 5.4 For complete listing of Lines of Business, see page 17

Seward Second Quarter TAXABLE Sales History	
2004	22,991,903
2005	25,367,609
2006	26,596,215
2007	30,240,543
2008	30,194,399
2009	26,440,658

Table 5.5

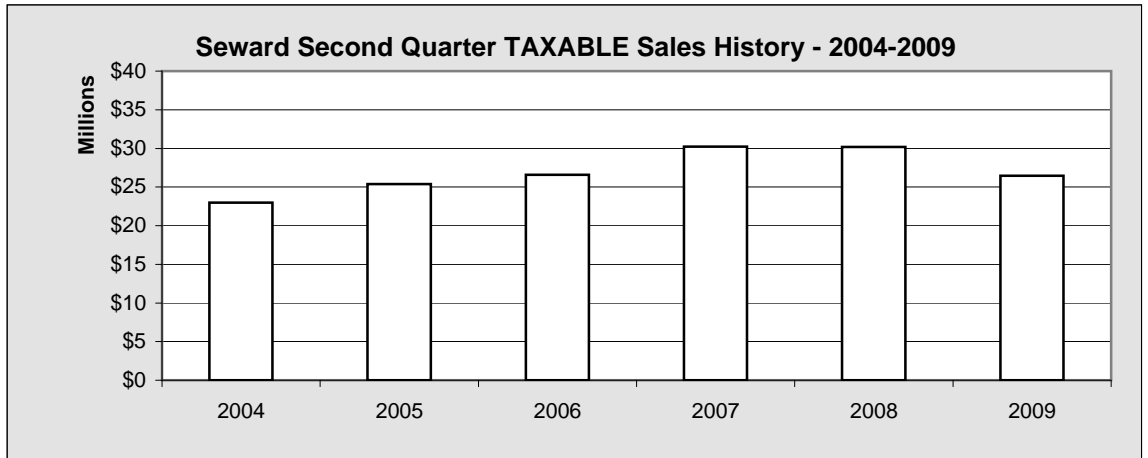

Chart 5.3

Seward Five Year Change Second Quarter TAXABLE Sales		
LOB	2004	2009
PROD	9,772	0
SALES	8,435,895	13,442,582
CONST	178,377	166,865
PROP	547,794	706,418
TOUR	5,202,233	7,435,728
SERV	1,315,780	1,273,866
PROF	176,732	227,073
UTIL	417	2,211
MANU	294,416	320,007
TRAN	4,240,599	63,768
WHLS	1,246,478	1,134,765
GOV	1,343,410	1,667,375
TOTAL	22,991,903	26,440,658

Table 5.6

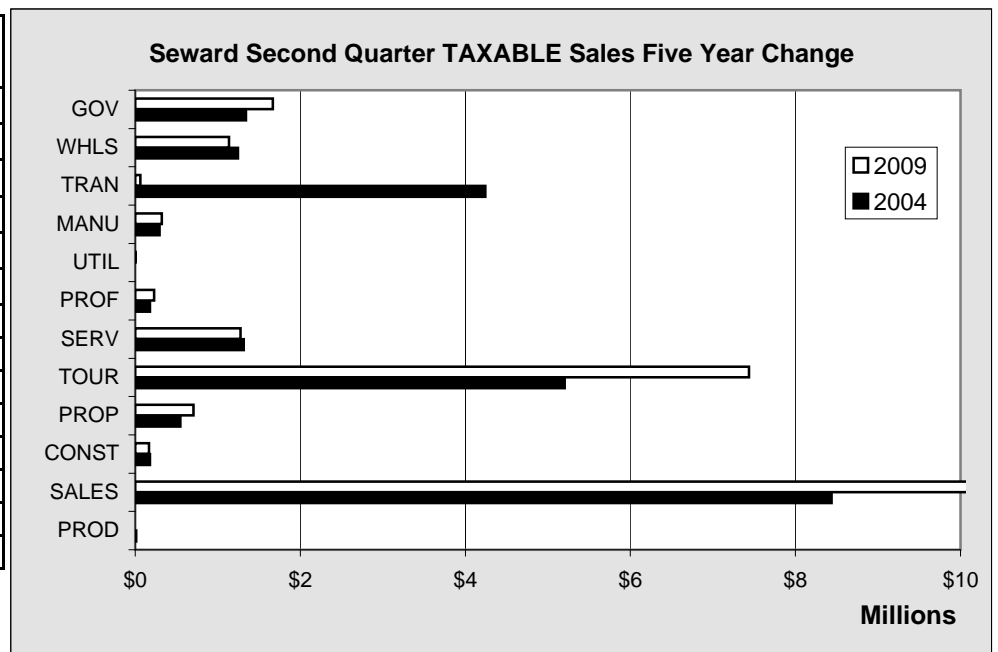

Chart 5.4

Seward Sales

Seward YTD June 30 GROSS Sales by Line of Business - 2004-2009 - in \$								
LOB	2004	2005	2006	2007	2008	2009	Annual Percent Change	Annual Amount Change
PROD	225,532	258,342	75,310	718,545	190,397	0	-100.0%	-190,397
SALES	16,473,675	17,995,081	18,956,842	21,252,085	7,544,394	23,069,946	205.8%	15,525,552
CONST	7,697,150	24,449,274	9,259,809	10,278,562	2,954,760	15,677,982	430.6%	12,723,222
PROP	3,394,012	3,534,969	3,930,878	3,107,190	1,336,293	2,719,380	103.5%	1,383,087
TOUR	7,191,488	7,543,061	11,775,863	13,198,450	1,690,600	9,204,974	444.5%	7,514,374
SERV	4,763,474	3,978,507	4,023,792	5,810,699	2,017,804	4,456,868	120.9%	2,439,064
PROF	817,709	1,197,312	1,841,637	1,327,063	1,087,629	4,316,390	296.9%	3,228,761
UTIL	1,369,505	1,555,972	1,715,859	2,287,677	1,081,208	2,894,625	167.7%	1,813,417
MANU	4,008,997	4,950,428	4,410,957	7,440,508	2,285,652	5,926,911	159.3%	3,641,259
TRAN	7,095,950	8,164,358	3,220,594	3,457,913	405,303	1,956,293	382.7%	1,550,990
WHLS	8,422,176	8,673,600	10,881,020	10,577,849	4,356,490	8,397,520	92.8%	4,041,030
GOV	2,482,893	2,635,200	2,745,819	2,956,949	1,221,955	2,983,454	144.2%	1,761,499
TOTAL	63,942,561	84,936,104	72,838,380	82,413,490	26,172,485	81,604,343	211.8%	55,431,858

Table 5.7

For complete listing of Lines of Business, see page 17

Seward YTD June 30 GROSS Sales History	
2004	63,942,561
2005	84,936,104
2006	72,838,380
2007	82,413,490
2008	26,172,485
2009	81,604,343

Table 5.8

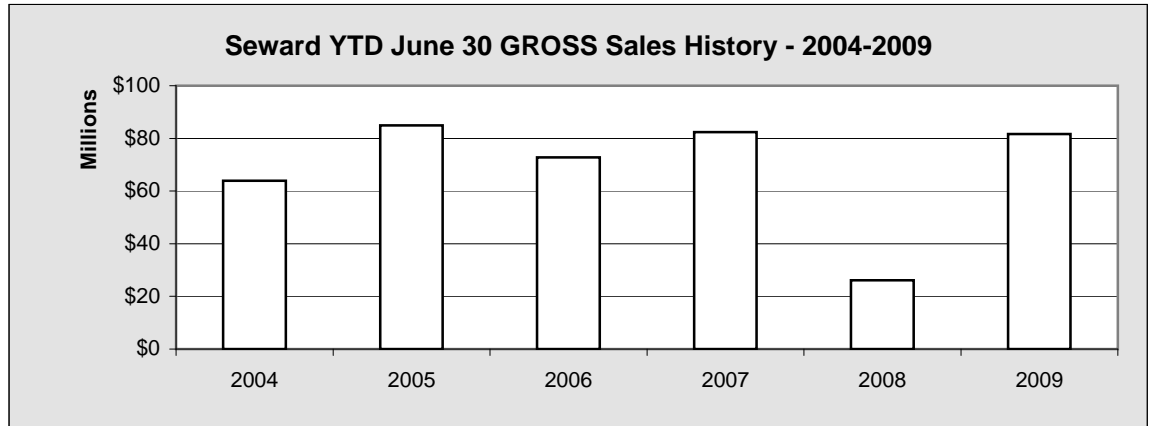

Chart 5.5

Seward Five Year Change YTD June 30 GROSS Sales		
	2004	2009
PROD	225,532	0
SALES	16,473,675	23,069,946
CONST	7,697,150	15,677,982
PROP	3,394,012	2,719,380
TOUR	7,191,488	9,204,974
SERV	4,763,474	4,456,868
PROF	817,709	4,316,390
UTIL	1,369,505	2,894,625
MANU	4,008,997	5,926,911
TRAN	7,095,950	1,956,293
WHLS	8,422,176	8,397,520
GOV	2,482,893	2,983,454
TOTAL	63,942,561	81,604,343

Table 5.9

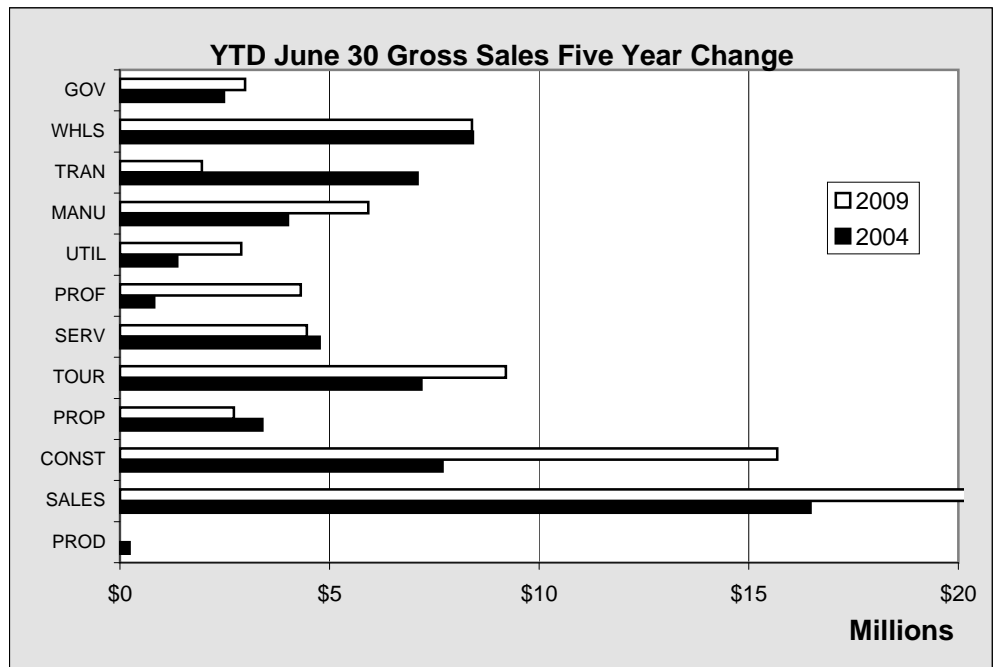

Chart 5.6

Seward Sales

Seward YTD June 30 TAXABLE Sales by Line of Business - 2004-2009 - in \$								
LOB	2004	2005	2006	2007	2008	2009	Annual Percent Change	Annual Amount Change
PROD	20,860	14,654	22,152	30,569	4,356	0	-100.0%	-4,356
SALES	12,839,820	14,627,627	15,617,400	17,108,823	5,918,799	19,317,562	226.4%	13,398,763
CONST	334,054	344,167	334,173	299,863	126,666	295,680	133.4%	169,014
PROP	919,519	960,451	862,047	1,057,241	381,583	1,105,866	189.8%	724,283
TOUR	6,716,694	6,819,183	11,117,785	12,273,527	1,331,288	8,095,464	508.1%	6,764,176
SERV	2,211,916	2,098,361	2,240,858	2,714,476	1,141,279	2,205,578	93.3%	1,064,299
PROF	260,714	278,033	295,265	286,286	85,710	328,058	282.8%	242,348
UTIL	1,761	1,751	5,188	5,064	1,237	3,937	218.3%	2,700
MANU	398,697	430,573	400,582	415,032	70,288	413,961	488.9%	343,673
TRAN	4,377,968	4,999,009	884,702	1,608,527	18,159	90,179	396.6%	72,020
WHLS	1,923,115	2,249,585	2,240,642	2,353,883	1,027,859	1,937,034	88.5%	909,175
GOV	2,482,893	2,635,200	2,745,819	2,956,949	1,221,955	2,983,454	144.2%	1,761,499
TOTAL	32,488,011	35,458,594	36,766,613	41,110,240	11,329,179	36,776,773	224.6%	25,447,594

Table 5.10

For complete listing of Lines of Business, see page 17

Seward YTD June 30 TAXABLE Sales History	
2004	32,488,011
2005	35,458,594
2006	36,766,613
2007	41,110,240
2008	11,329,179
2009	36,776,773

Table 5.11

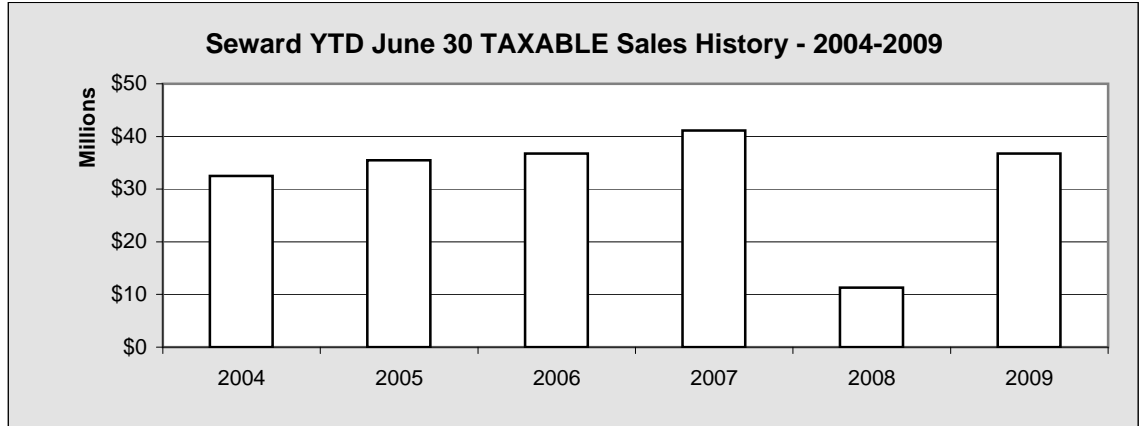

Chart 5.7

Seward Five Year Change YTD June 30 TAXABLE Sales		
	2004	2009
PROD	20,860	0
SALES	12,839,820	19,317,562
CONST	334,054	295,680
PROP	919,519	1,105,866
TOUR	6,716,694	8,095,464
SERV	2,211,916	2,205,578
PROF	260,714	328,058
UTIL	1,761	3,937
MANU	398,697	413,961
TRAN	4,377,968	90,179
WHLS	1,923,115	1,937,034
GOV	2,482,893	2,983,454
TOTAL	32,488,011	36,776,773

Table 5.12

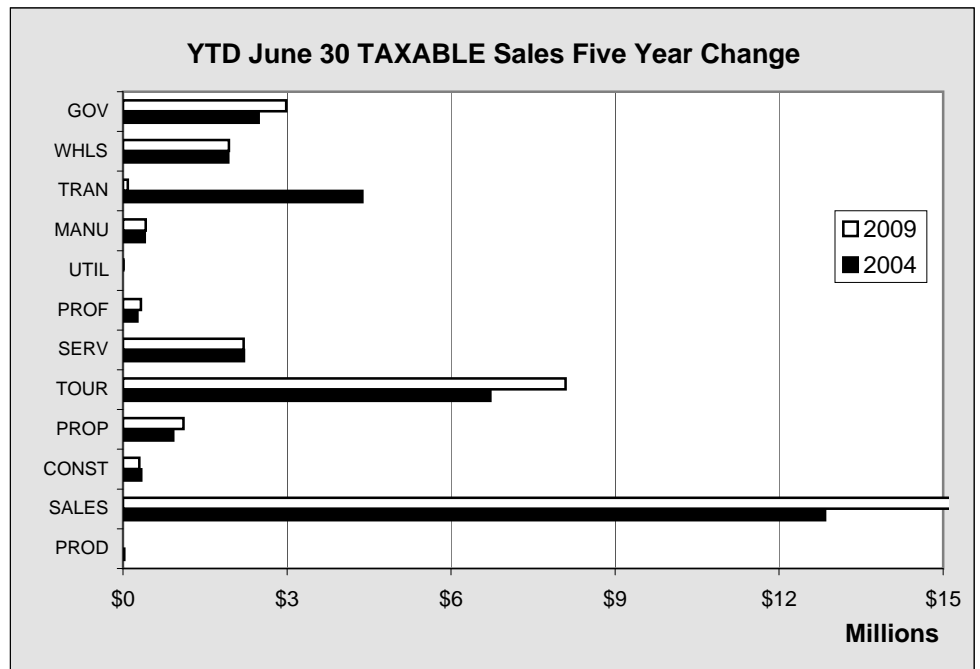

Chart 5.8

Seward Sales

Seward Annual GROSS Sales by Line of Business - 2003-2008 - in \$

LOB	2003	2004	2005	2006	2007	2008	Annual Percent Change	Annual Amount Change
PROD	471,217	228,403	227,768	49,738	327,692	105,425	-67.8%	-222,267
SALES	34,477,471	36,812,924	42,226,370	44,401,192	49,619,690	55,699,276	12.3%	6,079,586
CONST	26,480,094	30,132,289	39,812,044	39,567,262	20,691,970	30,696,120	48.3%	10,004,150
PROP	10,726,937	8,402,843	8,536,636	8,267,710	7,768,625	7,889,016	1.5%	120,391
TOUR	17,220,986	36,285,102	38,643,753	39,474,443	43,173,582	39,168,283	-9.3%	-4,005,299
SERV	9,153,785	9,192,098	8,372,277	8,780,572	11,559,163	10,024,393	-13.3%	-1,534,770
PROF	3,099,221	3,533,910	3,890,494	4,824,944	4,041,647	6,058,799	49.9%	2,017,152
UTIL	2,572,129	2,072,046	3,313,549	4,001,907	4,411,620	4,789,813	8.6%	378,193
MANU	13,428,447	10,505,152	13,089,654	10,825,783	17,919,182	17,453,128	-2.6%	-466,054
TRAN	20,573,537	4,648,661	4,645,626	4,346,626	4,975,690	5,720,557	15.0%	744,867
WHLS	13,481,110	18,672,628	20,448,645	27,657,738	24,220,285	30,168,944	24.6%	5,948,659
GOV	5,277,002	5,530,886	5,898,177	6,159,339	6,539,108	6,801,021	4.0%	261,913
TOTAL	156,961,936	166,016,942	189,104,993	198,357,254	195,248,254	214,574,775	9.9%	19,326,521

Table 5.13

For complete listing of Lines of Business, see page 17

Seward Annual GROSS Sales History	
2003	156,961,936
2004	166,016,942
2005	189,104,993
2006	198,357,254
2007	195,248,254
2008	214,574,775

Table 5.14

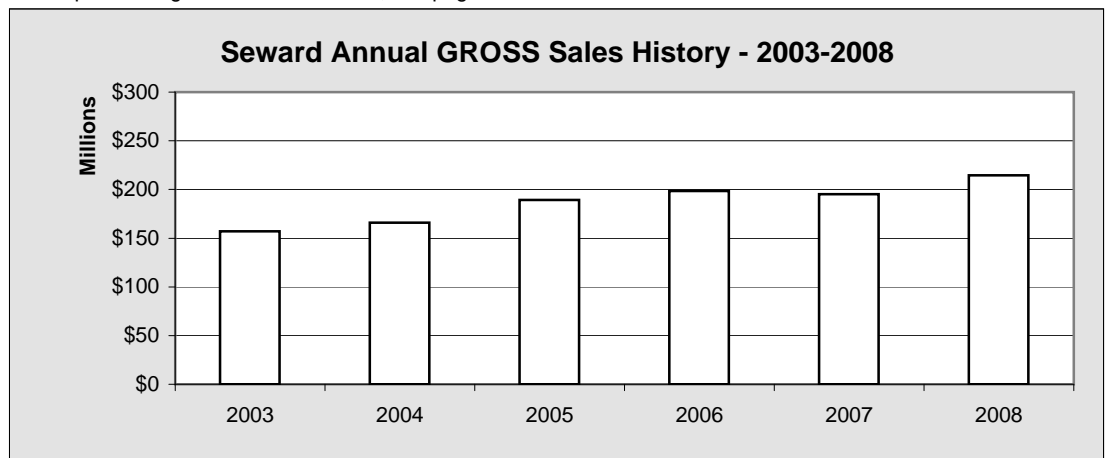

Chart 5.9

Five Year Change Annual GROSS Sales		
LOB	2003	2008
PROD	471,217	105,425
SALES	34,477,471	55,699,276
CONST	26,480,094	30,696,120
PROP	10,726,937	7,889,016
TOUR	17,220,986	39,168,283
SERV	9,153,785	10,024,393
PROF	3,099,221	6,058,799
UTIL	2,572,129	4,789,813
MANU	13,428,447	17,453,128
TRAN	20,573,537	5,720,557
WHLS	13,481,110	30,168,944
GOV	5,277,002	6,801,021
TOTAL	156,961,936	214,574,775

Table 5.15

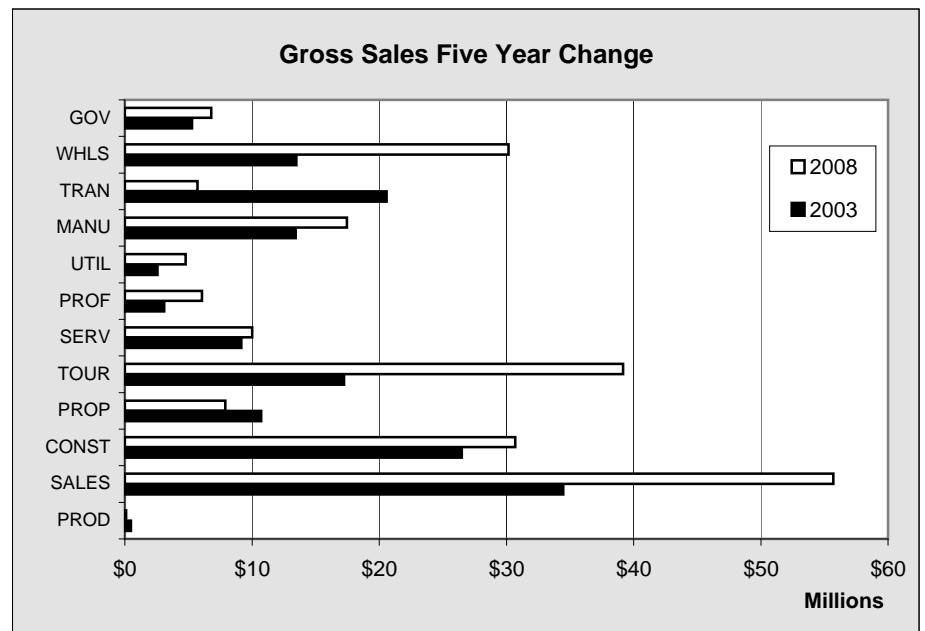

Chart 5.10

Seward Sales

Seward Annual TAXABLE Sales by Line of Business - 2003-2008 - in \$								
LOB	2003	2004	2005	2006	2007	2008	Annual Percent Change	Annual Amount Change
PROD	47,923	0	0	1,024	500	113	-77.4%	-387
SALES	28,161,941	29,812,800	34,557,054	36,549,236	40,808,140	47,295,682	15.9%	6,487,542
CONST	647,537	693,308	685,553	697,846	621,401	615,140	-1.0%	-6,261
PROP	2,432,971	2,054,719	2,109,278	2,094,443	2,426,692	2,648,265	9.1%	221,573
TOUR	16,487,073	30,595,843	32,615,913	32,711,217	38,893,264	34,735,735	-10.7%	-4,157,529
SERV	4,232,905	4,555,875	4,489,632	4,770,338	5,625,187	5,363,162	-4.7%	-262,025
PROF	700,567	643,915	643,442	672,854	710,350	644,427	-9.3%	-65,923
UTIL	5,583	1,261	3,979	8,183	8,595	5,595	-34.9%	-3,000
MANU	954,975	1,043,346	954,243	979,243	1,046,510	1,007,740	-3.7%	-38,770
TRAN	13,270,848	218,804	398,174	265,138	182,812	192,933	5.5%	10,121
WHLS	4,134,748	4,680,451	5,457,638	5,253,373	5,465,167	5,767,956	5.5%	302,789
GOV	5,271,662	5,466,886	5,834,097	6,087,059	6,467,108	6,727,021	4.0%	259,913
TOTAL	76,348,733	79,767,208	87,749,003	90,089,954	102,255,726	105,003,769	2.7%	2,748,043

Table 5.16

For complete listing of Lines of Business, see page 17

Seward Annual TAXABLE Sales History	
2003	76,348,733
2004	79,767,208
2005	87,749,003
2006	90,089,954
2007	102,255,726
2008	105,003,769

Table 5.17

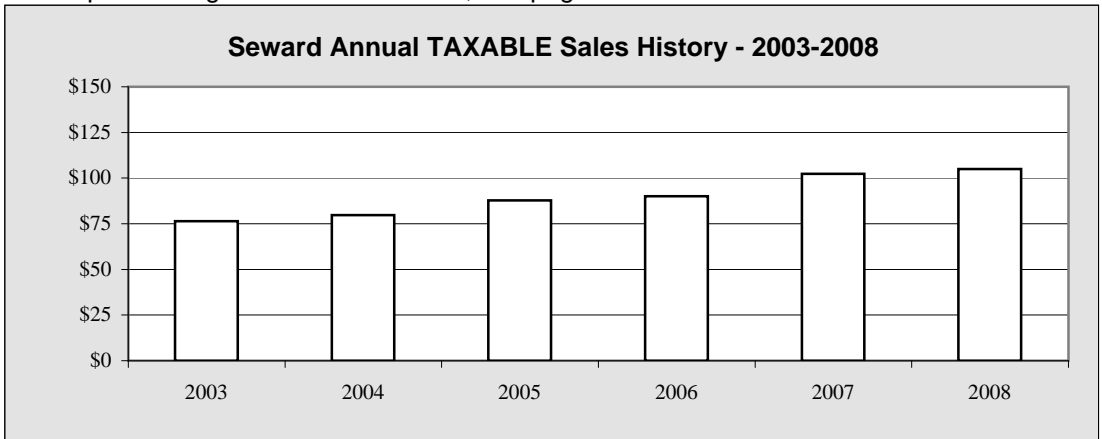

Chart 5.11

Five Year Change Annual TAXABLE Sales		
LOB	2003	2008
PROD	47,923	113
SALES	28,161,941	47,295,682
CONST	647,537	615,140
PROP	2,432,971	2,648,265
TOUR	16,487,073	34,735,735
SERV	4,232,905	5,363,162
PROF	700,567	644,427
UTIL	5,583	5,595
MANU	954,975	1,007,740
TRAN	13,270,848	192,933
WHLS	4,134,748	5,767,956
GOV	5,271,662	6,727,021
TOTAL	76,348,733	105,003,769

Table 5.18

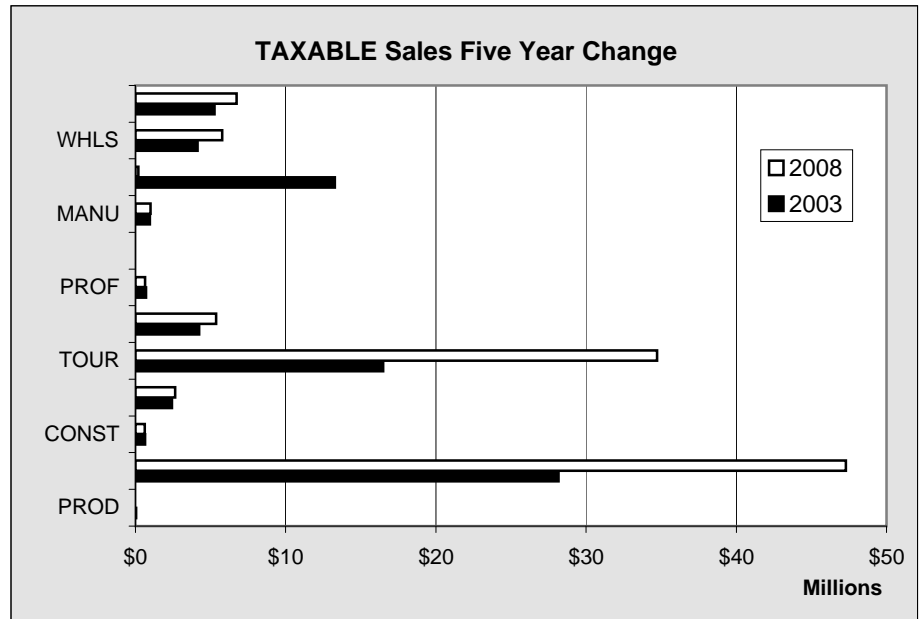

Chart 5.12

Seward Sales

Seward GROSS Sales by Line of Business by Quarter - 2008 in \$

	1st Quarter	2nd Quarter	3rd Quarter	4th Quarter	Total
Resource Production	37,527	67,898	0	0	105,425
Sales	8,364,730	15,516,923	22,919,312	8,898,311	55,699,276
Construction	3,193,803	6,905,263	7,937,529	12,659,525	30,696,120
Property	1,380,136	1,986,945	2,487,064	2,034,871	7,889,016
Tourism	1,033,658	12,040,452	24,420,763	1,673,410	39,168,283
Services	1,960,925	2,948,372	3,273,376	1,841,720	10,024,393
Professional	1,156,667	1,217,305	1,820,318	1,864,509	6,058,799
Utility	1,081,208	1,085,357	1,361,903	1,261,345	4,789,813
Manufacturing	2,309,720	5,348,136	8,054,623	1,740,649	17,453,128
Transportation & Warehousing	409,250	1,528,172	3,259,292	523,843	5,720,557
Wholesale	4,356,490	9,597,038	12,019,680	4,195,736	30,168,944
Government	1,221,955	1,572,535	1,891,905	2,114,626	6,801,021
TOTAL	26,506,069	59,814,396	89,445,765	38,808,545	214,574,775

Table 5.19

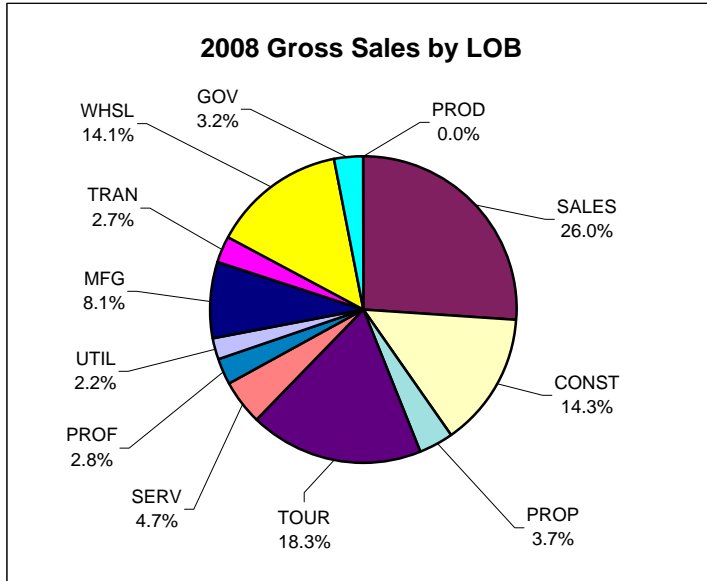

Chart 5.13

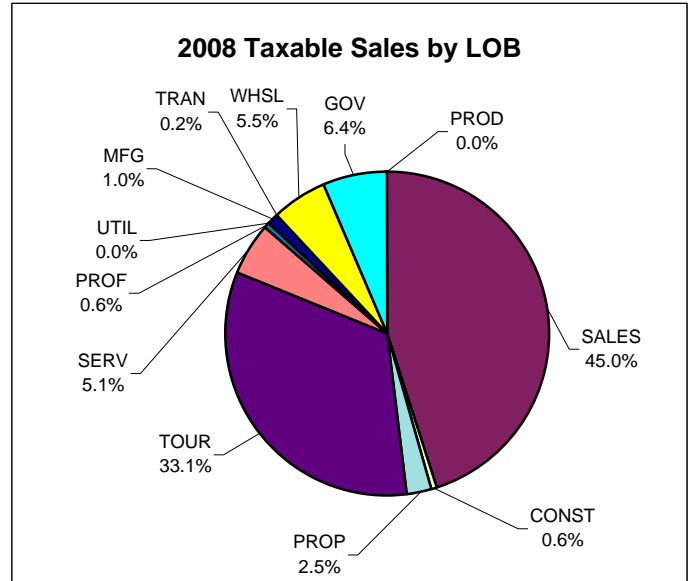

Chart 5.14

Seward TAXABLE Sales by Line of Business by Quarter - 2008- in \$

LOB	1st Quarter	2nd Quarter	3rd Quarter	4th Quarter	Total
Resource Production	113	0	0	0	113
Sales	6,526,015	13,360,057	20,081,353	7,328,257	47,295,682
Construction	135,194	165,643	145,536	168,767	615,140
Property	408,100	700,751	1,032,797	506,617	2,648,265
Tourism	734,363	10,843,147	22,374,849	783,376	34,735,735
Services	1,096,653	1,468,793	1,700,552	1,097,164	5,363,162
Professional	96,211	169,106	245,260	133,850	644,427
Utility	1,237	1,089	2,169	1,100	5,595
Manufacturing	75,080	353,311	437,879	141,470	1,007,740
Transportation & Warehousing	16,873	69,036	90,574	16,450	192,933
Wholesale	1,027,859	1,490,931	2,386,481	862,685	5,767,956
Government	1,221,955	1,572,535	1,891,905	2,040,626	6,727,021
TOTAL	11,339,653	30,194,399	50,389,355	13,080,362	105,003,769

Table 5.20

Seward Sales

Seward GROSS Sales by Line of Business by Quarter - 2007- in \$					
LOB	1st Quarter	2nd Quarter	3rd Quarter	4th Quarter	Total
Resource Production	45,858	206,400	53,103	22,331	327,692
Sales	7,377,317	13,874,768	20,330,405	8,037,200	49,619,690
Construction	3,870,279	6,477,205	3,244,299	7,100,187	20,691,970
Property	1,291,921	1,815,253	2,749,928	1,911,523	7,768,625
Tourism	1,599,015	13,340,879	25,976,639	2,257,049	43,173,582
Services	2,086,448	3,621,474	3,718,404	2,132,837	11,559,163
Professional	574,529	752,534	976,489	1,738,095	4,041,647
Utility	1,163,003	1,124,674	1,070,111	1,053,832	4,411,620
Manufacturing	1,677,929	6,155,744	7,200,311	2,885,198	17,919,182
Transporation & Warehousing	239,160	1,387,802	2,540,974	807,754	4,975,690
Wholesale	4,279,210	6,298,639	8,872,729	4,769,707	24,220,285
Government	1,403,466	1,553,483	1,649,505	1,932,654	6,539,108
TOTAL	25,608,135	56,608,855	78,382,897	34,648,367	195,248,254

Table 5.21

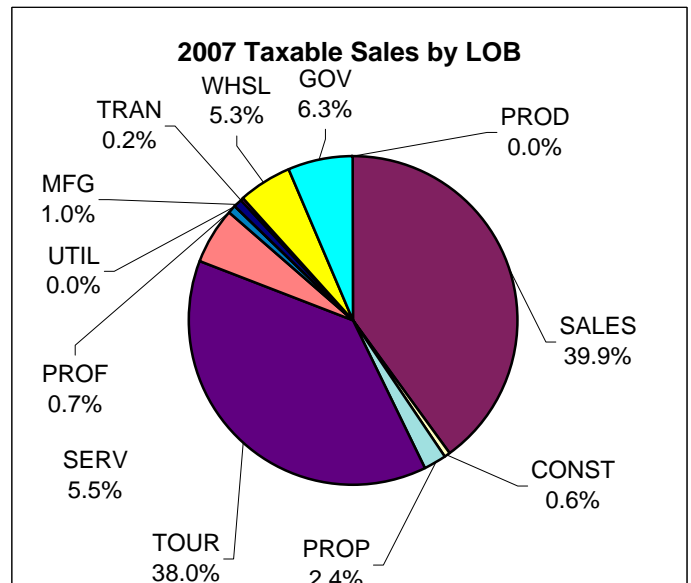
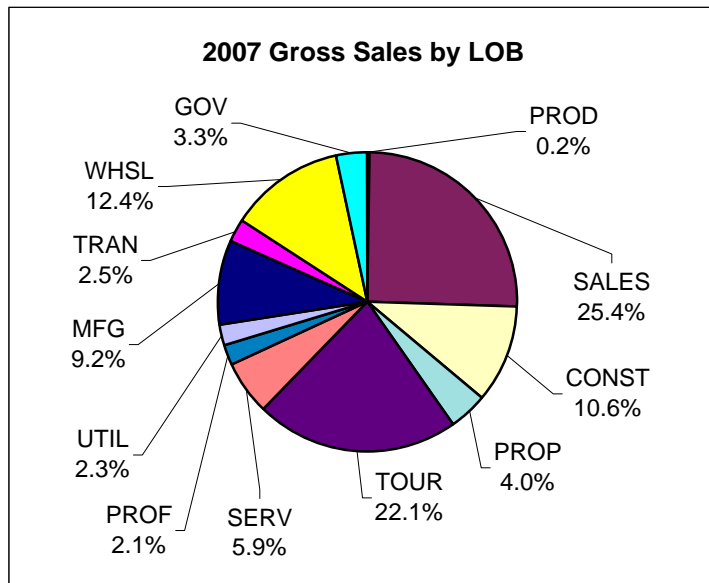

Chart 5.15

Chart 5.16

Seward TAXABLE Sales by Line of Business by Quarter - 2007 - in \$					
LOB	1st Quarter	2nd Quarter	3rd Quarter	4th Quarter	Total
Resource Production	0	500	0	0	500
Sales	5,459,433	11,649,440	17,213,707	6,485,560	40,808,140
Construction	136,277	179,192	145,599	160,333	621,401
Property	379,647	680,497	881,813	484,735	2,426,692
Tourism	1,376,173	12,342,081	23,833,459	1,341,551	38,893,264
Services	952,797	1,639,086	1,840,702	1,192,602	5,625,187
Professional	102,636	200,548	258,874	148,292	710,350
Utility	2,628	2,436	2,280	1,251	8,595
Manufacturing	82,345	339,519	496,203	128,443	1,046,510
Transporation & Warehousing	20,125	54,168	75,344	33,175	182,812
Wholesale	954,371	1,399,512	2,264,390	846,894	5,465,167
Government	1,403,466	1,553,483	1,649,505	1,860,654	6,467,108
TOTAL	10,869,898	30,040,462	48,661,876	12,683,490	102,255,726

Table 5.22

Seward Sales

Seward GROSS Sales by Line of Business by Quarter - 2006 - in \$					
LOB	1st Quarter	2nd Quarter	3rd Quarter	4th Quarter	Total
Resource Production	78	946	0	48,714	49,738
Sales	6,534,504	12,422,602	17,874,031	7,570,055	44,401,192
Construction	1,811,963	7,490,563	9,617,755	20,646,981	39,567,262
Property	1,749,426	2,181,452	2,256,711	2,080,121	8,267,710
Tourism	1,509,869	11,911,893	23,853,680	2,199,001	39,474,443
Services	1,644,851	2,380,422	2,767,202	1,988,097	8,780,572
Professional	924,106	917,531	1,155,139	1,828,168	4,824,944
Utility	751,746	964,113	1,230,113	1,055,935	4,001,907
Manufacturing	1,139,374	3,303,152	4,230,878	2,152,379	10,825,783
Transportation & Warehousing	342,636	1,185,855	2,286,927	531,208	4,346,626
Wholesale	3,994,826	6,886,194	8,673,074	8,103,644	27,657,738
Government	1,297,827	1,447,992	1,647,369	1,766,151	6,159,339
TOTAL	21,701,206	51,092,715	75,592,879	49,970,454	198,357,254

Table 5.23

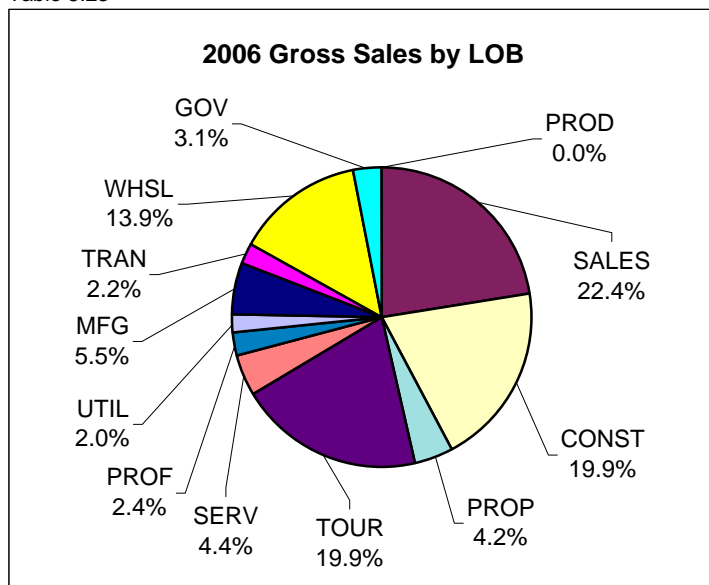

Chart 5.17

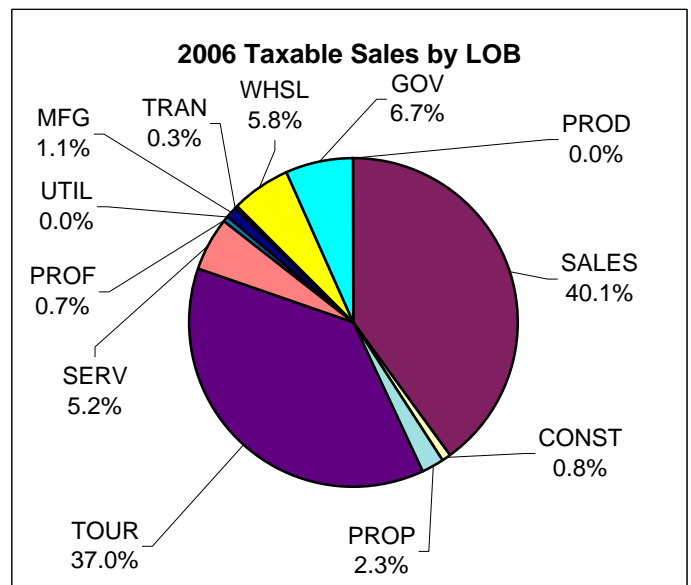

Chart 5.18

Seward TAXABLE Sales by Line of Business by Quarter - 2006 - in \$					
LOB	1st Quarter	2nd Quarter	3rd Quarter	4th Quarter	Total
Resource Production	78	946	0	0	1,024
Sales	5,117,824	10,499,840	14,941,849	5,989,723	36,549,236
Construction	147,435	200,146	165,744	184,521	697,846
Property	348,743	518,383	752,424	474,893	2,094,443
Tourism	1,321,074	10,552,821	20,474,137	1,363,185	33,711,217
Services	879,420	1,325,319	1,444,757	1,120,842	4,770,338
Professional	109,291	218,495	222,174	122,894	672,854
Utility	1,775	3,413	250	2,745	8,183
Manufacturing	83,187	325,115	484,057	86,884	979,243
Transportation & Warehousing	9,797	117,314	103,575	34,452	265,138
Wholesale	854,211	1,386,431	2,201,861	810,870	5,253,373
Government	1,297,827	1,447,992	1,647,369	1,693,871	6,087,059
TOTAL	10,170,662	26,596,215	42,438,197	11,884,880	91,089,954

Table 5.24

Seward Sales

Seward Annual Gross Sales by Quarter - in \$						
	1st Quarter	2nd Quarter	3rd Quarter	4th Quarter	Total	Annual Change
1994	16,634,219	28,820,027	35,815,554	18,605,214	99,875,014	
1995	17,305,724	31,740,326	49,703,768	28,713,985	127,463,803	27.6%
1996	22,782,553	35,228,909	48,116,743	27,720,437	133,848,642	5.0%
1997	23,787,658	38,959,842	54,552,242	28,247,933	145,547,675	8.7%
1998	22,948,971	35,050,219	50,480,063	24,026,995	132,506,248	-9.0%
1999	23,356,887	36,041,325	50,509,645	20,248,664	130,156,521	-1.8%
2000	19,087,797	38,017,519	57,262,889	27,790,366	142,158,571	9.2%
2001	20,537,710	44,452,278	62,874,759	20,503,354	148,368,101	4.4%
2002	22,954,013	40,385,376	56,721,649	22,308,588	142,369,626	-4.0%
2003	20,935,184	46,984,153	61,708,185	27,334,414	156,961,936	10.2%
2004	21,175,289	42,749,272	63,729,559	38,362,822	166,016,942	5.8%
2005	26,472,186	58,409,308	70,009,818	34,213,681	189,104,993	13.9%
2006	21,701,206	51,092,715	75,592,879	49,970,454	198,357,254	4.9%
2007	25,608,135	56,608,855	78,382,897	34,648,367	195,248,254	-1.6%
2008	26,506,069	59,814,396	89,445,765	38,808,545	214,574,775	9.9%
2009	28,208,324	53,396,019			81,604,343	
Change	6.4%	-10.7%	14.1%	12.0%	9.9%	

Table 5.25

Seward Annual Taxable Sales by Quarter - in \$						
	1st Quarter	2nd Quarter	3rd Quarter	4th Quarter	Total	Annual Change
1994	7,525,434	15,434,817	21,557,820	8,741,106	53,259,177	
1995	7,674,012	16,721,303	22,898,202	8,461,870	55,755,387	4.7%
1996	8,027,358	16,410,250	24,077,648	8,681,685	57,196,941	2.6%
1997	8,770,990	16,994,442	26,208,216	10,542,376	62,516,024	9.3%
1998	8,541,911	19,372,356	29,591,398	9,772,599	67,278,264	7.6%
1999	9,218,678	19,907,186	31,789,068	10,557,767	71,472,699	6.2%
2000	9,374,360	21,161,398	32,904,973	10,544,695	73,985,426	3.5%
2001	9,073,993	21,553,264	36,591,833	10,007,501	77,226,591	4.4%
2002	9,051,044	22,176,474	34,338,060	10,025,144	75,590,722	-2.1%
2003	9,284,504	22,072,081	34,702,846	10,289,302	76,348,733	1.0%
2004	9,494,764	22,991,903	36,892,269	10,388,272	79,767,208	4.5%
2005	10,094,338	25,309,646	40,943,244	11,401,775	87,749,003	10.0%
2006	10,170,662	26,596,215	42,438,197	11,884,880	91,089,954	3.8%
2007	10,869,898	30,040,462	48,661,876	12,683,490	102,255,726	12.3%
2008	11,339,653	30,194,399	50,389,355	13,080,362	105,003,769	2.7%
2009	10,336,115	26,440,658			36,776,773	
Change	-8.8%	-12.4%	3.5%	3.1%	2.7%	

Table 5.26

Seward Annual Non-Taxable Sales by Quarter - in \$						
	1st Quarter	2nd Quarter	3rd Quarter	4th Quarter	Total	Annual Change
1994	9,108,785	13,385,210	14,257,734	9,864,108	46,615,837	
1995	9,631,712	15,019,023	26,805,566	20,252,115	71,708,416	53.8%
1996	14,755,195	18,818,659	24,039,095	19,038,752	76,651,701	6.9%
1997	15,016,668	21,965,400	28,344,026	17,705,557	83,031,651	8.3%
1998	14,407,060	15,677,863	20,888,665	14,254,396	65,227,984	-21.4%
1999	14,138,209	16,134,139	18,720,577	9,690,897	58,683,822	-10.0%
2000	9,713,437	16,856,121	24,357,916	17,245,671	68,173,145	16.2%
2001	11,463,717	22,899,014	26,282,926	10,495,853	71,141,510	4.4%
2002	13,902,969	18,208,902	22,383,589	12,283,444	66,778,904	-6.1%
2003	11,650,680	24,912,072	27,005,339	17,045,112	80,613,203	20.7%
2004	11,680,525	19,757,369	26,837,290	27,974,550	86,249,734	7.0%
2005	16,377,848	33,099,662	29,066,574	22,811,906	101,355,990	17.5%
2006	11,530,544	24,496,500	33,154,682	38,085,574	107,267,300	5.8%
2007	14,738,237	26,568,393	29,721,021	21,964,877	92,992,528	-13.3%
2008	15,166,416	29,619,997	39,056,410	25,728,183	109,571,006	17.8%
2009	17,872,209	26,955,361				
Change	17.8%	-9.0%	31.4%	17.1%	17.8%	

Table 5.27

Seward Construction

Seward 2nd Quarter Permit VALUES by Type - 2003-2009 - in \$								
	2003	2004	2005	2006	2007	2008	2009	Annual Change
Residential New	215,000	873,000	388,000	415,000	82,354	1,700,000	200,000	-88.2%
Residential Alter/Add	100,000	144,900	84,220	65,200	13,000	128,964	70,650	-45.2%
Commercial New	3,313,000	5,000,000	271,320	800,000	0	0	9,583,649	NA
Commercial Alter/Add	44,010	1,426,000	15,000	904,472	1,792,933	15,500	1,104,500	7025.8%
Total	3,672,010	7,443,900	758,540	2,184,672	1,888,287	1,844,464	10,958,799	494.1%
Annual Change		102.7%	-89.8%	188.0%	-13.6%	-2.3%	494.1%	

Table 5.28

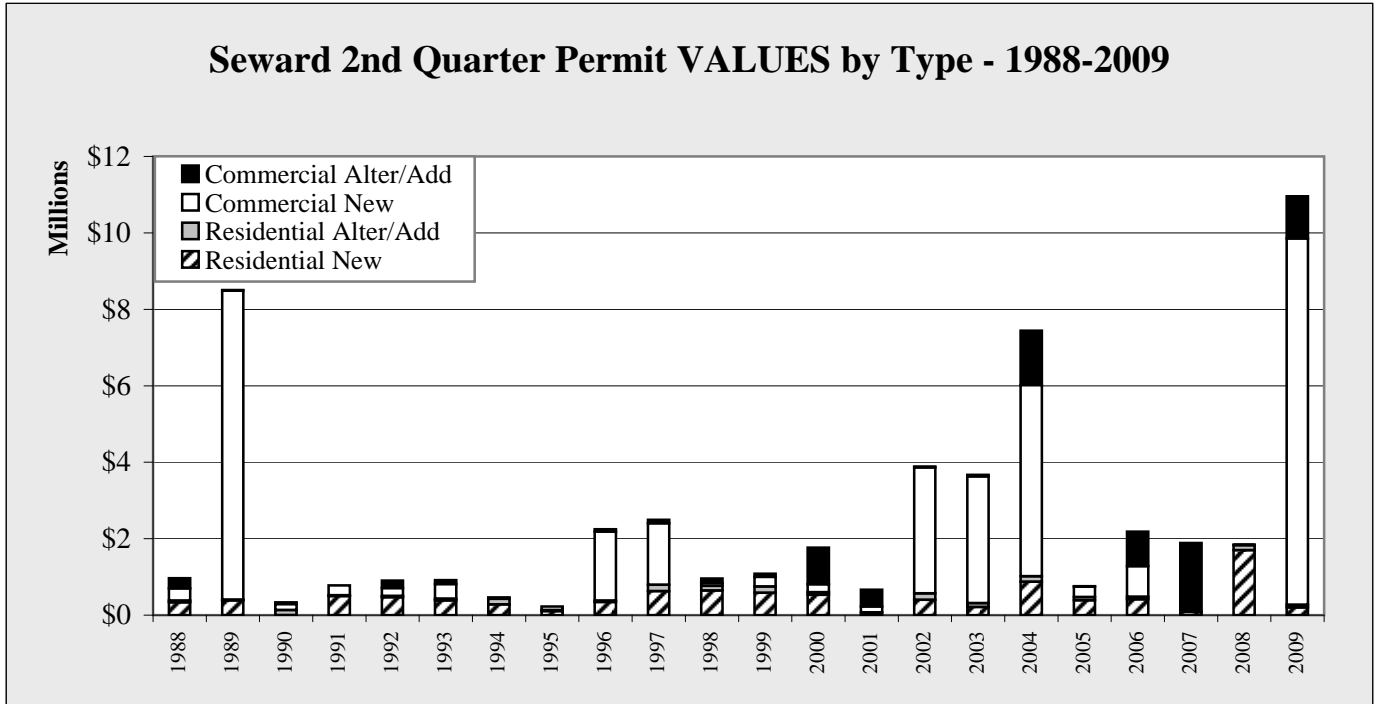

Chart 5.19

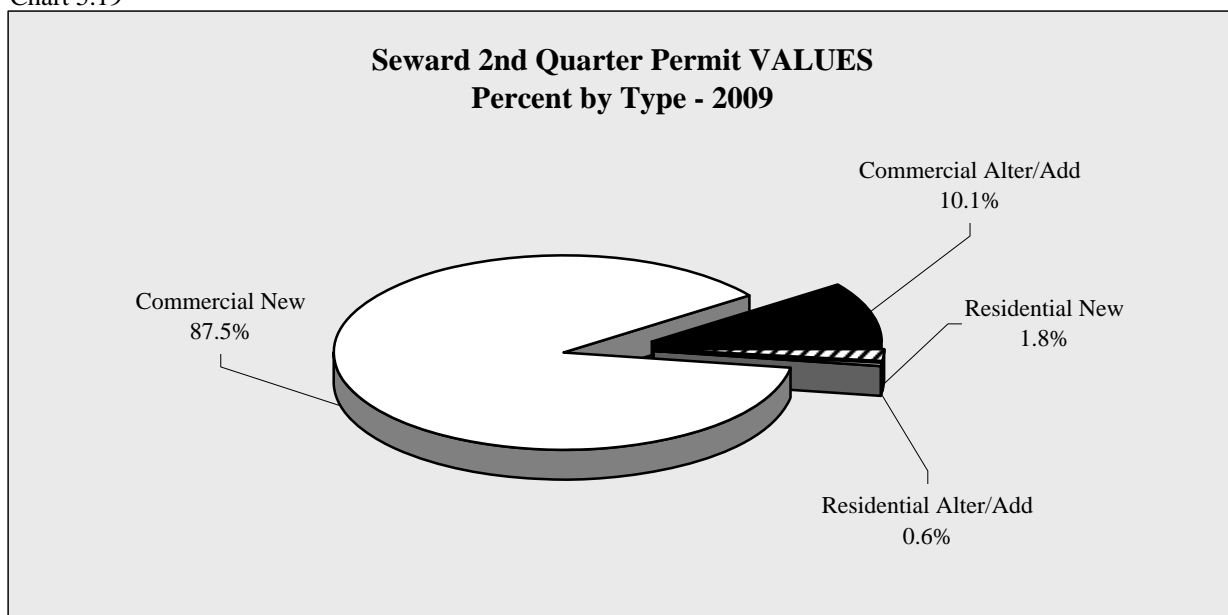

Chart 5.20

Seward Construction

Seward 2nd Quarter Permit VOLUME by Type - 2003-2009								
	2003	2004	2005	2006	2007	2008	2009	Annual Change
Residential New	2	4	3	3	1	3	1	-66.7%
Residential Alter/Add	3	7	9	7	2	7	9	28.6%
Commercial New	4	1	5	11	0	0	5	NA
Commercial Alter/Add	4	9	2	2	8	2	7	250.0%
Total	13	21	19	23	11	12	22	83.3%
Annual Change		61.5%	-9.5%	21.1%	-52.2%	9.1%	83.3%	

Table 5.29

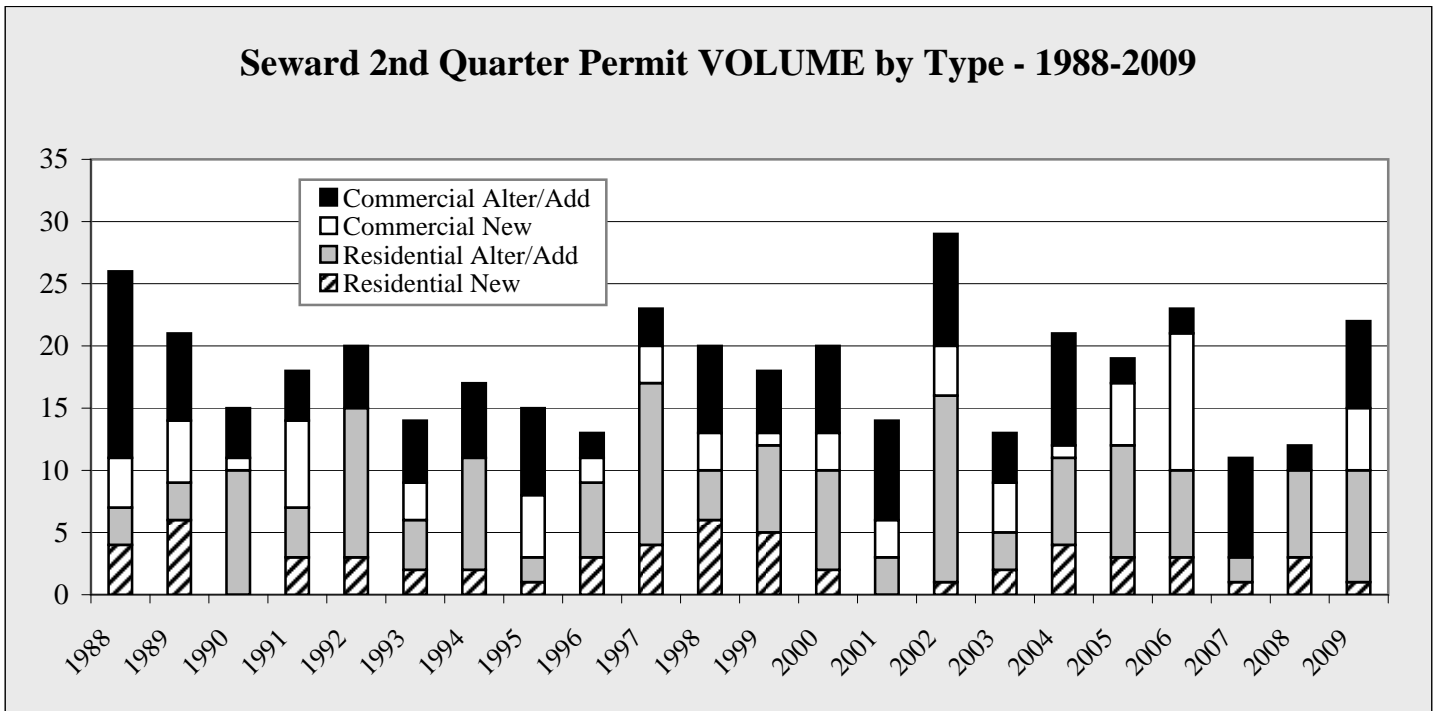

Chart 5.21

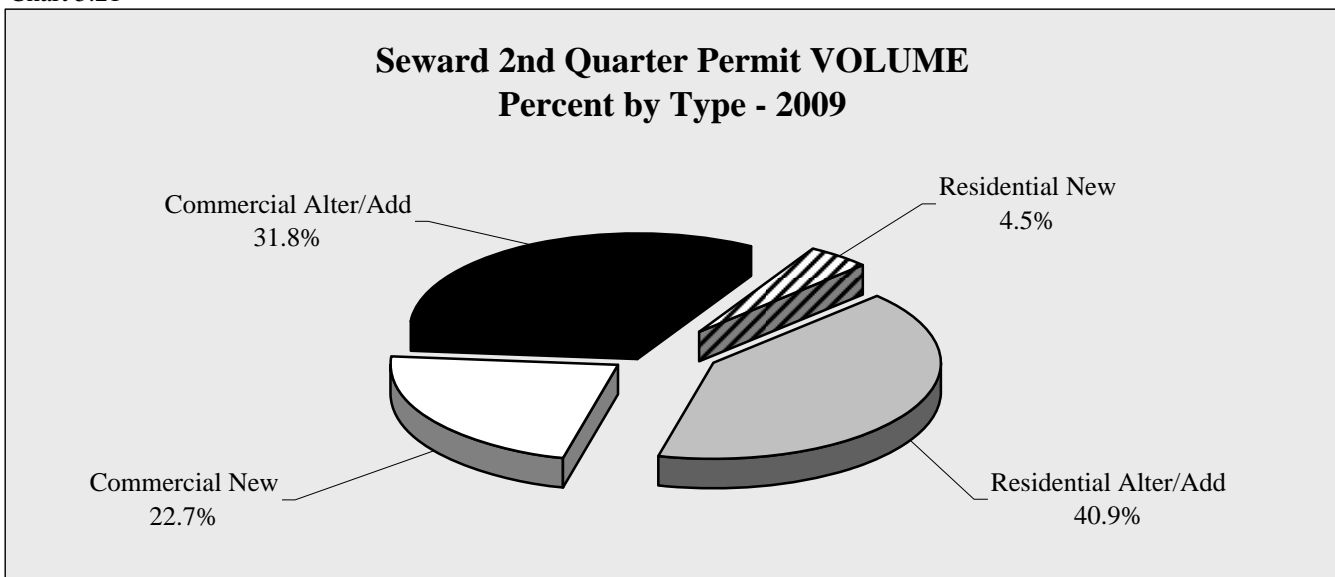

Chart 5.22

Seward Construction

Seward YTD 6/30 Permit VALUES by Type - 2003-2009 - in \$								
	2003	2004	2005	2006	2007	2008	2009	Annual Change
Residential New	333,000	873,000	1,311,000	415,000	82,354	1,700,000	200,000	-88.2%
Residential Alter/Add	157,500	192,900	87,520	66,200	13,000	174,379	80,150	-54.0%
Commercial New	3,385,000	12,500,000	277,320	800,000	208,513	0	9,936,649	NA
Commercial Alter/Add	1,701,865	1,619,600	255,000	1,525,689	2,387,658	379,500	7,369,120	1841.8%
Total	5,577,365	15,185,500	1,930,840	2,806,889	2,691,525	2,253,879	17,585,919	680.3%
Annual Change		172.3%	-87.3%	45.4%	-4.1%	-16.3%	680.3%	

Table 5.30

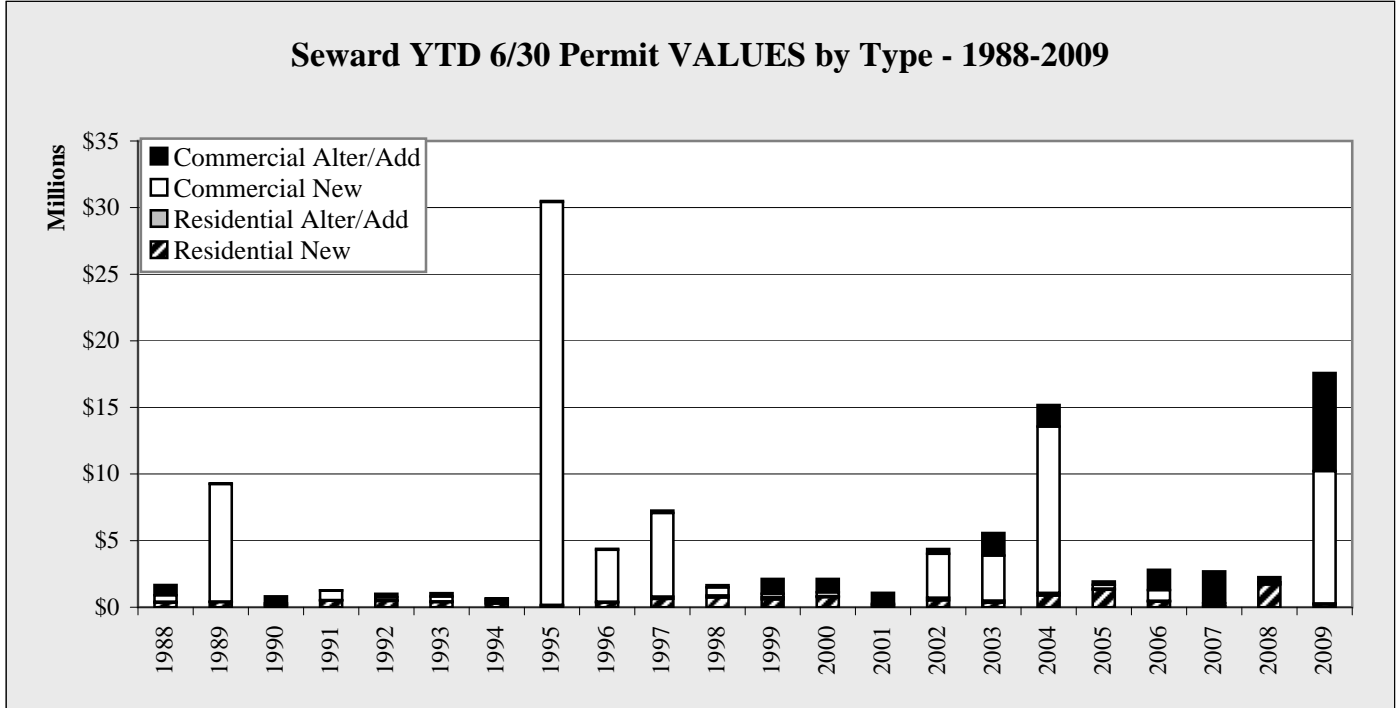

Chart 5.23

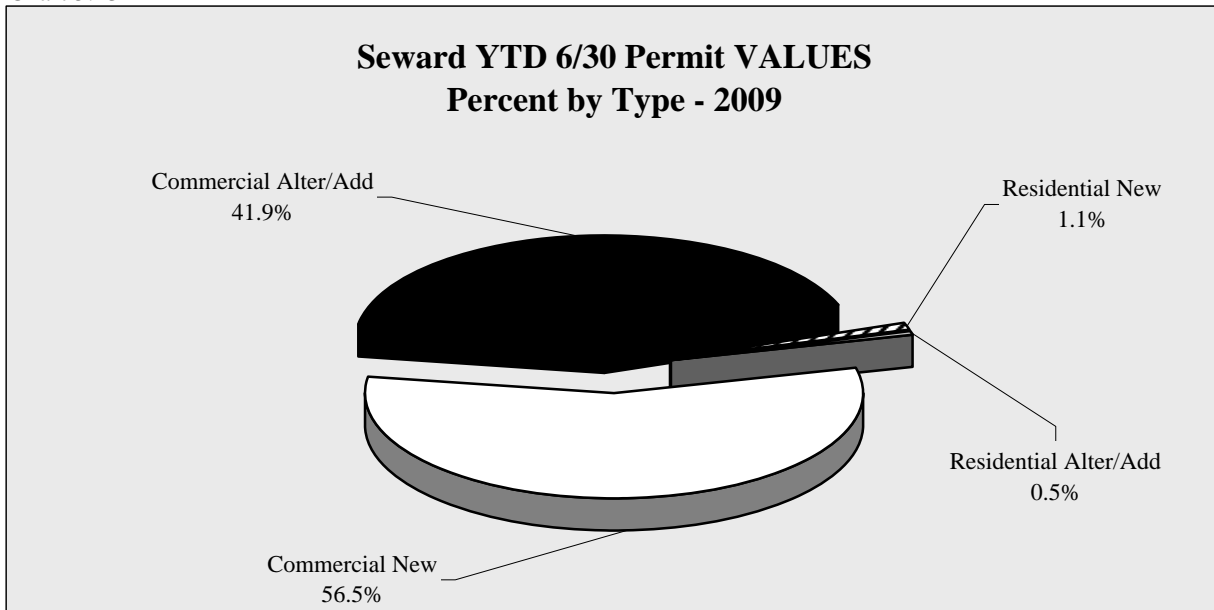

Chart 5.24

Seward Construction

Seward YTD 6/30 Permit VOLUME by Type - 2003-2009								
	2003	2004	2005	2006	2007	2008	2009	Annual Change
Residential New	3	4	7	3	1	3	1	-66.7%
Residential Alter/Add	5	9	11	8	2	8	10	25.0%
Commercial New	5	2	7	11	1	0	7	NA
Commercial Alter/Add	11	13	6	8	14	6	11	83.3%
Total	24	28	31	30	18	17	29	70.6%
Annual Change		16.7%	10.7%	-3.2%	-40.0%	-5.6%	70.6%	

Table 5.31

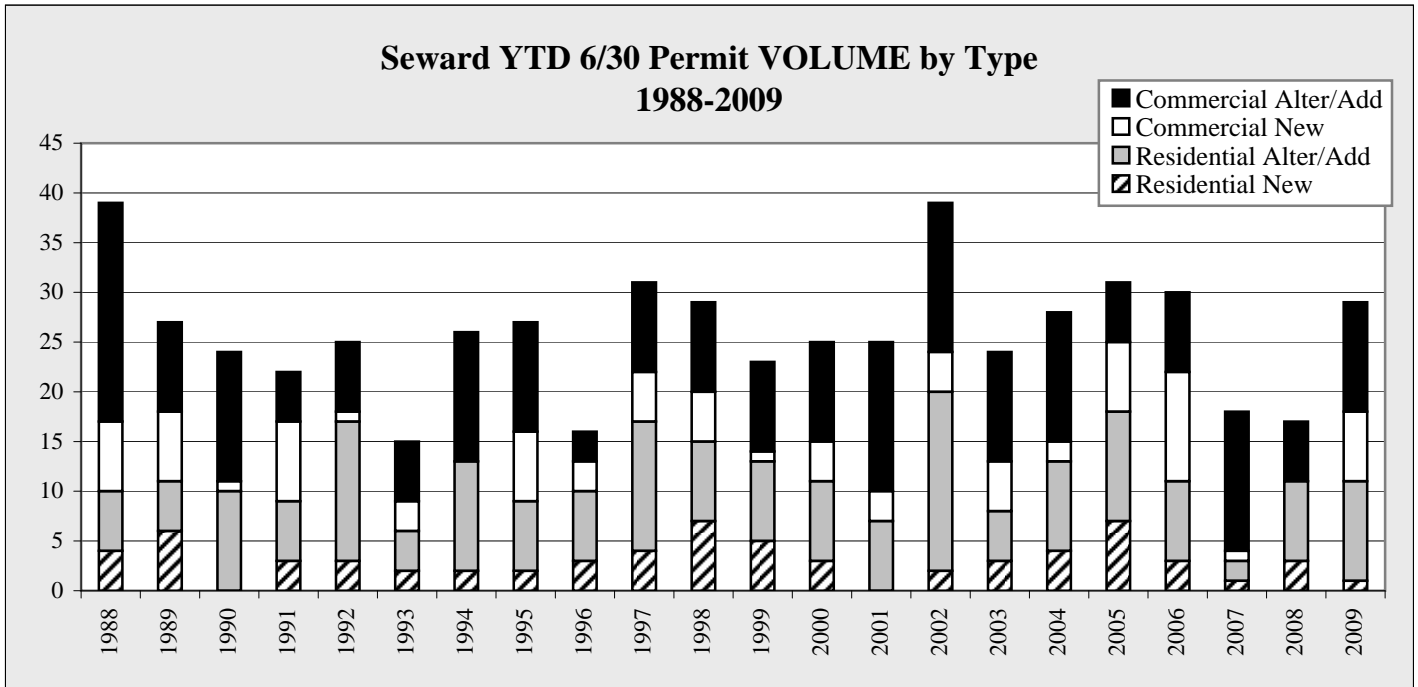

Chart 5.25

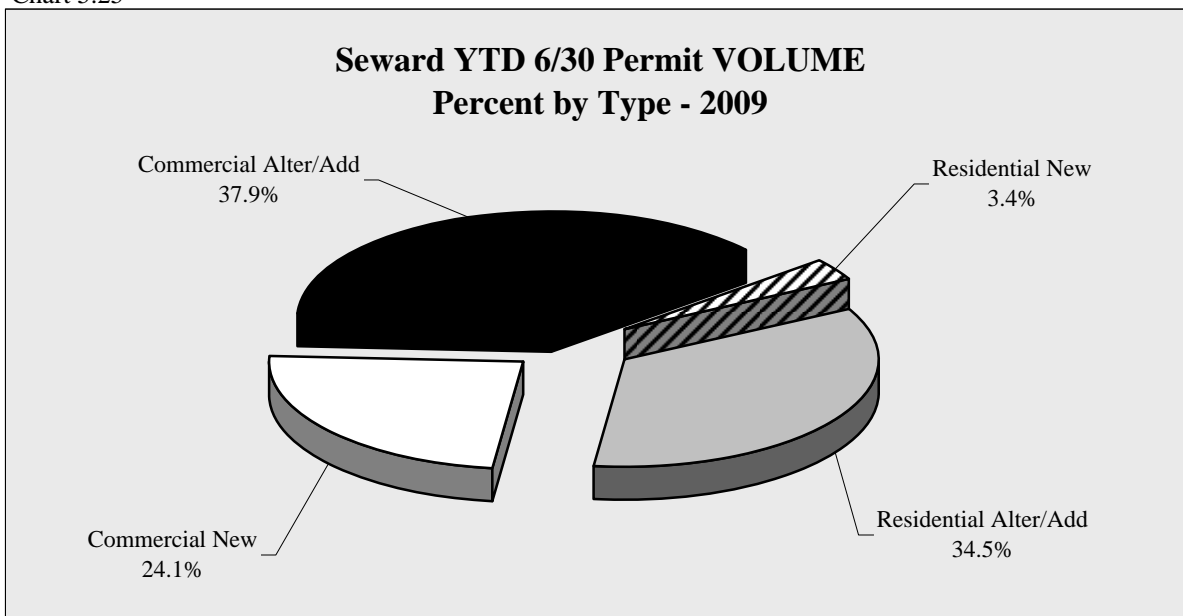

Chart 5.26

Seward Construction

Seward Annual Permit VALUES by Type by Quarter - 2002-2009 - in \$					
	1st Quarter	2nd Quarter	3rd Quarter	4th Quarter	Total
2002					
Residential - New	120,000	400,000	205,000	0	725,000
Residential - Add/Alter	25,496	169,157	27,555	19,800	242,008
Commercial - New	0	3,294,730	750,000	2,100,000	6,144,730
Commercial - Add/Alter	335,944	25,000	325,021	113,000	798,965
TOTAL	481,440	3,888,887	1,307,576	2,232,800	7,910,703
2003					
Residential - New	118,000	215,000	744,500	0	1,077,500
Residential - Add/Alter	57,500	100,000	87,000	50,000	294,500
Commercial - New	72,000	3,313,000	900,000	5,000	4,290,000
Commercial - Add/Alter	1,657,855	44,010	101,400	517,500	2,320,765
TOTAL	1,905,355	3,672,010	1,832,900	572,500	7,982,765
2004					
Residential - New	0	873,000	1,257,000	0	2,130,000
Residential - Add/Alter	48,000	144,900	299,500	8,000	500,400
Commercial - New	7,500,000	5,000,000	518,800	0	13,018,800
Commercial - Add/Alter	193,600	1,426,000	191,000	251,350	2,061,950
TOTAL	7,741,600	7,443,900	2,266,300	259,350	17,711,150
2005					
Residential - New	923,000	388,000	455,000	1,500	1,767,500
Residential - Add/Alter	3,300	84,220	6,761	40,457	134,738
Commercial - New	6,000	271,320	88,400	60,000	425,720
Commercial - Add/Alter	240,000	15,000	275,285	4,900	535,185
TOTAL	1,172,300	758,540	825,446	106,857	2,863,143
2006					
Residential - New	0	415,000	703,000	0	1,118,000
Residential - Add/Alter	1,000	65,200	7,192	13,000	86,392
Commercial - New	0	800,000	19,700,000	1,896,300	22,396,300
Commercial - Add/Alter	621,217	904,472	375,868	35,000	1,936,557
TOTAL	622,217	2,184,672	20,786,060	1,944,300	25,537,249
2007					
Residential - New	0	82,354	170,000	0	252,354
Residential - Add/Alter	0	13,000	46,400	118,000	177,400
Commercial - New	208,513	0	7,500	18,000,000	18,216,013
Commercial - Add/Alter	594,725	1,792,933	41,000	21,500	2,450,158
TOTAL	803,238	1,888,287	264,900	18,139,500	21,095,925
2008					
Residential - New	0	1,700,000	0	0	1,700,000
Residential - Add/Alter	45,415	128,964	9,500	45,000	228,879
Commercial - New	0	0	200,000	125,000	325,000
Commercial - Add/Alter	364,000	15,500	7,000	192,000	578,500
TOTAL	409,415	1,844,464	216,500	362,000	2,832,379
2009					
Residential - New	0	200,000			200,000
Residential - Add/Alter	9,500	70,650			80,150
Commercial - New	353,000	9,583,649			9,936,649
Commercial - Add/Alter	6,264,620	1,104,500			7,369,120
TOTAL	6,627,120	10,958,799	0	0	17,585,919
					Year to Date

Table 5.33

Seward Construction

Seward Annual Permit VOLUME by Type by Quarter - 2002-2009					
	1st Quarter	2nd Quarter	3rd Quarter	4th Quarter	Total
2002					
Residential - New	1	1	2	0	4
Residential - Add/Alter	3	15	3	4	25
Commercial - New	0	4	1	3	8
Commercial - Add/Alter	6	9	8	4	27
TOTAL	10	29	14	11	64
2003					
Residential - New	1	2	5	0	8
Residential - Add/Alter	2	3	5	1	11
Commercial - New	1	4	1	1	7
Commercial - Add/Alter	7	4	4	9	24
TOTAL	11	13	15	11	50
2004					
Residential - New	0	4	8	0	12
Residential - Add/Alter	2	7	5	1	15
Commercial - New	1	1	2	0	4
Commercial - Add/Alter	4	9	4	6	23
TOTAL	7	21	19	7	54
2005					
Residential - New	4	3	3	1	11
Residential - Add/Alter	2	9	5	3	19
Commercial - New	2	5	2	1	10
Commercial - Add/Alter	4	2	6	2	14
TOTAL	12	19	16	7	54
2006					
Residential - New	0	3	5	0	8
Residential - Add/Alter	1	7	4	1	13
Commercial - New	0	11	2	4	17
Commercial - Add/Alter	6	2	8	1	17
TOTAL	7	23	19	6	55
2007					
Residential - New	0	1	1	0	2
Residential - Add/Alter	0	2	6	4	12
Commercial - New	1	0	1	1	3
Commercial - Add/Alter	6	8	2	4	20
TOTAL	7	11	10	9	37
2008					
Residential - New	0	3	0	0	3
Residential - Add/Alter	1	7	2	3	13
Commercial - New	0	0	1	1	2
Commercial - Add/Alter	4	2	1	5	12
TOTAL	5	12	4	9	30
2009					Year to Date
Residential - New	0	1			1
Residential - Add/Alter	1	9			10
Commercial - New	2	5			7
Commercial - Add/Alter	4	7			11
TOTAL	7	22	0	0	29

Table 5.24

SOLDOTNA

Soldotna Sales

Soldotna Second Quarter GROSS Sales by Line of Business - 2004-2009 - in \$								
LOB	2004	2005	2006	2007	2008	2009	Annual Percent Change	Annual \$ Amount Change
PROD	141,776	160,747	33,737	503,137	67,144	30,277	-54.9%	-36,867
SALES	52,573,343	55,923,754	55,849,341	59,388,188	74,429,481	71,234,523	-4.3%	-3,194,958
CONST	5,387,106	4,117,881	12,052,501	8,752,976	5,474,282	6,292,872	15.0%	818,590
PROP	3,670,133	4,109,952	4,408,627	4,457,968	5,629,677	4,667,127	-17.1%	-962,550
TOUR	6,477,516	6,813,740	7,475,480	7,236,035	2,208,313	1,723,328	-22.0%	-484,985
SERV	5,047,977	5,120,763	6,137,670	8,785,600	8,694,118	7,132,615	-18.0%	-1,561,503
PROF	2,168,937	2,290,228	2,648,600	3,326,667	3,617,747	2,665,045	-26.3%	-952,702
UTIL	1,459,715	1,861,397	2,118,707	2,351,351	2,681,735	3,225,551	20.3%	543,816
MANU	1,213,708	2,242,896	2,477,219	2,893,476	2,353,456	2,990,505	27.1%	637,049
TRAN	1,266,221	1,768,221	2,200,316	1,305,230	3,573,842	2,082,969	-41.7%	-1,490,873
WHLS	9,622,133	2,993,234	3,350,490	3,495,025	3,420,857	4,374,487	27.9%	953,630
GOV	281,564	237,176	268,747	340,977	305,388	351,024	14.9%	45,636
TOTAL	89,310,129	87,639,989	99,021,435	102,836,630	112,456,040	106,770,323	-5.1%	-5,685,717

Table 6.1 For complete listing of Lines of Business, see page 17

Soldotna Second Quarter GROSS Sales History	
2004	89,310,129
2005	87,639,989
2006	99,021,435
2007	102,836,630
2008	112,456,040
2009	106,770,323

Table 6.2

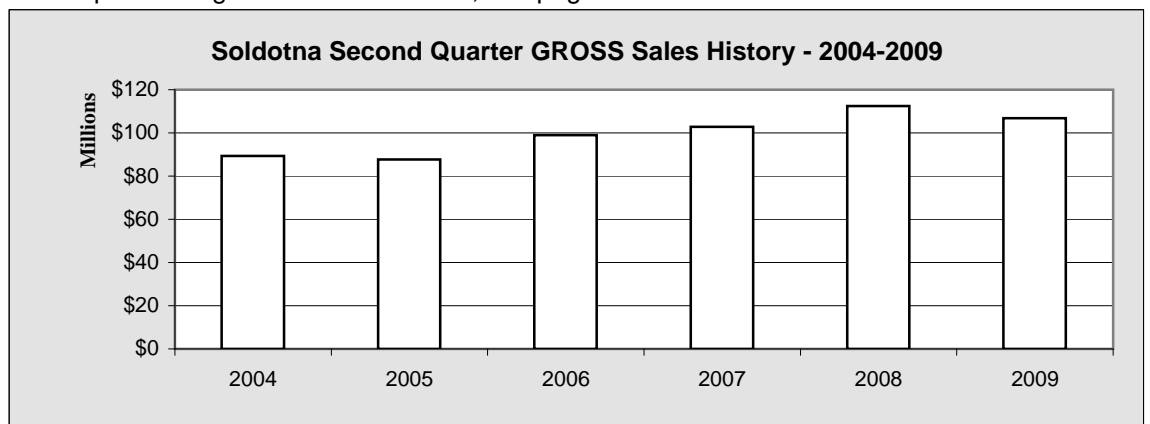

Chart 6.1

Soldotna Five Year Change Second Quarter GROSS Sales		
LOB	2004	2009
PROD	141,776	30,277
SALES	52,573,343	71,234,523
CONST	5,387,106	6,292,872
PROP	3,670,133	4,667,127
TOUR	6,477,516	1,723,328
SERV	5,047,977	7,132,615
PROF	2,168,937	2,665,045
UTIL	1,459,715	3,225,551
MANU	1,213,708	2,990,505
TRAN	1,266,221	2,082,969
WHLS	9,622,133	4,374,487
GOV	281,564	351,024
TOTAL	89,310,129	106,770,323

Table 6.3

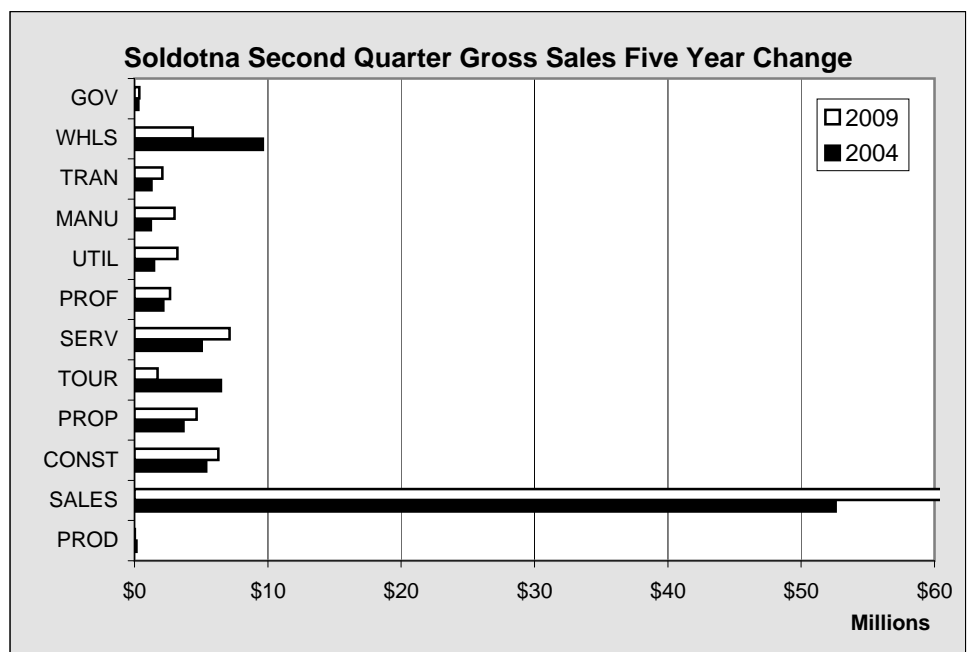

Chart 6.2

Soldotna Sales

Soldotna Second Quarter TAXABLE Sales by Line of Business - 2004-2009 - in \$								
LOB	2004	2005	2006	2007	2008	2009	Annual Percent Change	Annual Amount Change
PROD	6,821	7,109	14,023	17,491	17,310	7,794	-55.0%	-9,516
SALES	34,026,583	36,912,626	38,817,334	42,044,799	49,975,174	47,785,845	-4.4%	-2,189,329
CONST	275,602	249,699	253,076	241,760	242,024	309,731	28.0%	67,707
PROP	1,600,705	1,618,112	1,609,694	2,116,638	2,420,172	2,009,671	-17.0%	-410,501
TOUR	6,067,958	6,410,759	6,787,726	6,247,463	1,715,773	1,395,914	-18.6%	-319,859
SERV	4,002,336	3,872,567	4,222,088	4,716,519	4,904,238	5,130,924	4.6%	226,686
PROF	1,026,141	911,827	1,159,056	1,213,456	1,406,757	1,285,035	-8.7%	-121,722
UTIL	833,369	979,377	1,109,739	1,264,657	1,343,839	1,538,897	14.5%	195,058
MANU	306,253	282,123	714,499	757,253	336,282	324,198	-3.6%	-12,084
TRAN	122,474	161,304	21,151	32,356	22,474	53,072	136.1%	30,598
WHLS	499,633	534,128	498,696	459,955	539,333	410,369	-23.9%	-128,964
GOV	243,868	205,613	231,090	294,789	255,936	265,403	3.7%	9,467
TOTAL	49,011,743	52,145,244	55,438,172	59,407,136	63,179,312	60,516,853	-4.2%	-2,662,459

Table 6.4

For complete listing of Lines of Business, see page 17

Soldotna Second Quarter TAXABLE Sales History	
2004	49,011,743
2005	52,145,244
2006	55,438,172
2007	59,407,136
2008	63,179,312
2009	60,516,853

Table 6.5

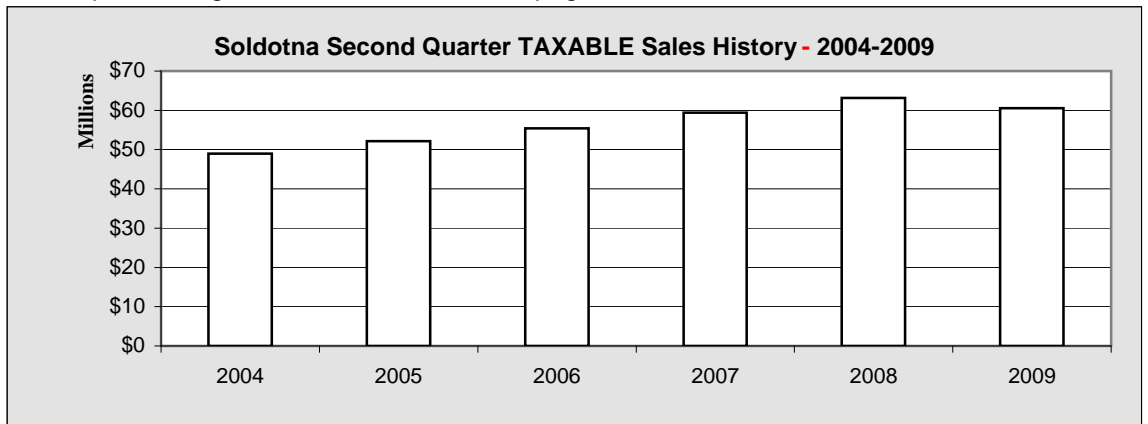

Chart 6.3

Soldotna Five Year Change Second Quarter TAXABLE Sales		
LOB	2004	2009
PROD	6,821	7,794
SALES	34,026,583	47,785,845
CONST	275,602	309,731
PROP	1,600,705	2,009,671
TOUR	6,067,958	1,395,914
SERV	4,002,336	5,130,924
PROF	1,026,141	1,285,035
UTIL	833,369	1,538,897
MANU	306,253	324,198
TRAN	122,474	53,072
WHLS	499,633	410,369
GOV	243,868	265,403
TOTAL	49,011,743	60,516,853

Table 6.6

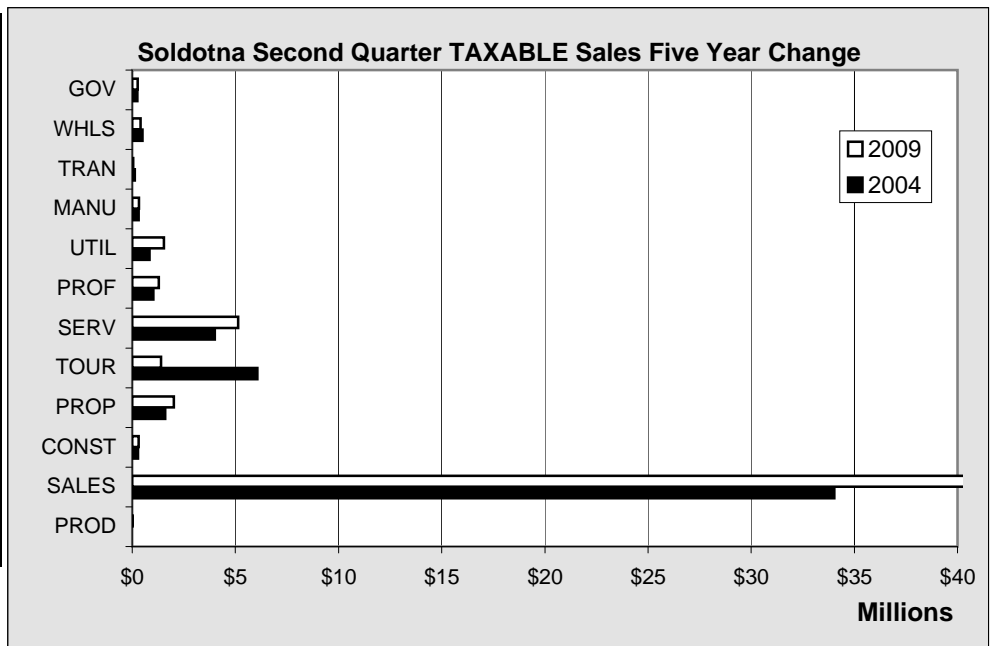

Chart 6.4

Soldotna Sales

Soldotna YTD June 30 GROSS Sales by Line of Business - 2004-2009 - in \$								
LOB	2004	2005	2006	2007	2008	2009	Annual Percent Change	Annual Amount Change
PROD	208,227	224,733	43,245	719,464	141,542	44,169	-68.8%	-97,373
SALES	91,557,709	96,624,960	97,934,380	104,958,781	132,049,577	122,506,167	-7.2%	-9,543,410
CONST	7,845,109	8,493,432	18,137,667	16,018,043	12,820,469	10,346,271	-19.3%	-2,474,198
PROP	7,476,766	7,521,959	8,192,706	8,481,213	9,931,329	8,466,358	-14.8%	-1,464,971
TOUR	10,892,913	11,323,847	12,375,833	12,202,628	3,235,071	2,365,362	-26.9%	-869,709
SERV	9,607,954	9,316,424	10,825,855	14,569,362	15,305,524	13,365,208	-12.7%	-1,940,316
PROF	4,337,355	4,518,706	5,916,562	6,091,580	6,887,849	5,856,517	-15.0%	-1,031,332
UTIL	3,468,173	4,411,007	5,131,242	5,998,336	6,445,731	8,236,317	27.8%	1,790,586
MANU	2,285,393	3,327,637	3,929,683	4,706,576	3,890,820	4,325,868	11.2%	435,048
TRAN	1,812,890	2,505,106	2,976,538	1,960,105	4,636,382	3,438,133	-25.8%	-1,198,249
WHLS	19,270,770	4,871,480	5,495,735	5,778,934	6,070,036	7,331,463	20.8%	1,261,427
GOV	476,538	456,843	519,032	610,109	579,740	632,874	9.2%	53,134
TOTAL	159,239,797	153,596,134	171,478,478	182,095,131	201,994,070	186,914,707	-7.5%	-15,079,363

Table 6.7

For complete listing of Lines of Business, see page 17

Soldotna YTD June 30 GROSS Sales History	
2004	159,239,797
2005	153,596,134
2006	171,478,478
2007	182,095,131
2008	201,994,070
2009	186,914,707

Table 6.8

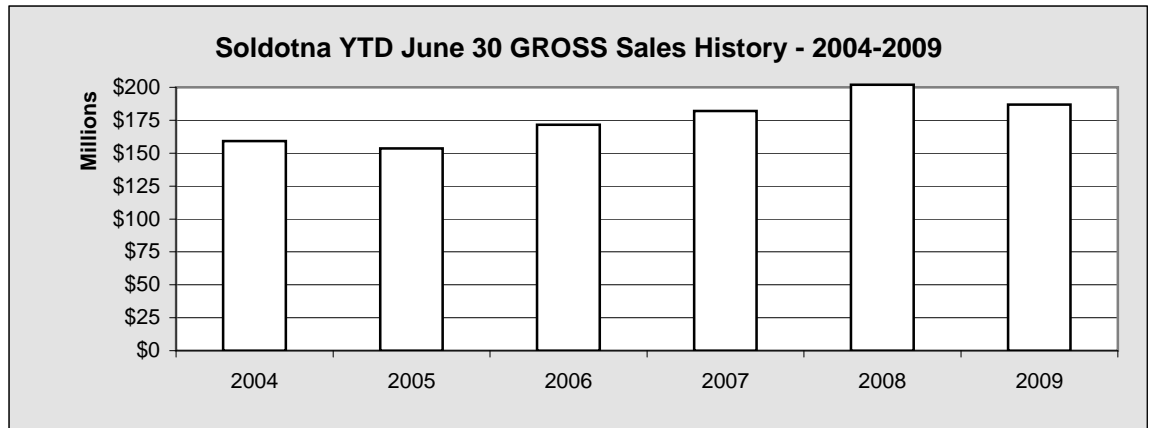

Chart 6.5

Soldotna Five Year Change YTD June 30 GROSS Sales		
	2004	2009
PROD	208,227	44,169
SALES	91,557,709	122,506,167
CONST	7,845,109	10,346,271
PROP	7,476,766	8,466,358
TOUR	10,892,913	2,365,362
SERV	9,607,954	13,365,208
PROF	4,337,355	5,856,517
UTIL	3,468,173	8,236,317
MANU	2,285,393	4,325,868
TRAN	1,812,890	3,438,133
WHLS	19,270,770	7,331,463
GOV	476,538	632,874
TOTAL	159,239,797	186,914,707

Table 6.9

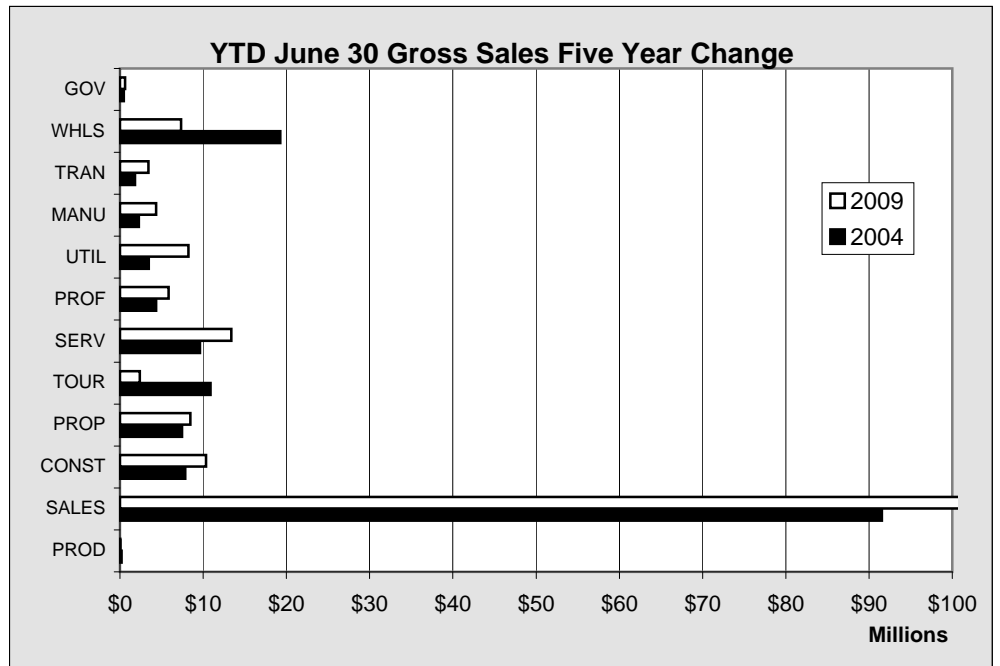

Chart 6.6

Soldotna Sales

Soldotna YTD June 30 TAXABLE Sales by Line of Business - 2004-2009 - in \$								
LOB	2004	2005	2006	2007	2008	2009	Annual Percent Change	Annual Amount Change
PROD	11,414	8,554	16,013	20,879	20,679	9,632	-53.4%	-11,047
SALES	59,112,684	63,442,383	66,517,656	72,948,035	86,847,215	83,304,549	-4.1%	-3,542,666
CONST	503,674	500,479	462,889	440,948	426,475	520,540	22.1%	94,065
PROP	2,979,645	3,072,912	3,141,400	3,417,958	4,147,175	3,667,248	-11.6%	-479,927
TOUR	10,183,343	10,614,681	11,603,546	11,371,293	2,508,540	1,862,264	-25.8%	-646,276
SERV	7,654,261	7,129,372	7,975,995	8,931,307	9,040,869	9,729,853	7.6%	688,984
PROF	1,936,967	1,814,523	2,118,965	2,156,467	2,663,463	2,525,492	-5.2%	-137,971
UTIL	2,048,806	2,321,255	2,730,993	3,171,616	3,128,307	4,002,332	27.9%	874,025
MANU	360,441	338,418	1,242,326	1,172,649	459,515	417,798	-9.1%	-41,717
TRAN	168,182	209,777	334,691	166,796	41,022	75,775	84.7%	34,753
WHLS	1,018,834	1,008,926	971,216	938,731	1,071,836	852,513	-20.5%	-219,323
GOV	418,834	398,636	446,109	520,872	484,767	508,129	4.8%	23,362
TOTAL	86,397,085	90,859,916	97,561,799	105,257,551	110,839,863	107,476,125	-3.0%	-3,363,738

Table 6.10

For complete listing of Lines of Business, see page 17

Soldotna YTD June 30 TAXABLE Sales History	
2004	86,397,085
2005	90,859,916
2006	97,561,799
2007	105,257,551
2008	110,839,863
2009	107,476,125

Table 6.11

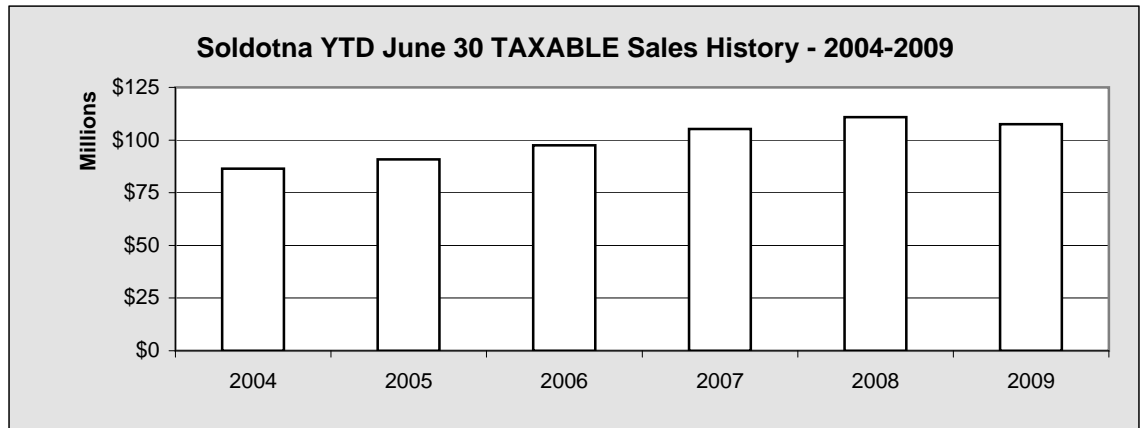

Chart 6.7

Soldotna Five Year Change YTD June 30 TAXABLE Sales		
	2004	2009
PROD	11,414	9,632
SALES	59,112,684	83,304,549
CONST	503,674	520,540
PROP	2,979,645	3,667,248
TOUR	10,183,343	1,862,264
SERV	7,654,261	9,729,853
PROF	1,936,967	2,525,492
UTIL	2,048,806	4,002,332
MANU	360,441	417,798
TRAN	168,182	75,775
WHLS	1,018,834	852,513
GOV	418,834	508,129
TOTAL	86,397,085	107,476,125

Table 6.12

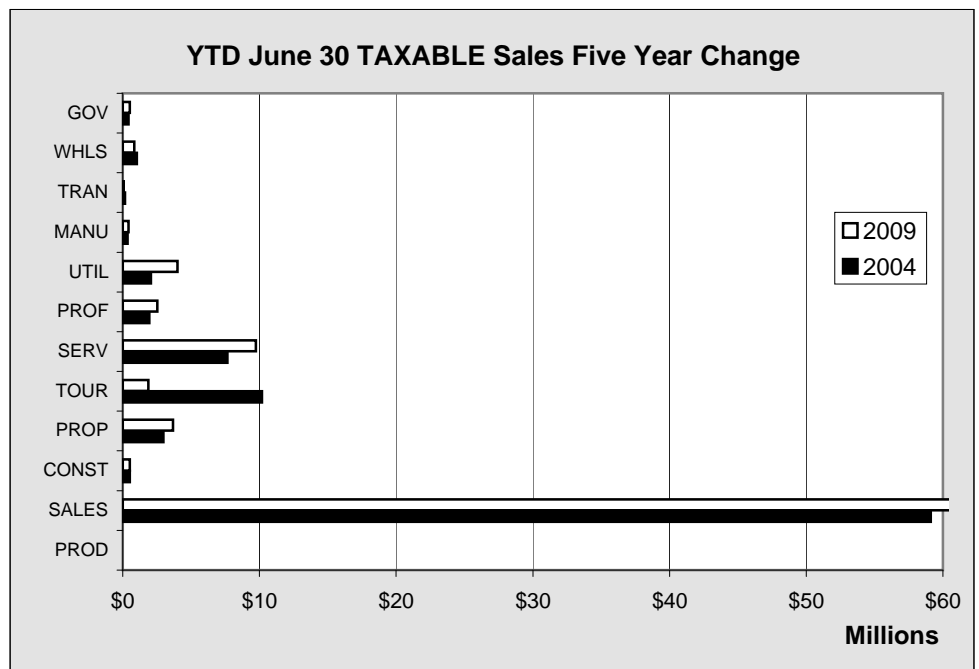

Chart 6.8

Soldotna Sales

Soldotna Annual GROSS Sales by Line of Business - 2003-2008 - in \$								
LOB	2003	2004	2005	2006	2007	2008	Annual Percent Change	Annual Amount Change
PROD	425,497	501,400	438,718	213,456	920,490	276,855	-69.9%	-643,635
SALES	201,426,315	212,835,934	219,656,619	230,020,343	247,381,780	305,621,161	23.5%	58,239,381
CONST	18,592,599	25,977,708	60,647,837	73,482,023	43,636,826	33,873,057	-22.4%	-9,763,769
PROP	15,014,093	15,977,058	15,638,823	18,401,722	18,875,156	19,612,870	3.9%	737,714
TOUR	22,794,234	24,557,709	26,157,699	29,550,690	26,893,691	20,808,636	-22.6%	-6,085,055
SERV	18,034,222	19,883,143	19,472,878	23,474,072	32,332,923	29,408,020	-9.0%	-2,924,903
PROF	10,359,952	13,652,017	14,717,603	16,102,094	15,707,527	19,551,347	24.5%	3,843,820
UTIL	6,868,788	7,753,204	8,447,844	10,027,542	11,047,821	12,437,580	12.6%	1,389,759
MANU	10,450,535	7,146,598	10,076,540	10,866,104	11,886,354	10,015,150	-15.7%	-1,871,204
TRAN	533,819	3,017,321	4,736,701	4,140,863	5,695,881	10,750,934	88.7%	5,055,053
WHLS	32,548,455	28,991,155	15,036,051	15,456,999	13,769,409	14,033,336	1.9%	263,927
GOV	857,491	965,632	1,006,150	1,119,273	1,147,529	1,188,534	3.6%	41,005
TOTAL	337,906,000	361,258,879	396,033,463	432,855,181	429,295,387	477,577,480	11.2%	48,282,093

Table 6.13

For complete listing of Lines of Business, see page 17

Soldotna Annual GROSS Sales History	
2003	337,906,000
2004	361,258,879
2005	396,033,463
2006	432,855,181
2007	429,295,387
2008	477,577,480

Table 6.14

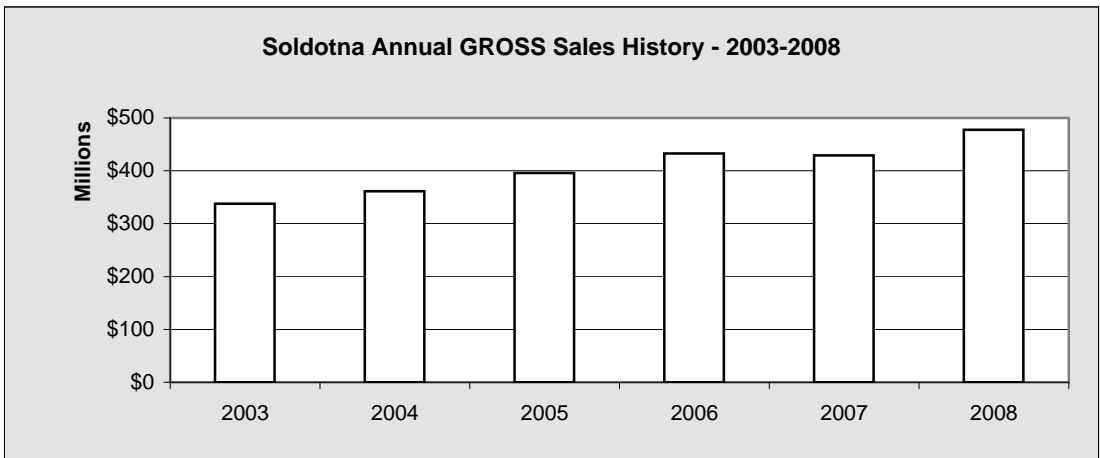

Chart 6.9

Five Year Change Annual GROSS Sales		
LOB	2003	2008
PROD	425,497	276,855
SALES	201,426,315	305,621,161
CONST	18,592,599	33,873,057
PROP	15,014,093	19,612,870
TOUR	22,794,234	#REF!
SERV	18,034,222	29,408,020
PROF	10,359,952	19,551,347
UTIL	6,868,788	12,437,580
MANU	10,450,535	10,015,150
TRAN	533,819	10,750,934
WHLS	32,548,455	14,033,336
GOV	857,491	1,188,534
TOTAL	337,906,000	477,577,480

Table 6.15

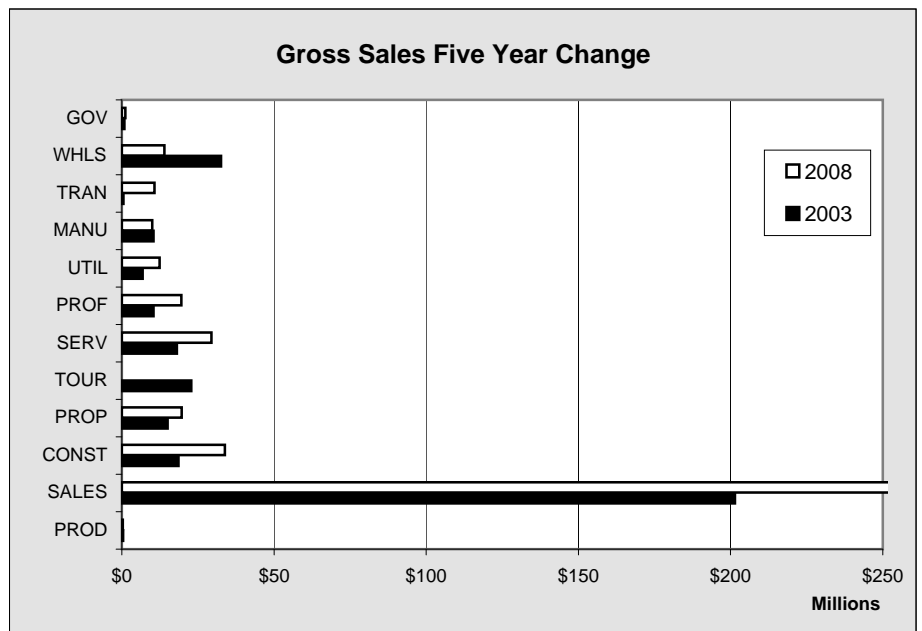

Chart 6.10

Soldotna Sales

Soldotna Annual TAXABLE Sales by Line of Business - 2003-2008 - in \$								
LOB	2003	2004	2005	2006	2007	2008	Annual Percent Change	Annual Amount Change
PROD	53,445	24,403	29,575	34,327	43,133	50,577	17.3%	7,444
SALES	135,997,009	143,250,121	152,149,810	162,055,202	175,657,256	209,999,367	19.6%	34,342,111
CONST	1,123,434	1,054,535	1,002,298	938,809	985,188	944,534	-4.1%	-40,654
PROP	6,225,915	6,558,835	6,578,222	6,825,029	8,171,789	8,204,532	0.4%	32,743
TOUR	20,772,105	21,979,858	23,398,168	25,066,602	24,042,079	18,592,611	-22.7%	-5,449,468
SERV	14,519,872	15,017,384	14,635,114	16,794,536	17,923,945	19,118,781	6.7%	1,194,836
PROF	3,665,152	3,675,592	3,591,626	4,013,780	4,398,267	5,003,549	13.8%	605,282
UTIL	3,712,214	3,898,545	4,410,657	5,169,826	5,662,440	5,932,835	4.8%	270,395
MANU	1,421,516	1,511,891	2,165,467	3,405,902	3,114,350	1,801,023	-42.2%	-1,313,327
TRAN	170,122	66,563	114,607	104,245	196,204	78,963	-59.8%	-117,241
WHLS	2,235,271	2,209,742	2,263,975	2,178,318	2,332,434	2,391,044	2.5%	58,610
GOV	731,717	812,079	870,925	958,451	968,136	967,141	-0.1%	-995
TOTAL	190,627,772	200,059,548	211,210,444	227,545,027	243,495,221	273,084,957	12.2%	29,589,736

Table 6.16

For complete listing of Lines of Business, see page 17

Soldotna Annual TAXABLE Sales History	
2003	190,627,772
2004	200,059,548
2005	211,210,444
2006	227,545,027
2007	243,495,221
2008	273,084,957

Table 6.17

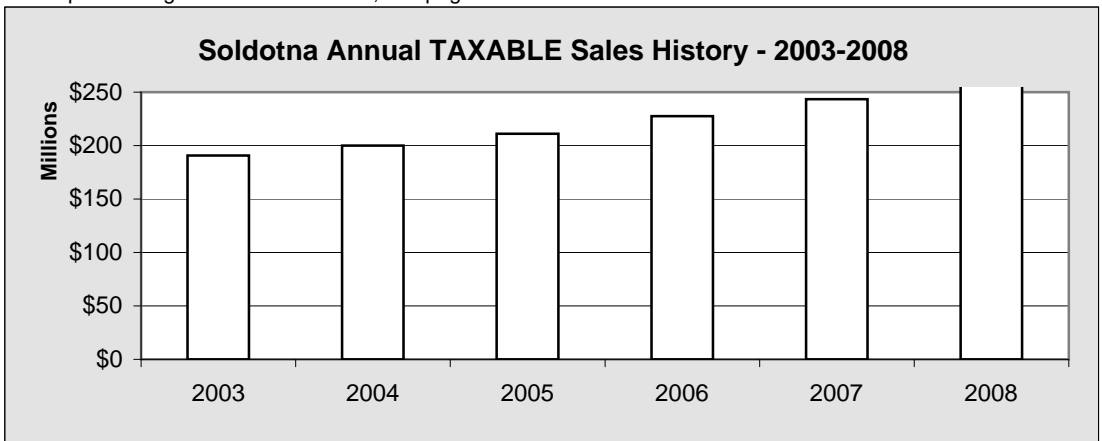
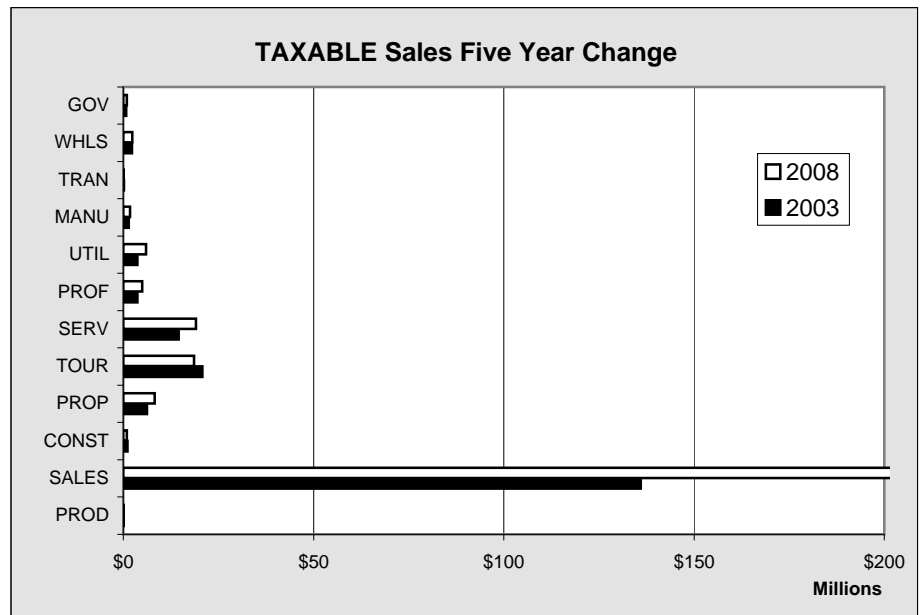

Chart 6.11

Five Year Change Annual TAXABLE Sales		
LOB	2003	2008
PROD	53,445	50,577
SALES	135,997,009	209,999,367
CONST	1,123,434	944,534
PROP	6,225,915	8,204,532
TOUR	20,772,105	18,592,611
SERV	14,519,872	19,118,781
PROF	3,665,152	5,003,549
UTIL	3,712,214	5,932,835
MANU	1,421,516	1,801,023
TRAN	170,122	78,963
WHLS	2,235,271	2,391,044
GOV	731,717	967,141
TOTAL	190,627,772	273,084,957

Table 6.18

Chart 6.12



Soldotna Sales

Soldotna GROSS Sales by Line of Business by Quarter - 2008 - in \$					
	1st Quarter	2nd Quarter	3rd Quarter	4th Quarter	Total
Resource Production	74,398	67,144	86,128	49,185	276,855
Sales	57,620,096	74,429,481	98,802,473	74,769,111	305,621,161
Construction	7,346,187	5,474,282	11,655,991	9,396,597	33,873,057
Property	4,301,652	5,629,677	5,140,874	4,540,667	19,612,870
Tourism	4,053,363	6,103,527	9,616,242	1,035,504	20,808,636
Services	6,611,406	8,694,118	7,553,458	6,549,038	29,408,020
Professional	3,270,102	3,617,747	3,859,050	8,804,448	19,551,347
Utility	3,763,996	2,681,735	2,323,815	3,668,034	12,437,580
Manufacturing	1,537,364	2,353,456	3,700,065	2,424,265	10,015,150
Transporation & Warehousing	1,062,540	3,573,842	4,389,892	1,724,660	10,750,934
Wholesale	2,649,179	3,420,857	4,204,743	3,758,557	14,033,336
Government	274,352	305,388	337,345	271,449	1,188,534
TOTAL	92,564,635	116,351,254	151,670,076	116,991,515	477,577,480

Table 6.19

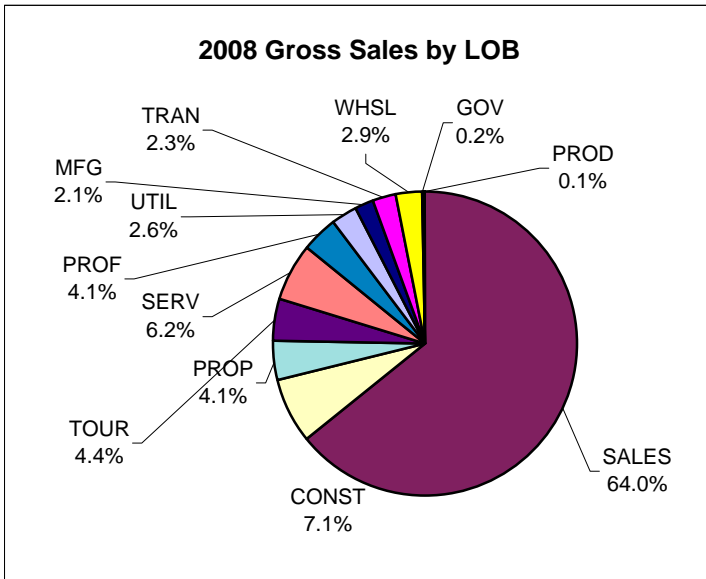

Chart 6.13

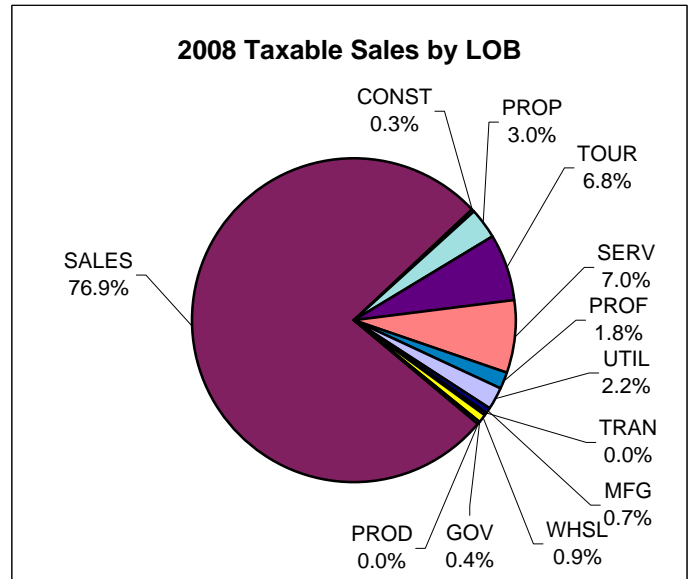

Chart 6.14

Soldotna TAXABLE Sales by Line of Business by Quarter - 2008 - in \$					
LOB	1st Quarter	2nd Quarter	3rd Quarter	4th Quarter	Total
Resource Production	3,369	17,310	20,390	9,508	50,577
Sales	36,872,041	49,975,174	75,154,546	47,997,606	209,999,367
Construction	184,451	242,024	268,726	249,333	944,534
Property	1,727,003	2,420,172	2,165,942	1,891,415	8,204,532
Tourism	3,731,548	5,534,014	8,586,460	740,589	18,592,611
Services	4,136,631	4,904,238	5,338,529	4,739,383	19,118,781
Professional	1,256,706	1,406,757	1,274,356	1,065,730	5,003,549
Utility	1,784,468	1,343,839	1,066,864	1,737,664	5,932,835
Manufacturing	123,233	336,282	1,182,129	159,379	1,801,023
Transporation & Warehousing	18,548	22,474	16,018	21,923	78,963
Wholesale	532,503	539,333	567,388	751,820	2,391,044
Government	228,831	255,936	258,870	223,504	967,141
TOTAL	50,599,332	66,997,553	95,900,218	59,587,854	273,084,957

Table 6.20

Soldotna Sales

Soldotna GROSS Sales by Line of Business by Quarter - 2007 - in \$

LOB	1st Quarter	2nd Quarter	3rd Quarter	4th Quarter	Total
Resource Production	214,787	494,187	156,935	54,581	920,490
Sales	45,880,130	60,021,298	80,221,447	61,258,905	247,381,780
Construction	7,265,067	8,759,070	8,626,546	18,986,143	43,636,826
Property	4,023,704	4,458,148	5,160,907	5,232,397	18,875,156
Tourism	4,657,506	6,881,869	10,438,337	4,915,979	26,893,691
Services	5,783,803	8,786,410	9,298,488	8,464,222	32,332,923
Professional	2,766,453	3,331,477	2,788,887	6,820,710	15,707,527
Utility	3,646,985	2,351,351	2,280,478	2,769,007	11,047,821
Manufacturing	1,813,100	2,995,574	4,466,226	2,611,454	11,886,354
Transporation & Warehousing	654,875	1,050,794	2,504,599	1,485,613	5,695,881
Wholesale	2,283,909	3,495,025	3,985,512	4,004,963	13,769,409
Government	269,132	340,977	271,583	265,837	1,147,529
TOTAL	79,259,451	102,966,180	130,199,945	116,869,811	429,295,387

Table 6.21

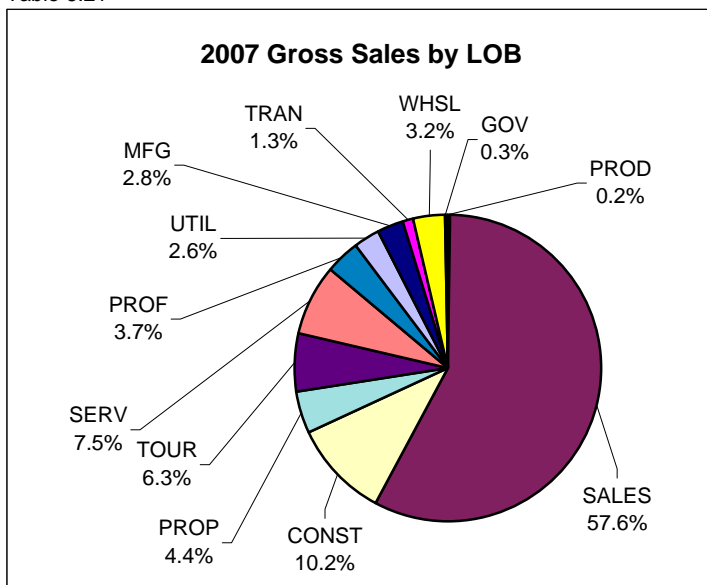

Chart 6.15

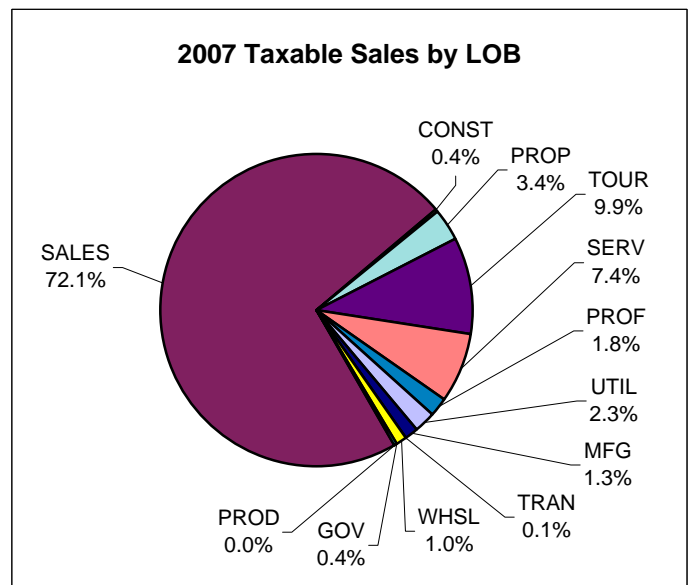

Chart 6.16

Soldotna TAXABLE Sales by Line of Business by Quarter - 2007 - in \$

LOB	1st Quarter	2nd Quarter	3rd Quarter	4th Quarter	Total
Resource Production	1,838	17,491	18,088	5,716	43,133
Sales	31,845,883	42,044,799	59,266,959	42,499,615	175,657,256
Construction	198,072	241,760	264,300	281,056	985,188
Property	1,563,929	2,116,638	2,134,804	2,356,418	8,171,789
Tourism	4,316,624	6,247,463	9,078,308	4,399,684	24,042,079
Services	3,846,764	4,716,519	4,723,490	4,637,172	17,923,945
Professional	1,051,966	1,213,456	1,084,516	1,048,329	4,398,267
Utility	1,906,959	1,264,657	1,080,514	1,410,310	5,662,440
Manufacturing	423,409	757,253	1,679,741	253,947	3,114,350
Transporation & Warehousing	21,317	32,356	17,353	125,178	196,204
Wholesale	478,776	459,955	517,761	875,942	2,332,434
Government	226,083	294,789	227,333	219,931	968,136
TOTAL	45,881,620	59,407,136	80,093,167	58,113,298	243,495,221

Table 6.22

Soldotna Sales

Soldotna GROSS Sales by Line of Business by Quarter - 2006 - in \$					
LOB	1st Quarter	2nd Quarter	3rd Quarter	4th Quarter	Total
Resource Production	9,508	28,662	29,583	145,703	213,456
Sales	42,375,450	56,353,527	75,149,572	56,141,794	230,020,343
Construction	6,085,166	12,052,501	9,164,421	46,179,935	73,482,023
Property	3,784,079	4,408,627	4,931,224	5,277,792	18,401,722
Tourism	4,610,986	7,895,934	11,777,125	5,266,645	29,550,690
Services	4,688,676	6,130,248	6,586,677	6,068,471	23,474,072
Professional	3,267,962	2,648,600	2,517,005	7,668,527	16,102,094
Utility	3,012,535	2,118,707	1,852,957	3,043,343	10,027,542
Manufacturing	1,452,464	2,477,219	4,186,336	2,750,085	10,866,104
Transporation & Warehousing	774,795	1,279,552	1,168,980	917,536	4,140,863
Wholesale	2,145,245	3,350,490	3,466,478	6,494,786	15,456,999
Government	250,285	268,747	337,436	262,805	1,119,273
TOTAL	72,457,151	99,012,814	121,167,794	140,217,422	432,855,181

Table 6.23

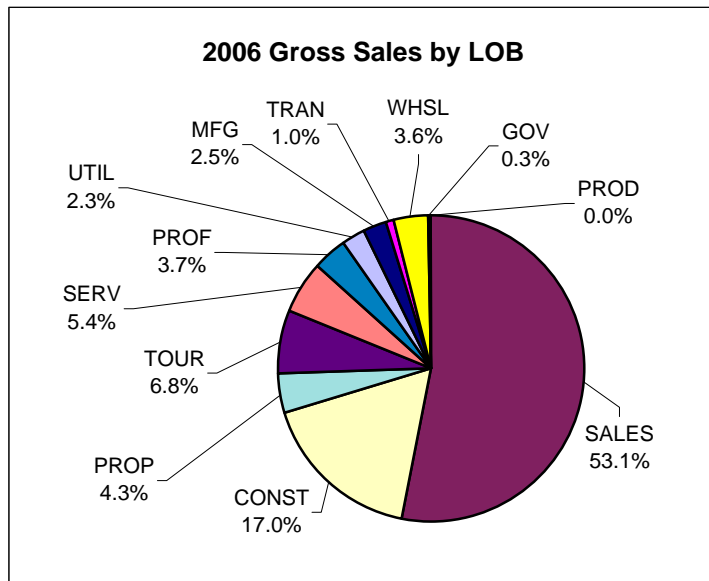

Chart 6.17

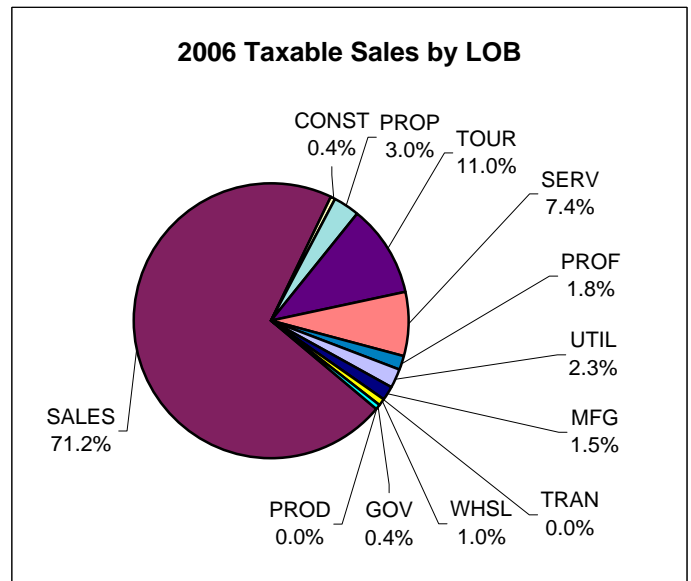

Chart 6.18

Soldotna TAXABLE Sales by Line of Business by Quarter - 2006 - in \$					
LOB	1st Quarter	2nd Quarter	3rd Quarter	4th Quarter	Total
Resource Production	1,990	14,023	12,868	5,446	34,327
Sales	28,494,919	38,817,334	55,303,929	39,439,020	162,055,202
Construction	209,813	253,076	228,897	247,023	938,809
Property	1,548,720	1,609,694	1,927,002	1,739,613	6,825,029
Tourism	4,303,975	6,787,726	9,232,083	4,742,818	25,066,602
Services	3,625,907	4,222,088	4,644,232	4,302,309	16,794,536
Professional	1,066,415	1,159,056	924,702	863,607	4,013,780
Utility	1,621,254	1,109,739	933,992	1,504,841	5,169,826
Manufacturing	527,827	714,499	1,520,449	643,127	3,405,902
Transporation & Warehousing	29,206	21,151	27,940	25,948	104,245
Wholesale	472,520	498,696	514,660	692,442	2,178,318
Government	215,019	231,090	286,966	225,376	958,451
TOTAL	42,117,565	55,438,172	75,557,720	54,431,570	227,545,027

Table 6.24

Soldotna Sales

Soldotna Annual Gross Sales by Quarter - in \$						
	1st Quarter	2nd Quarter	3rd Quarter	4th Quarter	Total	Annual Change
1994	38,984,366	40,701,206	42,085,039	45,570,593	167,341,204	
1995	40,627,047	53,363,505	64,724,383	54,057,905	212,772,840	27.1%
1996	44,155,649	54,086,799	66,745,597	53,262,403	218,250,448	2.6%
1997	43,136,587	56,048,000	71,982,003	61,417,298	232,583,888	6.6%
1998	46,245,330	61,860,448	76,091,735	66,596,151	250,793,664	7.8%
1999	51,429,980	67,872,794	87,697,762	70,577,461	277,577,997	10.7%
2000	55,201,896	72,515,215	89,530,301	72,007,899	289,255,311	4.2%
2001	60,802,277	75,042,511	95,670,432	77,603,011	309,118,231	6.9%
2002	62,331,750	79,762,672	103,625,416	80,180,782	325,900,620	5.4%
2003	64,254,952	85,227,616	106,268,314	82,155,118	337,906,000	3.7%
2004	69,929,668	89,310,129	107,196,637	94,822,445	361,258,879	6.9%
2005	65,958,153	87,630,570	113,939,869	128,504,871	396,033,463	9.6%
2006	72,457,151	99,012,814	121,167,794	140,217,422	432,855,181	9.3%
2007	79,259,451	102,966,180	130,199,945	116,869,811	429,295,387	-0.8%
2008	92,564,635	116,351,254	151,670,076	116,991,515	477,577,480	11.2%
2009	80,144,384	106,770,323			186,914,707	
Change	-13.4%	-8.2%			11.2%	

Table 6.25

Soldotna Annual Taxable Sales by Quarter - in \$						
	1st Quarter	2nd Quarter	3rd Quarter	4th Quarter	Total	Annual Change
1994	19,531,203	31,266,887	38,337,634	30,566,757	119,702,481	
1995	23,569,520	32,168,958	41,181,901	32,127,968	129,048,347	7.8%
1996	26,114,766	32,996,657	41,676,112	32,537,647	133,325,182	3.3%
1997	26,296,124	33,910,547	44,323,596	35,806,409	140,336,676	5.3%
1998	27,184,841	37,240,899	46,529,812	36,834,109	147,789,661	5.3%
1999	28,439,928	38,203,092	50,494,117	38,804,887	155,942,024	5.5%
2000	29,664,420	38,766,616	50,523,183	40,481,909	159,436,128	2.2%
2001	32,492,377	42,914,074	54,143,248	42,868,739	172,418,438	8.1%
2002	33,736,608	43,504,958	57,489,123	42,248,703	176,979,392	2.6%
2003	34,464,122	47,026,039	62,579,271	46,558,340	190,627,772	7.7%
2004	37,385,342	49,011,743	66,181,487	47,480,976	200,059,548	4.9%
2005	38,716,680	52,146,002	69,952,376	50,395,386	211,210,444	5.6%
2006	42,117,565	55,438,172	75,557,720	54,431,570	227,545,027	7.7%
2007	45,881,620	59,407,136	80,093,167	58,113,298	243,495,221	7.0%
2008	50,599,332	66,997,553	95,900,218	59,587,854	273,084,957	12.2%
2009	46,959,852	60,516,853			107,476,705	
Change	-7.2%	-9.7%	19.7%	2.5%	12.2%	

Table 6.26

Soldotna Annual Non-Taxable Sales by Quarter - in \$						
	1st Quarter	2nd Quarter	3rd Quarter	4th Quarter	Total	Annual Change
1994	19,453,163	9,434,319	3,747,405	15,003,836	47,638,723	
1995	17,057,527	21,194,547	23,542,482	21,929,937	83,724,493	75.7%
1996	18,040,883	21,090,142	25,069,485	20,724,756	84,925,266	1.4%
1997	16,840,463	22,137,453	27,658,407	25,610,889	92,247,212	8.6%
1998	19,060,489	24,619,549	29,561,923	29,762,042	103,004,003	11.7%
1999	22,990,052	29,669,702	37,203,645	31,772,574	121,635,973	18.1%
2000	25,537,476	33,748,599	39,007,118	31,525,990	129,819,183	6.7%
2001	28,309,900	32,128,437	41,527,184	34,734,272	136,699,793	5.3%
2002	28,595,142	36,257,714	46,136,293	37,932,079	148,921,228	8.9%
2003	29,790,830	38,201,577	43,689,043	35,596,778	147,278,228	-1.1%
2004	32,544,326	40,298,386	41,015,150	47,341,469	161,199,331	9.5%
2005	27,241,473	35,484,568	43,987,493	78,109,485	184,823,019	14.7%
2006	30,339,586	43,574,642	45,610,074	85,785,852	205,310,154	11.1%
2007	33,377,831	43,559,044	50,106,778	58,756,513	185,800,166	-9.5%
2008	41,965,303	49,353,701	55,769,858	57,403,661	204,492,523	10.1%
2009	33,184,532	46,253,470				
Change	-20.9%	-6.3%	11.3%	-2.3%	10.1%	

Table 6.27

Soldotna Construction

Soldotna 2nd Quarter Permit VALUES by Type - 2003-2009- in \$								
	2003	2004	2005	2006	2007	2008	2009	Annual Change
Residential New	1,899,354	1,777,087	1,916,999	2,116,499	6,083,538	3,273,346	3,861,545	18.0%
Residential Alter/Add	130,080	74,809	141,950	140,730	224,588	173,875	221,185	27.2%
Commercial New	2,116,490	1,366,297	4,099,828	4,965,648	1,461,142	832,900	138,790	-83.3%
Commercial Alter/Add	88,000	530,380	673,458	8,451	107,937	932,000	1,073,356	15.2%
Total	4,233,924	3,748,573	6,832,235	7,231,328	7,877,205	5,212,121	5,294,876	1.6%
Annual Change		-11.5%	82.3%	5.8%	8.9%	-33.8%	1.6%	

Table 6.28

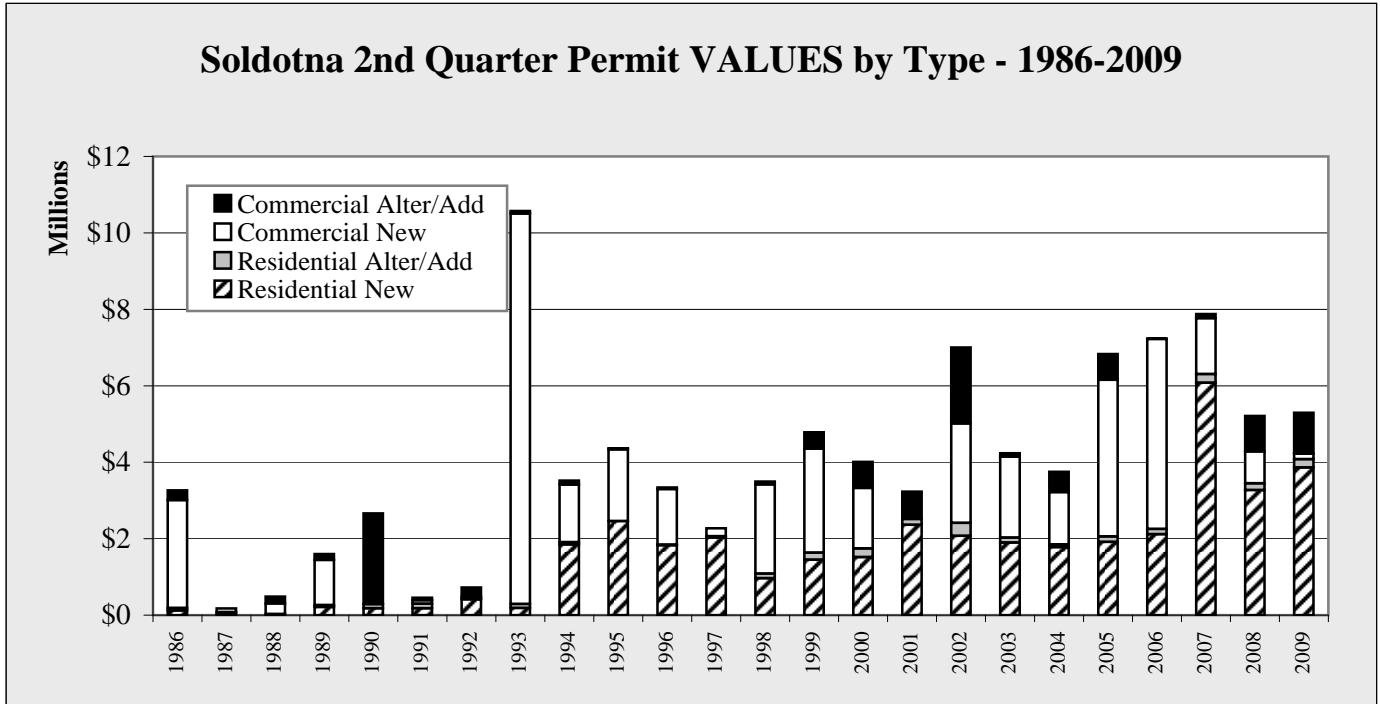

Chart 6.19

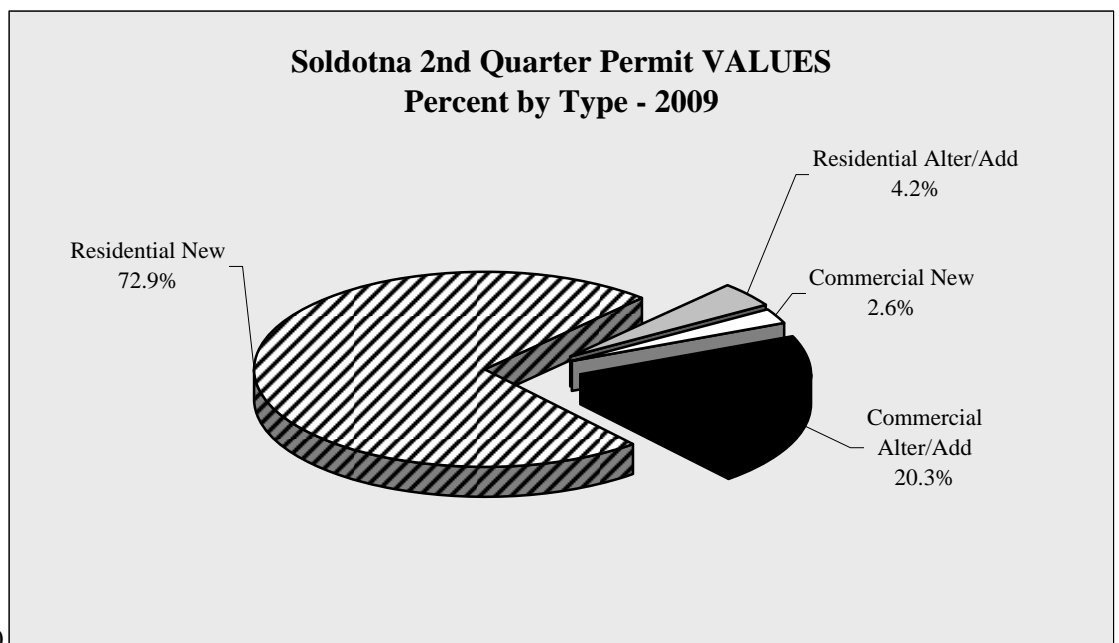

Chart 6.20

Soldotna Construction

Soldotna 2nd Quarter Permit VOLUME by Type - 2003-2009								
	2003	2004	2005	2006	2007	2008	2009	Annual Change
Residential New	15	9	11	13	16	10	18	80.0%
Residential Alter/Add	8	8	12	6	5	17	12	-29.4%
Commercial New	6	3	9	5	5	3	1	-66.7%
Commercial Alter/Add	7	6	8	1	7	15	11	-26.7%
Total	36	26	40	25	33	45	42	-6.7%
Annual Change		-27.8%	53.8%	-37.5%	32.0%	36.4%	-6.7%	

Table 6.29

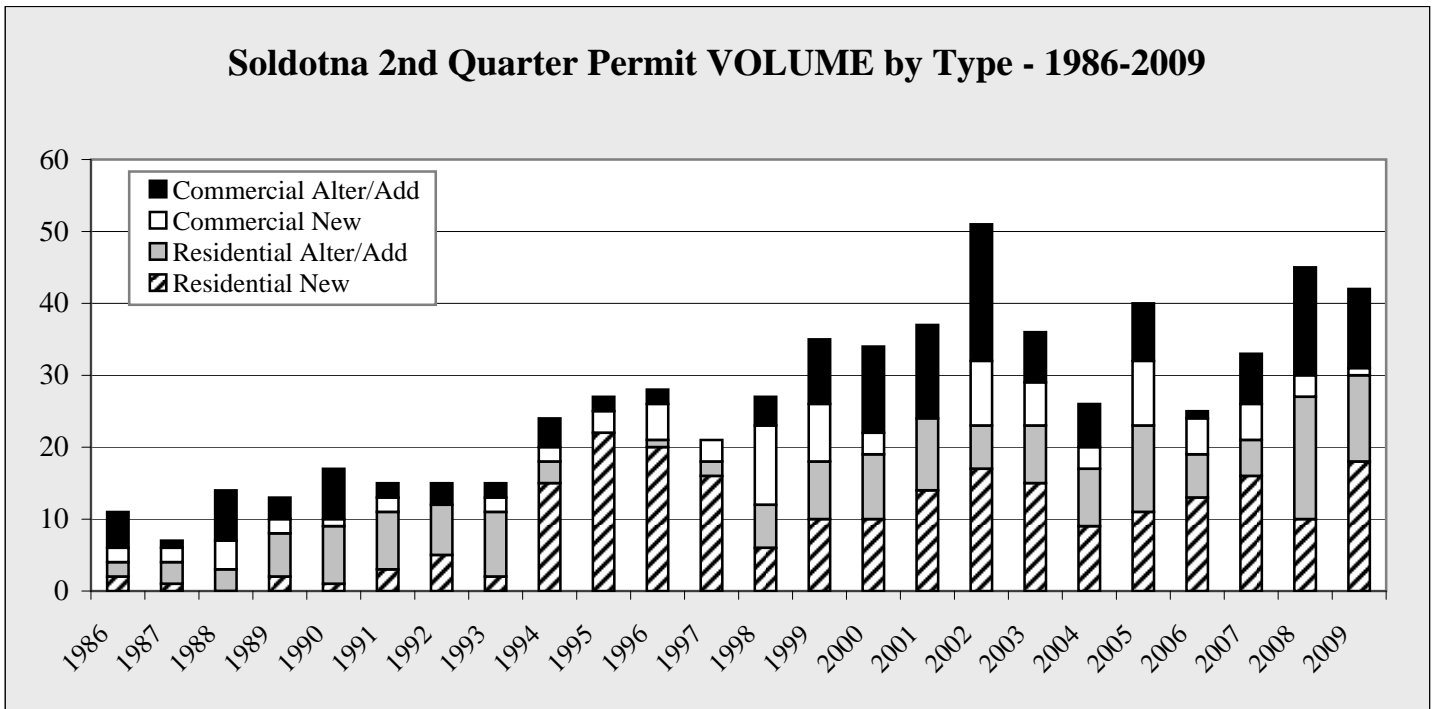

Chart 6.21

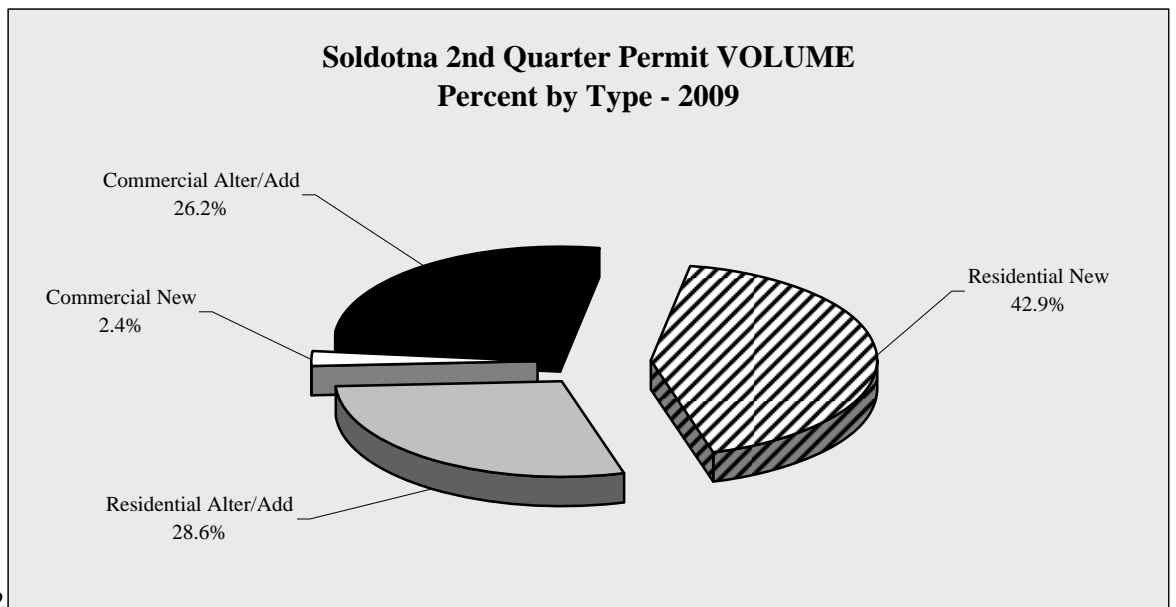

Chart 6.22

Soldotna Construction

Soldotna YTD 6/30 Permit VALUES by Type - 2003-2009 - in \$								
	2003	2004	2005	2006	2007	2008	2009	Annual Change
Residential New	1,899,354	2,316,384	2,637,955	2,320,530	6,619,260	3,720,623	4,061,545	9.2%
Residential Alter/Add	187,907	74,809	403,580	150,730	374,137	228,171	259,185	13.6%
Commercial New	2,116,490	5,831,323	4,294,828	5,278,058	1,461,142	2,397,637	138,790	-94.2%
Commercial Alter/Add	457,191	590,380	917,427	1,598,451	250,437	1,271,943	1,288,356	1.3%
Total	4,660,942	8,812,896	8,253,790	9,347,769	8,704,976	7,618,374	5,747,876	-24.6%
Annual Change		89.1%	-6.3%	13.3%	-6.9%	-12.5%	-24.6%	

Table 6.30

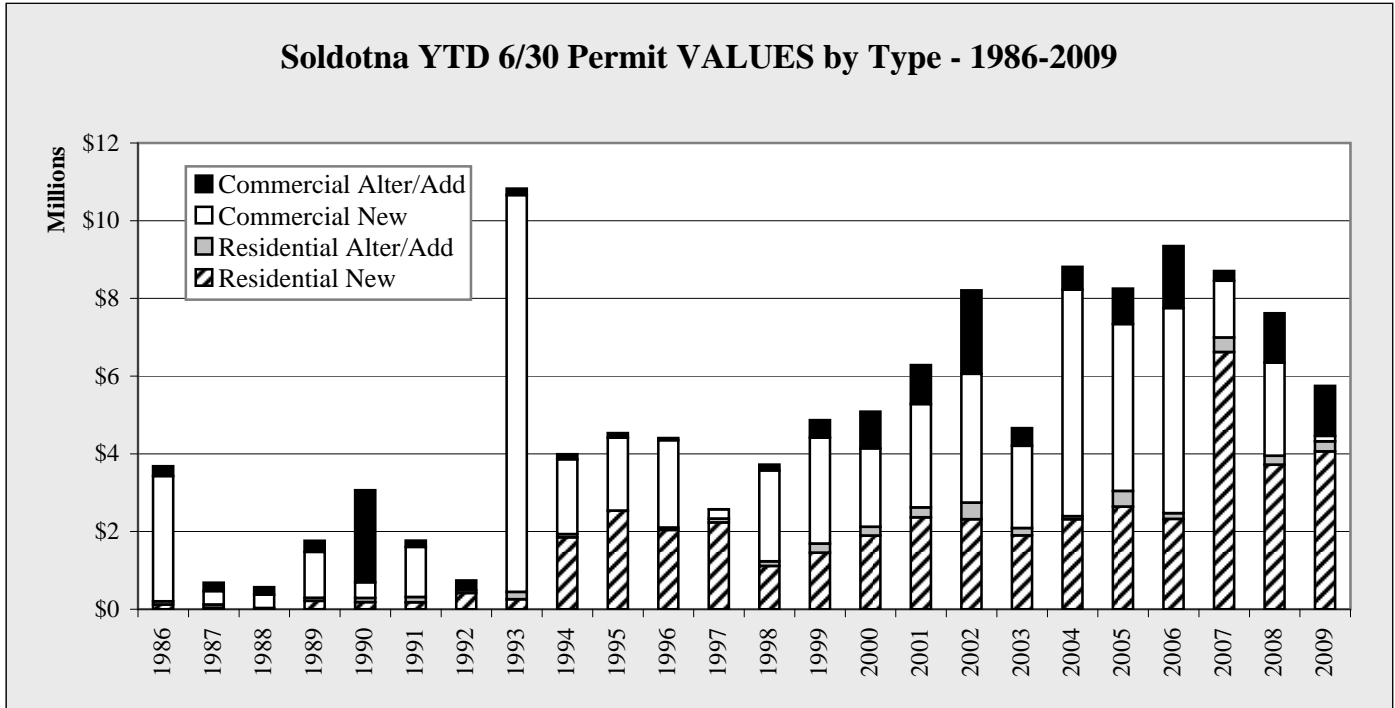

Chart 6.23

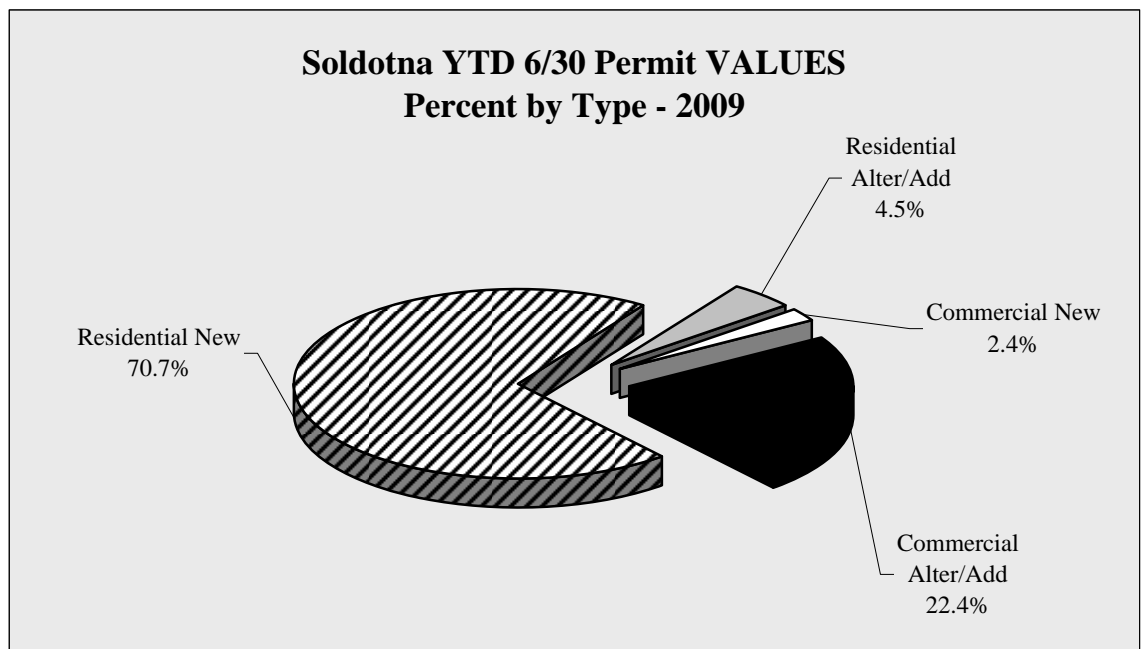

Chart 6.24

Soldotna Construction

Soldotna YTD 6/30 Permit VOLUME by Type - 2003-2009								
	2003	2004	2005	2006	2007	2008	2009	Annual Change
Residential New	15	11	15	14	18	22	19	-13.6%
Residential Alter/Add	11	8	15	7	7	10	7	-30.0%
Commercial New	6	7	11	6	5	8	1	-87.5%
Commercial Alter/Add	10	9	FALSE	3	12	18	16	-11.1%
Total	42	35	41	30	42	58	43	-25.9%
Annual Change		-16.7%	17.1%	-26.8%	40.0%	38.1%	-25.9%	

Table 6.31

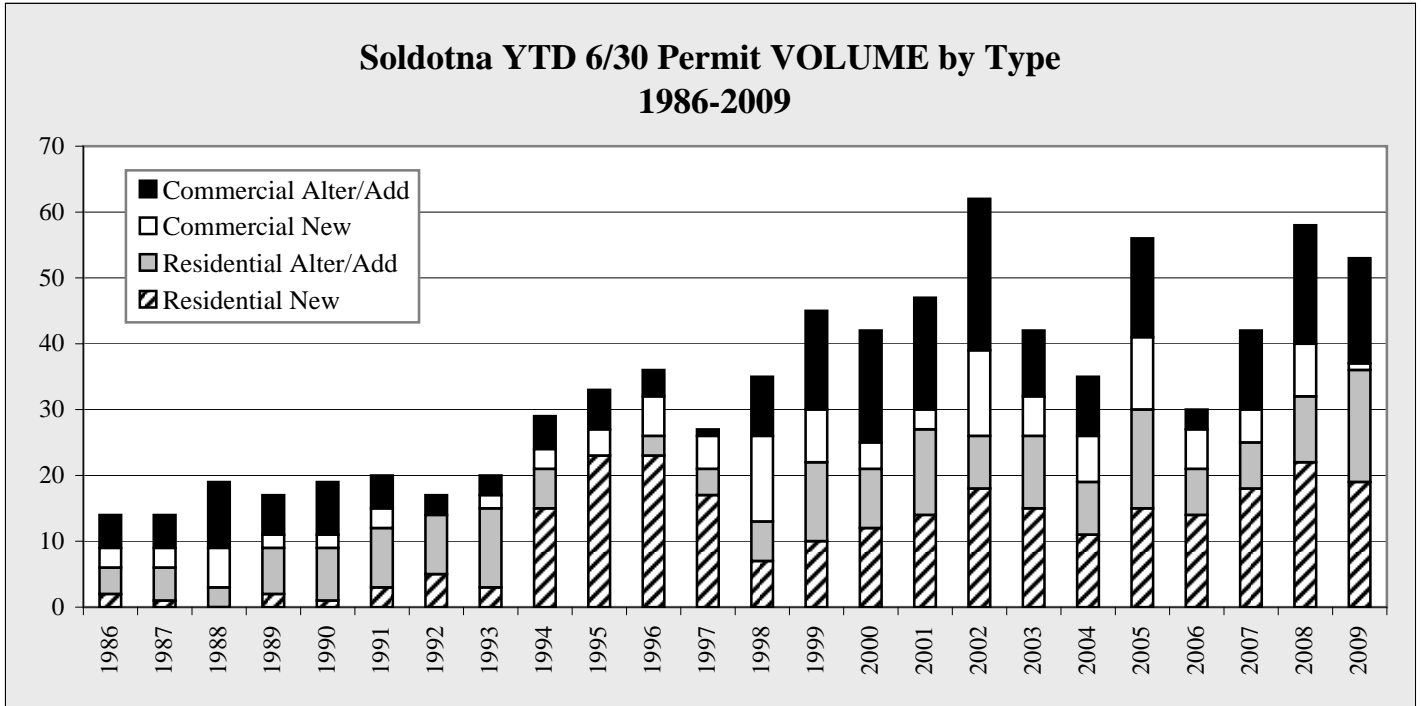

Chart 6.25

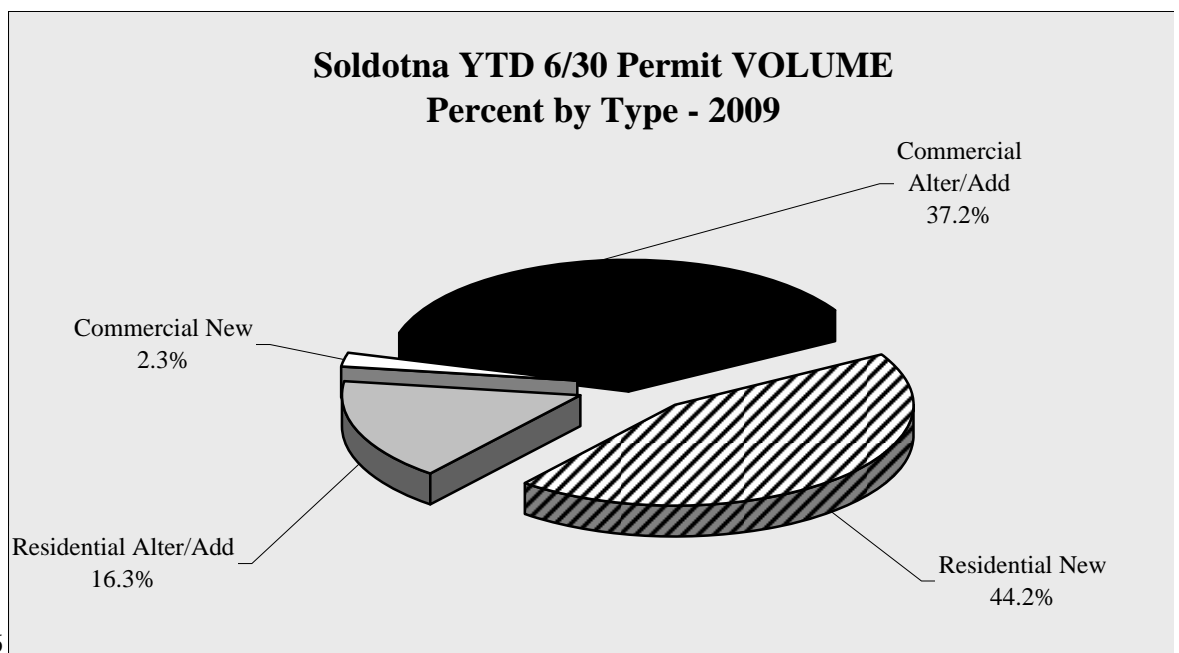

Chart 6.26

Soldotna Construction

Soldotna Annual Permit VALUES by Type by Quarter - 2002-2009 - in \$					
	1st Quarter	2nd Quarter	3rd Quarter	4th Quarter	Total
2002					
Residential - New	240,849	2,075,293	689,202	176,000	3,181,344
Residential - Add/Alter	86,935	339,286	317,466	11,500	755,187
Commercial - New	714,806	2,601,575	1,080,678	0	4,397,059
Commercial - Add/Alter	163,000	1,987,304	610,000	70,000	2,830,304
TOTAL	1,205,590	7,003,458	2,697,346	257,500	11,163,894
2003					
Residential - New	0	1,899,354	648,388	526,191	3,073,933
Residential - Add/Alter	57,827	130,080	70,722	5,000	263,629
Commercial - New	0	2,116,490	1,371,200	281,491	3,769,181
Commercial - Add/Alter	369,191	88,000	328,000	60,363	845,554
TOTAL	427,018	4,233,924	2,418,310	873,045	7,952,297
2004					
Residential - New	539,297	1,777,087	1,270,100	294,860	3,881,344
Residential - Add/Alter	0	74,809	145,721	57,454	277,984
Commercial - New	4,465,026	1,366,297	21,996,101	501,601	28,329,025
Commercial - Add/Alter	60,000	530,380	368,193	3,850,000	4,808,573
TOTAL	5,064,323	3,748,573	23,780,115	4,703,915	37,296,926
2005					
Residential - New	720,956	1,916,999	1,295,670	165,123	4,098,748
Residential - Add/Alter	261,630	141,950	88,410	2,000	493,990
Commercial - New	195,000	4,099,828	1,520,000	0	5,814,828
Commercial - Add/Alter	243,969	673,458	181,650	2,717	1,101,794
TOTAL	1,421,555	6,832,235	3,085,730	169,840	11,509,360
2006					
Residential - New	204,031	2,116,499	5,106,077	172,833	7,599,440
Residential - Add/Alter	10,000	140,730	368,788	262,659	782,177
Commercial - New	312,410	4,965,648	7,646,794	0	12,924,852
Commercial - Add/Alter	1,590,000	8,451	92,090	197,390	1,887,931
TOTAL	2,116,441	7,231,328	13,213,749	632,882	23,194,400
2007					
Residential - New	535,722	6,083,538	2,042,153	88,000	8,749,413
Residential - Add/Alter	149,549	224,588	110,638	248,665	733,440
Commercial - New	-	1,461,142	546,300	1,654,112	3,661,554
Commercial - Add/Alter	142,500	107,937	66,811	301,268	618,516
TOTAL	827,771	7,877,205	2,765,902	2,292,045	13,762,923
2008					
Residential - New	447,277	3,273,346	597,140	8,000	4,325,763
Residential - Add/Alter	54,296	173,875	426,638	5,000	659,809
Commercial - New	1,464,737	932,900	10,645,283	176,146	13,219,066
Commercial - Add/Alter	339,943	932,000	41,600	75,000	1,388,543
TOTAL	2,306,253	5,312,121	11,710,661	264,146	19,593,181
2009 YTD					
Residential - New	200,000	3,861,545			4,061,545
Residential - Add/Alter	38,000	221,185			259,185
Commercial - New	0	138,790			138,790
Commercial - Add/Alter	215,000	1,073,356			1,288,356
TOTAL	453,000	5,294,876	0	0	5,747,876

Table 6.32

Soldotna Construction

Soldotna Annual Permit VOLUME by Type by Quarter - 2002-2009					
	1st Quarter	2nd Quarter	3rd Quarter	4th Quarter	Total
2002					
Residential - New	1	17	5	1	24
Residential - Add/Alter	2	6	10	2	20
Commercial - New	4	9	5	0	18
Commercial - Add/Alter	4	19	5	1	29
TOTAL	11	51	25	4	91
2003					
Residential - New	0	15	4	5	24
Residential - Add/Alter	3	8	4	1	16
Commercial - New	0	6	8	2	16
Commercial - Add/Alter	3	7	3	5	18
TOTAL	6	36	19	13	74
2004					
Residential - New	2	9	7	1	19
Residential - Add/Alter	0	8	6	3	17
Commercial - New	4	3	4	2	13
Commercial - Add/Alter	3	6	7	2	18
TOTAL	9	26	24	8	67
2005					
Residential - New	4	11	7	1	23
Residential - Add/Alter	3	12	7	1	23
Commercial - New	2	9	2	0	13
Commercial - Add/Alter	7	8	4	3	22
TOTAL	16	40	20	5	81
2006					
Residential - New	1	13	14	1	29
Residential - Add/Alter	1	6	5	3	15
Commercial - New	1	5	3	0	9
Commercial - Add/Alter	2	1	5	3	11
TOTAL	5	25	27	7	64
2007					
Residential - New	2	16	10	2	30
Residential - Add/Alter	2	5	5	6	18
Commercial - New	0	5	2	4	11
Commercial - Add/Alter	5	7	5	4	21
TOTAL	9	33	22	16	80
2008					
Residential - New	3	19	2	1	25
Residential - Add/Alter	3	7	15	1	26
Commercial - New	5	3	6	1	15
Commercial - Add/Alter	10	8	5	2	25
TOTAL	21	37	28	5	91
2009					YTD
Residential - New	1	18			19
Residential - Add/Alter	5	12			17
Commercial - New	0	1			1
Commercial - Add/Alter	5	11			16
TOTAL	11	42	0	0	53

Table 6.33

OTHER KBP

Other KPB Sales

Other KPB Second Quarter GROSS Sales by Line of Business - 2004-2009- in \$								
LOB	2004	2005	2006	2007	2008	2009	Annual Percent Change	Annual Amount Change
PROD	27,224,407	32,984,277	42,117,493	33,892,210	33,080,374	31,187,936	-5.7%	-1,892,438
SALES	38,901,167	41,797,052	45,018,503	46,880,348	51,980,833	46,385,788	-10.8%	-5,595,045
CONST	20,446,499	26,551,092	27,220,505	37,397,784	31,838,817	38,928,009	22.3%	7,089,192
PROP	5,468,527	6,518,043	7,711,054	8,174,597	8,408,459	8,409,588	0.0%	1,129
TOUR	13,748,725	14,032,029	16,422,541	16,289,601	21,073,270	15,576,145	-26.1%	-5,497,125
SERV	12,174,399	15,118,937	17,352,850	21,575,358	29,435,249	28,307,461	-3.8%	-1,127,788
PROF	4,311,442	3,829,282	4,645,860	5,367,286	7,835,377	6,087,818	-22.3%	-1,747,559
UTIL	8,705,618	9,588,169	10,777,719	12,163,387	12,833,201	15,346,728	19.6%	2,513,527
MANU	4,876,124	46,385,401	41,596,930	29,695,712	64,537,243	14,148,692	-78.1%	-50,388,551
TRAN	15,985,223	16,387,525	16,377,656	12,608,118	8,126,006	6,621,102	-18.5%	-1,504,904
WHLS	35,659,336	28,340,752	32,313,057	29,203,206	40,939,315	31,553,391	-22.9%	-9,385,924
GOV	0	53,661	30,523	7,764	16,321	48,630	198.0%	32,309
TOTAL	187,501,467	241,586,220	261,584,691	253,255,371	310,104,465	242,601,288	-21.8%	-67,503,177

Table 7.1

For complete listing of Lines of Business, see page 17

Other KPB Second Quarter GROSS Sales History	
2004	187,501,467
2005	241,586,220
2006	261,584,691
2007	253,255,371
2008	310,104,465
2009	242,601,288

Table 7.2

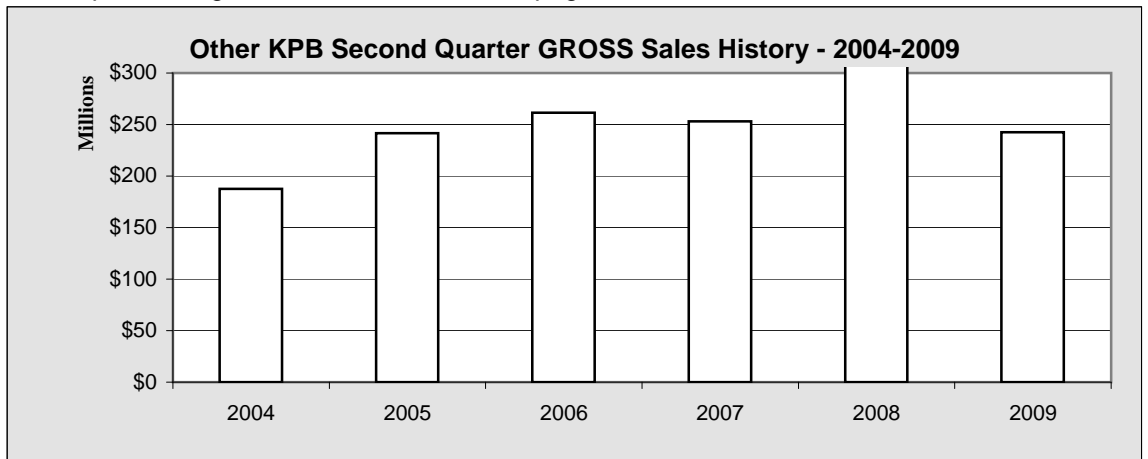

Chart 7.1

Other KPB Five Year Change Second Quarter TAXABLE Sales		
LOB	2004	2009
PROD	27,224,407	31,187,936
SALES	38,901,167	46,385,788
CONST	20,446,499	38,928,009
PROP	5,468,527	8,409,588
TOUR	13,748,725	15,576,145
SERV	12,174,399	28,307,461
PROF	4,311,442	6,087,818
UTIL	8,705,618	15,346,728
MANU	4,876,124	14,148,692
TRAN	15,985,223	6,621,102
WHLS	35,659,336	31,553,391
GOV	0	48,630
TOTAL	187,501,467	242,601,288

Table 7.3

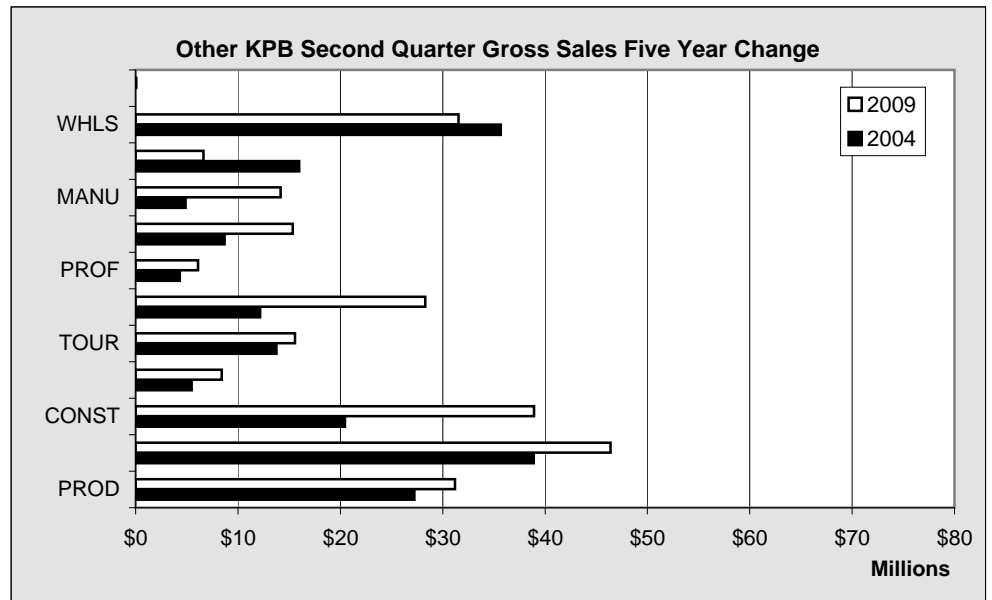

Chart 7.2

Other KPB Sales

Other KPB Second Quarter TAXABLE Sales by Line of Business-2004-2009- in \$								
LOB	2004	2005	2006	2007	2008	2009	Annual Percent Change	Annual Amount Change
PROD	1,574,246	1,603,774	1,618,533	1,831,597	1,939,300	2,344,035	20.9%	404,735
SALES	19,104,918	19,210,896	20,884,708	22,168,548	26,163,244	6,967,318	-73.4%	-19,195,926
CONST	1,842,907	1,877,577	1,941,560	2,028,713	1,999,973	1,690,078	-15.5%	-309,895
PROP	2,275,448	2,377,591	2,822,743	3,196,150	3,474,005	2,971,392	-14.5%	-502,613
TOUR	11,771,684	12,094,385	13,606,164	14,681,098	18,479,839	13,293,950	-28.1%	-5,185,889
SERV	6,786,140	8,316,241	9,140,307	9,969,600	11,747,596	11,623,560	-1.1%	-124,036
PROF	1,102,766	1,140,272	1,242,207	1,361,222	1,444,504	1,247,072	-13.7%	-197,432
UTIL	4,969,149	5,915,426	6,739,938	7,552,563	8,221,322	9,625,962	17.1%	1,404,640
MANU	704,656	885,842	849,472	1,032,150	940,643	913,507	-2.9%	-27,136
TRAN	4,003,076	4,814,809	3,320,732	5,145,046	269,454	265,519	-1.5%	-3,935
WHLS	4,293,154	5,020,486	6,165,135	6,331,399	7,678,214	6,476,637	-15.6%	-1,201,577
GOV	0	4,448	3,279	3,500	8,551	12,563	46.9%	4,012
TOTAL	58,428,144	63,261,747	68,334,778	75,301,586	82,366,645	57,431,593	-30.3%	-24,935,052

Table 7.4

For complete listing of Lines of Business, see page 17

Other KPB Second Quarter TAXABLE Sales History	
2004	58,428,144
2005	63,261,747
2006	68,334,778
2007	75,301,586
2008	82,366,645
2009	57,431,593

Table 7.5

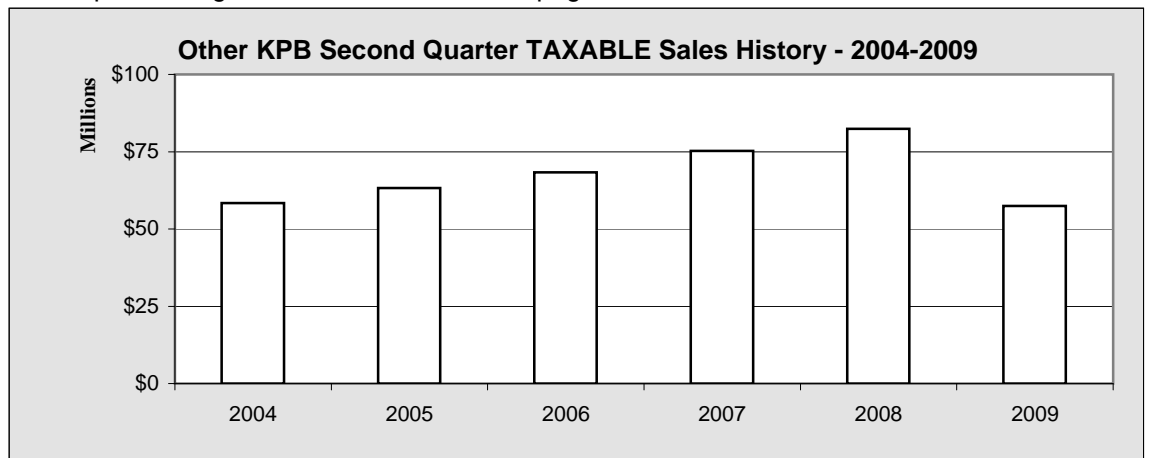

Chart 7.3

Other KPB Five Year Change Second Quarter TAXABLE Sales		
LOB	2004	2009
PROD	1,574,246	2,344,035
SALES	19,104,918	6,967,318
CONST	1,842,907	1,690,078
PROP	2,275,448	2,971,392
TOUR	11,771,684	13,293,950
SERV	6,786,140	11,623,560
PROF	1,102,766	1,247,072
UTIL	4,969,149	9,625,962
MANU	704,656	913,507
TRAN	4,003,076	265,519
WHLS	4,293,154	6,476,637
GOV	0	12,563
TOTAL	58,428,144	57,431,593

Table 7.6

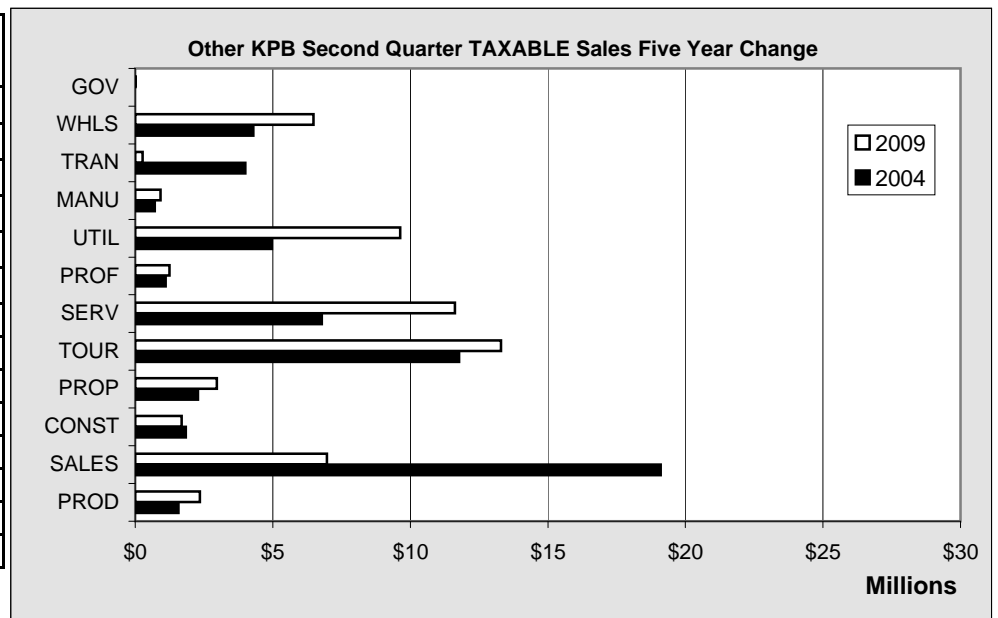

Chart 7.4

Other KPB Sales

Other KPB YTD June 30 GROSS Sales by Line of Business - 2004-2009 - in \$

LOB	2004	2005	2006	2007	2008	2009	Annual Percent Change	Annual Amount Change
PROD	62,726,146	69,522,683	82,337,773	58,065,639	55,213,979	61,731,855	11.8%	6,517,876
SALES	62,661,563	65,713,422	71,447,588	77,869,551	84,537,244	76,642,655	-9.3%	-7,894,589
CONST	33,657,662	45,057,111	44,959,306	62,129,258	57,117,526	63,112,827	10.5%	5,995,301
PROP	10,412,956	10,800,031	12,964,784	14,181,448	13,959,449	15,793,491	13.1%	1,834,042
TOUR	17,402,675	17,741,898	20,831,358	21,904,408	24,018,311	18,152,675	-24.4%	-5,865,636
SERV	22,152,724	27,489,955	31,631,566	38,663,870	51,828,664	53,229,854	2.7%	1,401,190
PROF	7,945,137	7,470,708	8,956,165	10,267,993	13,016,201	10,969,536	-15.7%	-2,046,665
UTIL	18,153,979	21,583,146	24,982,598	29,134,017	28,572,729	38,267,795	33.9%	9,695,066
MANU	22,714,299	73,084,507	55,693,803	66,276,318	92,464,108	39,517,799	-57.3%	-52,946,309
TRAN	24,342,092	24,399,468	22,519,372	17,266,027	13,219,228	12,721,779	-3.8%	-497,449
WHLS	64,498,220	61,541,596	57,675,580	54,548,417	73,439,681	146,903,134	100.0%	73,463,453
GOV	6,365	226,615	147,438	32,891	320,297	388,150	21.2%	67,853
TOTAL	346,673,818	424,631,140	434,147,331	450,339,837	507,707,417	537,431,550	5.9%	29,724,133

Table 7.7

For complete listing of Lines of Business, see page 17

Other KPB YTD June 30 GROSS Sales History	
2004	346,673,818
2005	424,631,140
2006	434,147,331
2007	450,339,837
2008	507,707,417
2009	537,431,550

Table 7.8

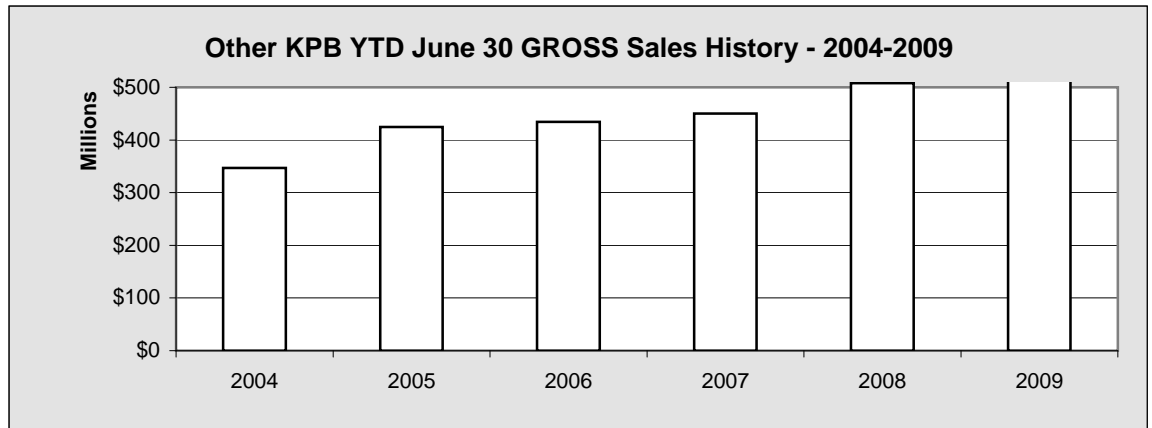

Chart 7.5

Other KPB Five Year Change YTD June 30 GROSS Sales		
	2004	2009
PROD	62,726,146	61,731,855
SALES	62,661,563	76,642,655
CONST	33,657,662	63,112,827
PROP	10,412,956	15,793,491
TOUR	17,402,675	18,152,675
SERV	22,152,724	53,229,854
PROF	7,945,137	10,969,536
UTIL	18,153,979	38,267,795
MANU	22,714,299	39,517,799
TRAN	24,342,092	12,721,779
WHLS	64,498,220	146,903,134
GOV	6,365	388,150
TOTAL	346,673,818	537,431,550

Table 7.9

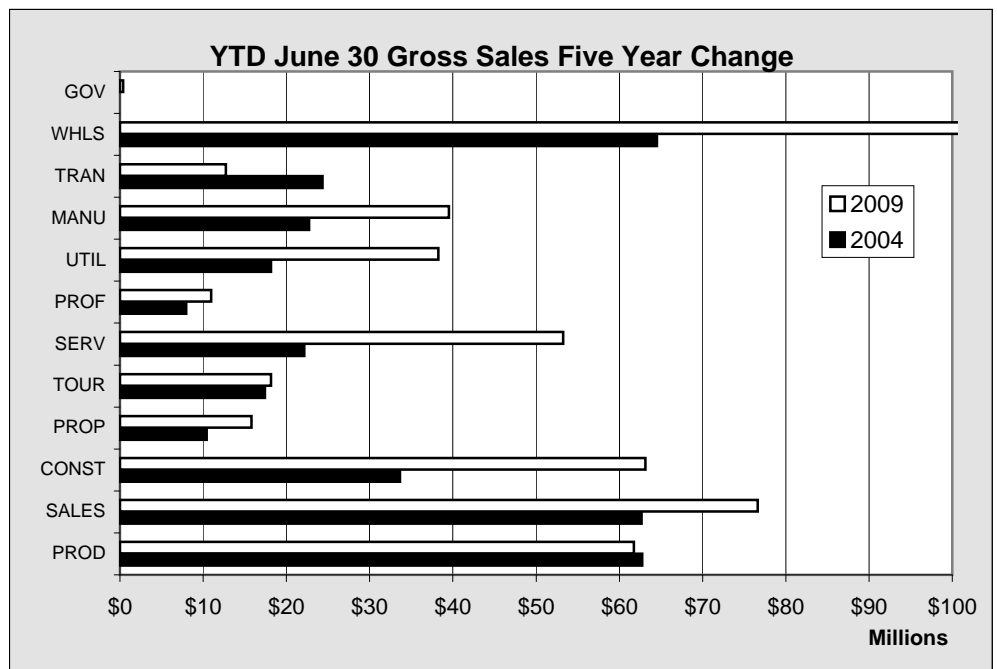

Chart 7.6

Other KPB Sales

Other KPB YTD June 30 TAXABLE Sales by Line of Business - 2004-2009 - in \$								
LOB	2004	2005	2006	2007	2008	2009	Annual Percent Change	Annual Amount Change
PROD	2,463,722	2,497,849	2,436,473	2,682,410	2,851,969	3,408,718	19.5%	556,749
SALES	31,657,536	31,078,402	34,065,634	35,777,328	42,141,782	8,865,796	-79.0%	-33,275,986
CONST	3,177,754	3,034,012	3,138,242	3,409,519	3,495,893	2,933,221	-16.1%	-562,672
PROP	4,141,884	4,191,517	4,894,193	5,447,413	5,921,824	5,322,014	-10.1%	-599,810
TOUR	15,177,896	15,581,396	17,558,691	18,724,946	21,116,397	15,384,173	-27.1%	-5,732,224
SERV	12,507,099	15,306,627	16,404,550	17,746,043	21,364,138	21,850,760	2.3%	486,622
PROF	2,075,229	2,131,724	2,348,027	2,524,319	2,580,571	2,317,681	-10.2%	-262,890
UTIL	11,741,578	13,636,825	16,329,890	18,919,125	18,934,628	25,103,725	32.6%	6,169,097
MANU	1,023,585	1,257,200	1,231,287	1,436,099	1,348,408	1,258,685	-6.7%	-89,723
TRAN	4,440,612	5,261,018	3,501,258	5,299,518	441,622	466,203	5.6%	24,581
WHLS	9,092,402	10,393,274	12,384,913	13,386,548	15,429,626	13,290,981	-13.9%	-2,138,645
GOV	6,300	25,765	4,779	16,418	23,817	21,975	-7.7%	-1,842
TOTAL	97,505,597	104,395,609	114,297,937	125,369,686	135,650,675	100,223,932	-26.1%	-35,426,743

Table 7.10 For complete listing of Lines of Business, see page 17

Other KPB YTD June 30 TAXABLE Sales History	
2004	97,505,597
2005	104,395,609
2006	114,297,937
2007	125,369,686
2008	135,650,675
2009	100,223,932

Table 7.11

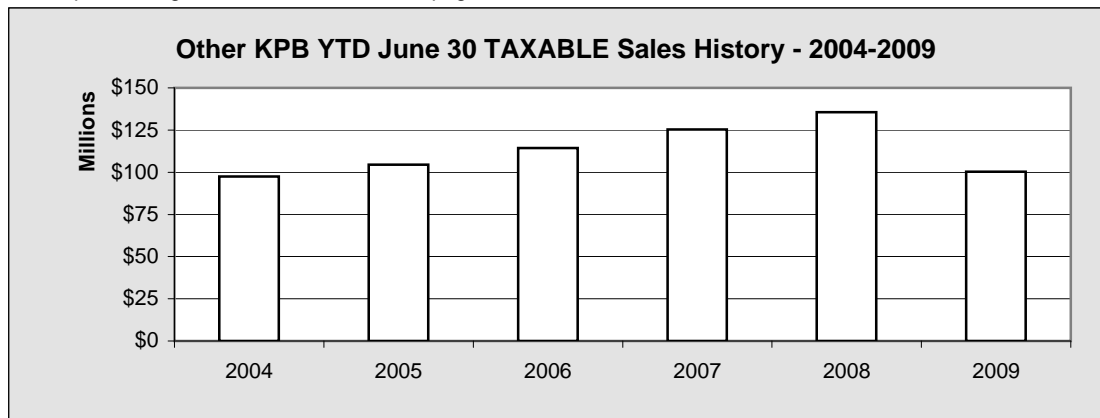

Chart 7.7

Other KPB Five Year Change YTD June 30 TAXABLE Sales		
	2004	2009
PROD	2,463,722	3,408,718
SALES	31,657,536	8,865,796
CONST	3,177,754	2,933,221
PROP	4,141,884	5,322,014
TOUR	15,177,896	15,384,173
SERV	12,507,099	21,850,760
PROF	2,075,229	2,317,681
UTIL	11,741,578	25,103,725
MANU	1,023,585	1,258,685
TRAN	4,440,612	466,203
WHLS	9,092,402	13,290,981
GOV	6,300	21,975
TOTAL	97,505,597	100,223,932

Table 7.12

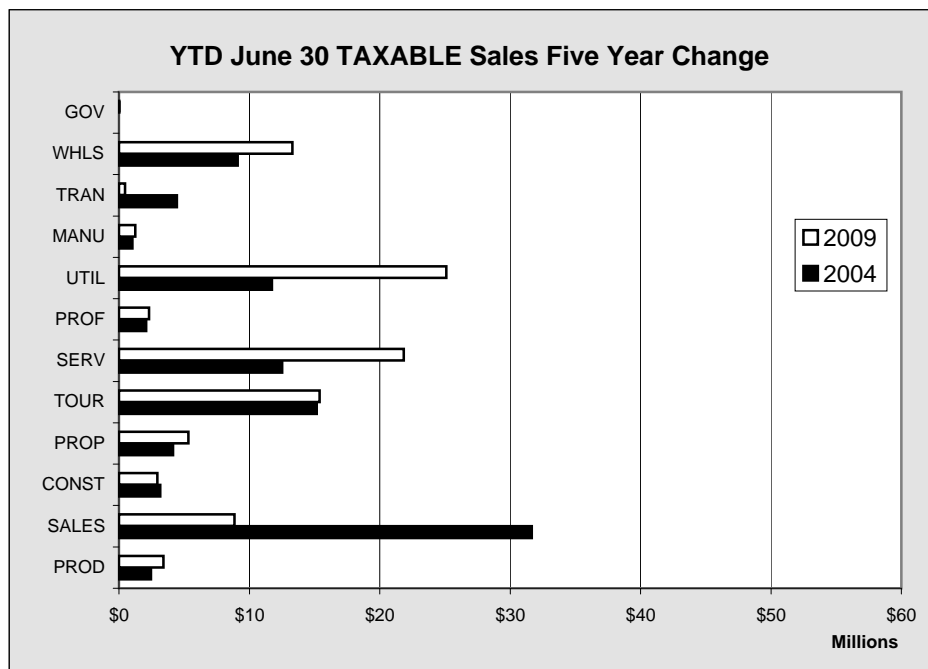

Chart 7.8

Other KPB Sales

Other KPB Annual GROSS Sales by Line of Business - 2003-2008 - in \$

LOB	2003	2004	2005	2006	2007	2008	Annual Percent Change	Annual Amount Change
PROD	174,128,291	147,140,780	153,182,362	175,123,026	148,522,424	159,516,682	7.4%	10,994,258
SALES	182,478,029	143,382,467	149,803,836	156,580,806	167,378,000	186,671,626	11.5%	19,293,626
CONST	123,133,969	121,240,100	126,832,067	154,241,220	166,892,716	149,383,384	-10.5%	-17,509,332
PROP	24,513,440	24,867,031	26,574,731	29,109,553	34,102,197	34,417,613	0.9%	315,416
TOUR	58,915,736	66,630,028	69,825,987	74,506,229	78,138,957	69,275,667	-11.3%	-8,863,290
SERV	44,239,266	63,181,724	63,766,927	70,084,535	85,664,928	114,481,526	33.6%	28,816,598
PROF	15,800,255	17,160,184	17,007,030	21,149,978	23,394,233	27,438,146	17.3%	4,043,913
UTIL	33,607,375	36,341,683	43,002,998	49,256,836	55,585,131	57,647,745	3.7%	2,062,614
MANU	85,828,471	131,419,015	187,397,786	121,518,657	126,541,825	189,882,175	50.1%	63,340,350
TRAN	16,628,065	35,308,579	36,122,095	37,924,615	26,049,567	32,818,314	26.0%	6,768,747
WHLS	102,174,522	315,068,865	330,371,937	359,368,992	385,468,249	458,484,194	18.9%	73,015,945
GOV	831,604	1,063,212	820,042	512,629	139,082	537,738	286.6%	398,656
TOTAL	862,279,023	1,102,803,668	1,204,707,798	1,249,377,076	1,297,877,309	1,480,554,810	14.1%	182,677,501

Table 7.13

For complete listing of Lines of Business, see page 17

Other KPB Annual GROSS Sales History	
2003	862,279,023
2004	1,102,803,668
2005	1,204,707,798
2006	1,249,377,076
2007	1,297,877,309
2008	1,480,554,810

Table 7.14

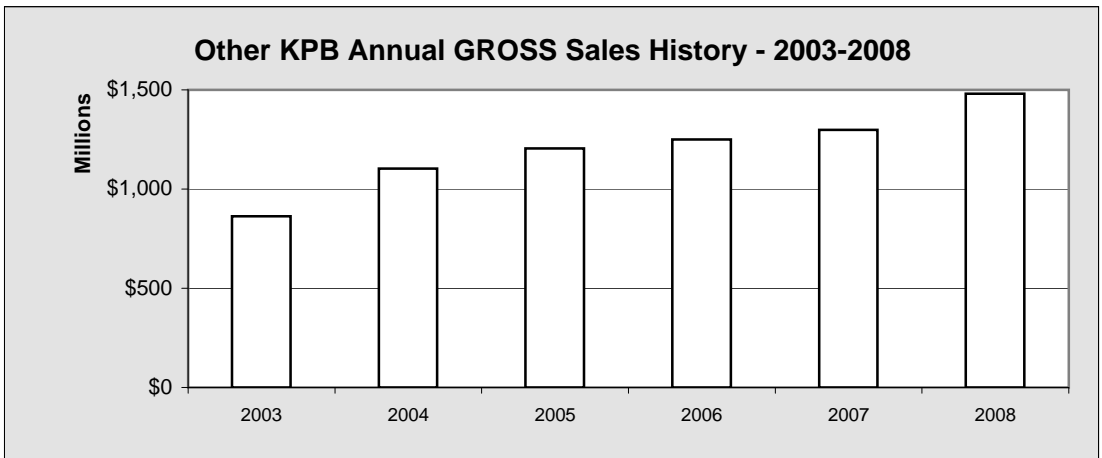

Chart 7.9

Five Year Change Annual GROSS Sales		
LOB	2003	2008
PROD	174,128,291	159,516,682
SALES	182,478,029	186,671,626
CONST	123,133,969	149,383,384
PROP	24,513,440	34,417,613
TOUR	58,915,736	69,275,667
SERV	44,239,266	114,481,526
PROF	15,800,255	27,438,146
UTIL	33,607,375	57,647,745
MANU	85,828,471	189,882,175
TRAN	16,628,065	32,818,314
WHLS	102,174,522	458,484,194
GOV	831,604	537,738
TOTAL	862,279,023	1,480,554,810

Table 7.15

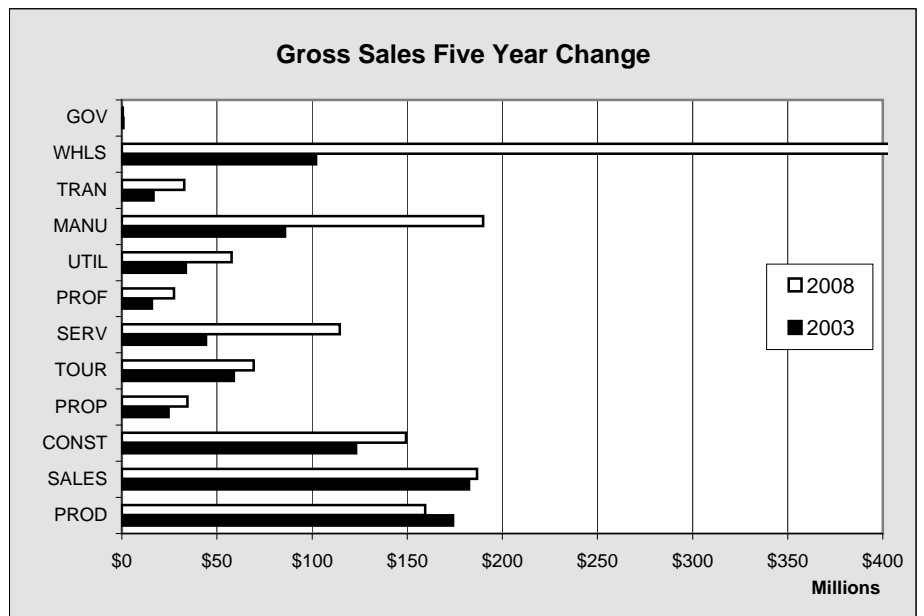

Chart 7.10

Other KPB Sales

Other KPB Annual TAXABLE Sales by Line of Business-2003-2008-in \$								
LOB	2003	2004	2005	2006	2007	2008	Annual Percent Change	Annual Amount Change
PROD	5,001,743	5,331,875	4,502,307	4,628,764	5,244,276	6,011,202	14.6%	766,926
SALES	72,262,286	68,560,411	69,150,050	75,416,814	80,153,012	94,935,337	18.4%	14,782,325
CONST	7,519,106	7,202,164	6,783,831	7,378,366	8,168,541	8,194,860	0.3%	26,319
PROP	9,331,726	9,312,213	9,995,154	11,243,745	12,556,206	13,240,502	5.4%	684,296
TOUR	44,178,366	49,103,371	51,654,969	54,875,324	66,029,697	58,673,244	-11.1%	-7,356,453
SERV	25,563,989	28,861,016	32,872,996	34,605,111	38,082,365	46,716,874	22.7%	8,634,509
PROF	4,218,877	4,399,051	4,637,341	5,106,239	5,705,529	5,517,029	-3.3%	-188,500
UTIL	22,028,897	22,822,064	26,157,508	31,333,082	34,536,924	36,976,492	7.1%	2,439,568
MANU	2,583,840	2,625,421	3,277,627	3,224,883	3,693,017	3,545,266	-4.0%	-147,751
TRAN	1,520,266	750,682	930,506	1,034,665	936,846	1,001,155	6.9%	64,309
WHLS	15,475,129	19,787,056	22,775,440	26,747,293	28,410,764	31,982,913	12.6%	3,572,149
GOV	39,501	30,667	50,936	15,303	26,808	53,750	100.5%	26,942
TOTAL	209,723,726	218,785,991	232,788,665	255,609,589	283,543,985	306,848,624	8.2%	23,304,639

Table 7.16

For complete listing of Lines of Business, see page 17

Other KPB Annual TAXABLE Sales History	
2003	209,723,726
2004	218,785,991
2005	232,788,665
2006	255,609,589
2007	283,543,985
2008	306,848,624

Table 7.17

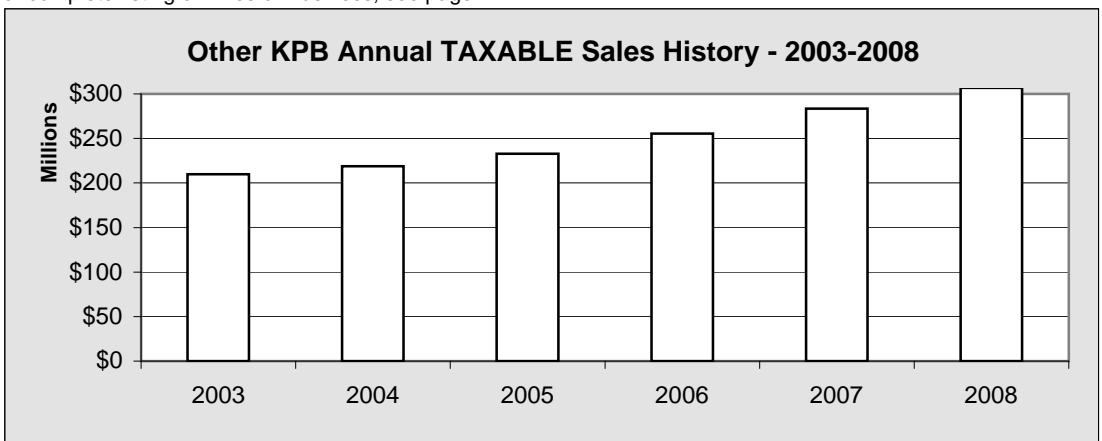

Chart 7.11

Five Year Change Annual TAXABLE Sales		
LOB	2003	2008
PROD	5,001,743	6,011,202
SALES	72,262,286	94,935,337
CONST	7,519,106	8,194,860
PROP	9,331,726	13,240,502
TOUR	44,178,366	58,673,244
SERV	25,563,989	46,716,874
PROF	4,218,877	5,517,029
UTIL	22,028,897	36,976,492
MANU	2,583,840	3,545,266
TRAN	1,520,266	1,001,155
WHLS	15,475,129	31,982,913
GOV	39,501	53,750
TOTAL	209,723,726	306,848,624

Table 7.18

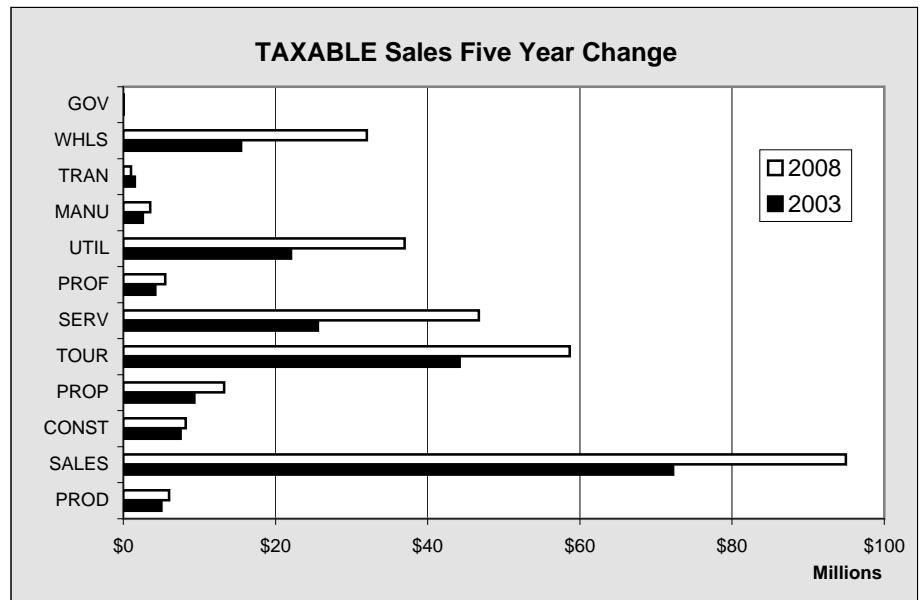

Chart 7.12

Other KPB Sales

Other KPB GROSS Sales by Line of Business by Quarter - 2008 - in \$					
	1st Quarter	2nd Quarter	3rd Quarter	4th Quarter	Total
Resource Production	22,133,605	33,080,374	45,784,936	58,517,767	159,516,682
Sales	32,556,411	51,980,833	59,083,336	43,051,046	186,671,626
Construction	25,278,709	31,838,817	51,316,980	40,948,878	149,383,384
Property	5,550,990	8,408,459	11,126,489	9,331,675	34,417,613
Tourism	2,945,041	21,073,270	41,298,197	3,959,159	69,275,667
Services	22,393,415	29,435,249	33,621,532	29,031,330	114,481,526
Professional	5,180,824	7,835,377	7,977,031	6,444,914	27,438,146
Utility	15,739,528	12,833,201	12,367,684	16,707,332	57,647,745
Manufacturing	27,926,865	64,537,243	68,693,298	28,724,769	189,882,175
Transporation & Warehousing	5,093,222	8,126,006	10,602,554	8,996,532	32,818,314
Wholesale	32,500,366	40,939,315	48,422,043	336,622,470	458,484,194
Government	303,976	16,321	145,292	72,149	537,738
TOTAL	197,602,952	310,104,465	390,439,372	582,408,021	1,480,554,810

Table 7.19

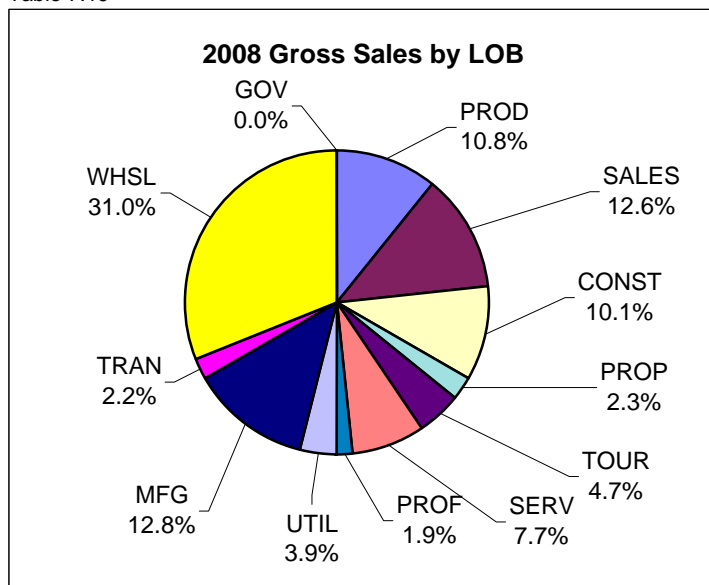

Chart 7.13

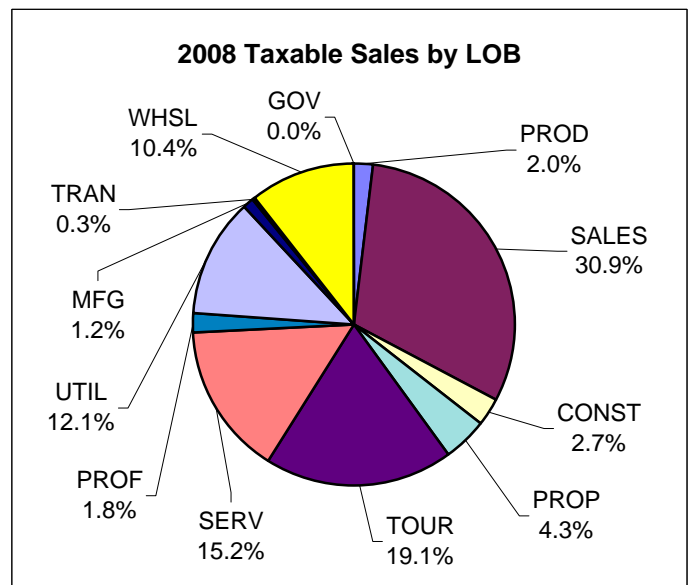

Chart 7.14

Other KPB TAXABLE Sales by Line of Business by Quarter - 2008 - in \$					
LOB	1st Quarter	2nd Quarter	3rd Quarter	4th Quarter	Total
Resource Production	912,669	1,939,300	1,578,775	1,580,458	6,011,202
Sales	15,978,538	26,163,244	32,285,768	20,507,787	94,935,337
Construction	1,495,920	1,999,973	2,692,592	2,006,375	8,194,860
Property	2,447,819	3,474,005	4,293,198	3,025,480	13,240,502
Tourism	2,636,558	18,479,839	34,464,374	3,092,473	58,673,244
Services	9,616,542	11,747,596	13,378,435	11,974,301	46,716,874
Professional	1,136,067	1,444,504	1,642,198	1,294,260	5,517,029
Utility	10,713,306	8,221,322	7,283,566	10,758,298	36,976,492
Manufacturing	407,765	940,643	1,586,836	610,022	3,545,266
Transporation & Warehousing	172,168	269,454	331,301	228,232	1,001,155
Wholesale	7,751,412	7,678,214	8,500,458	8,052,829	31,982,913
Government	15,266	8,551	16,273	13,660	53,750
TOTAL	53,284,030	82,366,645	108,053,774	63,144,175	306,848,624

Table 7.20

Other KPB Sales

Other KPB GROSS Sales by Line of Business by Quarter - 2007 - in \$					
LOB	1st Quarter	2nd Quarter	3rd Quarter	4th Quarter	Total
Resource Production	24,020,876	33,722,566	38,946,321	51,832,661	148,522,424
Sales	31,083,771	46,992,667	49,938,317	39,363,245	167,378,000
Construction	24,864,188	37,494,171	54,728,513	49,805,844	166,892,716
Property	6,001,714	8,171,623	9,730,259	10,198,601	34,102,197
Tourism	5,503,621	21,990,753	45,401,959	5,242,624	78,138,957
Services	17,094,489	21,589,435	24,183,117	22,797,887	85,664,928
Professional	4,900,707	5,367,801	6,515,407	6,610,318	23,394,233
Utility	16,970,630	12,163,388	12,726,668	13,724,445	55,585,131
Manufacturing	36,584,755	29,712,912	51,910,751	8,333,407	126,541,825
Transportation & Warehousing	4,658,253	6,698,060	8,671,902	6,021,352	26,049,567
Wholesale	25,345,813	29,204,686	35,865,559	295,052,191	385,468,249
Government	25,127	7,764	12,940	93,251	139,082
TOTAL	197,053,944	253,115,826	338,631,713	509,075,826	1,297,877,309

Table 7.21

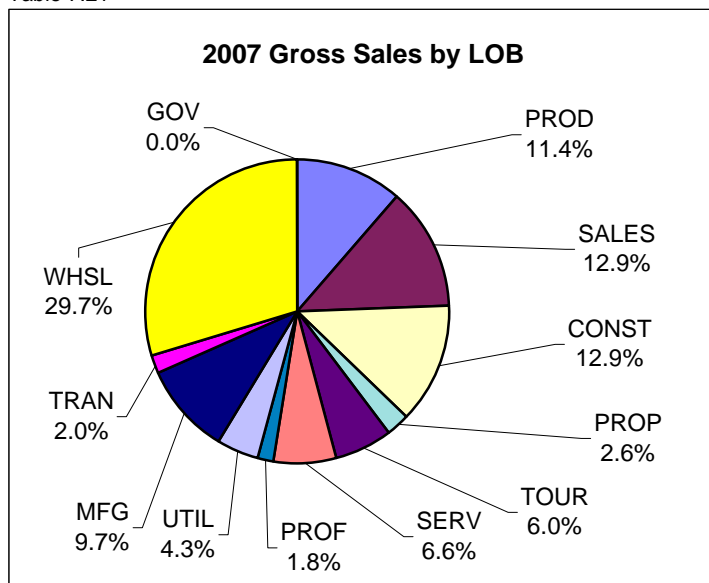

Chart 7.15

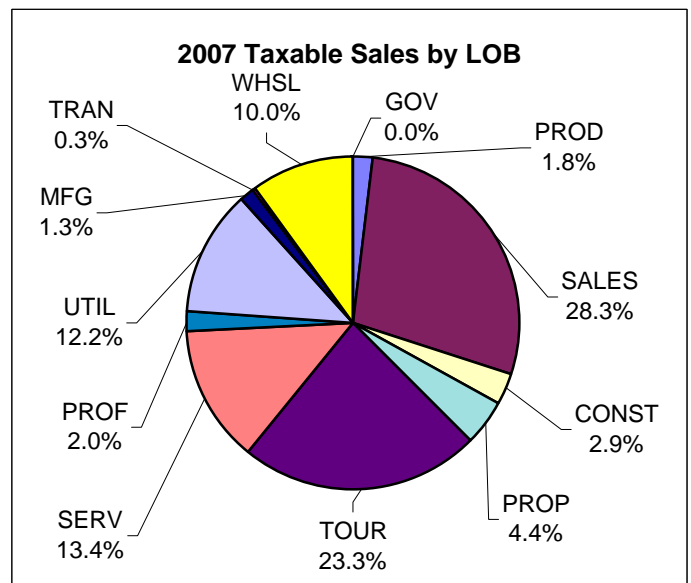

Chart 7.16

Other KPB TAXABLE Sales by Line of Business by Quarter - 2007 - in \$					
LOB	1st Quarter	2nd Quarter	3rd Quarter	4th Quarter	Total
Resource Production	831,139	1,764,037	1,387,047	1,262,053	5,244,276
Sales	13,703,348	22,280,866	26,073,089	18,095,709	80,153,012
Construction	1,380,642	2,023,788	2,577,681	2,186,430	8,168,541
Property	2,287,467	3,230,635	4,212,275	2,825,829	12,556,206
Tourism	3,937,072	19,442,729	38,176,410	4,473,486	66,029,697
Services	7,646,756	9,823,932	11,027,912	9,583,765	38,082,365
Professional	1,262,078	1,472,696	1,572,158	1,398,597	5,705,529
Utility	11,366,562	7,552,563	6,796,828	8,820,971	34,536,924
Manufacturing	405,938	1,036,940	1,463,674	786,465	3,693,017
Transportation & Warehousing	155,418	206,472	324,649	250,307	936,846
Wholesale	7,055,149	6,331,399	6,876,790	8,147,426	28,410,764
Government	12,918	3,500	4,600	5,790	26,808
TOTAL	50,044,487	75,169,557	100,493,113	57,836,828	283,543,985

Table 7.22

Other KPB Sales

Other KPB GROSS Sales by Line of Business by Quarter - 2006 - in \$					
LOB	1st Quarter	2nd Quarter	3rd Quarter	4th Quarter	Total
Resource Production	40,136,212	41,957,147	60,652,271	32,377,396	175,123,026
Sales	26,508,008	45,135,003	48,093,824	36,843,971	156,580,806
Construction	17,817,358	27,340,871	46,760,343	62,322,648	154,241,220
Property	5,259,580	7,716,904	8,956,250	7,176,819	29,109,553
Tourism	4,306,310	21,514,681	43,086,571	5,598,667	74,506,229
Services	14,306,132	17,396,627	19,221,244	19,160,532	70,084,535
Professional	4,316,631	4,661,169	5,516,835	6,655,343	21,149,978
Utility	14,204,879	10,777,719	10,142,989	14,131,249	49,256,836
Manufacturing	14,106,987	41,631,528	43,841,736	21,938,406	121,518,657
Transportation & Warehousing	6,124,411	11,159,723	11,866,058	8,774,423	37,924,615
Wholesale	25,363,123	32,318,210	38,053,327	263,634,332	359,368,992
Government	116,915	30,523	32,688	332,503	512,629
TOTAL	172,566,546	261,640,105	336,224,136	478,946,289	1,249,377,076

Table 7.23

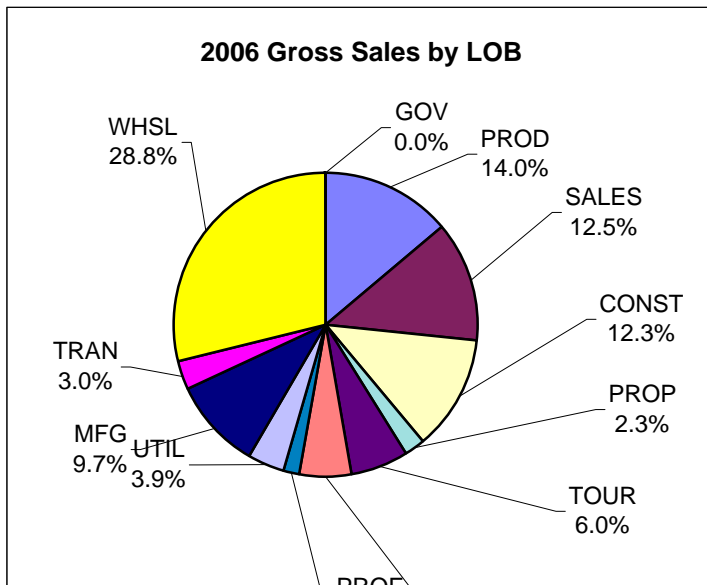

Chart 7.17

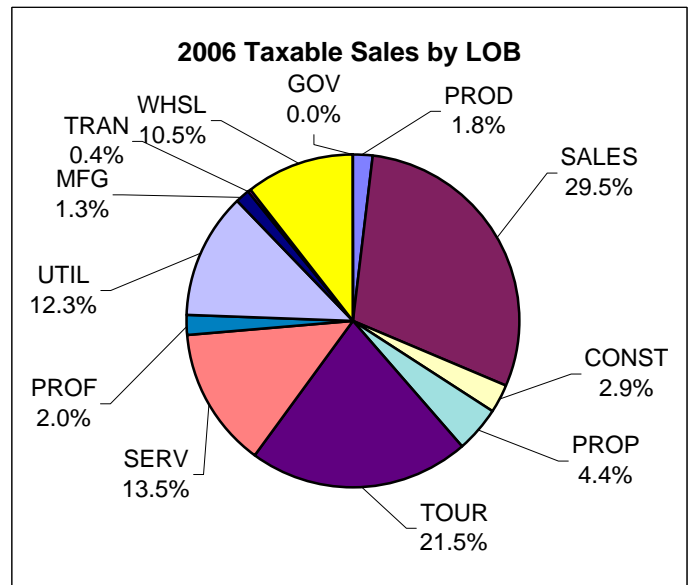

Chart 7.18

Other KPB TAXABLE Sales by Line of Business by Quarter - 2006 - in \$					
LOB	1st Quarter	2nd Quarter	3rd Quarter	4th Quarter	Total
Resource Production	802,513	1,578,756	1,182,198	1,065,297	4,628,764
Sales	13,259,849	21,001,208	24,274,092	16,881,665	75,416,814
Construction	1,206,598	1,949,022	2,286,957	1,935,789	7,378,366
Property	2,086,901	2,860,373	3,617,941	2,678,530	11,243,745
Tourism	3,860,547	16,514,092	29,965,900	4,534,785	54,875,324
Services	7,172,380	9,020,442	10,063,181	8,349,108	34,605,111
Professional	1,210,386	1,372,049	1,300,016	1,223,788	5,106,239
Utility	9,589,952	6,739,938	5,860,772	9,142,420	31,333,082
Manufacturing	383,815	864,966	1,374,752	601,350	3,224,883
Transportation & Warehousing	167,308	319,294	323,315	224,748	1,034,665
Wholesale	6,219,778	6,165,135	7,075,889	7,286,491	26,747,293
Government	1,500	3,279	3,024	7,500	15,303
TOTAL	45,961,527	68,388,554	87,328,037	53,931,471	255,609,589

Table 7.24

Other KPB Sales

Other KPB Annual Gross Sales by Quarter - in \$						
	1st Quarter	2nd Quarter	3rd Quarter	4th Quarter	Total	Annual Change
1994	108,045,292	168,026,112	227,742,774	160,338,704	664,152,882	
1995	129,319,512	176,942,172	232,992,009	155,265,007	694,518,700	4.6%
1996	118,786,765	164,578,524	200,339,231	146,554,575	630,259,095	-9.3%
1997	121,205,814	175,801,297	252,318,601	180,020,471	729,346,183	15.7%
1998	153,607,622	211,191,964	235,128,992	193,091,815	793,020,393	8.7%
1999	139,467,460	180,730,033	232,742,495	182,290,390	735,230,378	-7.3%
2000	126,664,981	183,977,517	225,474,396	172,187,791	708,304,685	-3.7%
2001	170,550,210	217,647,967	286,402,452	290,090,088	964,690,717	36.2%
2002	159,548,666	216,025,032	262,921,008	224,634,715	863,129,421	-10.5%
2003	154,468,221	208,425,856	284,006,188	215,378,758	862,279,023	-0.1%
2004	159,173,241	188,780,789	327,922,328	426,927,310	1,102,803,668	27.9%
2005	184,979,440	243,131,973	328,022,121	448,574,264	1,204,707,798	9.2%
2006	172,566,546	261,640,105	336,224,136	478,946,289	1,249,377,076	3.7%
2007	197,053,944	253,115,826	338,631,713	509,075,826	1,297,877,309	3.9%
2008	197,602,952	310,104,465	390,439,372	582,408,021	1,480,554,810	14.1%
2009	294,830,262	242,601,288			537,431,550	
Change	49.2%	-21.8%				

Table 7.25

Other KPB Annual Taxable Sales by Quarter - in \$						
	1st Quarter	2nd Quarter	3rd Quarter	4th Quarter	Total	Annual Change
1994	28,736,078	41,443,906	48,711,068	33,683,616	152,574,668	
1995	29,644,424	44,645,720	52,741,544	35,750,019	162,781,707	6.7%
1996	30,771,780	44,983,027	53,390,165	35,276,802	164,421,774	1.0%
1997	31,351,194	47,363,481	56,193,073	37,525,660	172,433,408	4.9%
1998	33,492,756	49,242,778	58,040,464	38,773,336	179,549,334	4.1%
1999	34,368,956	50,767,013	61,333,821	41,006,238	187,476,028	4.4%
2000	35,696,361	55,205,057	66,472,925	41,967,937	199,342,280	6.3%
2001	38,055,259	57,871,082	68,871,018	46,773,634	211,570,993	6.1%
2002	41,860,984	57,515,479	69,125,012	42,247,807	210,749,282	-0.4%
2003	38,386,873	58,301,294	69,993,550	43,042,009	209,723,726	-0.5%
2004	39,079,687	58,517,472	75,693,357	45,495,475	218,785,991	4.3%
2005	41,198,163	63,286,728	79,531,269	48,772,505	232,788,665	6.4%
2006	45,961,527	68,388,554	87,328,037	53,931,471	255,609,589	9.8%
2007	50,044,487	75,169,557	100,493,113	57,836,828	283,543,985	10.9%
2008	53,284,030	82,366,645	108,053,774	63,144,175	306,848,624	8.2%
2009	40,893,961	57,431,593			98,325,554	
Change	-23.3%	-30.3%				

Table 7.26

Other KPB Annual Non-Taxable Sales by Quarter - in \$						
	1st Quarter	2nd Quarter	3rd Quarter	4th Quarter	Total	Annual Change
1994	79,309,214	126,582,206	179,031,706	126,655,088	511,578,214	
1995	99,675,088	132,296,452	180,250,465	119,514,988	531,736,993	3.9%
1996	88,014,985	119,595,497	146,949,066	111,277,773	465,837,321	-12.4%
1997	89,854,620	128,437,816	196,125,528	142,494,811	556,912,775	19.6%
1998	120,114,866	161,949,186	177,088,528	154,318,479	613,471,059	10.2%
1999	105,098,504	129,963,020	171,408,674	141,284,152	547,754,350	-10.7%
2000	90,968,620	128,772,460	159,001,471	130,219,854	508,962,405	-7.1%
2001	132,494,951	159,776,885	217,531,434	243,316,454	753,119,724	48.0%
2002	117,687,682	158,509,553	193,795,996	182,386,908	652,380,139	-13.4%
2003	116,081,348	150,124,562	214,012,638	172,336,749	652,555,297	0.0%
2004	120,093,554	130,263,317	252,228,971	381,431,835	884,017,677	35.5%
2005	143,781,277	179,845,245	248,490,852	399,801,759	971,919,133	9.9%
2006	126,605,019	193,251,551	248,896,099	425,014,818	993,767,487	2.2%
2007	147,009,457	177,946,269	238,138,600	451,238,998	1,014,333,324	2.1%
2008	144,318,922	227,737,820	282,385,598	519,263,846	1,173,706,186	15.7%
2009	253,936,301	185,169,695				
Change	76.0%	-18.7%	18.6%	15.1%	15.7%	

Table 7.27

**DIRECTORY
OF LOCAL
OFFICIALS**

Local Officials Directory

Kenai Peninsula Borough officials of the various governing bodies are listed on the following pages.

Officials listed are those who held office at the time of printing the report. Annual elections for public officials are held each October. For information regarding current public officials, check the appropriate website.

Kenai Peninsula Borough – <http://www.borough.kenai.ak.us/>

Kenai Peninsula Borough School District – <http://www.kpbsd.k12.ak.us/>

City of Homer – <http://www.ci.homer.ak.us/>

City of Kenai – <http://www.ci.kenai.ak.us/>

City of Seldovia – <http://www.cityofseldovia.com/>

City of Seward – <http://www.cityofseward.net/>

City of Soldotna – <http://www.ci.soldotna.ak.us/>

Local Officials Directory

Kenai Peninsula Borough Mayors

Kenai Peninsula Borough

Mayor David R. Carey 144 North Binkley
Soldotna, AK 99669
907-262-4441

City of Homer

Mayor Jim Hornady 491 East Pioneer Ave.
Homer, AK 99603
907-235-8121

City of Kachemak

Mayor Philemon Morris PO Box 958
Homer, AK 99603
907-235-8897

City of Kenai

Mayor Pat Porter 210 Fidalgo Street, Suite 200
Kenai, AK 99611
907-283-7535

City of Seldovia

Mayor Keith Gain Drawer B
Seldovia, AK 99663
907-234-7643

City of Seward

Mayor Clark Corbridge PO Box 167
Seward, AK 99664
907-224-4046

City of Soldotna

Mayor Peter Micciche 177 North Birch
Soldotna, AK 99669
907-262-9107

Table 8.1

Local Officials Directory

Kenai Peninsula Borough Mayor & Assembly				
144 N. Binkley Soldotna, Alaska 99669 Phone 907-714-2160 Assembly/Clerk Fax: 907-714-2388 Assembly e-mail: assemblyclerk@borough.kenai.ak.us				
Office / District	Name / Address	Phone / Fax / E-Mail	Term Expires	Previously Elected
Borough Mayor	David R. Carey 144 N. Binkley St. Soldotna, AK 99669	714-2150 W dcarey@borough.kenai.ak.us	2011	
Assembly 1 Kalifornsky	Gary Knopp 50465 Patrick Drive Kenai, AK 99611	283-9494 H 283-9800 F pa12gary@hotmail.com	2009	2006
Assembly 2 Kenai	Hal Smalley 105 Linwood Lane Kenai, AK 99611	283-7469 H hvsmalley@yahoo.com	2011	
Assembly 3 Nikiski	Gary Superman P.O. Box 8425 Nikiski, AK 99635	776-8448 H 776-8098 F 252-5264 W gsuperman@gci.net	2010	1989, 2001, 2004
Assembly 4 Soldotna	Pete Sprague - Vice President 188 Farnsworth Blvd. Soldotna, AK 99669	262-4073 H 262-8615 F psprague@acsalaska.net	2010	1998, 2001, 2002, 2004
Assembly 5 - Sterling / Funny River	Charles "Charlie" Pierce Sterling, AK 99672	262-9811 H cpierce@gci.net	2011	
Assembly 6 East Peninsula	Ron Long P.O. Box 2464 Seward, AK 99664	224-7068 H 224-5707 F rlms@ptialaska.net	2009	2000, 2003, 2006
Assembly 7 Central	Paul Fischer P.O. Box 889 Kasilof, AK 99610	262-9269 H 262-4902 F akifischer@hotmail.com	2010	1998, 2001, 2002, 2004
Assembly 8 Homer	Bill Smith P.O. Box 150 Homer, AK 99603	235-8932 H bsmith@xyz.net	2011	
Assembly 9 South Peninsula	Milli Martin P.O. Box 2652 Homer, AK 99603	235-6652 H 235-6652 F millimom@xyz.net	2009	2000, 2002, 2003, 2006
Acting Borough Clerk	Johni Blankenship 144 N. Binkley St. Soldotna, AK 99669	714-2160 262-8615 Fax assemblyclerk@borough.kenai.ak.us	N/A	

Table 8.2

Local Officials Directory

KENAI PENINSULA BOROUGH		
PLANNING COMMISSION MEMBERS		
2006		
Member	Contact Information	Term Expires
CHAIRMAN Philip Bryson P.O. Box 1041 Kenai, Alaska 99611-1041	283-4672 work 283-4428 home	Kenai City Term Expires July 31, 2010
VICE CHAIRMAN Blair Martin P.O. Box 1776 Soldotna, Alaska 99669-1776	283-5227 - home	Kalifornsky Beach Term Expires July 31, 2009
JoAnne Collins P.O. Box 341 Anchor Point, Alaska 99556-0962	235-8071 home	Anchor Point/Ninilchik Term Expires July 31, 2010
Linda Murphy P.O. Box 4124 Soldotna, Alaska 99669	262-1686 - home	Soldotna City Term Expires July 31, 2011
Dr. Rick Foster P.O. Box 3328 Homer, AK 99603-3328	235-9100 - home	Homer City Term Expires July 31, 2010
Mari Anne Gross 57485 Clover Avenue Homer, Alaska 99603	235-7330 - home	Southwest Borough Term Expires July 31, 2011
Sue McClure P.O. Box 3686 Seward, Alaska 99664-3686	907-224-6784 - home	Seward City Term Expires July 31, 2011
Harry Lockwood 37085 Rafie Court Soldotna, Alaska 99669	907-714-2200 c/o Planning Dept.	Ridgeway Term Expires July 31, 2010
James Isham P.O. Box 51 Soldotna, Alaska 99669-0051	262-9200 - home	Sterling Term Expires July 31, 2009
Brent Johnson 20773 Porcupine Lane Clam Gulch, Alaska 99568-9713	262-4763 - home	Kasilof/Clam Gulch Term Expires July 31, 2009
Paulette Bokenko-Carluccio P.O. Box 116 Seldovia, Alaska 99663-0278	37227575 - home	Seldovia City Term Expires July 31, 2009
Todd Petersen P.O. Box 651 Seward, Alaska 99664-0651	288-5050 - home 224-3350 - work 224-2388 - work fax	East Peninsula Term Expires July 31, 2010
Jason Taruiainen P.O. Box 7373 Nikiski, Alaska 99635-7373	776-3988 - home	Northwest Borough Term Expires July 31, 2011

Email address for the Planning Commission: planning@borough.kenai.ak.us

Fax Number for the Planning Commission: 907-714-2200

Table 8.3

Local Officials Directory

Kenai Peninsula Borough School District			
148 North Binkley Street Soldotna, AK 99669 907-262-5846			
<u>Board of Education</u>			
Sammie Crawford - President District 1	36615 Chinulna Drive Kenai, AK 99611	904-283-9271	Term Expires 2010
Sunni Hilts - Vice President District 9	P.O. Box 144 Seldovia AK 99663	907-234-7692	Term Expires 2010
Lynn Hohl - Treasurer District 6	P.O. Box 333 Seward, AK 99664	907-224-7300	Term Expires 2010
Gregory Gabriel, Jr. District 2	P.O. Box 3392 Soldotna, AK 99669	907-394-4604	Term Expires 2009
Joe Arness District 3	P.O. Box 1470 Kenai, AK 99611	907-776-8089	Term Expires 2011
Penny Vadla District 4	399 W. Riverview Avenue Soldotna, AK 99669	907-262-7249	Term Expires 2011
Marty Anderson District 5	P.O. Box 1388 Sterling, AK 99672	907-260-7500	Term Expires 2009
Bill Holt District 7	P.O. Box 794 Kasilof, AK 99610	907-283-7260	Term Expires 2011
Elizabeth Downing District 8	1247 Bay Avenue Homer, AK 99603	907-235-8555	Term Expires 2009
Student Representative Theresa Ramponi	Skyview High School 46188 Sterling Highway Soldotna, AK 99669	907-260-2300 c/o Skyview HS	Term Expires Sep-09

Table 8.4

<u>Administration</u>
Steve Atwater, Superintendent of Schools Dean Dusek, Assistant Superintendent Dave Jones, Assistant Superintendent of Instruction Melody Douglas, Chief Financial Officer

Table 8.5

Local Officials Directory

Kenai Peninsula Borough Department Directors	
Switchboard	(907) 262-4441 or (800) 478-4441
Assessing	Shane Horan
Capital Projects	Kevin Lyon
Clerk	Johni Blankenship
Finance	Craig Chapman
Legal	Colette Thompson
Maintenance	Loren Maggi
Resource Planning	Max Best
Road Maintenance	Doug Schoessler
Solid Waste	Jack Maryott

Table 8.6

Kenai Peninsula Borough Economic Development Agencies
<p>Kenai Peninsula Economic Development District - EDD 14790 Kenai Spur Highway, Ste. 106A Kenai, AK 99611 907-283-3335</p>
<p>Kenai Peninsula Tourism Marketing Council - KPTMC 35477 Kenai Spur Highway, Ste. 205 Soldotna AK 99669 907-262-5229</p>
<p>Kenai Peninsula Resource Conservation and Development, Inc. Trading Bay Plaza, Suite 150 PO Box 800, Kenai, AK 99611 907-283-7493</p>

Table 8.7

RECYCLE * RECYCLE * RECYCLE

Please recycle this document by removing the binding edge and depositing the mixed paper at a recycling collection station. The document can also be returned to the Borough Print Shop for edge removal and recycling.